



**ΕΘΝΙΚΟ ΜΕΤΣΟΒΙΟ ΠΟΛΥΤΕΧΝΕΙΟ**  
ΣΧΟΛΗ ΗΛΕΚΤΡΟΛΟΓΩΝ ΜΗΧΑΝΙΚΩΝ ΚΑΙ ΜΗΧΑΝΙΚΩΝ ΥΠΟΛΟΓΙΣΤΩΝ  
ΤΟΜΕΑΣ ΤΕΧΝΟΛΟΓΙΑΣ ΠΛΗΡΟΦΟΡΙΚΗΣ ΚΑΙ ΥΠΟΛΟΓΙΣΤΩΝ  
ΕΡΓΑΣΤΗΡΙΟ ΛΟΓΙΚΗΣ ΚΑΙ ΕΠΙΣΤΗΜΗΣ ΥΠΟΛΟΓΙΣΜΩΝ (Co.Re.Lab.)

**Παίγνια Συμφόρησης: Στοχαστικές Επεκτάσεις και  
Τεχνικές Μείωσης του Τιμήματος της Αναρχίας**

ΔΙΔΑΚΤΟΡΙΚΗ ΔΙΑΤΡΙΒΗ

ΤΟΥ

**Αθανασίου Β. Λιανέα**

Αθήνα, Δεκέμβριος 2014





**ΕΘΝΙΚΟ ΜΕΤΣΟΒΙΟ ΠΟΛΥΤΕΧΝΕΙΟ**  
ΣΧΟΛΗ ΗΛΕΚΤΡΟΛΟΓΩΝ ΜΗΧΑΝΙΚΩΝ ΚΑΙ  
ΜΗΧΑΝΙΚΩΝ ΥΠΟΛΟΓΙΣΤΩΝ  
ΤΟΜΕΑΣ ΤΕΧΝΟΛΟΓΙΑΣ ΠΛΗΡΟΦΟΡΙΚΗΣ ΚΑΙ ΥΠΟΛΟΓΙΣΤΩΝ  
ΕΡΓΑΣΤΗΡΙΟ ΛΟΓΙΚΗΣ ΚΑΙ ΕΠΙΣΤΗΜΗΣ ΥΠΟΛΟΓΙΣΜΩΝ

## **Παίγνια Συμφόρησης: Στοχαστικές Επεκτάσεις και Τεχνικές Μείωσης του Τιμήματος της Αναρχίας**

ΔΙΔΑΚΤΟΡΙΚΗ ΔΙΑΤΡΙΒΗ

ΤΟΥ

**Αθανασίου Β. Λιανέα**

**Συμβουλευτική Επιτροπή:** Ευστάθιος Ζάχος (Επιβλέπων)  
Δημήτριος Φωτάκης  
Αριστείδης Παγουρτζής

Εγκρίθηκε από την επταμελή εξεταστική επιτροπή την 16<sup>η</sup> Δεκεμβρίου 2014.

.....  
Ευστάθιος Ζάχος  
Καθηγητής ΕΜΠ

.....  
Δημήτριος Φωτάκης  
Επ. Καθηγητής ΕΜΠ

.....  
Αριστείδης Παγουρτζής  
Επ. Καθηγητής ΕΜΠ

.....  
Αντώνιος Συμβώνης  
Καθηγητής ΕΜΠ

.....  
Σταύρος Κολλιόπουλος  
Αν. Καθηγητής ΕΚΠΑ

.....  
Ευάγγελος Μαρκάκης  
Επ. Καθηγητής ΟΠΑ

.....  
Βασίλειος Ζησιμόπουλος  
Καθηγητής ΕΚΠΑ

Αθήνα, Δεκέμβριος 2014.



.....  
**Αθανάσιος Β. Λιανέας**

Διδάκτωρ Ηλεκτρολόγος Μηχανικός και Μηχανικός Υπολογιστών Ε.Μ.Π.

© 2014, Αθανάσιος Β. Λιανέας (Athanasios V. Lianeas).

Με επιφύλαξη παντός δικαιώματος. All rights reserved.

Απαγορεύεται η αντιγραφή, αποθήκευση και διανομή της παρούσας εργασίας, εξ ολοκλήρου ή τμήματος αυτής, για εμπορικό σκοπό. Επιτρέπεται η ανατύπωση, αποθήκευση και διανομή για σκοπό μη κερδοσκοπικό, εκπαιδευτικής ή ερευνητικής φύσης.

Οι απόψεις και τα συμπεράσματα που περιέχονται σε αυτό το έγγραφο εκφράζουν τον συγγραφέα και δεν πρέπει να ερμηνευθεί ότι αντιπροσωπεύουν τις επίσημες θέσεις του Εθνικού Μετσόβιου Πολυτεχνείου.



## Περίληψη

Το αντικείμενο της διατριβής είναι η θεωρητική ανάλυση και γενίκευση μοντέλων παιγνίων συμφόρησης, με στόχο την μελέτη μεθόδων μείωσης του Τιμήματος της Αναρχίας και τη μελέτη στοχαστικών επεκτάσεων των παιγνίων συμφόρησης με παράλληλη έρευνα του κατά πόσο μπορούν αυτές να επηρεάσουν, είτε θετικά είτε αρνητικά, το Τιμήμα της Αναρχίας. Αρχικά, παρουσιάζονται βασικά στοιχεία της βιβλιογραφίας που έχουν άμεση σχέση με τα προβλήματα που μελετήθηκαν και στην συνέχεια ακολουθεί μια εκτεταμένη παρουσίαση των αποτελεσμάτων της εργασίας.

Παρουσιάζονται αποτελέσματα που αφορούν το παράδοξο του Braess σε παίγνια συμφόρησης όπου το κόστος κάθε παίκτη ισούται με το κόστος της πιο ακριβής ακμής (ακμή συμφόρησης) που χρησιμοποιεί και το κόστος του δικτύου ισούται με το κόστος της πιο ακριβής ακμής που χρησιμοποιείται. Μελετάται το πρόβλημα εύρεσης έστω και προσεγγιστικά καλύτερου υποδικτύου σε τέτοιου είδους παίγνια. Παρότι το αντίστοιχο πρόβλημα σε παίγνια με προσθετικά κόστη είχε κατηγοριοποιηθεί από πλευράς χρονικής πολυπλοκότητας για το εν λόγω πρόβλημα υπήρχαν κάποια αποτελέσματα μόνο για γενικεύσεις του και μάλιστα αρκετά πιο ασθενή από αυτά που παρουσιάζονται στην διατριβή. Για την πιο απλή εκδοχή του προβλήματος, μέσω μιας σύνθετης αναγωγής, αποδεικνύονται αποτελέσματα δυσκολίας στην προσέγγιση του καλύτερου υποδικτύου: είναι NP-δύσκολο το πρόβλημα εύρεσης έστω και  $O(n^{0.121})$  προσεγγιστικά καλού υποδικτύου (όπου  $n$  ο αριθμός κόμβων δικτύου). Παράλληλα καταδεικνύονται δύο υποκατηγορίες τέτοιων παιγνίων που δεν πάσχουν καθόλου από το παράδοξο ενώ δίνεται ένας προσεγγιστικός αλγόριθμος για περιπτώσεις δικτύων όπου η αναγωγή της απόδειξης της NP-δυσκολίας δεν μπορεί να εφαρμοστεί.

Παρουσιάζονται, επίσης, αποτελέσματα που έχουν να κάνουν με το παράδοξο του Braess σε παίγνια συμφόρησης με προσθετικά κόστη. Για τέτοιου είδους παίγνια επάνω σε Erdős-Rényi τυχαίους γράφους (ως υποκείμενα δίκτυα) έχει αποδειχτεί ότι με μεγάλη πιθανότητα εμφανίζεται το παράδοξο του Braess. Στην εργασία αυτή, το πρόβλημα εύρεσης καλύτερου υποδικτύου σε τέτοιου είδους παίγνια, διαισθητικά ανάγεται σε πρόβλημα εύρεσης καλύτερου υποδικτύου σε παίγνια όπου το υποκείμενο δίκτυο ανήκει στην πιο απλή οικογένεια υποδικτύων που θα μπορούσαν να πάσχουν από το παράδοξο, με την δυσκολία εύρεσης καλύτερου υποδικτύου σε τέτοια δίκτυα να παραμένει άγνωστη. Χρησιμοποιώντας ένα πολύ πρόσφατο αποτέλεσμα από τη θεωρία

πιθανοτήτων, δίνεται ένας πολυωνυμικός αλγόριθμος προσέγγισης του καλύτερου υποδικτύου σε τέτοια δίκτυα και ακολούθως, χρησιμοποιώντας τις επεκτατικές ιδιότητες των Erdős-Rényi γράφων, άγεται ένα προσεγγιστικά καλό υποδίκτυο του αρχικού δικτύου.

Σε λίγο διαφορετική κατεύθυνση, μελετώνται τα βασικά χαρακτηριστικά παιγνίων συμφοράς με αβεβαιότητα στις ακμές και παίκτες ευαίσθητους στο ρίσκο. Η κλασική μοντελοποίηση των παιγνίων συμφοράς αγνοεί την αβεβαιότητα στις ακμές που ενυπάρχει σε αρκετές περιπτώσεις της καθημερινότητας. Μοντελοποιώντας την αιτία της αβεβαιότητας στα κόστη των ακμών, στην εργασία, ορίζονται δύο "ορθογώνια" μοντέλα, ένα με στοχαστικούς παίκτες, όπου οι παίκτες συμμετέχουν ή όχι στο παίγνιο με δεδομένη πιθανότητα και άρα η πραγματική συμφορά για τις ακμές που επιλέγουν αποκτά τυχειότητα, και ένα με στοχαστικές ακμές, όπου οι ακμές δύνανται με κάποια πιθανότητα να έχουν "μη-κανονική" συμπεριφορά και να προσδίδουν μεγαλύτερη καθυστέρηση κατά την χρήση τους. Σε αυτά τα παίγνια γίνεται μελέτη ως προς την ύπαρξη σημείων ισορροπίας και συναρτήσεων δυναμικού ενώ μελετάται και η συμπεριφορά του τιμήματος της αναρχίας.

Ενοποιώντας τις δύο κατευθύνσεις, στην εργασία δίδεται ένας νέος τρόπος βελτίωσης του τιμήματος της αναρχίας σε παίγνια με αβεβαιότητα στις ακμές και παίκτες ευαίσθητους στο ρίσκο. Πιο συγκεκριμένα, δείχνεται ότι αν είναι δυνατή η προσθήκη επιπλέον αβεβαιότητας σε επιλεγμένες ακμές με τρόπον ώστε να μην αλλάζει το αναμενόμενο κόστος τους, τότε, λόγω της ευαισθησίας των παικτών στο ρίσκο, αυτές οι ακμές γίνονται λιγότερο προτιμητέες από τους παίκτες και συνεπώς το τίμημα της αναρχίας δύναται να βελτιωθεί λόγω της στροφής των παικτών προς ακμές που η βέλτιστη λύση θα επέλεγε για αυτούς. Το πρόβλημα που ορίζεται προς αυτή την κατεύθυνση μοιάζει με την περιορισμένη χρήση διοδίων σε δίκτυα και αποτελέσματα μπορούν να προκύψουν από εκεί. Στην εργασία δίνονται αποτελέσματα που προσπαθώντας να ακολουθήσουν τις Karush Kuhn Tucker συνθήκες βελτιστότητας δίνουν μια "οικονομικότερη" και καλύτερη διαχείριση της αβεβαιότητας και παρέχουν καλύτερη διαίσθηση για την προκύπτουσα βελτίωση του τιμήματος της αναρχίας.



## Abstract

The subject of this thesis is the theoretical analysis and generalization of congestion games models and it aims to provide a study on methods for reducing the Price of Anarchy and a study related to stochastic extensions of congestion games and in which extend the Price of Anarchy may be affected within them. First, the literature that relates mostly to the problems studied is presented and right after an extensive presentation of the results of the thesis follows.

The problem of finding or approximating the best subnetwork in bottleneck routing games is studied. Although the corresponding problem in additive costs congestion games is almost fully understood, for the problem studied here, the existing results hold for more general games and in fact are much weaker than the ones presented here. For the simplest version of this problem, via a complex reduction, an NP-hardness result for finding or approximating the best subnetwork of the underlying network is proved: it is NP-hard to approximate the best subnetwork by a factor less than  $O(n^{0.121})$  (where  $n$  is the number of nodes of the network). In the positive side it is proven that in some subclasses of these games the paradox does not appear at all and also it is given an approximation algorithm for some cases where the NP-hardness reductions cannot apply.

Results that have to do with Braess paradox in additive costs congestion games are presented. Prior to the work presented here, it has been proved that if the underlying network of a congestion game is a random Erdős-Rényi graph then with high probability it suffers from Braess Paradox. Here, it is proven that the problem of finding the best subnetwork in such random networks can be essentially reduced to the problem of finding the best subnetwork of a network belonging to the simplest class of graphs that may suffer from the paradox. Using a very recent result from the theory of probabilities, it is given a polynomial approximation algorithm for finding best subnetworks in such networks. Then, the expansion properties of Erdős-Rényi graphs are used and an approximately good subnetwork for the initial network is drawn.

By slightly changing direction, the basic properties of congestion games with uncertain delays and risk averse users are studied. The classic formulation of congestion games ignores uncertainty in delays that arises in many real life situations. Modeling the cause of uncertainty in delays, two orthogonal models are introduced, one with stochastic players, where each player participates in the game with a given probability and thus the actual delay on the edges that players choose gets uncertain, and another with stochastic edges where each edge, with a given probability, may “fail” and provide greater delay to the players using it. For the arising classes of games, the existence of pure Nash equilibrium and potentials and the behavior of the price of anarchy is studied.

Uniting the above directions, a new way for improving the price of anarchy in congestion games with uncertain delays and risk averse users is given. More specifically, it is shown that if one can insert uncertainty in the edges of the network in a way that the expected cost of those edges remains the same, then, because of the risk aversion of the players, these edges become less attractive for the players. Thus, the price of anarchy may improve as more players may turn to edges that the optimal solution would choose for them. The arising algorithmic problem relates to congestion games with restricted tolls and results can also be drawn from there. In this thesis Karush Kuhn Tucker conditions are closely followed and there are given results that give a better and “less cheap” use of extra uncertainty and provide better insight of the improvement in the price of anarchy.

*στους αλληλεπιδρώντες μου,  
σε αντίστοιχο ποσοστό*



## Ευχαριστίες

Ευχαριστώ τους καθηγητές μου: Στάθη Ζάχο για την πλήρως ενεπνευστική του διδασκαλία, εντός κι εκτός αμφιθεάτρου, καθ'όλη την διάρκεια των σπουδών μου, Δημήτρη Φωτάκη που με βοήθησε υπέρ το δέον χωρίς να του ζητήσω καν βοήθεια, Άρη Παγουριτζή που με ηρεμία και κατανόηση απαντούσε και απαντά στις ερωτήσεις φοιτητών (εμού συμπεριλαμβανομένου), Νίκο Παπαγεωργίου γιατί διπλασίασε την αγάπη μου για τα μαθηματικά και Δημήτρη Πετσετίδη γιατί με έμαθε να συγκεντρώνομαι στο ζητούμενο. Επίσης οφείλω ένα μεγάλο ευχαριστώ στα υπόλοιπα μέλη της επταμελούς επιτροπής εξέτασης του παρόντος διδακτορικού, Αντώνη Συμβώνη, Σταύρο Κολλιόπουλο, Βαγγέλη Μαρκάκη και Βασίλη Ζησιμόπουλο.

Ευχαριστώ τους +αδέλφους μου στο Εργαστήριο Λογικής και Επιστήμης Υπολογισμών (Co.Re.Lab.) της Σχολής Ηλεκτρολόγων Μηχανικών και Μηχανικών Υπολογιστών του Εθνικού Μετσόβιου Πολυτεχνείου, που βοήθησαν τόσο στην ακαδημαϊκή μου ανάπτυξη όσο και στην δημιουργία ιδανικού περιβάλλοντος στο εργαστήριο όλα αυτά τα χρόνια. Επιλέγοντας έναν αντιπρόσωπο για κάθε έτος (που όλοι στο εργαστήριο αγαπάμε όπου και αν τους βρίσκουμε), ευχαριστώ τους: Άρη Τέντε, Βαγγέλη Μπαμπά, Αντρέα Γκέμπελ, Αντρέα Γαλάνη, Θέμη Γουλεάκη, Χάρη Αγγελιδάκη, Μανώλη Ζαμπετάκη και Ναταλία Κωτσάνη. Επι τη ευκαιρία, προσθέτω ένα μεγάλο ευχαριστώ στα μέλη του πιο φοβερού study group του ΕΜΠ για όλους τους δρόμους... που βαδίσουμε μαζί.

Τέλος, ένα μεγάλο ευχαριστώ προς: τα πολυαγαπημένα μου ξαδέρφια Βασίλη, Γιωργία και Θανάση γιατί προσπαθώντας να τους μοιάσω έπρεπε να αναπτύξω πολλές πλευρές της προσωπικότητάς μου, τον αδερφό μου Γιώργο για τους ίδιους λόγους αλλά και γιατί μάλλον υπήρξε η αιτία να ανοίξω από νωρίς τα βιβλία και του γονεΐς μου Βασίλη και Αναστασία για την πέρα από κάθε περιγραφή βοήθειά τους όλα τα 30,997+0,75 χρόνια της ζωής μου.

Θανάσης Λιανέας  
Αθήνα, Δεκέμβριος 2014



## Διάρθρωση της Διατριβής

Τα παίγνια συμφόρησης αποτελούν σημαντικό κομμάτι της (αλγοριθμικής) θεωρίας παιγνίων. Αφού συνοψίσουμε κάποια βασικά στοιχεία της βιβλιογραφίας που μελετήθηκε, θα επικεντρωθούμε σε θέματα αυτής με τα οποία ασχοληθήκαμε ερευνητικά και θα παραθέσουμε τα ευρήματα των προσπαθειών μας, που έχουν να κάνουν με το παράδοξο του Braess, αλλά και με τη συμπεριφορά δύο γενικεύσεων παιγνίων συμφόρησης που προσπαθούν να προσομοιάσουν καλύτερα κάποιες πραγματικές καταστάσεις της ζωής.

Στο πρώτο κεφάλαιο συγκεντρώνουμε όλη την βιβλιογραφία που σχετίζεται με τα παίγνια συμφόρησης και την ερευνητική μας δουλειά και παρουσιάζουμε τις τεχνικές που προσπαθούν να μειώσουν την υποβάθμιση του δικτύου που προκαλεί η εγωιστική συμπεριφορά των παικτών.

Στο δεύτερο κεφάλαιο παρουσιάζουμε διαισθητικά την συνεισφορά μας ενώ στο τρίτο κεφάλαιο δίνουμε γενικούς ορισμούς που θα χρησιμοποιήσουμε στην παρουσίαση της δουλειάς μας.

Στο τέταρτο και πέμπτο κεφάλαιο θα εστιάσουμε στο παράδοξο του Braess, η εξάλειψη του οποίου αποτελεί τον πιο σίγουρο και άμεσο τρόπο για την μείωση της υποβάθμισης του δικτύου. Θα παρουσιάσουμε τεχνικά την δική μας συνεισφορά στο πεδίο αυτό με αποτελέσματα που έχουν να κάνουν 1) με την εξάλειψη του παραδόξου σε τυχαίας φύσης δίκτυα που αποδεδειγμένα πάσχουν από το παράδοξο όταν τα κόστη είναι προσθετικά και 2) με την δυσκολία εντοπισμού του παραδόξου και αποδοτικής εύρεσης έστω και προσεγγιστικά καλού υποδικτύου σε παίγνια όπου τα κόστη των μονοπατιών ισούνται με το βάρος της βαρύτερης τους ακμής.

Στο έκτο κεφάλαιο, αφού ορίσουμε δύο γενικεύσεις των παιγνίων συμφόρησης που αφορούν παίκτες ευαίσθητους στην αβεβαιότητα, θα τις αναλύσουμε ως προς την ύπαρξη ισορροπιών και συναρτήσεων δυναμικού και θα μελετήσουμε την συμπεριφορά του τιμήματος της αναρχίας, τη μονάδα μέτρησης της υποβάθμισης του δικτύου.

Στο έβδομο κεφάλαιο, δείχνουμε πως μπορούμε, σε παίγνια με παίκτες ευαίσθητους στην αβεβαιότητα, να χρησιμοποιήσουμε την ευαισθησία των παικτών και προσθέτοντας αβεβαιότητα σε μέρος του δικτύου να βελτιώσουμε την συμπεριφορά του τιμήματος της αναρχίας.

Στο όγδοο και τελευταίο κεφάλαιο, εξάγουμε τελικά συμπεράσματα, και παραθέτουμε-καταδεικνύουμε ανοικτά προβλήματα.





## Εκτεταμένη περίληψη

Τα Παίγνια Συμφόρησης αποτελούν ένα από τα πιο εκτενώς μελετημένα πεδία της αλγοριθμικής θεωρίας παιγνίων. Παρόλαυτα, όπως αναμενόταν υπάρχουν ακόμη ανοιχτά προβλήματα στην περιοχή.

Η στοχοποίησή μας ήταν διττή, αν και τελικά και τα δύο μέρη της συνδέονται. Στη μια κατεύθυνση ασχοληθήκαμε με προβλήματα σχετιζόμενα με το παράδοξο του *Braess* σε παίγνια με προσθετικά κόστη αλλά και σε παίγνια με κόστη συγκέντρωσης, παίγνια δηλαδή που το κόστος των μονοπατιών ισούτε με το κόστος της πιο ακριβής ακμής στο μονοπάτι, και με τα δύο προβλήματα να βρίσκονται στο χώρο των προβλημάτων που σχετίζονται με τη μείωση του τιμήματος της αναρχίας

Στην άλλη κατεύθυνση ασχοληθήκαμε με το πρόβλημα γενίκευσης των παιγνίων συμφόρησης με τρόπον ώστε οι τυχαιότητα στις συναρτήσεις καθυστέρησης να λαμβάνεται υπόψιν, εστιάζοντας κατά βάση στην μοντελοποίηση της πηγής της αβεβαιότητας στις καθυστερήσεις των ακμών. Πέρα από τα αποτελέσματα για αυτό το μοντέλο, με έκπληξη διαπιστώσαμε ότι αυτή η μοντελοποίηση ρίχνει φως σε ένα νέο τρόπο μείωσης του τιμήματος της αναρχίας, αυτό είναι η εκμετάλλευση του φόβου των παικτών απέναντι στην αβεβαιότητα ώστε προσθέτωντας αβεβαιότητα σαν θόρυβο στους πόρους-ακμές του δικτύου να βελτιωθεί η απόδοσή του. Αν σκεφτούμε το τελευταίο γεγονός, οι δυο κατευθύνσεις της δουλειάς μας εννοποιούνται.

Παρακάτω περιληπτικά δίνουμε τη συνεισφορά μας σε κάθε ένα από τα προβλήματα που μελετήθηκαν ενώ στις σκόλουθες ενότητες μπαίνουμε σε περισσότερες λεπτομέρειες.

- Το παράδοξο του *Braess* στις διαφορετικές εκδόσεις των παιγνίων συμφόρησης με κόστη συγκέντρωσης δεν ήταν πλήρως κατανοημένο και εμείς καταφέραμε να καθαρίσουμε το πεδίο για την βασική εκδοχή αυτών των παιγνίων (υποενότητα 9.1 και κεφάλαιο 11).
- Τυχαία δίκτυα που έχουν μελετηθεί μέχρι σήμερα, με μεγάλη πιθανότητα πάσχουν από το παράδοξο του *Braess* όταν τα κόστη είναι προσθετικά. Καταφέραμε να δείξουμε ότι κατά μίνα έννοια, ο τρόπος για να αποδείξεις το παραπάνω γεγονός μπορεί να χρησιμοποιηθεί για την εξάλειψη του παραδόξου σε αυτά τα δίκτυα (υποενότητα 9.2 και κεφάλαιο 12).

- Τα στοχαστικά παίγνια συμφόρησης και ο φόβος απέναντι στο ρίσκο έχουν τραβήξει πολύ προσοχή τα τελευταία χρόνια. Με τη δουλειά στο κεφάλαιο 13 (συνεισφορά στην υποενότητα 2.3), προχωράμε ένα βήμα ακόμη στην κατανόηση αυτής της κλάσης παιγνίων.
- Σε συγκεκριμένες περιπτώσεις, οι στοχαστικές καθυστερήσεις μπορούν να βελτιώσουν τη συμπεριφορά του δικτύου (βλ. [71]). Στο κεφάλαιο 14 (συνεισφορά στην υποενότητα 9.4), δείχνουμε πως μπορούμε να εκμεταλλευτούμε τον φόβο των παικτών και να βελτιώσουμε την απόδοση του δικτύου.

### Παράδοξο του Μπραες σε Παίγνια με Κόστη Συγκέντρωσης

Ερευνούμε την προσεγγισιμότητα του προβλήματος σχεδιασμού υποδικτύων στην πιο απλή και φαινομενικά πιο εύκολα να προσεγγιστεί έκδοσή των παιγνίων με κόστη συγκέντρωσης (με ένα μόνο ζεύγος προέλευσης-προορισμού). Το κύριο αποτέλεσμα μας είναι ότι το πρόβλημα εύρεσης βέλτιστου υποδικτύου είναι δύσκολο να προσεγγιστεί μέσα σε εύλογους παράγοντες, ακόμη και αν έχουμε γραμμικές αυστηρά αύξουσες συναρτήσεις καθυστέρησης. Εξ όσων γνωρίζουμε, αυτή είναι η πρώτη δουλειά που ερευνά την επιπτώσεις του παράδοξου του Βραεος και την προσεγγισιμότητα του προβλήματος σχεδιασμού υποδικτύων για τη βασική έκδοση των παιγνίων με κόστη συγκέντρωσης. Για την πρωτότυπη εργασία δείτε [41]. Το σχήμα 9.1 συλλαμβάνει το μοντέλο στο οποίο τα αποτελέσματα αυτής της εργασίας ισχύουν.

Στην ενότητα 11.2, χρησιμοποιούμε τεχνικές παρόμοιες με εκείνες του [31, 27], και δείχνουμε ότι τα παίγνια συμφόρησης δεν πάσχουν από το παράδοξο του *Braess*, είτε, εάν το δίκτυο είναι σειριακό-παράλληλο, ή αν λάβουμε υπόψη μόνο υποδιαδρομής-βέλτιστες Ναση ροές (ορισμός στην ενότητα 11.1).

Στην αρνητική πλευρά, στην ενότητα 11.3 δείχνουμε με μια αναγωγή από το 2 *Directed Disjoint path* πρόβλημα ότι ακόμη και για γραμμικές συναρτήσεις, είναι *NP* δύσκολο να αναγνωρίσουμε το παράδοξο (λήμμα 11.1). Στην πραγματικότητα, η αναγωγή δείχνει ότι είναι *NP* δύσκολο να γίνει διάκριση μεταξύ *paradox ridden* περιπτώσεων (περιπτώσεις χωρίς κάθολου παράδοξο) και περιπτώσεων χωρίς παράδοξο, και κατά συνέπεια, είναι *NP* δύσκολο να προσεγγίσουν το πρόβλημα σχεδιασμού δικτύου εντός παράγοντος μικρότερου του  $4/3$ .

Στην ενότητα 11.4, εφαρμόζουμε ουσιαστικά την ίδια αναγωγή, αλλά με έναν επαναλαμβανόμενο τρόπο, και αποδεινύουμε ένα πολύ ισχυρότερο αποτέλεσμα η προσεγγισιμότητας. Ειδικότερα, μπορούμε αν υποθέσουμε την ύπαρξη ενός *gap*, η οποία μας βεβαιώνει ότι η εύρεση του καλύτερου υποδι-

κτύου είναι μη προσεγγίσιμος μέσα σε ένα παράγοντα μικρότερο από  $\gamma$ , με κατασκευή παρόμοια με αυτή του λήμματος 11.1 αλλά με μερικές ακμές αντικαταστημένες από αντίγραφα του δικτύου που δίνει το συγκεκριμένο *gap*, να ενισχύσουμε το *inapproximability gap* με συντελεστή  $4/3$ , αυξάνοντας παράλληλα βέβαια το μέγεθος του δικτύου περίπου κατά έναν παράγοντα 8 (λήμμα 11.4). Ως εκ τούτου, ξεκινώντας από το *gap*  $4/3$  που δίνεται από το λήμμα 11.1, και αναδρομικά εφαρμόζοντας αυτή της κατασκευή ένα λογαριθμικό αριθμό φορών, δείχνουμε ότι είναι *NP* δύσκολο να προσεγγίσουμε το πρόβλημα σχεδιασμού δικτύου για παίγνια με γραμμικές συναρτήσεις καθυστέρησης μέσα σε έναν παράγοντα  $O(n^{0.121-\epsilon})$ , για οποιαδήποτε σταθερά  $\epsilon > 0$ . Ένα ενδιαφέρον τεχνικό σημείο είναι καταφέρνουμε να δείξουμε αυτό το *inapproximability* αποτέλεσμα, ακόμα κι αν δεν ξέρουμε πώς να υπολογίσουμε την χειρότερη ισορροπία στο υποδίκτυο. Η αναγωγή μας χρησιμοποιεί την συγκεκριμένη δομή του υποδικτύου για τον εντοπισμό καλής προσέγγισης για το καλύτερο υποδίκτυο. Εξ όσων γνωρίζουμε, αυτή είναι η πρώτη φορά που μια παρόμοια αναδρομική κατασκευή χρησιμοποιήθηκε για να μεγαλώσει το όριο μη προσεγγισιμότητας του προβλήματος σχεδιασμού δικτύων αλλά και για οποιοδήποτε άλλο πρόβλημα βελτιστοποίησης που σχετίζονται με την εγωιστική δρομολόγηση.

Στο τμήμα 11.5, θεωρούμε συναρτήσεις καθυστέρησης που πληρούν την προϋπόθεση *Lipschitz* και παρουσιάζουμε έναν αλγόριθμο για την εύρεση ένα υποδικτύου που είναι σχεδόν βέλτιστο όσον αφορά το κόστος στην χειρότερη Nash ισορροπία, όταν η χειρότερη ροή Nash σε το καλύτερο υποδίκτυο δρομολογεί μια μη αμελητέα ποσότητα της ροής στις ακμές που χρησιμοποιούνται. Ο αλγόριθμος βασίζεται στο *Sparcification* λήμμα του *Althofer* ([5]), και από την πρόσφατη εφαρμογή στο [42]. Για οποιαδήποτε σταθερά  $\epsilon > 0$ , ο αλγόριθμος υπολογίζει ένα υποδίκτυο και μια  $\epsilon/2$  προσεγγιστική Nash ροή με κόστος το πολύ προσαυξημένο κατά  $O(\epsilon)$  σε σχέση με το κόστος στο βέλτιστο υποδίκτυο. Ο χρόνος τρεξίματος είναι περίπου  $P^{\text{poly}(\log m)}/\epsilon^2$ , και είναι *quasipolynomial*, όταν το πλήθος των μονοπατιών είναι *quasipolynomial*.

### Παράδοξο του Μπραες σε Παίγνια με Προσθετικά Κόστη

Εφορμώντας από τα [24, 25, 84] που αποδεικνύουν ότι οι τυχαίοι *Erdos – Renyi*  $G(n, p)$  γράφοι είναι επιρρεπείς στο παράδοξο, υιοθετούμε μια καθαρά αλγοριθμική προσέγγιση. Εστιάζουμε στην τάξη των αποκαλούμενων καλών στιγμιοτύπων, που είναι περιπτώσεις δικτύων με τις ιδιότητες που χρησιμοποιούνται από τα [24, 84] για να αποδειχθεί η με μεγάλη πιθανότητα εμφάνιση του Βραεος παράδοξου στα τυχαία αυτά δίκτυα. Στην πραγματικότητα, κάποιος μπορεί εύκολα να βεβαιωθεί ότι τα τυχαία στιγμιοτύπα στα [24, 84] είναι καλά στιγμιοτύπα με μεγάλη πιθανότητα. Αποδεικνύουμε ότι σε πολλές

ενδιαφέρουσες περιπτώσεις, μπορεί η προσέγγιση του καλύτερου υποδικτύου και της ισορροπίας αυτού να γίνει αποδοτικά εφικτή. Αυτό που μπορεί να είναι ακόμη πιο εκπληκτικό είναι ότι ο προσεγγιστικός μας αλγόριθμος βασίζεται στις επεκτατικές ιδιότητες των καλών στιγμιτύπων, δηλαδή στις ίδιες ιδιότητες που χρησιμοποιούνται στα [24, 84] για την απόδειξη της με μεγάλης πιθανότητας ύπαρξης του παραδόξου στα καλά στιγμιότυπα! Εξ όσων γνωρίζουμε, τα αποτελέσματά μας είναι τα πρώτα θεωρητικού χαρακτήρα που δείχνουν ότι το παράδοξο του *Braess* μπορεί να εξαλειφθεί αποτελεσματικά σε μια μεγάλη κατηγορία ενδιαφέρουσων περιπτώσεων. Για την πρωτότυπη εργασία δείτε το [41]. Το σχήμα 9.2 συλλαμβάνει το μοντέλο που θεωρείται σε αυτή την εργασία.

Τεχνικά, παρουσιάζουμε ουσιαστικά ένα προσεγγιστικό σχήμα. Για ένα καλό στιγμιότυπο και κάθε σταθερά  $\epsilon > 0$ , υπολογίζουμε μια ροή  $g$  που είναι μια  $\epsilon$  *Nash* ροή για το υποδίκτυο που αποτελείται από τις ακμές που χρησιμοποιούνται από αυτήν, και έχει κόστος  $L(g) \leq (1 + \epsilon)L + \epsilon$ , όπου  $L$  είναι το κόστος της ισορροπίας στο καλύτερο υποδίκτυο (Θεώρημα ). Η ροή  $g$  έχει με μεγάλη πιθανότητα αυτές τις ιδιότητες. Τα αποτελέσματα μας ισχύουν για οποιοδήποτε δίκτυο στην κατηγορία των καλών στιγμιτύπων. Αυτό, φυσικά, περιλαμβάνει τους  $G(n, p)$  γράφους με το  $p$  να είναι πάνω από το όριο συνεκτικότητας, αλλά επίσης μπορεί να περιλαμβάνει άλλους τύπους τυχαίων *expanders* (επεκτατών). Το ροοσεγγιστικό μας σχήμα τρέχει σε πολυωνυμικό χρόνο για την πιο ενδιαφέρουσα περίπτωση, που το δίκτυο είναι σχετικά αραιό και το ποσό συνολικής κυκλοφορίας  $r$  είναι  $O(\text{poly}(\ln \ln n))$ , όπου  $n$  είναι ο αριθμός των κορυφών. Συγκεκριμένα, ο χρόνος τρεξίματος είναι πολυωνυμικός αν το καλό δίκτυο έχει μέσο βαθμό  $O(\text{poly}(\ln n))$ , δηλαδή, αν  $pn = O(\text{poly}(\ln n))$ , για το τυχαίο  $G(n, p)$  δίκτυο και *quasipolynomial* για μέσους βαθμούς μέχρι  $o(n)$ . Όσον αφορά το συνολικό ποσό κυκλοφορίας, οι περισσότερες εργασίες εγωιστικής δρομολόγησης και επίλυσης προβλημάτων σχεδιασμού δικτύων με εγωιστικούς χρήστες υποθέτουν ότι  $r = 1$ , ή τουλάχιστον ότι το  $r$  δεν αυξάνει με το μέγεθος του δικτύου (βλ. π.χ., στο [76], και τις αναφορές εκεί). Έτσι πορούμε και προσεγγίζουμε σε πολυωνυμικό χρόνο, το καλύτερο υποδίκτυο για μια μεγάλη κατηγορία περιπτώσεων που, με μεγάλη πιθανότητα, περιλαμβάνουν εκθετικά πολλά  $s - t$  μονοπάτια και μονοπάτια μήκους  $\Theta(n)$ . Για τέτοιες περιπτώσεις, μια άμεση εφαρμογή του [[42], Θεώρημα 3] δίνει έναν αλγόριθμο εκθετικού χρόνου.

Η κεντρική ιδέα πίσω από την προσέγγισή μας, και η κύρια τεχνική μας συνεισφορά μας, είναι μια πολυωνυμικού χρόνου αναγωγή του προβλήματος σε ένα καλό στιγμιότυπο  $G$  σε πρόβλημα σε ένα απλουστευμένο δίκτυο  $G_0$ , το οποίο είναι ένα *layered* δίκτυο που προκύπτει αν κρατήσουμε από τον  $G$  μόνο τον  $s$ , τον  $t$  και τους τους άμεσους γείτονες τους, και συνδέσουμε όλους τους γείτονες του  $s$  και του  $t$  με μηδενικού κόστους ακμές. Πρώτα δείχνουμε ότι το

κόστος της ισορροπίας στο καλύτερο υποδίκτυο δεν αυξάνεται όταν θεωρούμε το απλοποιημένα  $G_0$  (λήμμα 12.2). Αν και αυτό μπορεί να ακούγεται λογικό, τονίζουμε ότι μικραίνοντας σε 0 το κόστος μιας ακμής μπορεί να προκαλέσουμε παράδοξο του Βραεσς (π.χ., ξεκινώντας από το δίκτυο στην Εικ. 8.2.α με  $d(v, w)(x) = 1$ , και τη μείωση στην  $d(v, w)(x) = 0$  είναι ένας άλλος τρόπος προκλήσης του παράδοξου). Η σημασία του απλοποιημένου δικτύου είναι ότι σε μεγάλο βαθμό απλοποιεί το πρόβλημα εύρεσης καλύτερου υποδικτύου, δεδομένου ότι μας επιτρέπει να επικεντρωθούμε στο φόρτωμα των ακμών των  $s$  και  $t$ . Σε έντονη αντίθεση, το αντίστοιχο υποδίκτυα σε [[84], Εικ. 36], [[25], Εν. 2.3 Εικ. 2], εκθέτουν το παράδοξο: εφαρμόζουν τα όρια του *Chernoff* για να δείξουν ότι υπάρχουν κατάλληλα μέρη του δικτύου στα οποία μπορεί να δρομολογηθεί ακόμη περισσότερη ροή μέσα από αυτά χωρίς να αυξηθεί το κόστος. Το παράδοξο έρχεται σαν αποτέλεσμα μιας διαισθητικά σωστής, έξυπνης παρατήρησης [49, 59]: η κοινή καθυστέρηση στην ισορροπία αυστηρά αυξάνεται με την συνολική ροή  $r$ . Προσεγγίζουμε το καλύτερο υποδίκτυο (θεώρημα 12.7) μέσω του απλοποιημένου δικτύου  $G_0$  χρησιμοποιώντας μια προσεγγιστική εκδοχή του θεώρηματος του Καραθεοδωρή (θεώρημα 12.6).

Το τελικό (και κρίσιμο) βήμα μας της προσέγγισης, είναι να ξεκινήσουμε με τη λύση στο απλοποιημένα δίκτυο, και να επεκταθούμε σε μια λύση στο αρχικό (καλό) στιγμιότυπο. Προς τούτο, δείχνουμε πώς μπορεί κάποιος να 'προσομοιώσει' τις μηδενικού κόστους ακμές στο ενδιάμεσο του δικτύου, με μονοπάτια πολύ χαμηλού κόστους στο αρχικό καλό στιγμιότυπο δικτύου. Διαισθητικά, αυτό λειτουργεί, λόγω των ιδιοτήτων επεκτατικότητας και των (τυχαίων) συναρτήσεων του καλού δικτύου  $G$ , για το ενδιάμεσο υποδίκτυο, που συνδέει γείτονες του  $s$  με τους γείτονες του  $t$ . Ουσιαστικά το εσωτερικό του  $G$  συμπεριφέρεται ως ένα πλήρες διμερές γράφημα με ακμές μηδενικού κόστους. Αυτό είναι επίσης το βασικό βήμα για την προσέγγιση των [24, 84], δείχνουν ότι το παράδοξο του Βραεσς εμφανίζεται σε καλή δίκτυα με υψηλή πιθανότητα (δείτε [[84], ενότητα 2]). Ως εκ τούτου, θα μπορούσε κανείς να υποστηρίξει ότι σε κάποιο βαθμό, ο λόγος για τον οποίο το παράδοξο του *Braess* υπάρχει σε καλά δίκτυα είναι ο ίδιος λόγος που το παράδοξο μπορεί αποτελεσματικά εκδιωχθεί. Αν και εννοιολογικά απλή, η πλήρης κατασκευή εμπλέκεται τεχνικά και απαιτεί πλήρη ενασχόληση με τις ροές στις ακμές των  $s$  και  $t$  και των γειτόνων τους. Η κατασκευή μας χρησιμοποιεί ένα προσεκτικό επιχείρημα ομαδοποίησης-ταιριάσματος, που με μεγάλη πιθανότητα δουλεύει καλά για καλά στιγμιότυπα, δείτε λήμματα 12.8 και 12.9.

Τονίζουμε ότι η αναγωγή η ίδια τρέχει σε πολυωνυμικό χρόνο. Το χρονοβόρο βήμα είναι η εύρεση μιας (προσεγγιστικής) λύσης στο απλοποιημένο δίκτυο. Δεδομένου ότι τα δίκτυα αυτά έχουν μόνο πολυωνυμικά πολλά (και πολύ σύντομα)  $s - t$  μονοπάτια, ξεφεύγουν από τα αποτελέσματα δυσκολίας του [78]. Το *approximability* του καλύτερου υποδικτύου για τα απλοποιη-

μένα δίκτυα είναι ένα ενδιαφέρον ανοιχτό πρόβλημα που απορρέει από την εργασία μας και που συζητάμε στην ενότητα 15.1.

Το αποτέλεσμα μας δείχνει ότι ένα πρόβλημα, που είναι *NP* δύσκολο να το προσεγγίσεις, μπορεί να προσεγγιστεί πολύ στενά σε τυχαία (και *randomlike*) δίκτυα. Αυτό μοιάζει με π.χ., το πρόβλημα της εξεύρεσης μια Χαμιλτονιανής διαδρομής σε *Erdos Renyi* γραφήματα, όπου και πάλι, η ύπαρξη και η κατασκευή δουλεύουν και πάλι ακριβώς πάνω από το όριο της συνδεσιμότητας, δείτε π.χ., [15]. Ωστόσο, δεν είναι όλα τα προβλήματα εύκολα αν κάποιος θεωρήσει τυχαίες τις εισόδους (π.χ., το *factoring* ή το πρόβλημα κρυμμένης κλίκα, που δεν είναι γνωστά σε πλήρες βάθος).

### Στοχαστικά Παίγνια Συμφόρησης

Εστιάζουμε την προσοχή μας στα ατομικό παίγνια συμφόρησης, και εισάγουμε δύο εκδοχές των στοχαστικών παιγνίων συμφόρησης, που εμπνέονται από τις κύριες πηγές αβεβαιότητας στις καθυστερήσεις των δικτύων μεταφορών και των τηλεπικοινωνιακών δικτύων. Ξεκινάμε από την παρατήρηση ότι η μεταβλητότητα στις καθυστερήσεις των ακμών προέρχεται είτε από τη μεταβλητότητα στην ζήτηση, και την επακόλουθη μεταβλητότητα στο φορτίο της ακμής, ή από το μεταβλητότητα της απόδοσης της ακμής. Αποσύνδεοντάς τες, εισάγουμε δυο ειδών στοχαστικά παίγνια συμφόρησης, που είναι τα *παίγνια συμφόρησης με στοχαστικούς παίκτες* και τα *παίγνια συμφόρησης με στοχαστικές σκμές*, που αντίστοιχα συλλαμβάνουν της περιπτώσεις αβεβαιότητας που αναφέρονται παραπάνω. Για το αρχικό έργο βλ. [6]. Το σχήμα 9.3 τοποθετεί τα μοντέλα μας στον χάρτη των παιγνίων συμφόρησης.

Τα παίγνια συμφόρησης με στοχαστικούς παίκτες στοχεύουν να πιάσουν τη μεταβλητότητα στην ζήτηση των ακμών. Συγκεκριμένα, κάθε παίκτης  $i$  συμμετέχει στο παιχνίδι, στην πραγματικότητα, διατρέχει το μονοπάτι του, ανεξάρτητα, με πιθανότητα  $p_i$ . Ως αποτέλεσμα, το συνολικό φορτίο του δικτύου και τα φορτία των ακμών και κατά συνέπεια τα κόστη τους είναι τυχαίες μεταβλητές. Από την άλλη πλευρά, τα παίγνια με στοχαστικές ακμές αποσκοπούν να πιάσουν την μεταβλητότητα της λειτουργικότητας του δικτύου. Τώρα, κάθε ακμή  $e$  μπορεί να λειτουργεί είτε στην 'τυπική' λειτουργία, όπου η καθυστέρηση δίνεται από μια συνάρτηση  $f_e(x)$ , ή στην 'ελλατωματική' λειτουργία, όπου η καθυστέρηση δίνεται από μια συνάρτηση  $g_e(x)$ , όπου  $g_e(x) \geq f_e(x)$  για κάθε  $x \geq 0$  (π.χ., μια ακμή λειτουργεί στην 'ελαττωματική' λειτουργία μετά από ένα μικρό ατύχημα ή μια αποτυχία σύνδεσης). Κάθε ακμή  $e$  συμπεριφέρεται στην 'τυπική' λειτουργία ανεξάρτητα με μια δεδομένη πιθανότητα  $p_e$ . Ως εκ τούτου, το φορτίο του δικτύου και τα φορτία των ακμών τώρα είναι ντετερμινιστικά, αλλά οι ακμές και οι καθυστερήσεις στα μονοπάτια είναι τυχαίες μεταβλητές. Και στις δύο παραλλαγές, υποθέτουμε ότι οι παίκτες να

έχουν κάποιο φόβο απέναντι στο ρίσκο που προσδίδουν οι στοχαστικές καθυστερήσεις. Συγκεκριμένα, κάθε παίκτης  $i$  έχει ένα (πιθανώς διαφορετικό) επίπεδο σιγουριάς  $\delta_i$ , και το ατομική του κόστος για ένα μονοπάτι  $q$  θεωρεί ότι είναι το  $\delta_i$ -χουαντιλε (γνωστός και ως *value – at – risk*) της κατανομής της καθυστέρησης του μονοπατιού  $q$ . Με απλά λόγια, το επιμέρους κόστος του παίκτη  $i$  είναι η ελάχιστη καθυστέρηση που μπορεί να νιώσει κατά μήκος του  $q$  με πιθανότητα τουλάχιστον  $\delta_i$ .

Στο εννοιολογικό επίπεδο, το μοντέλο των παιγνίων συμφόρησης με στοχαστικούς παίκτες είναι παρόμοιο με το μοντέλο με ενδογενή τυπικές αποκλίσεις των [67]. Στην πραγματικότητα, χρησιμοποιώντας τα όρια του *Chernoff*, μπορούμε να δείξουμε ότι για γραμμικές συναρτήσεις, εάν το αναμενόμενο φορτίο σε κάθε ακμή δεν είναι πολύ μικρό, τα  $\delta_i$  – *quantile* κόστη μπορούν να προσεγγισθούν με τις συναρτήσεις κόστους που χρησιμοποιούν στο [67]. Ωστόσο, θεωρούμε στοχαστικές απαιτήσεις, μια κατεύθυνση που προτείνεται και στο [67, Ενот. 7], και παίκτες που είναι ετερογενής όσον αφορά τη στάση τους απέναντι στο ρίσκο. Όσο για τα παίγνια συμφόρησης με στοχαστικές ακμές, το μοντέλο είναι εννοιολογικά παρόμοιο με το μοντέλο με εξωγενείς τυπικές αποκλίσεις των [67].

Στο τεχνικό μέρος, περιοριζόμαστε στη σημαντική ειδική περίπτωση δικτύων παραλλήλων ακμών με συμμετρικές στρατηγικές, και διερευνούμε πώς οι ιδιότητες των στοχαστικών παιγνίων συμφόρησης εξαρτώνται από το αν οι παίκτες έχουν τις ίδιες πιθανότητες συμμετοχής ή/και επιπέδου σιγουριάς ή όχι. Αρχικά, παρατηρούμε ότι τέτοια παιχνίδια επιδέχονται μια συνάρτηση δυναμικού και ένα αποδοτικό υπολογίσιμο *PNE*, αν οι παίκτες είναι ομοιογενείς, δηλαδή εάν έχουν το ίδιο επίπεδο σιγουριάς  $\delta$  και, στην περίπτωση με στοχαστικούς παίκτες, την ίδια συμμετοχή πιθανότητα  $p$  (θεωρήματα 13.1 και 13.8). Επίσης δείχνουμε ότι, αν οι παίκτες έχουν διαφορετικά επίπεδα σιγουριάς (και την ίδια πιθανότητα συμμετοχής, αν πρόκειται για στοχαστικούς παίκτες), τα στοχαστικά παίγνια συμφόρησης ανήκουν στην κατηγορία των παιγνίων συμφόρησης με παικτοεξαρτώμενες συναρτήσεις ([63]), και κατά συνέπεια η ύπαρξη *PNE* υπολογίζεται σε πολυωνυμικό χρόνο (πορίσματα 13.2 και 13.9). Στην αρνητική πλευρά, μπορούμε να αποδείξουμε ότι τέτοια παίγνια δεν δέχονται συνάρτηση δυναμικού (θεωρήματα 13.3 και 13.10). Για παίγνια συμφόρησης με στοχαστικούς παίκτες που έχουν το ίδιο επίπεδο σιγουριάς και διαφορετικές πιθανότητες συμμετοχής, ποδεικνύουμε ότι επιδέχονται μια λεξικογραφική συνάρτηση δυναμικού (θεώρημα 13.5), και έτσι και μια *PNE*, και επίσης ότι μια *PNE* μπορεί να υπολογιστεί από ένα απλό άπληστο αλγόριθμο (θεώρημα 13.4), όπου οι παίκτες διαδοχικά διαλέγουν την καλύτερη στρατηγική ανταπόκρισης σε μη-φθίνουσα σειρά πιθανοτήτων συμμετοχής, λαμβάνοντας υπόψη τις στρατηγικές των παικτών που προηγούνται στη σειρά. Όσο για την υποβάθμιση του δικτύου στην *PNE*, εστιάζοντας σε

δίκτυα παραλλήλων ακμών με αφινικές συναρτήσεις, αποδεικνύουμε ότι το κόστος της αναρχίας (PoA) είναι  $\Theta(n)$ , όπου  $n$  είναι ο αριθμός των παικτών, στην περίπτωση των στοχαστικών παικτών (θεωρήματα 14.3 και 13.7), και μπορεί να είναι μη φραγμένη, στην περίπτωση των στοχαστικών ακμών (θεώρημα 13.11).

### **Βελτιώνοντας την Απόδοση του Δικτύου Εκμεταλλευόμενοι τον Φόβο των Παικτών**

Με κίνητρο τα αποτελέσματα του [71], θεωρούμε (μη ατομικά) παίγνια συμφοράς με παίκτες ευαίσθητους στο ρίσκο και διερευνούμε πώς μπορεί κάποιος να εκμεταλλευτεί την αποστροφή των παικτών στον κίνδυνο ώστε να μεταβάλλει το αντιλαμβανόμενο από τους παίκτες κόστος έτσι ώστε το (αναμενόμενο) PoA για τις πραγματικές συναρτήσεις κόστους να βελτιώνεται σημαντικά. Εξ όσων γνωρίζουμε, αυτή είναι η πρώτη φορά που η αποστροφή απέναντι στο ρίσκο προτείνεται ως ‘θεραπεία’ στην υποβάθμιση του δικτύου λόγω της εγωιστική συμπεριφοράς των παικτών.

Αφειρηία μας είναι ότι σε ορισμένες πρακτικές εφαρμογές, μπορεί να εισάγουμε προσεκτικά εξωγενή διακύμανση στις καθυστερήσεις των ακμών έτσι ώστε η αναμενόμενη καθυστέρηση να μην αλλάζει, αλλά το κόστος που υπολογίζουν οι παίκτες λόγω του φόβου τους απέναντι στο ρίσκο να αλλάζει. Για παράδειγμα, σε ένα συγκοινωνιακό δίκτυο, αυτό μπορεί να γίνει αυξάνοντας ή μειώνοντας τυχαία το ποσοστό του χρόνου που διατίθεται για το πράσινο φανάρι ή ανοίγοντας ή κλείνοντας μια βοηθητική λωρίδα κυκλοφορίας. Σε ένα δίκτυο τηλεπικοινωνιών, μπορούμε με τυχαίο τρόπο να αυξάνουμε ή να μειώνουμε την ικανότητα των συνδέσεων που διατίθενται ή να αλλάζουμε την προτεραιότητα μεταξύ τους. Έτσι, υποθέτουμε ότι για κάθε ακμή  $e$ , μπορούμε να αυξήσουμε (κατά ένα μικρό πολλαπλασιαστικό συντελεστή) την καθυστέρηση της  $e$  με κάποια θετική πιθανότητα  $p_e$  και να την μειώσουμε με κάποια θετική πιθανότητα  $q_e$ , όπου τα  $p_e$  και  $q_e$  είναι συνήθως μικρές, έτσι ώστε η αναμενόμενη καθυστέρηση στην  $e$  να παραμένει  $d_e(x)$ . Από την άλλη πλευρά, η διακύμανση της καθυστέρησης που εισάγαμε με αυτές τις τυχαίες αλλαγές αυξάνει το θεωρούμενο από τους παίκτες κόστος. Ως εκ τούτου, προσαρμόζοντας προσεκτικά το αντιληπτό κόστος από τους παίκτες, μπορούμε να ελέγξουμε την συμφοράση του δικτύου, με έναν τρόπο που είναι εννοιολογικά παρόμοιος με εκείνο των φόρων ή των διοδίων, και να βελτιώσουμε το PoA μέσα από έναν εκλεπτισμένο και εύκολο να εφαρμοστεί μηχανισμό ο οποίος εκμεταλλεύεται την αποστροφή των παικτών στο ρίσκο.

Πιο συγκεκριμένα, υποθέτουμε ότι όλοι οι παίκτες έχουν ομοιογενή συμπεριφορά απέναντι στον κίνδυνο και ότι οι τυχαίες αλλαγές στο αντιληπτό κόστος των παικτών είναι ένας τον πολλαπλασιαστικός συντελεστή (συνήθως μικρός) του κόστους της ακμής. Στην πραγματικότητα, μπορούμε να υπο-



θέσουμε ότι η αντιληπτή συνάρτηση καθυστέρησης κάθε ακμής  $e$  μπορεί να αλλάξει από  $d_e(x)$  σε  $(1 + \gamma_e)d_e(x)$ , όπου το  $\gamma_e > 0$  μπορεί να εξαρτάται από την ακμή, τον τύπο και την πιθανότητα τυχαίων αλλαγών, τη στάση των παικτών απέναντι στο ρίσκο, το ακριβή τύπος του κόστους των παικτών, και το σημαντικότερο, από το εκάστοτε μοντέλο. Παρά το γεγονός ότι συζητούμε εν συντομία, στην ενότητα 14.1 πώς καθορίζεται το  $\gamma_e$  και παρέχουμε και μερικά παραδείγματα, για διατήρηση της απλότητας και της γενικότητας, σκόπιμα αποφεύγουμε να μπούμε σε λεπτομέρειες για το πως υπολογίζονται τα  $\gamma_e$ 's. Αντίθετα, εμείς απλά θεωρούμε ένα δεδομένο άνω όριο για την μεγαλύτερη τιμή του  $\gamma$  στις συναρτήσεις καθυστέρησης και αναφεόμαστε στο αντίστοιχο παίγνιο συμφοράς ως  $\gamma - \text{modifiable}$  παίγνιο (ή στιγμυότυπο), κατανοώντας ότι σε κάθε περίπτωση το  $\gamma$  μπορεί να καθοριστεί λαμβάνοντας υπόψη όλους τους παράγοντες που αναφέρονται παραπάνω. Με αυτούς τους ορισμούς, μια ροή (και συγκεκριμένα, η βέλτιστη ροή, η οποία ελαχιστοποιεί το συνολικό αναμενόμενο πραγματικό κόστος των παικτών) είναι  $\gamma - \text{enforceable}$  (ή απλά, *enforceable*) εαν πρόκειται για μια ροή Nash στο παραλλαγμένο παίγνιο με την αντιληπτή συνάρτηση κόστους κάθε ακμής  $e$  να είναι ίση με  $(1 + \gamma_e)d_e(x)$ , για κάποια  $\gamma_e \in [0, \gamma]$ .

Από τεχνικής πλευράς, παρατηρούμε ότι η μέγιστη αναλογία του *marginal cost toll* προς την καθυστέρηση στην βέλτιστη λύση για μια ακμή δίνει ένα άνω όριο για την τιμή των  $\gamma$  που απαιτείται για να γίνει ισορροπία η βέλτιστη ροή του δικτύου (πρόταση 16). Αυτό καθιερώνει τη δυνατότητα εφαρμογής της προσέγγισής μας και τυποποιεί την σύνδεσή της με τα επιστρεφόμενα διόδια. Ωστόσο, εκτός από το γεγονός ότι χρησιμοποιούμε πολλαπλασιαστικές τροποποιήσεις, μια σημαντική διαφορά της προσέγγισής μας από από τα διόδια είναι ότι πάντα υποθέτουμε ένα άνω όριο  $\gamma$  για την αλλαγή της αντιληπτής από τους παίκτες συνάρτησης για κάθε ακμή, ενώ τα βέλτιστα διόδια μπορεί να γίνουν αυθαίρετα μεγάλα, π.χ., τόσο μεγάλο όσο η καθυστέρηση στην πιο αργό  $s - t$  μονοπάτι που χρησιμοποιείται από τη βέλτιστη ροή (βλ. π.χ., [35, Θεώρημα 4.1]).

Στη συνέχεια, για να αποδείξουμε την αποτελεσματικότητα της προσέγγισής μας, εστιάζουμε στην απλή και σημαντική ειδική περίπτωση των δικτύων παραλλήλων ακμών (ενότ. 14.2). Χαρακτηρίζουμε την κατηγορία των  $\gamma - \text{modifiable}$  παιγνίων συμφοράς σε δίκτυα παραλλήλων ακμών για τα οποία η βέλτιστη ροή είναι εφικτό να γίνει ροή ισορροπίας στο τροποποιημένο δίκτυο (θεώρημα 14.1). Με βάση αυτό το χαρακτηρισμό, παρουσιάζουμε μια αναδρομική διαδικασία που δεδομένου ενός  $\gamma - \text{modifiable}$  παιγνίου συμφοράς και της βέλτιστη ροής, υπολογίζει ένα σύνολο  $\gamma - \text{bounded}$  μεταβολών στις συναρτήσεις με κάτω από τις οποίες το PoA είναι σημαντικά λιγότερο από το PoA του αρχικού παιγνίου (λήμμα 7.2). Γενικεύοντας την προσέγγιση με *variational inequality* του [29], μπορούμε να αποδείξουμε ότι το PoA της

καλύτερης ροής που μπορεί να προκύψει είναι  $\max\{1, (1 - \beta_\gamma(\mathcal{D}))^{-1}\}$ , όπου  $\mathcal{D}$  είναι η κλάση των συναρτήσεων καθυστέρησης του παιγνίου και

$$\beta_\gamma(\mathcal{D}) = \sup_{d \in \mathcal{D}, x \geq y \geq 0} \frac{y(d(x) - d(y)) - \gamma(x - y)d(x)}{xd(x)}$$

είναι μια φυσική γενίκευση της ποσότητας  $\beta(\mathcal{D})$  του [29] (θεώρημα 7.3). Για παράδειγμα, από την ανάλυση μας συνεπάγεται ότι για γραμμικές καθυστερήσεις, το PoA της καλύτερης  $\gamma$ -enforceable ροής υπολογισμένης με τη δική μας προσέγγιση είναι το πολύ  $\max\{1, (1 - (1 - \gamma)^2/4)^{-1}\}$  (πόρισμα 7.5), που είναι σημαντικά λιγότερο από το  $4/3$ , ακόμα και για μικρές τιμές του  $\gamma$  (π.χ., είναι λιγότερο από  $6/5$  για  $\gamma = 0, 1$ ). Επίσης δείχνουμε ότι η PoA ανάλυση όσον αφορά την  $\gamma$  είναι σφιχτή (θεώρημα 14.7). Τέλος, δίνουμε μια διαδικασία που υπολογίζει ένα σύνολο  $\gamma$ -bounded μεταβολών των συναρτήσεων καθυστέρησης και την αντίστοιχη  $\gamma$ -enforceable ροή με τέτοιο PoA η οποία τρέχει σε χρόνο πολυωνυμικά σχετιζόμενο με το χρόνο που απαιτείται για τον υπολογισμό Nash ροών σε δίκτυα παραλλήλων ακμών (λήμμα 14.8). Ως εκ τούτου, δεδομένου οποιοδήποτε  $\gamma$ -modifiable παιγνίου σε δίκτυο παραλλήλων ακμών, μπορούμε αποτελεσματικά (για μια ευρεία κατηγορία συναρτήσεων) να υπολογίζουμε ένα παίγνιο με τις αντιληπτές συναρτήσεις αλλαγμένες το πολύ κατά ένα παράγοντα  $1 + \gamma$ , έτσι ώστε το PoA είναι το πολύ  $\max\{1, (1 - \beta_\gamma(\mathcal{D}))^{-1}\}$ .

Στην ενότητα 14.3 συζητάμε την συσχέτιση των  $\gamma$ -modifiable παιγνίων συμφόρησης με τα παίγνια συμφόρησης με περιορισμένα διόδια (ή φόρους) ([17]). Επισημαίνουμε τα αποτελέσματα του [17] που μπορούν να εφαρμοστούν στα  $\gamma$ -modifiable παίγνια συμφόρησης ενώ υποστηρίζουμε την κατασκευαστική και πιο περίπλοκη προσέγγισή μας καθώς μας δίνει καλύτερη εικόνα για το πρόβλημα της εξεύρεσης βέλτιστων  $\gamma$ -modifications και για την βελτίωση του τιμήματος της αναρχίας.

Στην ενότητα 14.4, συζητάμε πώς η προσέγγιση μπορεί να επεκταθεί σε πιο γενικά πλαίσια. Πρώτα, δίνουμε τη διαίσθηση του πώς παρόμοιες τεχνικές με αυτές για τα δίκτυα παράλληλων ακμών μπορούν να χρησιμοποιηθούν για την περίπτωση σειριακών-παράλληλων δικτύων. Δεδομένου ότι έχουμε ολοκληρώσει τις αποδείξεις πολύ πρόσφατα, επιλέξαμε να μην υπερλάβουμε αυτά τα αποτελέσματα στην παρούσα διατριβή. Αντ' αυτού, εξηγούμε την προσέγγιση που χρειάζεται να κάνουμε παρέχοντας τις κεντρικές ιδέες. Αμέσως μετά συζητάμε πώς μπορούμε να καταλήξουμε σε παρόμοια αποτελέσματα για την περίπτωση δικτύων παραλλήλων ακμών με ετερογενείς παίκτες και γενικότερους περιορισμούς σχετικά με την αβεβαιότητα που επιτρέπεται να προστεθεί στις ακμές. Σημειώστε εδώ ότι αυτή την περίπτωση δεν έχει λυθεί από κανένα από τα [51], [17] και [53], που ασχολούνται με παίγνια συμφόρησης με φραγμένα διόδια-φόρους.

# Περιεχόμενα

<b>I</b>	<b>Ελληνική Έκδοση</b>	<b>31</b>
<b>1</b>	<b>Εισαγωγή</b>	<b>33</b>
1.1	Παίγνια Συμφόρησης . . . . .	33
1.2	Επισκόπηση Βιβλιογραφίας . . . . .	36
1.3	Βελτιώνοντας το τίμημα της αναρχίας . . . . .	38
1.3.1	Φορολόγηση των ακμών . . . . .	38
1.3.2	Αποφυγή του παραδόξου του Μπραες . . . . .	41
1.4	Παίγνια με παίκτες ευαίσθητους στο ρίσκο . . . . .	45
<b>2</b>	<b>Συνεισφορά της Εργασίας</b>	<b>49</b>
2.1	Παράδοξο του Μπραες σε Παίγνια με Κόστη Συγκέντρωσης . . . . .	50
2.2	Παράδοξο του Μπραες σε Παίγνια με Προσθετικά Κόστη . . . . .	52
2.3	Στοχαστικά Παίγνια Συμφόρησης . . . . .	55
2.4	Βελτιώνοντας την Απόδοση του Δικτύου Εκμεταλλευόμενοι τον Φόβο των Παικτών . . . . .	57
<b>3</b>	<b>Προκαταρκτικές Έννοιες</b>	<b>61</b>
3.1	Γενικοί Όροι και Συμβάσεις . . . . .	61
3.2	Ορισμοί Παιγνίων Συμφόρησης . . . . .	61
3.3	Ισορροπίες . . . . .	63
3.4	Τίμημα της Αναρχίας . . . . .	64
<b>4</b>	<b>Παράδοξο του Μπραες σε Παίγνια με Κόστη Συγκέντρωσης</b>	<b>67</b>
4.1	Εξειδικευμένοι Ορισμοί και Γεγονότα . . . . .	68
4.2	Έννοιες Ισορροπίας και Τοπολογίες που δεν Πάσχουν από το Παράδοξο . . . . .	70
4.3	Η αναγνώριση <i>Paradox – Ridden</i> Περιπτώσεων είναι Δύσκολη . . . . .	71
4.4	Η Προσεγγισιμότητα του Καλύτερου Υποδικτύου είναι Δύσκολη . . . . .	76
4.5	Δίκτυα με Σχεδόν Πολυωνυμικά Μονοπάτια . . . . .	86

<b>5</b>	<b>Παράδοξο του Μπράες σε Τυχαίας Φύσης Δίκτυα με Προσθετικά Κόστη</b>	<b>91</b>
5.1	Ορισμοί που αφορούν το Συγκεκριμένο Πρόβλημα . . . . .	91
5.2	Το σχήμα Προσέγγισης και το Περίγραμμα της Ανάλυσης . .	95
5.3	Απλοποίηση του δικτύου . . . . .	96
5.4	Προσεγγίζοντας το Βέλτιστο Υποδίκτυο στα Απλοποιημένα Δίκτυα	100
5.5	Επεκτείνοντας τη Λύση στα Καλά Δίκτυα . . . . .	104
<b>6</b>	<b>Παίγνια Συμφόρησης με Παίκτες Ευαίσθητους στο Ρίσκο</b>	<b>113</b>
6.1	Εισάγοντας τα Μοντέλα . . . . .	114
6.2	Παίγνια Συμφόρησης με Στοχαστικούς Παίκτες . . . . .	114
6.2.1	Το μοντέλο . . . . .	114
6.2.2	Στοχαστικοί παίκτες σε δίκτυα παραλλήλων ακμών: Υ- παρξη και υπολογισμός <i>PNE</i> . . . . .	115
6.2.3	Τμήμα της Αναρχίας σε Παίγνια με Αφινικές Συναρτήσεις	120
6.3	Παίγνια Συμφόρησης με Στοχαστικές Ακμές . . . . .	123
6.3.1	Το Μοντέλο . . . . .	123
6.3.2	Στοχαστικές Ακμές σε Δίκτυο Παραλλήλων Ακμών: Υ- παρξη και υπολογισμός <i>PNE</i> . . . . .	123
6.3.3	Τμήμα της Αναρχίας . . . . .	125
<b>7</b>	<b>Χρησιμοποιώντας Τυχειότητα προς Όφελος του Συνόλου</b>	<b>127</b>
7.1	Εισάγοντας τα $\gamma$ – <i>modifiable</i> Παίγνια Συμφόρησης . . . . .	128
7.2	Πειράζοντας τα Παίγνια σε Δίκτυα Παραλλήλων Ακμών . . . .	130
7.3	Σύνδεση με Παίγνια με Περιορισμένους Φόρους . . . . .	137
7.4	Αλλάζοντας τα Παίγνια σε πιο Γενικά Δίκτυα . . . . .	138
<b>II</b>	<b>English Version</b>	<b>141</b>
<b>8</b>	<b>Introduction</b>	<b>143</b>
8.1	Congestion Games . . . . .	143
8.2	Bibliography Overview . . . . .	146
8.3	Reducing the Price of Anarchy . . . . .	148
8.3.1	Taxing the Edges of the Network . . . . .	148
8.3.2	Stackelberg Strategies . . . . .	151
8.3.3	Tackling the Braess's Paradox . . . . .	153
8.4	Stochastic Congestion Games . . . . .	157
<b>9</b>	<b>Contribution</b>	<b>159</b>
9.1	Braess's Paradox in Bottleneck Costs Games . . . . .	160
9.2	Braess's Paradox in Additive Costs Games . . . . .	162

9.3 Stochastic Congestion Games . . . . .	164
9.4 Improving Selfish Routing through Risk Aversion . . . . .	166
<b>10 Congestion Games Preliminaries</b>	<b>171</b>
10.1 General Notation and Conventions . . . . .	171
10.2 Congestion Games Definitions . . . . .	171
10.3 Equilibria . . . . .	173
10.4 Price of Anarchy and Price of Stability . . . . .	174
<b>11 On the Hardness of Network Design for Bottleneck Routing Games</b>	<b>177</b>
11.1 Problem-Specific Definitions and Facts . . . . .	178
11.2 Paradox-Free Network Topologies and Paradox-Free Nash Flows . . . . .	179
11.3 Recognizing Paradox-Ridden Instances is Hard . . . . .	181
11.4 Approximating the Best Subnetwork is Hard . . . . .	186
11.5 Networks with Quasipolynomially Many Paths . . . . .	196
<b>12 Resolving Braess's Paradox in Random Networks</b>	<b>201</b>
12.1 Problem-Specific Definitions . . . . .	201
12.2 The Approximation Scheme and Outline of the Analysis . . . . .	204
12.3 Network Simplification . . . . .	206
12.4 Approximating the Best Subnetwork of Simplified Networks . . . . .	210
12.5 Extending the Solution to the Good Network . . . . .	214
<b>13 Congestion Games with Risk Averse Players</b>	<b>223</b>
13.1 Introducing the Models . . . . .	223
13.2 Congestion Games with Stochastic Players . . . . .	224
13.2.1 The Model . . . . .	224
13.2.2 Stochastic Players on Parallel Links: Existence and Computation of PNE . . . . .	225
13.2.3 Price of Anarchy for Games with Affine Latencies . . . . .	230
13.3 Congestion Games with Stochastic Edges . . . . .	233
13.3.1 The Model . . . . .	233
13.3.2 Stochastic Edges on Parallel Links: Existence and Computation of PNE . . . . .	233
13.3.3 Price of Anarchy . . . . .	235
<b>14 Improving Selfish Routing through Risk Aversion</b>	<b>237</b>
14.1 Introducing $\gamma$ -modifiable CGs . . . . .	237
14.2 Modifying Routing Games in Parallel-Link Networks . . . . .	240
14.3 Connection to Routing Games with Restricted Tolls . . . . .	247

14.4 Modifying Routing Games in more General Settings . . . . .	248
<b>15 Discussion</b>	<b>251</b>
15.1 Braess' Paradox in Additive Costs Games . . . . .	251
15.2 Braess' Paradox in Bottleneck Costs Games . . . . .	253
15.3 Stochastic Congestion Games . . . . .	254
15.4 Abusing Uncertainty . . . . .	255
<b>Bibliography</b>	<b>257</b>
<b>List of Figures</b>	<b>265</b>

**Μέρος Ι**  
**Ελληνική Έκδοση**





# Κεφάλαιο 1

## Εισαγωγή

Τα παίγνια συμφόρησης παρέχουν ένα φυσικό μοντέλο για μη συνεργατική κατανομή πόρων σε μεγάλης κλίμακας δίκτυα επικοινωνιών και έχουν αποτελέσει αντικείμενο εντατικής έρευνας στην Αλγοριθμική Θεωρία Παιγνίων. Σε αυτό το κεφάλαιο, εμείς πρώτα θα δώσουμε μια μικρή εισαγωγή στο “χώρο” των παιγνίων συμφόρησης, στο εσωτερικό του οποίου όλες οι (κύριες, μελετημένες) διαφορετικές περιπτώσεις και γενικεύσεις των παιγνίων συμφόρησης (ΠΣ εν συντομία) βρίσκονται. Μια επισκόπηση της βιβλιογραφίας δίνεται αμέσως μετά με έμφαση στο μέρος της βιβλιογραφίας που σχετίζεται έντονα με την δική μας εργασία.

### 1.1 Παίγνια Συμφόρησης

Σε ένα παίγνιο συμφόρησης [73], ένα σύνολο πανομοιότυπων μη συνεργατικών παικτών, που ελέγχουν ίση ποσότητα φορτίου, ανταγωνίζονται πάνω από ένα πεπερασμένο σύνολο των πόρων. Όλοι οι παίκτες που χρησιμοποιούν ένα συγκεκριμένο πόρο, νιώθουν ένα κόστος (ή καθυστέρηση) που δίνεται από μια μη αρνητικές και μη-φθίνουσες συναρτήσεις του φορτίου του πόρου (ή συμφόρηση).

Κάθε παίκτης επιλέγει την στρατηγική, ένα υποσύνολο των πόρων, εγωιστικά προσπαθώντας να ελαχιστοποιήσει την ατομικό του κόστος. Η εστίαση στα ΠΣ είναι στα δικτυακά ΠΣ όπου υπάρχει ένα υποκείμενο δίκτυο και ο χώρος στρατηγικών του κάθε παίκτη αποτελείται από τα μονοπάτια από τον κόμβο προέλευσης προς τον κόμβο του προορισμού στο δίκτυο. Οι ακμές του δικτύου, που έρχονται μαζί με ένα κόστος λειτουργίας, είναι οι πόροι του δικτυακού ΠΣ. Τα ακόλουθα ισχύουν για γενικά ΠΣ, αν και το περισσότερα από το έργο στη βιβλιογραφία αλλά και στη δική μας εργασία ασχολείται με δικτυακά ΠΣ.

### Περιπτώσεις.

Πολλές διαφορετικές περιπτώσεις ΠΣ προκύπτουν αν αναλογιστεί διαφορετικές υποθέσεις για το χώρο στρατηγικών των παικτών, τους τύπους των παικτών ή των κοστών των στρατηγικών των παικτών. Πιο συγκεκριμένα, οι παίκτες μπορούν όλοι να έχουν τον ίδιο χώρο στρατηγικών, περίπτωση συμμετρικών παιγνίων, ή διαφορετικό χώρο στρατηγικών, ασύμμετρη περίπτωση παιγνίων. Επίσης, οι παίκτες μπορεί να είναι πεπερασμένοι και να μεταφέρουν ένα σημαντικό ποσό (μονάδα) φόρτου στο δίκτυο, και έτσι μπορεί να επηρεάσει το κόστος των πόρων, περίπτωση ατομικών παιγνίων, ή να είναι άπειροι και με αμελητέο (απειροελάχιστα μικρό) ποσό της ροής μέσω του δικτύου και κατά συνέπεια δεν μπορούν μονομερώς να επηρεάζουν τις συναρτήσεις των των πόρων, μη-ατομικά παίγνια. Επιπλέον, το κόστος του κάθε παίκτη μπορεί να είναι το άθροισμα του κόστους των πόρων για τη στρατηγική του παίκτη, ΠΣ προσθετικού κόστους, ή το κόστος της μέγιστης ακμής πόρου μεταξύ των πόρων στη στρατηγική του παίκτη, ΠΣ ακμής συμφόρησης κόστους. Το σχήμα 1.1 παρουσιάζει σχηματικά τα παραπάνω.

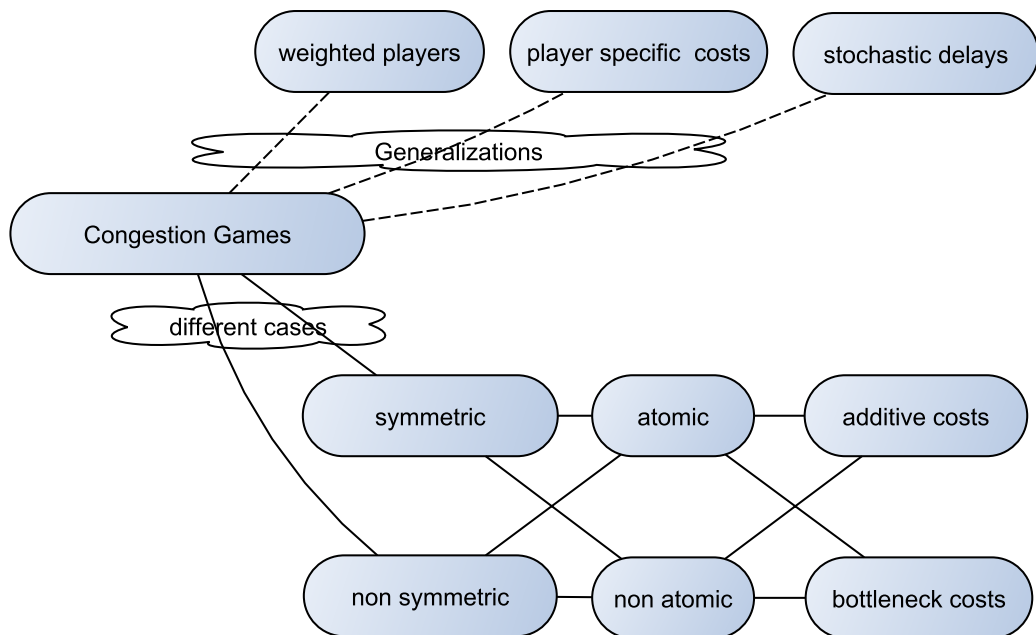

**Σχήμα 1.1:** Χάρτης (μικρός) δικτυακών παιγνίων συμφόρησης. Αναπαρίστανται στο πάνω μέρος οι επικρατούσες γενικεύσεις των ΠΣ. Το κάτω μέρος αναπαριστά τις διαφορετικές περιπτώσεις που προκύπτουν εξετάζοντας τις παραδοχές σχετικά με το χώρο στρατηγικών των παικτών, τους τύπους των παικτών και του κόστους των στρατηγικών των παικτών.

### Γενικεύσεις.

Τα ΠΣ μπορούν να γενικευθούν φυσικά σε παίγνια όπου οι παίκτες έχουν διαφορετικές απαιτήσεις (για την ατομική περίπτωση), που ονομάζονται βάρη, δηλαδή διαφορετικά ποσά της ροής μέσω του δικτύου (στα δικτυακά ΠΣ). Αυτά τα παιχνίδια ονομάζονται βεβαρυμένα ΠΣ. Μια άλλη φυσική γενίκευση υποθέτει ότι οι συναρτήσεις κόστους των πόρων εξαρτώνται από τον παίκτη, κάθε παίκτης δηλαδή αντιλαμβάνεται τη συνάρτηση κόστους (ενδεχομένως) διαφορετικά σε κάθε πόρο. Αυτά είναι ΠΣ με παικτοεξαρτώμενες συναρτήσεις κόστους. Τα τελευταία χρόνια, ΠΣ όπου οι παίκτες αποφασίζουν κάτω από αβεβαιότητα έχει αποκτήσει μεγάλο ενδιαφέρον. Μοντέλα ΠΣ με στοχαστικές καθυστερήσεις και παίκτες ευαίσθητους στο φόβο επεκτείνουν τα ΠΣ προκειμένου να συλλάβουν καλύτερα καταστάσεις της καθημερινότητας και να προβλέψει την ανθρώπινη συμπεριφορά.

Το Σχήμα 1.1 βοηθά.

### Απόδοση.

Σε ένα παίγνιο συμφόρησης, μια φυσική λύση έννοια είναι μια καθαρή *Nash* ισορροπία (ΠΝΕ), μια κατάσταση όπου κανένας παίκτης δεν μπορεί να μειώσει το κόστος με μονομερή αλλαγή της στρατηγικής του. Στο άλλο άκρο, ο διαχειριστής του δικτύου νοιάζεται για το δημόσιο όφελος και έχει ως στόχο να ελαχιστοποιήσει το συνολικό κόστος από όλους τους παίκτες. Δεδομένου ότι δεν χρειάζεται μια ισορροπία του *Nash* για τη βελτιστοποίηση του συνολικού κόστους, αναζητάτε η ποσοτικοποίηση της αναποτελεσματικότητας λόγω εγωιστική συμπεριφορά.

Το κόστος της αναρχίας εισήχθη στο [57] και έχει γίνει ένα ευρέως αποδεκτό μέτρο της υποβάθμιση της απόδοσης λόγω της εγωιστικής συμπεριφορά των παικτών. Το (καθαρό) κόστος της αναρχίας είναι ο λόγος χειρότερης περίπτωσης του κόστους σε μια (καθαρή) ισορροπία *Nash* προς το βέλτιστο συνολικό κόστος. Πολλές πρόσφατες συνεισφορές έδωσαν ισχυρά άνω και κάτω όρια ως προς την τιμή του κόστους της αναρχίας για τις διάφορες κατηγορίες ΠΣ. Η επικείμενη επισκόπηση της βιβλιογραφίας περιλαμβάνει επίσης αυτά τα αποτελέσματα.

Οι επικρατούσες ερωτήσεις στα ΠΣ μιας για τις διάφορες περιπτώσεις που περιγράφονται πιο πάνω (ή ακόμη και για υποπεριπτώσεις τους), έχουν να κάνουν με την ύπαρξη και τον υπολογισμό ισορροπιών, με το χρόνο της σύγκλισης των βέλτιστων ή απλά καλύτερων ακολουθιών απάντησης (δηλαδή τα μέτρα για να επιτύχουν μια ισορροπία που αρχίζει από μια αρχική διαμόρφωση και αφήνοντας τους παίκτες να κάνουν μια βέλτοση ή απλά καλύτερη απάντηση, ένας κάθε φορά), με την εύρεση ορίων για το τίμημα της αναρχίας και με τρόπους βελτίωσης των επιδόσεων του δικτύου (διόδια, στρα-

τηγικές *stackelberg*, αξιοποίηση παραδόξου Μπράες). Ετερο-αναφορές (μαζί με κάποιες λεπτομέρειες) που εξετάζουν αυτά τα ερωτήματα και τα κυριότερα αποτελέσματα της βιβλιογραφίας δίνονται στο υπόλοιπο του κεφαλαίου.

## 1.2 Επισκόπηση Βιβλιογραφίας

Στη συνέχεια βάζουμε μαζί πηγές βιβλιογραφίας που ασχολούνται με τις επικρατούσες ερωτήσεις στις διαφορετικές παραλλαγές του ΠΣ. Το μεγαλύτερο μέρος αυτής της βιβλιογραφίας αφορά κυρίως παίγνια με προσθετικά κόστη, αν και υπάρχει ένα μη αμελητέο μέρος σχετικά με παίγνια ακμών συμφόρησης. Για αποτελέσματα σχετικά με τη βελτίωση της απόδοσης του δικτύου ακολουθούν στην ενότητα 1.3 και για παιχνίδια με στοχαστική καθυστερήσεις βλέπε 1.4

### Προσθετικά κόστη.

Για αποτελέσματα σχετικά με την ύπαρξη *Nash* ισορροπίας, πρέπει κανείς να δει το [73] όπου χρησιμοποιείται η μέθοδος της συνάρτησης δυναμικού για την απόδειξη της ύπαρξης μιας καθαρής ισορροπίας *Nash* (ΠΝΕ) σε ΠΣ και το [66] όπου η ισοδυναμία των ΠΣ με παίγνια δυναμικού αποδεικνύεται.

Για αποτελέσματα στην πολυπλοκότητα της εξεύρεσης καθαρής ισορροπίας *Nash* βλέπε π.χ. [33], όπου η κλάση *PLS* αποδείχθηκε ότι συλλαμβάνει πλήρως τη δυσκολία της εξεύρεσης καθαρής *Nash* ισορροπίας στην γενική, συμμετρική ή ασύμμετρη περίπτωση ΠΣ, [30], όπου αποτελέσματα δυσκολίας για την ύπαρξη καθαρής ισορροπίας *Nash* (ΠΝΕ) σε σταθμισμένο παιχνίδι δίνεται και [3] όπου η δυσκολία για τον υπολογισμό και την ύπαρξη της ΠΝΕ σε παικτοεξαρτώμενων συναρτήσεων ΠΣ.

Για αποτελέσματα για το τιμήμα της αναρχίας σε μη-ατομικά παίγνια δείτε π.χ. [74], όπου όρια στο τιμήμα της αναρχίας δίνονται που εξαρτώνται στην πραγματικότητα μόνο από την τάξη των συναρτήσεων κόστους, των πόρων και είναι ανεξάρτητη από την τοπολογία του δικτύου και [28], όπου μια απλούστερη απόδειξη του προηγούμενου αποτελέσματος δόθηκε που επίσης μπορεί να εφαρμόζεται σε πιο γενικές περιπτώσεις. Επίσης, θα μπορούσαμε να δούμε το [64], όπου δείχνετε ότι οι τοπολογικές ιδιότητες μπορεί να βοηθήσουν το δίκτυο.

Για αποτελέσματα για το τιμήμα της αναρχίας σε ατομικά παιχνίδια δείτε π.χ. [8], όπου τα όρια τιμήματος της αναρχίας δίνονται για τις περιπτώσεις όπου το κόστος είναι γραμμικές συναρτήσεις ή τα πολυώνυμα βαθμού  $\delta$ , [23], όπου επίσης όρια (ελαφρώς ισχυρότερα για ορισμένες περιπτώσεις) για περιπτώσεις όπου το κόστος είναι γραμμικές συναρτήσεις ή πολυώνυμα βαθμού  $\delta$  είναι δεδομένο, αλλά επίσης μια πιο γενική μέθοδος, για οριοθέτηση

του τιμήματος της αναρχίας εισάγεται και [4], όπου δίνονται τα ακριβή όρια χρησιμοποιώντας παρόμοιες τεχνικές με το [23] που επίσης ισχύει για τη ΠΣ με βάρη.

Για αποτελέσματα σχετικά με τη σύγκλιση σε *PNE* δείτε π.χ. [32], όπου όρια για το χρόνο σύγκλισης για μονήρεις ΠΣ (στρατηγικές είναι *singletons*) για βεβαρυμένα ή μη βεβαρυμένα ΠΣ, [39], όπου, μεταξύ άλλων, εξετάζεται η σύγκλιση σε *PNE* για την περίπτωση του δικτύου Γς με γραμμικά ανεξάρτητα μονοπάτια.

Για αποτελέσματα σχετικά με την σύγκλιση σε προσεγγιστική ισορροπία *Nash* (όπου τα κόστη των παιτών είναι "περίπου" ίσα) βλέπε π.χ. [80], όπου ισχυρή αποτελέσματα δυσκολίας σχετικά με τους χρόνους της σύγκλισης, της καλύτερη απάντηση δυναμική είναι κενές, [21], όπου τα θετικά αποτελέσματα για την ταχύτητα της σύγκλισης σε συμμετρικά παίγνια δίδονται, [9], όπου το παραπάνω έργο εκτείνεται στην ασύμμετρη περίπτωση όταν μια ειδική ιδιότητα που βοηθά να παρακάμψει το *inapproximability* χρησιμοποιείται, τα [80] και [1] που ιδιότητες των χώρων στρατηγικών διερευνώνται έτσι ώστε να έχουν γρήγορη σύγκλισης.

Για παίγνια με παικτοεξαρτώμενες συναρτήσεις κόστους π.χ. δείτε το [63], όπου η μελέτη της ΠΣ με παικτοεξαρτώμενες συναρτήσεις άρχισε για *singleton* ΠΣ, [2], όπου, μεταξύ άλλων, διαερυνήθηκαν αγγυήσεις για ύπαρξη *PNE* είναι ερευνήσε, [61], όπου οι διαφορές μεταξύ των παικτοεξαρτώμενων συναρτήσεων είναι μόνο σταθερές, [2], όπου τα δίκτυα που βρέθηκαν στο [61] αποδεικνύονται να είναι βέλτιστα τοπολογικά και ένας πολυωνυμικός αλγόριθμος για εύρεση της εγγυημένης για ύπαρξη καθαρής *PNE* δίνεται και [46] που ιδιότητες της κλάσης συναρτήσεων διερευνώνται και για τις δύο περιπτώσεις του βεβαρυμένων ή μη βεβαρυμένων ΠΣ προκειμένου να έχουν *PNE*.

Για παιχνίδια με βεβαρυμένους παίκτες βλέπε π.χ. [44], όπου το μοντέλο των βεβαρυμένων ΠΣ εισάγεται και τα αποτελέσματα σχετικά με την ύπαρξη της ισορροπίας και πιθανές λειτουργίες παρουσιάζονται, [69] για πειραματικά αποτελέσματα στο μοντέλο του [44], [2] όπου, όπως και στα παίγνια με παικτοεξαρτώμενες συναρτήσεις, διερευνώνται γενικότερα δίκτυα για το αν εγγυώνται την ύπαρξη *PNE*, [14], όπου το τίμημα της αναρχίας (όποτε υπάρχει ένα ΠNE) σχετίζεται με την κατηγορία των επιτρεπόμενων συναρτήσεων κόστους και η χειρότερη περίπτωση αποτελέσματος αποδεικνύονται να έχουν σε στενή σχέση με το αντίστοιχα σε μη βεβαρυμένα παίγνια, [65], όπου παρουσιάζονται οι τοπολογικές ιδιότητες να σχετίζονται έντονα με την ύπαρξη της *PNE* και [50], όπου δίνεται ένας ακριβής χαρακτηρισμός του συνόλου των συναρτήσεων κόστους που εγγυώνται μια ύπαρξη *PNE*.

### Παίγνια ακμών συμφόρησης.

Για αποτελέσματα σε μη-ατομικά παίγνια δείτε π.χ. [27], όπου η θεωρητική μελέτη τέτοιων παιγνίων ξεκίνησε και [62], όπου η μοναδικότητα και βελτιστοποίησης της *PNE* εξετάζεται σε παράλληλα δίκτυα, σειριακά παράλληλα και γενικά δίκτυα. Για αποτελέσματα σχετικά με το παράδοξο του Βραεος βλέπε ενότητα 1.3.

Για αποτελέσματα σε ατομικά παιχνίδια δείτε π.χ. το [11], όπου η μελέτη για ατομικές παίγνια ξεκίνησε, αποδείχτηκε η μη μοναδικότητα της *PNE*, μελετήθηκαν ταχύτητα σύγκλισης και όρια στο τμήμα της αναρχίας όταν ισορροπία μπορεί να επιτευχθεί, [18], όπου τα αποτελέσματα για το τμήμα της αναρχίας όσον αφορά τη διάρθρωση του δικτύου παρουσιάζονται και η ύπαρξη μιας κοινωνικά βέλτιστης *PNE* επίσης έχει αποδειχθεί, [31], όπου δίνονται ολοκληρωμένοι χαρακτηρισμοί από τα δίκτυα που έχουν βέλτιστο τμήμα της αναρχίας δίνεται (σειριακά παράλληλα δίκτυα και μια άλλη εκδοχή ισορροπίας που καθορίζονται σε αυτήν) και [19], όπου αποτελέσματα που σχετίζονται με την ύπαρξη, πολυπλοκότητα, και το τμήμα αναρχίας της *PNE* για αρκετά δικτυακά παίγνια (συμμετρικές και ασύμμετρες, με πανομοιότυπους ή βεβαρυσμένους παίκτες) δίνονται.

## 1.3 Βελτιώνοντας το τμήμα της αναρχίας

Η υποβάθμιση του δικτύου λόγω εγωιστικής συμπεριφορά παικτών τράβηξε πολύ προσοχή στο παρελθόν. Στη βιβλιογραφία, υπάρχουν τρεις επικρατούσες τεχνικές για να αντιμετωπίσουμε αυτή την υποβάθμιση.

- Φορολόγηση των ακμών: αλλάζοντας τις συναρτήσεις του κόστους των παικτών με την προσθήκη φόρων στις ακμές (πόρους) του δικτύου.
- Στρατηγικές *Stackelberg*: αλλάζει το κλάσμα των εγωιστών παικτών θεωρώντας ότι κάποιοι παίκτες είναι πρόθυμοι να συνεργαστούν για την κοινωνική ευημερία.
- Αποφυγή παράδοξου του Μπραεος: αλλαγή της τοπολογίας του δικτύου κάνοντας μερικές ακμές (πόρους) μη διαθέσιμες.

### 1.3.1 Φορολόγηση των ακμών

Ένα παίγνιο συμφόρησης με φόρους είναι ένα τυπικό ΠΣ με ένα διάνυσμα επιπλέον φόρων που δίνει το φόρο για τις ακμές του δικτύου. Τα κόστη των παικτών έχουν τροποποιηθεί έτσι ώστε να εμπεριέχουν επίσης το κόστος λόγω φόρων στις άκρες που επιλέγουν. Οι παίκτες μπορεί να έχουν διαφορετικές

ευαισθησίες σε φόρους και που παγιδεύεται από μια σταθερά που έρχεται μαζί με κάθε παίκτη. Οι φόροι αυξάνουν το κόστος των παικτών, χωρίς να επηρεάζουν το κοινωνικό κόστος και έτσι μπορεί να χρησιμοποιηθεί χωρίς χρέωση από το διαχειριστή δικτύου. Στην ιδανική περίπτωση, ένας θα ήθελε, με τη φορολόγηση των ακμών, να είναι οι ισορροπίες Nash στο νέο παιχνίδι βέλτιστες ροές στο αρχικό παιχνίδι. Τέτοιου είδους φόροι ονομάζονται βέλτιστοι φόροι.

### Μη ατομική περίπτωση.

Σε μη-ατομικά παίγνια, το θέμα του σχεδιασμού βέλτιστων φόρων έχει μελετηθεί εκτενώς. Ένα κλασικό αποτέλεσμα που πηγαίνει πίσω στο *Pigou* [70] αναφέρει ότι οι *marginal cost* φόροι μπορούν να προκαλέσει τη βέλτιστη ροή για ομοιογενή παίκτες [13]. Πρόσφατες εργασίες, περί των φόρων, για μη ατομικό ΠΣ θεωρεί την πιο ενδιαφέρουσα και ρεαλιστική υπόθεση ετερογενή παικτών, οι οποίοι μπορεί να έχουν διαφορετικές εκτιμήσεις του χρόνου (καθυστέρηση) σε χρήμα (φόροι). *Yang* και *Huang*, [85] κατέδειξε την ύπαρξη πρακτικής βέλτιστων φόρων για μη ατομικό ασύμμετρη δικτυακά ΠΣ με ετερογενείς παίκτες. Στη συνέχεια, το αποτέλεσμα επανανακαλύφθηκε από *Fleischer*, *Jain*, και *Mahdian* [36], και Καρακώστας Κολλιόπουλος [54]. Προηγουμένως, τα *singlesource* δίκτυα είχαν ερευνηθεί από *Cole*, *Dodis* και *Roughgarden* [26]. Την ύπαρξη βέλτιστων φόρων για μη ατομικό ΠΣ με ετερογενείς παίκτες από τη δυσκολία στο γραμμικό προγραμματισμό ([36, 54]), και έτσι μια βέλτιστη ανάθεση φόρων μπορεί να υπολογιστεί αποτελεσματικά από την επίλυση ενός γραμμικού προγράμματος. Για μη-ατομικής παιχνίδια, κάτω από ήπιες παραδοχές σχετικά με τις λειτουργίες του λανθάνουσα κατάσταση η άκρη ροή σε κατάσταση ισορροπίας είναι μοναδική. Ως εκ τούτου, οι φόροι των [13, 26, 36, 54, 85] κάνουν τη βέλτιστη λύση ως τη μοναδική ροή ισορροπίας του παιχνιδιού με φόρους.

### Ατομική περίπτωση.

Σε ατομικά ΠΣ, ακόμη και με διαιρούμενη κυκλοφορίας (οι παίκτες μπορούν να χρησιμοποιούν περισσότερες από μία διαδρομές για την ροή τους), μπορεί να δεχθεί πολλές διαφορετικές ροές ισορροπίας Nash, ενδεχομένως με διαφορετικό ροή στις ακμές. Ως εκ τούτου, κατά την εξέταση ατομικών ΠΣ, πρέπει να γίνει διάκριση μεταξύ

- *weakly optimal* φόρων, για τους οποίους τουλάχιστον μία ισορροπία Nash του παιχνιδιού με φόρους, ελαχιστοποιεί τη συνολική καθυστέρηση, και
- *strongly optimal* φόρων, για τους οποίους όλες οι ισορροπίες Nash του παιχνιδιού με τους φόρους να ελαχιστοποιούν τη συνολική καθυστέρηση.

Για ατομικό ΠΣ με διαιρούμενων κυκλοφορίας και ετερογενή παίκτες, στο *Swamy* [81] αποδείχθηκε ότι *weakly optimal* φόροι υπάρχουν και μπορεί να υπολογιστούν αποτελεσματικά. Στην πραγματικότητα μπορεί να υπολογιστεί λύνοντας ένα κυρτό πρόγραμμα παρόμοιο με αυτά στα [36] και [54]. Όσο για την ατομική περίπτωση ΠΣ με *unsplittable* κυκλοφορία, έχει μελετηθεί η ύπαρξη και ο αποτελεσματικός υπολογισμός βέλτιστων φόρων με ομοιογενείς παίκτες. Καραγιάννης, Κακλαμάνης και Κανελλόπουλος [20] θεώρησαν ατομικά παίγνια με γραμμικές συναρτήσεις καθυστέρησης και ομοιογενείς παίκτες και διερευνήθηκαν φόροι που μπορεί να βελτιώσει το τμήμα της αναρχίας. Στην αρνητική πλευρά, είτε αν οι παίκτες δεν μοιράζονται την ίδια πηγή και τερματισμό είτε έχουν διαφορετικές απαιτήσεις, τότε *strongly optimal* φόροι δεν μπορεί να υπάρχουν. Από τη θετική πλευρά, παρουσίασαν μια αποδοτική κατασκευή *strongly optimal* φόρων για *parallel link* παιχνίδια με γραμμικές συναρτήσεις και *unit demand* παίκτες.

Στη συνέχεια, οι Φωτάκης και Σπυράκης [45] απέδειξαν ότι *weakly optimal* φόροι υπάρχουν και μπορεί να υπολογιστούν αποτελεσματικά για ατομικά συμμετρικά δικτυακά ΠΣ, και ότι οι φόροι είναι *strongly optimal*, αν το δίκτυο είναι *series parallel*. Για την περίπτωση με ετερογενείς παίκτες, αποτελέσματα με παρόμοια τεχνική με αυτή που χρησιμοποιείται στην περίπτωση μη ατομικών παιγνίων. Οι Φωτάκης, Καρακώστας και Κολλιόπουλος [43], χρησιμοποιώντας ένα γραμμικό πρόγραμμα όπως στο [54], αποδεικνύουν την ύπαρξη των ασθενώς βέλτιστων φόρων για παίγνια με ετερογενή παίκτες με τον ίδιο κόμβο πηγή. Επίσης, στο [43], δίνεται ένα παράδειγμα μετρητή που δείχνει ότι η ετερογένεια των παικτών αποκλείει την ύπαρξη των φόρων *strongly optimal* ακόμη και για την απλούστερη τοπολογία των *parallellinks*.

### Περιορισμοί στους επιτρεπόμενους φόρους.

Πιο πρόσφατα, οι *Hoefler* και άλλοι ([51]) μελέτησαν μη ατομικά ΠΣ με φόρους, όπου μόνο ένα υποσύνολο των πόρων έχει τη δυνατότητα να πάρει φόρους και, στην αρνητική πλευρά παρείχαν ΝΠ δυσκολίας αποτελέσματα για την εύρεση βέλτιστων φόρων για γενική δίκτυα με γραμμικές συναρτήσεις καθυστέρησης και δύο βασικών προϊόντων, ενώ από τη θετική πλευρά, για *single commodity* δίκτυα με παράλληλες συνδέσεις και γραμμικές συναρτήσεις, παρείχαν αλγόριθμο πολυωνυμικού χρόνου για την εύρεση βέλτιστων φόρων.

Ακολουθώντας, οι *Bonifaci* και άλλοι ([17]) μελέτησαν την περίπτωση (μη ατομικής) όπου μαζί με την κάθε ακμή, ένα ανώτερο όριο για το επιτρεπόμενο φόρο στην κάθε ακμή δίνεται. Παρέχουν ένα χαρακτηρισμό για τις ροές που μπορούν να επιβληθούν από τους περιορισμένους φόρους και υπολογίζουν τους βέλτιστους φόρους όταν η βέλτιστη ροή είναι *inducible*. Επίσης με βάση



αυτό το χαρακτηρισμό, καταφέρνουν να υπολογίσουν τους φόρους που θα προκαλέσει το μικρότερο κόστος σε κατάσταση ισορροπίας, για παράλληλων συνδέσεων δίκτυα. Επίσης βγάζουν σφιχτά (ακόμη και για παράλληλων συνδέσεων δίκτυα) όρια για την αποτελεσματικότητα των περιορισμένων διοδίων για δίκτυα πολυπροϊοντικά με πολυωνυμικές συναρτήσεις καθυστέρησης.

Η *Jelinek* και άλλοι στο [53] γενικεύουν το παραπάνω μοντέλο ατομικών ΠΣ και ΠΣ με φόρους με ετερογενή παίκτες. Για μη ατομικά παίγνια και ετερογενείς παίκτες, αποδεικνύουν ότι το πρόβλημα είναι ΝΠ δύσκολο ακόμα και για δίκτυα *singlecommodity* και αφινικές συναρτήσεις καθυστέρησης. Στη θετική πλευρά δίνουν έναν αλγόριθμο βέλτιστης φορολόγησης υποδικτύων με αφινικές συναρτήσεις. Για βεβαρυμένους ατομικούς παίκτες, το πρόβλημα είναι ΝΠ σκληρό ήδη για *parallel arc* δίκτυα και γραμμικές συναρτήσεις καθυστέρησης, ακόμη και αν οι παίκτες είναι ομοιογενείς. Εστιάζοντας σε παράλληλων συνδέσεων παίγνια, για μη βεβαρυμένα ατομικά παίγνια και ομοιογενείς παίκτες, αναπτύσσουν έναν αλγόριθμο για τον υπολογισμό βέλτιστων περιορισμένων φόρων και για μη βεβαρυμένα ατομικά παίγνια και ετερογενή παίκτες, αντλούν έναν αλγόριθμο για βέλτιστη φορολόγηση υποδικτύων.

### 1.3.2 Αποφυγή του παραδόξου του Μπραες

Το παράδοξο του Βραες είναι η μη διαισθητική παρατήρηση, ότι αφαιρώντας ακμές από ενός δίκτυο, η απόδοσή του μπορεί να αυξηθεί. Τα σχήματα 8.2 και 8.3 είναι παραδείγματα του παραδόξου.

Η ιδέα είναι να βελτιώσεις τις επιδόσεις του δικτύου σε κατάσταση ισορροπίας, αξιοποιώντας την ουσία το Βραες παράδοξο, να αφαιρέσει μερικές ακμές του δικτύου, προκειμένου να μειωθεί η καθυστέρηση της ροής Ναση (της ροής που προκαλείται από την ισορροπία Ναση). Έτσι, δοθέντος ΠΣ, αναζητούμε το καλύτερο υποδίκτυο, δηλαδή το υποδίκτυο που ελαχιστοποιεί την κατάσταση των παικτών σε ισορροπία (χειρότερη).

Οι *Valiant* και *Roughgarden* [83], προκειμένου να στηρίξουν θεωρητικά το παράδοξο του Βραες και να δείξουν ότι δεν είναι ένα κατασκευάσμα της θεωρίας, αποδείχθηκε ότι (υπό προσθετικά κόστη) το παράδοξο εμφανίζεται με μεγάλη πιθανότητα σε τυχαία δίκτυα, και ότι για μια φυσική διανομή των συναρτήσεων, απομάκρυνση ακμών μπορεί να βελτιώσει, με μεγάλη πιθανότητα, την κατάσταση ισορροπίας κατά ένα σταθερό παράγοντα.

Στην ίδια κατεύθυνση, οι *Chung* και *Young* στο [24], υιοθετώντας το μοντέλο τυχαίων γραφημάτων των *Erdos–Renyi* έδειξε ότι το παράδοξο του Βραες εμφανίζεται όταν  $np \geq c \log(n)$  για κάποια  $c > 1$  ( $n, p$  τυχαίες παράμετροι του γραφήματος). Δείτε επίσης: [47] για μια μικρή γενίκευση από τους ίδιους.

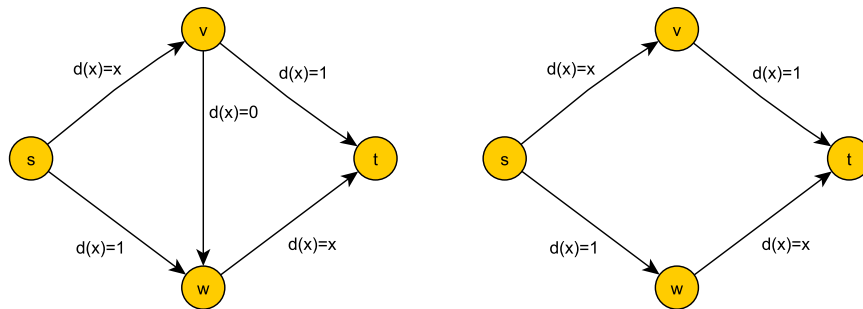

**Σχήμα 1.2:** Μια μονάδα ροής πρόκειται να μεταφερθεί από τον κόμβο  $s$  στον κόμβο  $t$ . (α). Η βέλτιστη λύση με προσθετικά κόστη δρομολογεί  $1/2$  μνάδες ροής στο πάνω μονοπάτι  $(s, v, t)$  και  $1/2$  ροή στο κάτω μονοπάτι  $(s, w, t)$ , και μπετυχαίνει συνολικό κόστος  $3/2$ . Στην ισορροπία *Nash*, όλη η ροή πηγαινει μέσα από το μονοπάτι  $(s, v, w, t)$ . Οι καθυστερήσεις των παικτών ισούνται με 2, κι έτσι το τιμημα της ανρχίας είναι  $4/3$ . (β). Χωρίς την ακμή  $(v, w)$ , η ισορροπία *Nash* και η βελτιστη ροή ταυτίζονται.

### Παίγνια με προσθετικά κόστη.

Δυστυχώς, στο [77] ο *Roughgarden* αποδεικνύει ότι είναι *NP* δύσκολο όχι μόνο να βρείς το καλύτερο υποδίκτυο, αλλά επίσης να υπολογιστεί κάποια ουσιαστική προσέγγιση για το καλύτερο υποδίκτυο. Ειδικότερα, έδειξε ότι ακόμη και για γραμμικές συναρτήσεις, είναι δύσκολο να γίνει διάκριση μεταξύ περιπτώσεις χωρίς παράδοξο, όπου με απομάκρυνση ακμής δεν μπορεί να βελτιωθεί η κατάσταση ισορροπίας, και *paradox ridded*, όπου η συνολική αδράνεια της ροής *Nash* για το καλύτερο υποδίκτυο είναι ίση με το βέλτιστο συνολικό (δηλαδή, αφαίρεσης ακμής μπορεί να μειώσει το τιμημα της ανρχίας στο 1). Αυτό σημαίνει ότι ο μόνος γνωστός αλγόριθμος προσέγγισης για το καλύτερο υποδίκτυο είναι αυτός που δεν αφαιρεί οποιαδήποτε ακμές!

Οι Φωτάκης, Καπόρης και Σπυράκης ([42]) εξέτασαν το παράδοξο του *Braess* για μερικά πρακτικά ενδιαφέροντα στιγμυότυπα και έδωσαν έναν πολυωνυμικού χρόνου αλγόριθμο που αποφασίζει αν ένα δίκτυο είναι *paradox ridded*, όταν οι συναρτήσεις είναι γραμμικές και αυστηρά αύξουσες, ενός *polynomial time* αλγορίθμου για το πρόβλημα της εξεύρεσης το καλύτερο υποδίκτυο, που ξεπερνά οποιαδήποτε γνωστή προσέγγιση για την περίπτωση γραμμικών αυξουσών συναρτήσεων και ένας αλγόριθμος για την εύρεση ένα υποδικτύου που είναι σχεδόν βέλτιστη ωρι λανθάνουσα κατάσταση ισορροπίας, η οποία είναι *subexponential*, όταν ο αριθμός των διαδρομών είναι πολυωνυμική και κάθε διαδρομή έχει μήκος *polylogarithmic*. Αποδεικνύουν επίσης ότι το πρόβλημα απόφασης αν ένα δίκτυο με αυθαίρετη γραμμικές συναρτήσεις έχει το παράδοξο ανάγεται στο πρόβλημα παραγωγής όλων των

βέλτιστων λύσεων της ένα γραμμικό πρόγραμμα.

Ως προέκταση δείχνουν μιας πολυωνυμικού χρόνου μέθοδο που μετατρέπει τη βέλτιστη ροή σε μια Nash ροή με τη διαγραφή ακμών που δεν χρησιμοποιούνται από τη βέλτιστη ροή, και με ελάχιστες τροποποιήσεις των *latencies* στις υπόλοιπες ακμές. Από τα αρνητικά αποτελέσματα του *Roughgarden*, η προσπάθεια εντοπισμού του *Braess* παραδόξου δεν έμοιαζε να έχει κίνητρα. Λαμβάνοντας υπόψη τα αποτελέσματα του [42] εν τούτοις, το πρόβλημα γίνεται πολύ πιο ενδιαφέρον.

### Παίγνια με κόστη ακμής συμφόρησης.

Κάθε παίγνιο με ακμή συμφόρησης είναι γνωστό ότι έχει μια ροή Nash που είναι βέλτιστη για το δίκτυο, με την έννοια ότι ελαχιστοποιεί ητ μέγιστη καθυστέρηση σχετικά με οποιαδήποτε χρησιμοποιούνται ακμή, γνωστός και ως το κόστος της συμφόρησης του δικτύου (π.χ. δείτε [11]). Από την άλλη πλευρά, παίγνια με ακμή συμφόρησης έχουν συνήθως πολλές διαφορετικές ροές Nash, μερικές αρκετά μακριά από το βέλτιστο κόστος. Ως εκ τούτου, έχει υπάρξει ένα σημαντικό ενδιαφέρον για την ποσοτικοποίηση της υποβάθμισης της απόδοσης λόγω των μη συνεργατικών παικτών και της εγωιστικής συμπεριφοράς σε (διάφορες παραλλαγές των) παιγνίων με ακμή συμφόρησης. Απλά παραδείγματα (βλέπε, π.χ., σχήμα 8.2 ή [27, σχήμα 2]) αποδεικνύουν ότι το τίμημα της αναρχίας σε παίγνια με γραμμικές συναρτήσεις μπορεί να είναι τόσο μεγάλο ως  $n$ , όπου  $n$  είναι ο αριθμός των κορυφών του δικτύου.

Για παίγνια με ακμή συμφόρησης, όπου ο πληθυσμός των παικτών είναι πεπερασμένος, και κάθε παίκτης ελέγχει ένα *nonnegligible* ποσό της κυκλοφορίας, η οποία μπορεί να χωριστεί ανάμεσα σε διαφορετικά μονοπάτια, οι *Banner* και *Orda* [11] παρατήρησε ότι το τίμημα της αναρχίας μπορεί να είναι απεριόριστο, ακόμη και για πολύ απλά δίκτυα, αν οι παίκτες έχουν διαφορετικές αφετηρίες και προορισμούς και εκθετικές συναρτήσεις καθυστέρησης. Από την άλλη πλευρά, οι *Banner* και *Orda* απέδειξαν ότι αν οι παίκτες χρησιμοποιούν διαδρομές που ελαχιστοποιούν τις ακμές συμφόρησης, τότε όλες οι ροές Nash είναι βέλτιστες. Για μια παραλλαγή όπου το κοινωνικό κόστος είναι το κόστος του μέσου (αντί για το μέγιστο) οι *Cole*, *Dodis*, και *Roughgarden* [27] απέδειξαν ότι το τίμημα της αναρχίας είναι  $4/3$ , οριστεί μια νέα ισορροπία, υποσύνολο των *Nash* ισορροπιών, που ονομάζεται *subpathoptimal Nash* ρέει, θεωρείται μόνο.

Στη συνέχεια, οι *Mazalov* και άλλοι [62] έδειξαν την αναποτελεσματικότητα στη ροή του Nash υπό την έννοια αυτή του κοινωνικού κόστους. Για ατομικά *unsplittable* παίγνια με ακμή συμφόρησης, όπου κάθε παίκτης δρομολογεί μια μονάδα της κυκλοφορίας μέσω ενός μονοπατιού, οι Βανερ και Ορδα [11] αποδεικνύουν ότι για πολυωνυμικές συναρτήσεις βαθμού  $\delta$ , το

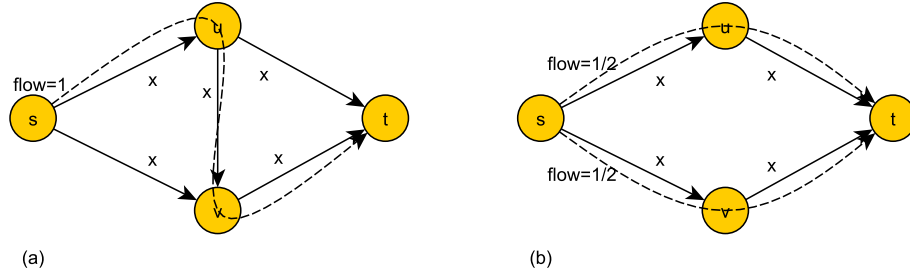

**Σχήμα 1.3:** Ένα παράδειγμα του παραδόξου παίγνια ακμών συμφόρησης. Θεωρούμε ένα παίγνιο συμφόρησης με ταυτοτικές συναρτήσεις καθυστέρησης και μια μονάδα ροής πρέπει να μεταφερθεί από τον  $s$  στον  $t$ . Η χειρότερη ισορροπία, στο (α), περνάει όλη τη ροή από το  $(s, u, v, t)$ , και έχει κόστος ίσο με 1. Από την άλλη μεριά, η βέλτιστη ροή περνά  $1/2$  μονάδες ροής μέσα από το μονοπάτι  $(s, u, t)$  και  $1/2$  μονάδες ροής από το  $(s, v, t)$ , και έχει κόστος  $1/2$ . Άρα,  $\text{PoA} = 2$ . Στο υποδίκτυο (β), που το παίρνουμε αν αφαιρέσουμε την ακμή  $(u, v)$ , έχουμε μοναδική ισορροπία *Nash* που συμπίπτει με την βέλτιστη ροή, κι μέτσι το  $\text{PoA}$  γίνεται 1.

τίμημα της αναρχίας είναι  $O(md)$ , όπου  $m$  είναι ο αριθμός των ακμών του δικτύου.

Από την άλλη πλευρά, οι *Epstein* και άλλοι ([31]) αποδείχθηκε ότι για σειριακά παράλληλα δίκτυα με αυθαίρετες συναρτήσεις καθυστέρησης, όλες οι ροές *Nash* είναι βέλτιστες. Εκ των υστέρων, *Busch* και *Magdon – Ismail* [18] αποδεικνύουν ότι το τίμημα της αναρχίας σε ατομικά *unsplittable* παίγνια με ακμή συμφόρησης με ταυτοτικές συναρτήσεις καθυστέρησης μπορεί να οριοθετείται από τις φυσικές τοπολογικές ιδιοτήτες του δικτύου. Ειδικότερα, απέδειξαν ότι το τίμημα της αναρχίας αυτών των παιγνίων είναι οριοθετείται από πάνω από  $O(l + \log n)$ , όπου  $l$  είναι το μήκος της μεγαλύτερης  $s - t$  διαδρομής, και από  $O(k^2 + \log^2 n)$ , όπου  $k$  είναι το μήκος του μακρύτερου κύκλου. Για άλλη μια φορά, σε αυτή τη περίπτωση, ένας μπορεί να διακρίνει δύο ακραίες περιπτώσεις: περιπτώσεις χωρίς παράδοξο, όπου απομάκρυνση ακμής δεν μπορεί να βελτιώσει το κόστος χειρότερη *Nash* ισορροπίας, και γεμάτες παράδοξο περιπτώσεις, όπου το κόστος της χειρότερης *Nash* ισορροπίας στο καλύτερο υποδίκτυο είναι ίση με το κόστος συμφόρησης του δικτύου (δείτε επίσης: [77, 42]).

Το *approximability* του σχεδιασμού βέλτιστων υποδικτύων, για μια γενίκευση του σχεδιασμού όπου δεν μπορούμε να αφαιρούμε ορισμένες άκρες, θεωρήθηκε από τους *Hou* και *Zhang* [52]. Για ατομικά *unsplittable* παίγνια με ακμή συμφόρησης με διαφορετικές προελεύσεις και προορισμούς για κάθε παίκτη, απέδειξαν ότι εάν οι λειτουργίες στη λανθάνουσα κατάσταση είναι πολυώνυμα βαθμού  $d$ , είναι *NP* δύσκολη προσέγγιση του καλύτερου υποδικτύου με έναν παράγοντα  $O(m^{d-\epsilon})$ , για οποιαδήποτε σταθερά  $\epsilon > 0$ . Επι-

πλέον, για  $k$  – *splittable* παίγνια με ακμή συμφόρησης με πολλαπλά *origin destination* ζεύγη, απέδειξαν ότι είναι *NP* δύσκολος η προσέγγιση του καλύτερου υποδικτύου εντός σταθερού παράγοντα.

Ωστόσο, μια προσεκτική ματιά στη μείωση των [52] αποκαλύπτει ότι η ισχυρότητα των *inapproximability* αποτελεσμάτων εξαρτάται αποφασιστικά από (i) ότι μπορούμε μόνο να κατάργηση ορισμένων ακμές από το δίκτυο, έτσι ώστε το υποδίκτυο που πραγματικά μπορεί να προκαλεί υψηλό τίμημα της αναρχίας δεν μπορεί να καταστραφεί, και (ii) ότι οι παίκτες έχουν διαφορετικές αφετηρίες και προορισμούς (και επίσης είναι ατομικό και έχουν διαφορετικές ποσά κυκλοφορίας). Όσο για τη σημασία της (ii), σε μια διαφορετική περίπτωση, όπου το επιμέρους κόστος των παικτών είναι το άθροισμα των ψοστών των ακμών στην πορεία τους και το κοινωνικό κόστος είναι το κόστος της συμφόρησης του δικτύου, είναι γνωστό ότι Βραεσς του παράδοξο μπορεί να είναι δραματικά πιο σοβαρό για περιπτώσεις με πολλαπλά *origin destination* ζεύγη από ότι για περιπτώσεις με ένα ενιαίο *origin destination* ζευγάρι.

Πιο συγκεκριμένα, οι *Lin* και άλλοι στο [59] απέδειξαν ότι, αν οι παίκτες έχουν μια κοινή προέλευση και προορισμό, η απομάκρυνση το πολύ  $k$  ακμών από το δίκτυο δεν μπορεί να βελτιώσει την ισορροπία κόστους κατά ένα συντελεστή μεγαλύτερο από  $k + 1$ . Από την άλλη πλευρά, οι *Lin* και άλλοι [58] παρουσίασαν μια περίπτωση με δύο *origin destination* ζευγάρια όπου η αφαίρεση μιας ακμής βελτιώνει την ισορροπία κατά ένα παράγοντα  $2^{\Omega(n)}$ . Ως εκ τούτου, τόσο σε τεχνική όσο και σε εννοιολογικό επίπεδο, τα αποτελέσματα της μη προσεγγισιμότητας του [52] δεν ρίχνει πραγματικά φως σχετικά με την *approximability* του (απλού, μη επιλεκτικού) πρόβληματος σχεδιασμού βέλτιστων υποδικτύων, στην απλούστερη και πιο ενδιαφέρουσα περίπτωση παιγνίων με ακμή συμφόρησης με ένα κοινό *origin destination* ζευγάρι για όλους τους παίκτες.

## 1.4 Παίγνια με παίκτες ευαίσθητους στο ρίσκο

Οι περισσότερες εργασίες έρευνας σε ΠΣ ουσιαστικά αγνοούν το στοχαστικό χαρακτήρα στις καθυστερήσεις των ακμών, ένα χαρακτηριστικό γνώρισμα στις πιο πρακτικές εφαρμογές, και υποθέτουν ότι οι παίκτες επιλέγουν τις στρατηγικές τους με βάση την επακριβή γνώση των συναρτήσεων των ακμών. Αντίθετα, στην πραγματική ζωή σε δίκτυα μεταφορών ή σε δίκτυα τηλεπικοινωνιών οι παίκτες δεν μπορούν να προβλέψουν με ακρίβεια την πραγματική καθυστέρηση. Αυτό συμβαίνει όχι μόνο επειδή οι παίκτες δεν μπορούν να γνωρίζουν την ακριβή συμφόρηση σε κάθε ακμή, αλλά και λόγω των (εκ των προτέρων άγνωστων) εξωτερικών γεγονότων (π.χ., κάποια εργασία κατασκευ-

ής, ένα μικρό ατύχημα, μια αποτυχία σύνδεσης) που μπορεί να επηρεάσει τις συναρτήσεις των ακμών και να επιφέρει αβεβαιότητα. Είναι επομένως φυσικό να υποθέσουμε ότι οι παίκτες θα αποφασίσουν σχετικά με τις στρατηγικές τους με βάση μόνο τις εκτιμήσεις τους στη πραγματική καθυστέρηση, και το πιο σημαντικό, ότι θα έχουν απόλυτη επίγνωση της αβεβαιότητας και την πιθανή ανακρίβεια των εκτιμήσεών τους. Έτσι, για να προφυλαχθούν οι ίδιοι από μια αυξημένη καθυστέρηση, κάθε φορά που αυτό μπορεί να έχει μια σημαντική επίπτωση, οι παίκτες επιλέγουν ακμές με λίγη αβεβαιότητα (π.χ., άνθρωποι είτε λαμβάνουν μια ασφαλή διαδρομή ή σχεδιάζουν για μια *larger than usual* καθυστέρηση όταν πηγαίνουν για μια σημαντική συνάντηση).

Τέτοιοι συλλογισμοί δημιουργούν ΠΣ με στοχαστικές καθυστερήσεις και παίκτες ευαίσθητους στο ρίσκο, όπου αντί για τη διαδρομή που ελαχιστοποιεί την προβλεπόμενη (ή αναμενόμενη) καθυστέρηση, κάθε παίκτης επιλέγει μια πορεία που εγγυάται μια λογικά χαμηλή πραγματική καθυστέρηση με μια αρκετά υψηλή σιγουριά. Η πραγματική καθυστέρηση του κάθε παίκτη μπορεί να μοντελοποιηθεί από μια τυχαία μεταβλητή. Στη συνέχεια, μια κοινή παραδοχή είναι ότι οι παίκτες προσπαθούν να ελαχιστοποιηθεί είτε ένα κυρτό συνδυασμό στην μέση τιμή και τη διακύμανση της καθυστέρησης, ή ένα συγκεκριμένο *quantile* της κατανομής της καθυστέρησης (δείτε επίσης: [82, 34] για τις συναρτήσεις κόστους παικτών με ευαισθησία στο ρίσκο, και [72] σχετικά με πιθανούς τρόπους ποσοτικοποίησης του κινδύνου στη βελτιστοποίηση κάτω από αβεβαιότητα).

Μετά την παραπάνω κατεύθυνση έρευνας, οι *Ordonez* και *Stier – Moses* [68] θεωρούν μη ατομικά ΠΣ, όπου ο πληθυσμός των παικτών είναι άπειρος και κάθε παίκτης ελέγχει μια αμελητέα ποσότητα του φορτίου, και προτείνουν η κάθε διαδρομή να τιμωρείται με έναν πρόσθετο όρο που αυξάνει με την αποστρόφη του κινδύνου από τους παίκτες, καθώς και με την μέγιστη απόκλιση από την αναμενόμενη καθυστέρηση της διαδρομής (ωστόσο αυτός ο όρος δεν εξαρτάται από το πραγματικό φορτίο των ακμών). Για κάθε διαδρομή, ο πρόσθετος όρος μπορεί να επιλεχτεί είτε ως κλάσμα της (και αντίστοιχα ένα *quantile* μιας τυχαίας μεταβλητής ανάλογα) μέγιστης απόκλισης από την αναμενόμενη καθυστέρηση της διαδρομής, ή απλά, ως το άθροισμα των κλασμάτων της μέγιστης απόκλισης από την αναμενόμενη καθυστέρηση της ακμής στη διαδρομή, όπου ποσοτικοποιεί το *risk aversion* των παικτών. Υπό μερικές γενικές παραδοχές, το [68] αποδεικνύει ότι μια ισορροπία υπάρχει και είναι ουσιαστικά μοναδική σε όλες τις παραπάνω περιπτώσεις.

Στη συνέχεια, οι *Nikolova* και *Stier – Moses* στο [67] προτείνουν ένα μοντέλο με *risk averse* παίκτες, όπου κάθε παίκτης επιλέγει μια πορεία που ελαχιστοποιεί την αναμενόμενη καθυστέρηση συν ένα ποσοστό της τυπικής απόκλισης της καθυστέρησης, ποσοστό που ποσοτικοποιεί το *risk aversion* των παικτών. Θεώρησαν μη ατομικά και ατομικά ΠΣ, ως επί το πλείστον

με ομοιογενής παίκτες, που μοιράζονται την ίδια στάση απέναντι στον κίνδυνο, και διακρίνονται μεταξύ των υποθέσεων όπου η τυπική απόκλιση της καθυστέρησης μιας διαδρομής είναι εξωγενής, δηλ. αυτό εξαρτάται από το φορτίο των ακμών στη διαδρομή, και στην περίπτωση όπου η τυπική απόκλιση είναι ενδογενής, δηλαδή, είναι συνάρτηση του φορτίου. οι *Nikolova* και *Stier – Moses* [67] απέδειξαν ότι στην εξωγενή περίπτωση, που είναι παρόμοιο με το μοντέλο της [68], (μη ατομικά και ατομικά) τα στοχαστικά ΠΣ ουσιαστικά διατηρούν τις ιδιότητες των κλασικών ΠΣ : επιδέχονται μια συνάρτηση δυναμικού και, στη μη ατομική περίπτωση, μια μοναδική ισορροπία, καθώς και η αναποτελεσματικότητα των ισορροπιών μπορεί να οριοθετείται με ίδιο τρόπο με τα κλασικά ΠΣ. Στην ενδογενή περίπτωση, απέδειξαν ότι η μη ατομικά στοχαστικά ΠΣ επιδέχονται μια ισορροπία, η οποία δεν είναι απαραίτητη και μοναδική, αλλά δεν μπορεί να δεχθεί συνάρτηση δυναμικού. Επιπλέον, τα ατομικά στοχαστικά ΠΣ μπορεί να μην έχουν *PNE* ακόμη και στην απλή επέκταση παράλληλων δικτύων με 2 παίκτες και γραμμικές καθυστερήσεις.

Μετά από αυτό το πρόσφατο ερευνητικό έργο, μια καλύτερη κατανόηση των ιδιοτήτων των (ατομικών) ΠΣ με στοχαστικές καθυστερήσεις και παίκτες ευαίσθητους στο φόβο φαίνεται ουσιαστική, ενώ περιπτώσεις με ανομοιογενείς παίκτες απέναντι στο φόβο δεν έχουν μελετηθεί καθόλου.

Στην πραγματικότητα, υπάρχει ένα σημαντικός όγκος εργασιών για τις θεωρητικές και πρακτικές πτυχές των δικτύων μεταφοράς με αβέβαιες καθυστερήσεις (βλ. π.χ., συζήτηση και οι αναφορές στο [67]). Ωστόσο, αυτή τη γραμμή της έρευνας εστιάζεται στη μη ατομική περίπτωση και υιοθετεί ειδικές έννοιες του επιμέρους κόστους. Με κίνητρο εφαρμογές όπου οι παίκτες έχουν μόνο μερική γνώση του αριθμού των παικτών που συμμετέχουν στο παιχνίδι, οι *Ashlagi*, *Monderer* και *Tennenholtz* στο [7] θεώρησαν ΠΣ σε *parallel links* δίκτυα με στοχαστικούς παίκτες. Ωστόσο, το κόστος των παικτών στο μοντέλο τους είναι η αναμενόμενη καθυστέρηση της επιλεγμένης ακμής, και έτσι οι παίκτες είναι *risk neutral*. Μελέτησαν *mixed Nash* ισορροπίες, και απέδειξαν ότι μια γενίκευση της πλήρως μικτής ισορροπίας παραμένει μια μικτή ισορροπία, αν οι παίκτες είναι στοχαστικοί.





## Κεφάλαιο 2

### Συνεισφορά της Εργασίας

Τα Παίγνια Συμφόρησης αποτελούν ένα από τα πιο εκτενώς μελετημένα πεδία της αλγοριθμικής θεωρίας παιγνίων. Παρόλαυτα, όπως αναμενόταν υπάρχουν ακόμη ανοιχτά προβλήματα στην περιοχή.

Η στοχοποίησή μας ήταν διττή, αν και τελικά και τα δύο μέρη της συνδέονται. Στη μια κατεύθυνση ασχοληθήκαμε με προβλήματα σχετιζόμενα με το παράδοξο του *Braess* σε παίγνια με προσθετικά κόστη αλλά και σε παίγνια με κόστη συγκέντρωσης, παίγνια δηλαδή που το κόστος των μονοπατιών ισούτε με το κόστος της πιο ακριβής ακμής στο μονοπάτι, και με τα δύο προβλήματα να βρίσκονται στο χώρο των προβλημάτων που σχετίζονται με τη μείωση του τιμήματος της αναρχίας

Στην άλλη κατεύθυνση ασχοληθήκαμε με το πρόβλημα γενίκευσης των παιγνίων συμφόρησης με τρόπον ώστε οι τυχαιότητα στις συνασρτήσεις καθυστέρησης να λαμβάνεται υπόψιν, εστιάζοντας κατά βάση στην μοντελοποίηση της πηγής της αβεβαιότητας στις καθυστερήσεις των ακμών. Πέρα από τα αποτελέσματα για αυτό το μοντέλο, με έκπληξη διαπιστώσαμε ότι αυτή η μοντελοποίηση ρίχνει φως σε ένα νέο τρόπο μείωσης του τιμήματος της αναρχίας, αυτό είναι η εκμετάλλευση του φόβου των παικτών απέναντι στην αβεβαιότητα ώστε προσθέτοντας αβεβαιότητα σαν θόρυβο στους πόρους-ακμές του δικτύου να βελτιωθεί η απόδοσή του. Αν σκεφτούμε το τελευταίο γεγονός, οι δυο κατευθύνσεις της δουλειάς μας εννοποιούνται.

Παρακάτω περιληπτικά δίνουμε τη συνεισφορά μας σε κάθε ένα από τα προβλήματα που μελετήθηκαν ενώ στις σκόλουθες ενότητες μπαίνουμε σε περισσότερες λεπτομέρειες.

- Το παράδοξο του *Braess* στις διαφορετικές εκδόσεις των παιγνίων συμφόρησης με κόστη συγκέντρωσης δεν ήταν πλήρως κατανοημένο και εμείς καταφέραμε να καθαρίσουμε το πεδίο για την βασική εκδοχή αυτών των παιγνίων (υποενότητα 2.1 και κεφάλαιο 4).

- Τυχαία δίκτυα που έχουν μελετηθεί μέχρι σήμερα, με μεγάλη πιθανότητα πάσχουν από το παράδοξο του *Braess* όταν τα κόστη είναι προσθετικά. Καταφέραμε να δείξουμε ότι κατά μινα έννοια, ο τρόπος για να αποδείξεις το παραπάνω γεγονός μπορεί να χρησιμοποιηθεί για την εξάλειψη του παραδόξου σε αυτά τα δίκτυα (υποενότητα 2.2 και κεφάλαιο 5).
- Τα στοχαστικά παίγνια συμφόρησης και ο φόβος απέναντι στο ρίσκο έχουν τραβήξει πολύ προσοχή τα τελευταία χρόνια. Με τη δουλειά στο κεφάλαιο 6 (συνεισφορά στην υποενότητα 2.3), προχωράμε ένα βήμα ακόμη στην κατανόηση αυτής της κλάσης παιγνίων.
- Σε συγκεκριμένες περιπτώσεις, οι στοχαστικές καθυστερήσεις μπορούν να βελτιώσουν τη συμπεριφορά του δικτύου (βλ. [71]). Στο κεφάλαιο 7 (συνεισφορά στην υποενότητα 2.4), δείχνουμε πως μπορούμε να εκμεταλλευτούμε τον φόβο των παικτών και να βελτιώσουμε την απόδοση του δικτύου.

## 2.1 Παράδοξο του Μπραες σε Παίγνια με Κόστη Συγκέντρωσης

Ερευνούμε την προσεγγισιμότητα του προβλήματος σχεδιασμού υποδικτύων στην πιο απλή και φαινομενικά πιο εύκολα να προσεγγιστεί έκδοσή των παιγνίων με κόστη συγκέντρωσης (με ένα μόνο ζεύγος προέλευσης-προορισμού). Το κύριο αποτέλεσμα μας είναι ότι το πρόβλημα εύρεσης βέλτιστου υποδικτύου είναι δύσκολο να προσεγγιστεί μέσα σε εύλογους παράγοντες, ακόμη και αν έχουμε γραμμικές αυστηρά αύξουσες συναρτήσεις καθυστέρησης. Εξ όσων γνωρίζουμε, αυτή είναι η πρώτη δουλειά που ερευνά την επιπτώσεις του παράδοξου του Βραες και την προσεγγισιμότητα του προβλήματος σχεδιασμού υποδικτύων για τη βασική έκδοση των παιγνίων με κόστη συγκέντρωσης. Για την πρωτότυπη εργασία δείτε [41]. Το σχήμα 2.1 συλλαμβάνει το μοντέλο στο οποίο τα αποτελέσματα αυτής της εργασίας ισχύουν.

Στην ενότητα 4.2, χρησιμοποιούμε τεχνικές παρόμοιες με εκείνες του [31, 27], και δείχνουμε ότι τα παίγνια συμφόρησης δεν πάσχουν από το παράδοξο του *Braess*, είτε, εάν το δίκτυο είναι σειριακό-παράλληλο, ή αν λάβουμε υπόψη μόνο υποδιαδρομής-βέλτιστες Ναση ροές (ορισμός στην ενότητα 4.1).

Στην αρνητική πλευρά, στην ενότητα 4.3 δείχνουμε με μια αναγωγή από το 2 *Directed Disjoint path* πρόβλημα ότι ακόμη και για γραμμικές συναρτήσεις, είναι *NP* δύσκολο να αναγνωρίσουμε το παράδοξο (λήμμα 4.1). Στην πραγματικότητα, η αναγωγή δείχνει ότι είναι *NP* δύσκολο να γίνει διάκριση

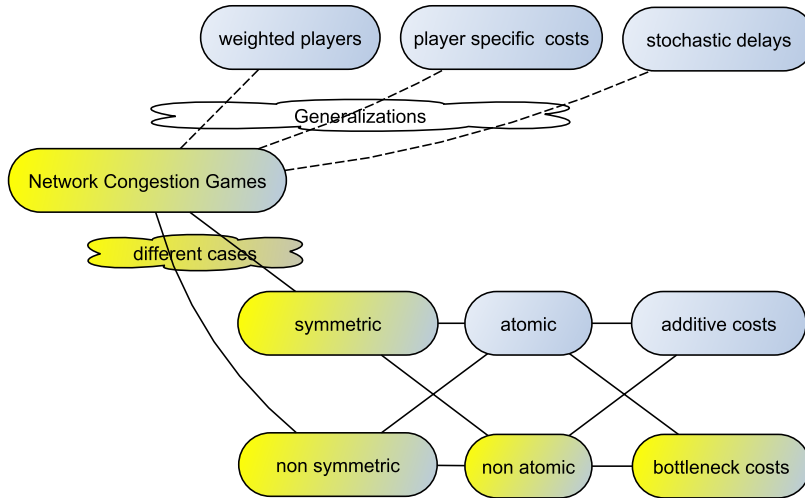

**Σχήμα 2.1:** Το κεντρικό αποτέλεσμα που ισχύει τόσο σε συμμετρικά όσο και σε μη συμμετρικά παίγνια με ακμές συγκέντρωσης.

μεταξύ *paradox ridden* περιπτώσεων (περιπτώσεις χωρίς κάθολου παράδοξο) και περιπτώσεων χωρίς παράδοξο, και κατά συνέπεια, είναι *NP* δύσκολο να προσεγγίσουν το πρόβλημα σχεδιασμού δικτύου εντός παράγοντος μικρότερου του  $4/3$ .

Στην ενότητα 4.4, εφαρμόζουμε ουσιαστικά την ίδια αναγωγή, αλλά με έναν επαναλαμβανόμενο τρόπο, και αποδεικνύουμε ένα πολύ ισχυρότερο αποτέλεσμα η προσεγγισιμότητας. Ειδικότερα, μπορούμε αν υποθέσουμε την ύπαρξη ενός *gap*, η οποία μας βεβαιώνει ότι η εύρεση του καλύτερου υποδικτύου είναι μη προσεγγίσιμος μέσα σε έναν παράγοντα μικρότερο από  $\gamma$ , με κατασκευή παρόμοια με αυτή του λήμματος 4.1 αλλά με μερικές ακμές αντικαταστημένες από αντίγραφα του δικτύου που δίνει το συγκεκριμένο *gap*, να ενισχύσουμε το *inapproximability gap* με συντελεστή  $4/3$ , αυξάνοντας παράλληλα βέβαια το μέγεθος του δικτύου περίπου κατά έναν παράγοντα 8 (λήμμα 11.4). Ως εκ τούτου, ξεκινώντας από το *gap*  $4/3$  που δίνεται από το λήμμα 4.1, και αναδρομικά εφαρμόζοντας αυτή της κατασκευή ένα λογαριθμικό αριθμό φορών, δείχνουμε ότι είναι *NP* δύσκολο να προσεγγίσουμε το πρόβλημα σχεδιασμού δικτύου για παίγνια με γραμμικές συναρτήσεις καθυστέρησης μέσα σε έναν παράγοντα  $O(n^{0.121-\epsilon})$ , για οποιαδήποτε σταθερά  $\epsilon > 0$ . Ένα ενδιαφέρον τεχνικό σημείο είναι καταφέρνουμε να δείξουμε αυτό το *inapproximability* αποτέλεσμα, ακόμα κι αν δεν ξέρουμε πώς να υπολογίσουμε την χειρότερη ισορροπία στο υποδίκτυο. Η αναγωγή μας χρησιμοποιεί την συγκεκριμένη δομή του υποδικτύου για τον εντοπισμό καλής προσέγγισης για το καλύτερο υποδίκτυο. Εξ όσων γνωρίζουμε, αυτή είναι η πρώτη

φορά που μια παρόμοια αναδρομική κατασκευή χρησιμοποιήθηκε για να μεγαλώσει το όριο μη προσεγγισιμότητας του προβλήματος σχεδιασμού δικτύων αλλά και για οποιοδήποτε άλλο πρόβλημα βελτιστοποίησης που σχετίζονται με την εγωιστική δρομολόγηση.

Στο τμήμα 4.5, θεωρούμε συναρτήσεις καθυστέρησης που πληρούν την προϋπόθεση *Lipschitz* και παρουσιάζουμε έναν αλγόριθμο για την εύρεση ένα υποδικτύου που είναι σχεδόν βέλτιστο όσον αφορά το κόστος στην χειρότερη Nash ισορροπία, όταν η χειρότερη ροή Nash σε το καλύτερο υποδίκτυο δρομολογεί μια μη αμελητέα ποσότητα της ροής στις ακμές που χρησιμοποιούνται. Ο αλγόριθμος βασίζεται στο *Sparcification* λήμμα του *Althofer* ([5]), και από την πρόσφατη εφαρμογή στο [42]. Για οποιαδήποτε σταθερά  $\epsilon > 0$ , ο αλγόριθμος υπολογίζει ένα υποδίκτυο και μια  $\epsilon/2$  προσεγγιστική Nash ροή με κόστος το πολύ προσαυξημένο κατά  $O(\epsilon)$  σε σχέση με το κόστος στο βέλτιστο υποδίκτυο. Ο χρόνος τρεξίματος είναι περίπου  $P^{\text{poly}(\log m)/\epsilon^2}$ , και είναι *quasipolynomial*, όταν το πλήθος των μονοπατιών είναι *quasipolynomial*.

## 2.2 Παράδοξο του Μπραες σε Παίγνια με Προσθετικά Κόστη

Εφορμώντας από τα [24, 25, 84] που αποδεικνύουν ότι οι τυχαίοι *Erdos – Renyi*  $G(n, p)$  γράφοι είναι επιρρεπείς στο παράδοξο, υιοθετούμε μια καθαρά αλγοριθμική προσέγγιση. Εστιάζουμε στην τάξη των αποκαλούμενων καλών στιγμιοτύπων, που είναι περιπτώσεις δικτύων με τις ιδιότητες που χρησιμοποιούνται από τα [24, 84] για να αποδειχθεί η με μεγάλη πιθανότητα εμφάνιση του Βραεος παράδοξου στα τυχαία αυτά δίκτυα. Στην πραγματικότητα, κάποιος μπορεί εύκολα να βεβαιωθεί ότι τα τυχαία στιγμιοτύπα στα [24, 84] είναι καλά στιγμιοτύπα με μεγάλη πιθανότητα. Αποδεικνύουμε ότι σε πολλές ενδιαφέρουσες περιπτώσεις, μπορεί η προσέγγιση του καλύτερο υποδικτύου και της ισορροπίας αυτού να γίνει αποδοτικά εφικτή. Αυτό που μπορεί να είναι ακόμη πιο εκπληκτικό είναι ότι ο προσεγγιστικός μας αλγόριθμος βασίζεται στις επεκτατικές ιδιότητες των καλών στιγμιοτύπων, δηλαδή στις ίδιες ιδιότητες που χρησιμοποιούνται στα [24, 84] για την απόδειξη της με μεγάλης πιθανότητας ύπαρξης του παραδόξου στα καλά στιγμιοτύπα! Εξ όσων γνωρίζουμε, τα αποτελέσματά μας είναι τα πρώτα θεωρητικού χαρακτήρα που δείχνουν ότι το παράδοξο του *Braess* μπορεί να εξαλειφθεί αποτελεσματικά σε μια μεγάλη κατηγορία ενδιαφέρουσων περιπτώσεων. Για την πρωτότυπη εργασία δείτε το [41]. Το σχήμα 2.2 συλλαμβάνει το μοντέλο που θεωρείται σε αυτή την εργασία.

Τεχνικά, παρουσιάζουμε ουσιαστικά ένα προσεγγιστικό σχήμα. Για ένα

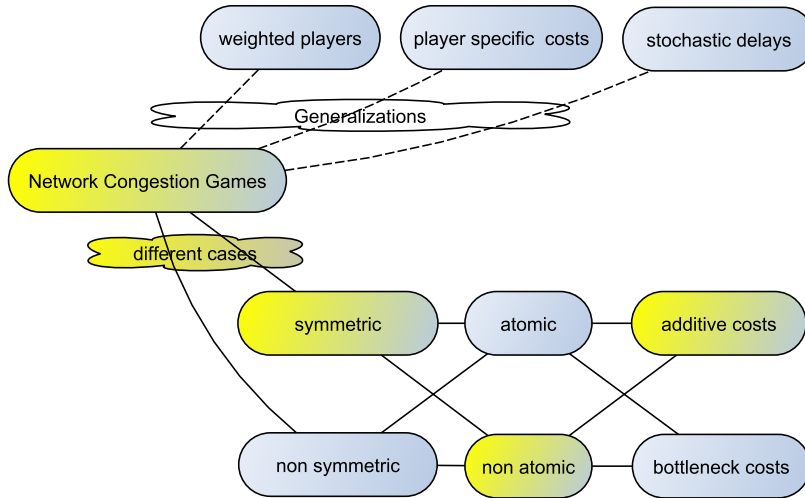

**Σχήμα 2.2:** Οι περιπτώσεις που τα τυχαία δίκτυα βρίσκονται

καλό στιγμυότυπο και κάθε σταθερά  $\epsilon > 0$ , υπολογίζουμε μια ροή  $g$  που είναι μια  $\epsilon$  Nash ροή για το υποδίκτυο που αποτελείται από τις ακμές που χρησιμοποιούνται από αυτήν, και έχει κόστος  $L(g) \leq (1 + \epsilon)L + \epsilon$ , όπου  $L$  είναι το κόστος της ισορροπίας στο καλύτερο υποδίκτυο (θεώρημα). Η ροή  $g$  έχει με μεγάλη πιθανότητα αυτές τις ιδιότητες. Τα αποτελέσματά μας ισχύουν για οποιοδήποτε δίκτυο στην κατηγορία των καλών στιγμυοτύπων. Αυτό, φυσικά, περιλαμβάνει τους  $G(n, p)$  γράφους με το  $p$  να είναι πάνω από το όριο συνεκτικότητας, αλλά επίσης μπορεί να περιλαμβάνει άλλους τύπους τυχαίων *expanders* (επεκτατών). Το ρηποσεγγιστικό μας σχήμα τρέχει σε πολυωνυμικό χρόνο για την πιο ενδιαφέρουσα περίπτωση, που το δίκτυο είναι σχετικά αραιό και το ποσό συνολικής κυκλοφορίας  $r$  είναι  $O(\text{poly}(\ln \ln n))$ , όπου  $n$  είναι ο αριθμός των κορυφών. Συγκεκριμένα, ο χρόνος τρεξίματος είναι πολυωνυμικός αν το καλό δίκτυο έχει μέσο βαθμό  $O(\text{poly}(\ln n))$ , δηλαδή, αν  $pn = O(\text{poly}(\ln n))$ , για το τυχαίο  $G(n, p)$  δίκτυο και *quasipolynomial* για μέσους βαθμούς μέχρι  $o(n)$ . Όσον αφορά το συνολικό ποσό κυκλοφορίας, οι περισσότερες εργασίες εγωιστικής δρομολόγησης και επίλυσης προβλημάτων σχεδιασμού δικτύων με εγωιστικούς χρήστες υποθέτουν ότι  $r = 1$ , ή τουλάχιστον ότι το  $r$  δεν αυξάνει με το μέγεθος του δικτύου (βλ. π.χ., στο [76], και τις αναφορές εκεί). Έτσι πορούμε και προσεγγίζουμε σε πολυωνυμικό χρόνο, το καλύτερο υποδίκτυο για μια μεγάλη κατηγορία περιπτώσεων που, με μεγάλη πιθανότητα, περιλαμβάνουν εκθετικά πολλά  $s - t$  μονοπάτια και μονοπάτια μήκους  $\Theta(n)$ . Για τέτοιες περιπτώσεις, μια άμεση εφαρμογή του [[42], θεώρημα 3] δίνει έναν αλγόριθμο εκθετικού χρόνου.

Η κεντρική ιδέα πίσω από την προσέγγισή μας, και η κύρια τεχνική μας

συνεισφορά μας, είναι μια πολυωνυμικού χρόνου αναγωγή του προβλήματος σε ένα καλό στιγμύτυπο  $G$  σε πρόβλημα σε ένα απλουστευμένο δίκτυο  $G_0$ , το οποίο είναι ένα *layered* δίκτυο που προκύπτει αν κρατήσουμε από τον  $G$  μόνο τον  $s$ , τον  $t$  και τους τους άμεσους γείτονες τους, και συνδέσουμε όλους τους γείτονες του  $s$  και του  $t$  με μηδενικού κόστους ακμές. Πρώτα δείχνουμε ότι το κόστος της ισορροπίας στο καλύτερο υποδίκτυο δεν αυξάνεται όταν θεωρούμε το απλοποιημένα  $G_0$  (λήμμα 5.2). Αν και αυτό μπορεί να ακούγεται λογικό, τονίζουμε ότι μικραίνοντας σε 0 το κόστος μιας ακμής μπορεί να προκαλέσουμε παράδοξο του Βραεσ (π.χ., ξεκινώντας από το δίκτυο στην Εικ. 8.2.α με  $d(v, w)(x) = 1$ , και τη μείωση στην  $d(v, w)(x) = 0$  είναι ένας άλλος τρόπος προκλήσης του παράδοξου). Η σημασία του απλοποιημένου δικτύου είναι ότι σε μεγάλο βαθμό απλοποιεί το πρόβλημα εύρεσης καλύτερου υποδικτύου, δεδομένου ότι μας επιτρέπει να επικεντρωθούμε στο φόρτωμα των ακμών των  $s$  και  $t$ . Σε έντονη αντίθεση, το αντίστοιχο υποδίκτυα σε [[84], Εικ. 36], [[25], Εν. 2.3 Εικ. 2], εκθέτουν το παράδοξο: εφαρμόζουν τα όρια του *Chernoff* για να δείξουν ότι υπάρχουν κατάλληλα μέρη του δικτύου στα οποία μπορεί να δρομολογηθεί ακόμη περισσότερη ροή μέσα από αυτά χωρίς να αυξηθεί το κόστος. Το παράδοξο έρχεται σαν αποτέλεσμα μιας διαισθητικά σωστής, έξυπνης παρατήρησης [49, 59]: η κοινή καθυστέρηση στην ισορροπία αυστηρά αυξάνεται με την συνολική ροή  $r$ . Προσεγγίζουμε το καλύτερο υποδίκτυο (θεώρημα 5.7) μέσω του απλοποιημένου δικτύου  $G_0$  χρησιμοποιώντας μια προσεγγιστική εκδοχή του θεώρηματος του Καραθεοδωρή (θεώρημα 5.6).

Το τελικό (και κρίσιμο) βήμα μας της προσέγγισης, είναι να ξεκινήσουμε με τη λύση στο απλοποιημένα δίκτυο, και να επεκταθούμε σε μια λύση στο αρχικό (καλό) στιγμύτυπο. Προς τούτο, δείχνουμε πώς μπορεί κάποιος να 'προσομοιώσει' τις μηδενικού κόστους ακμές στο ενδιαμέσο του δικτύου, με μονοπάτια πολύ χαμηλού κόστους στο αρχικό καλό στιγμύτυπο δικτύου. Διαισθητικά, αυτό λειτουργεί, λόγω των ιδιοτήτων επεκτατικότητας και των (τυχαίων) συναρτήσεων του καλού δικτύου  $G$ , για το ενδιαμέσο υποδίκτυο, που συνδέει γείτονες του  $s$  με τους γείτονες του  $t$ . Ουσιαστικά το εσωτερικό του  $G$  συμπεριφέρεται ως ένα πλήρες διμερές γράφημα με ακμές μηδενικού κόστους. Αυτό είναι επίσης το βασικό βήμα για την προσέγγιση των [24, 84], δείχνουν ότι το παράδοξο του Βραεσ εμφανίζεται σε καλή δίκτυα με υψηλή πιθανότητα (δείτε [[84], ενότητα 2]). Ως εκ τούτου, θα μπορούσε κανείς να υποστηρίξει ότι σε κάποιο βαθμό, ο λόγος για τον οποίο το παράδοξο του *Braess* υπάρχει σε καλά δίκτυα είναι ο ίδιος λόγος που το παράδοξο μπορεί αποτελεσματικά εκδιωχθεί. Αν και εννοιολογικά απλή, η πλήρης κατασκευή εμπλέκεται τεχνικά και απαιτεί πλήρη ενασχόληση με τις ροές στις ακμές των  $s$  και  $t$  και των γειτόνων τους. Η κατασκευή μας χρησιμοποιεί ένα προσεκτικό επιχείρημα ομαδοποίησης-ταιριάσματος, που με μεγάλη πιθανότητα δουλεύει καλά για καλά στιγμύτυπα, δείτε λήμματα 5.8 και 5.9.

Τονίζουμε ότι η αναγωγή η ίδια τρέχει σε πολυωνυμικό χρόνο. Το χρονοβόρο βήμα είναι η εύρεση μιας (προσεγγιστικής) λύσης στο απλοποιημένο δίκτυο. Δεδομένου ότι τα δίκτυα αυτά έχουν μόνο πολυωνυμικά πολλά (και πολύ σύντομα)  $s - t$  μονοπάτια, ξεφεύγουν από τα αποτελέσματα δυσκολίας του [78]. Το *approximability* του καλύτερου υποδικτύου για τα απλοποιημένα δίκτυα είναι ένα ενδιαφέρων ανοιχτό πρόβλημα που απορρέει από την εργασία μας και που συζητάμε στην ενότητα 15.1.

Το αποτέλεσμα μας δείχνει ότι ένα πρόβλημα, που είναι *NP* δύσκολο να το προσεγγίσεις, μπορεί να προσεγγιστεί πολύ στενά σε τυχαία (και *randomlike*) δίκτυα. Αυτό μοιάζει με π.χ., το πρόβλημα της εξεύρεσης μια Χαμιλτονιανής διαδρομής σε *Erdos Renyi* γραφήματα, όπου και πάλι, η ύπαρξη και η κατασκευή δουλεύουν και πάλι ακριβώς πάνω από το όριο της συνδεσιμότητας, δείτε π.χ., [15]. Ωστόσο, δεν είναι όλα τα προβλήματα εύκολα αν κάποιος θεωρήσει τυχαίες τις εισόδους (π.χ., το *factoring* ή το πρόβλημα κρυμμένης κλίκα, που δεν είναι γνωστά σε πλήρες βάθος).

## 2.3 Στοχαστικά Παίγνια Συμφοράσης

Εστιάζουμε την προσοχή μας στα ατομικό παίγνια συμφοράσης, και εισάγουμε δύο εκδοχές των στοχαστικών παιγνίων συμφοράσης, που εμπνέονται από τις κύριες πηγές αβεβαιότητας στις καθυστερήσεις των δικτύων μεταφορών και των τηλεπικοινωνιακών δικτύων. Ξεκινάμε από την παρατήρηση ότι η μεταβλητότητα στις καθυστερήσεις των ακμών προέρχεται είτε από τη μεταβλητότητα στην ζήτηση, και την επακόλουθη μεταβλητότητα στο φορτίο της ακμής, ή από το μεταβλητότητα της απόδοσης της ακμής. Αποσύνδεοντάς τες, εισάγουμε δυο ειδών στοχαστικά παίγνια συμφοράσης, που είναι τα *παίγνια συμφοράσης με στοχαστικούς παίκτες* και τα *παίγνια συμφοράσης με στοχαστικές σκμές*, που αντίστοιχα συλλαμβάνουν της περιπτώσεις αβεβαιότητας που αναφέρονται παραπάνω. Για το αρχικό έργο βλ. [6]. Το σχήμα 2.3 τοποθετεί τα μοντέλα μας στον χάρτη των παιγνίων συμφοράσης.

Τα παίγνια συμφοράσης με στοχαστικούς παίκτες στοχεύουν να πιάσουν τη μεταβλητότητα στην ζήτηση των ακμών. Συγκεκριμένα, κάθε παίκτης  $i$  συμμετέχει στο παιχνίδι, στην πραγματικότητα, διατρέχει το μονοπάτι του, ανεξάρτητα, με πιθανότητα  $p_i$ . Ως αποτέλεσμα, το συνολικό φορτίο του δικτύου και τα φορτία των ακμών και κατά συνέπεια τα κόστη τους είναι τυχαίες μεταβλητές. Από την άλλη πλευρά, τα παίγνια με στοχαστικές ακμές αποσκοπούν να πιάσουν την μεταβλητότητα της λειτουργικότητας του δικτύου. Τώρα, κάθε ακμή  $e$  μπορεί να λειτουργεί είτε στην 'τυπική' λειτουργία, όπου η καθυστέρηση δίνεται από μια συνάρτηση  $f_e(x)$ , ή στην 'ελλατωματική' λειτουργία, όπου η καθυστέρηση δίνεται από μια συνάρτηση  $g_e(x)$ , όπου  $g_e(x) \geq f_e(x)$

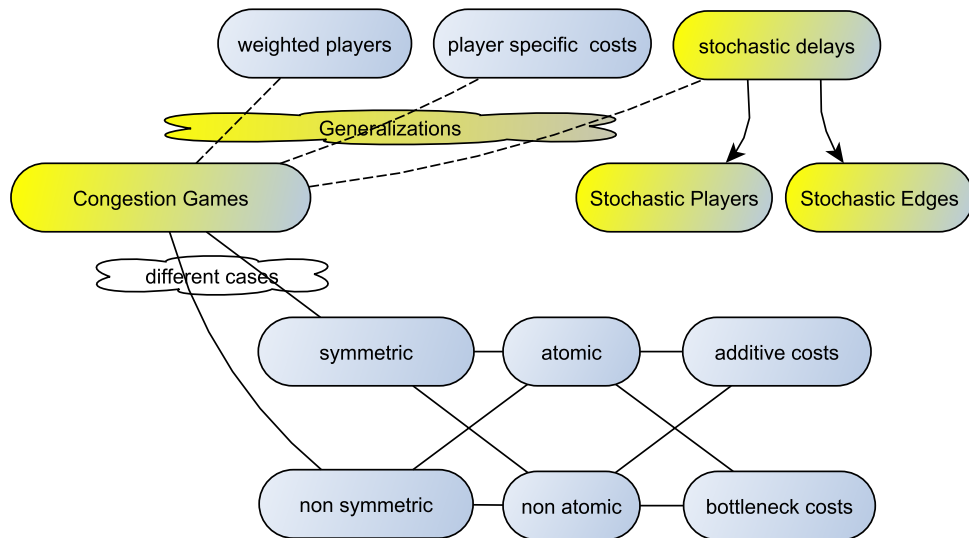

**Σχήμα 2.3:** Τα εισηγμένα μοντέλα και η τοποθέτησή τους στο Χάρτη.

για κάθε  $x \geq 0$  (π.χ., μια ακμή λειτουργεί στην 'ελαττωματική' λειτουργία μετά από ένα μικρό ατύχημα ή μια αποτυχία σύνδεσης). Κάθε ακμή  $e$  συμπεριφέρεται στην 'τυπική' λειτουργία ανεξάρτητα με μια δεδομένη πιθανότητα  $p_e$ . Ως εκ τούτου, το φορτίο του δικτύου και τα φορτία των ακμών τώρα είναι νιτερμινιστικά, αλλά οι ακμές και οι καθυστερήσεις στα μονοπάτια είναι τυχαίες μεταβλητές. Και στις δύο παραλλαγές, υποθέτουμε ότι οι παίκτες να έχουν κάποιο φόβο απέναντι στο ρίσκο που προσδίδουν οι στοχαστικές καθυστερήσεις. Συγκεκριμένα, κάθε παίκτης  $i$  έχει ένα (πιθανώς διαφορετικό) επίπεδο σιγουριάς  $\delta_i$ , και το ατομικό του κόστος για ένα μονοπάτι  $q$  θεωρείται ότι είναι το  $\delta_i$ -χουαντιλε (γνωστός και ως *value-at-risk*) της κατανομής της καθυστέρησης του μονοπατιού  $q$ . Με απλά λόγια, το επιμέρους κόστος του παίκτη  $i$  είναι η ελάχιστη καθυστέρηση που μπορεί να νιώσει κατά μήκος του  $q$  με πιθανότητα τουλάχιστον  $\delta_i$ .

Στο εννοιολογικό επίπεδο, το μοντέλο των παιγνίων συμφόρησης με στοχαστικούς παίκτες είναι παρόμοιο με το μοντέλο με ενδογενή τυπικές αποκλίσεις των [67]. Στην πραγματικότητα, χρησιμοποιώντας τα όρια του *Chernoff*, μπορούμε να δείξουμε ότι για γραμμικές συναρτήσεις, εάν το αναμενόμενο φορτίο σε κάθε ακμή δεν είναι πολύ μικρό, τα  $\delta_i$ -*quantile* κόστη μπορούν να προσεγγισθούν με τις συναρτήσεις κόστους που χρησιμοποιούν στο [67]. Ωστόσο, θεωρούμε στοχαστικές απαιτήσεις, μια κατεύθυνση που προτείνεται και στο [67, Ενот. 7], και παίκτες που είναι ετερογενής όσον αφορά τη στάση τους απέναντι στο ρίσκο. Όσο για τα παίγνια συμφόρησης με στοχαστικές ακμές, το μοντέλο είναι εννοιολογικά παρόμοιο με το μοντέλο με εξωγενείς



τυπικές αποκλίσεις των [67].

Στο τεχνικό μέρος, περιοριζόμαστε στη σημαντική ειδική περίπτωση δικτύων παραλλήλων ακμών με συμμετρικές στρατηγικές, και διερευνούμε πώς οι ιδιότητες των στοχαστικών παιγνίων συμφοράς εξαρτώνται από το αν οι παίκτες έχουν τις ίδιες πιθανότητες συμμετοχής ή/και επιπέδου σιγουριάς ή όχι. Αρχικά, παρατηρούμε ότι τέτοια παιχνίδια επιδέχονται μια συνάρτηση δυναμικού και ένα αποδοτικό υπολογισμό *PNE*, αν οι παίκτες είναι ομοιογενείς, δηλαδή εάν έχουν το ίδιο επίπεδο σιγουριάς  $\delta$  και, στην περίπτωση με στοχαστικούς παίκτες, την ίδια συμμετοχή πιθανότητα  $p$  (θεωρήματα 6.1 και 6.8). Επίσης δείχνουμε ότι, αν οι παίκτες έχουν διαφορετικά επίπεδα σιγουριάς (και την ίδια πιθανότητα συμμετοχής, αν πρόκειται για στοχαστικούς παίκτες), τα στοχαστικά παίγνια συμφοράς ανήκουν στην κατηγορία των παιγνίων συμφοράς με παικτοεξαρτώμενες συναρτήσεις ([63]), και κατά συνέπεια η ύπαρξη *PNE* υπολογίζεται σε πολυωνυμικό χρόνο (πορίσματα 6.2 και 6.9). Στην αρνητική πλευρά, μπορούμε να αποδείξουμε ότι τέτοια παίγνια δεν δέχονται συνάρτηση δυναμικού (θεωρήματα 6.3 και 6.10). Για παίγνια συμφοράς με στοχαστικούς παίκτες που έχουν το ίδιο επίπεδο σιγουριάς και διαφορετικές πιθανότητες συμμετοχής, ποδεικνύουμε ότι επιδέχονται μια λεξικογραφική συνάρτηση δυναμικού (θεώρημα 6.5), και έτσι και μια *PNE*, και επίσης ότι μια *PNE* μπορεί να υπολογιστεί από ένα απλό άπληστο αλγόριθμο (θεώρημα 6.4), όπου οι παίκτες διαδοχικά διαλέγουν την καλύτερη στρατηγική ανταπόκρισης σε μη-φθίνουσα σειρά πιθανοτήτων συμμετοχής, λαμβάνοντας υπόψη τις στρατηγικές των παικτών που προηγούνται στη σειρά. Όσο για την υποβάθμιση του δικτύου στην *PNE*, εστιάζοντας σε δίκτυα παραλλήλων ακμών με αφινικές συναρτήσεις, αποδεικνύουμε ότι το κόστος της αναρχίας (PoA) είναι  $\Theta(n)$ , όπου  $n$  είναι ο αριθμός των παικτών, στην περίπτωση των στοχαστικών παικτών (θεωρήματα 7.3 και 6.7), και μπορεί να είναι μη φραγμένη, στην περίπτωση των στοχαστικών ακμών (θεώρημα 6.11).

## 2.4 Βελτιώνοντας την Απόδοση του Δικτύου Εκμεταλλευόμενοι τον Φόβο των Παικτών

Με κίνητρο τα αποτελέσματα του [71], θεωρούμε (μη ατομικά) παίγνια συμφοράς με παίκτες ευαίσθητους στο ρίσκο και διερευνούμε πώς μπορεί κάποιος να εκμεταλλευτεί την αποστροφή των παικτών στον κίνδυνο ώστε να μεταβάλλει το αντιλαμβανόμενο από τους παίκτες κόστος έτσι ώστε το (αναμενόμενο) PoA για τις πραγματικές συναρτήσεις κόστους να βελτιώνεται σημαντικά. Εξ όσων γνωρίζουμε, αυτή είναι η πρώτη φορά που η αποστροφή απέναντι στο ρίσκο προτείνεται ως ‘θεραπεία’ στην υποβάθμιση του δικτύου

λόγω της εγωιστική συμπεριφοράς των παικτών.

Αφειρηρία μας είναι ότι σε ορισμένες πρακτικές εφαρμογές, μπορεί να εισάγουμε προσεκτικά εξωγενή διακύμανση στις καθυστερήσεις των ακμών έτσι ώστε η αναμενόμενη καθυστέρηση να μην αλλάζει, αλλά το κόστος που υπολογίζουν οι πείκτες λόγω του φόβου τους απέναντι στο ρίσκο να αλλάζει. Για παράδειγμα, σε ένα συγκοινωνιακό δίκτυο, αυτό μπορεί να γίνει αυξάνοντας ή μειώνοντας τυχαία το ποσοστό του χρόνου που διατίθεται για το πράσινο φανάρι ή ανοίγοντας ή κλείνοντας μια βοηθητική λωρίδα κυκλοφορίας. Σε ένα δίκτυο τηλεπικοινωνιών, μπορούμε με τυχαίο τρόπο να αυξάνουμε ή να μειώνουμε την ικανότητα των συνδέσεων που διατίθενται ή να αλλάζουμε την προτεραιότητα μεταξύ τους. Έτσι, υποθέτουμε ότι για κάθε ακμή  $e$ , μπορούμε να αυξήσουμε (κατά ένα μικρό πολλαπλασιαστικό συντελεστή) την καθυστέρηση της  $e$  με κάποια θετική πιθανότητα  $p_e$  και να την μειώσουμε με κάποια θετική πιθανότητα  $q_e$ , όπου τα  $p_e$  και  $q_e$  είναι συνήθως μικρές, έτσι ώστε η αναμενόμενη καθυστέρηση στην  $e$  να παραμένει  $d_e(x)$ . Από την άλλη πλευρά, η διακύμανση της καθυστέρησης που εισάγαμε με αυτές τις τυχαίες αλλαγές αυξάνει το θεωρούμενο από τους παίκτες κόστος. Ως εκ τούτου, προσαρμόζοντας προσεκτικά το αντιληπτό κόστος από τους παίκτες, μπορούμε να ελέγξουμε την συμφοράση του δικτύου, με έναν τρόπο που είναι εννοιολογικά παρόμοιος με εκείνο των φόρων ή των διοδίων, και να βελτιώσουμε το ΡοΑ μέσα από έναν εκλεπτισμένο και εύκολο να εφαρμοστεί μηχανισμό ο οποίος εκμεταλλεύεται την αποστροφή των παικτών στο ρίσκο.

Πιο συγκεκριμένα, υποθέτουμε ότι όλοι οι παίκτες έχουν ομοιογενή συμπεριφορά απέναντι στον κίνδυνο και ότι οι τυχαίες αλλαγές στο αντιληπτό κόστος των παικτών είναι ένας τον πολλαπλασιαστικός συντελεστή (συνήθως μικρός) του κόστους της ακμής. Στην πραγματικότητα, μπορούμε να υποθέσουμε ότι η αντιληπτή συνάρτηση καθυστέρησης κάθε άκμης  $e$  μπορεί να αλλάξει από  $d_e(x)$  σε  $(1 + \gamma_e)d_e(x)$ , όπου το  $\gamma_e > 0$  μπορεί να εξαρτάται από την ακμή, τον τύπο και την πιθανότητα τυχαίων αλλαγών, τη στάση των παικτών απέναντι στο ρίσκο, το ακριβή τύπος του κόστους των παικτών, και το σημαντικότερο, από το εκάστοτε μοντέλο. Παρά το γεγονός ότι συζητούμε εν συντομία, στην ενότητα 14.1 πώς καθορίζεται το  $\gamma_e$  και παρέχουμε και μερικά παραδείγματα, για διατήρηση της απλότητας και της γενικότητας, σκόπιμα αποφεύγουμε να μπούμε σε λεπτομέρειες για το πώς υπολογίζονται τα  $\gamma_e$ 'ς. Αντίθετα, εμείς απλά θεωρούμε ένα δεδομένο άνω όριο για την μεγαλύτερη τιμή του  $\gamma$  στις συναρτήσεις καθυστέρησης και αναφεόμαστε στο αντίστοιχο παίγνιο συμφοράσης ως  $\gamma$  - *modifiable* παίγνιο (ή σιγμυότυπο), κατανοώντας ότι σε κάθε περίπτωση το  $\gamma$  μπορεί να καθοριστεί λαμβάνοντας υπόψη όλους τους παράγοντες που αναφέρονται παραπάνω. Με αυτούς τους ορισμούς, μια ροή (και συγκεκριμένα, η βέλτιστη ροή, η οποία ελαχιστοποιεί το συνολικό αναμενόμενο πραγματικό κόστος των παικτών) είναι

$\gamma$  – *enforceable* (ή απλά, *enforceable*) εαν πρόκειται για μια ροή  $N$  στο παραλλαγμένο παίγνιο με την αντιληπτή συνάρτηση κόστους κάθε ακμής  $e$  να είναι ίση με  $(1 + \gamma_e)d_e(x)$ , για κάποια  $\gamma_e \in [0, \gamma]$ .

Από τεχνικής πλευράς, παρατηρούμε ότι η μέγιστη αναλογία του *marginal cost toll* προς την καθυστέρηση στην βέλτιστη λύση για μια ακμή δίνει ένα άνω όριο για την τιμή των  $\gamma$  που απαιτείται για να γίνει ισορροπία η βέλτιστη ροή του δικτύου (πρόταση 8). Αυτό καθιερώνει τη δυνατότητα εφαρμογής της προσέγγισής μας και τυποποιεί την σύνδεσή της με τα επιστρεφόμενα διόδια. Ωστόσο, εκτός από το γεγονός ότι χρησιμοποιούμε πολλαπλασιαστικές τροποποιήσεις, μια σημαντική διαφορά της προσέγγισής μας από από τα διόδια είναι ότι πάντα υποθέτουμε ένα άνω όριο  $\gamma$  για την αλλαγή της αντιληπτής από τους παίκτες συνάρτησης για κάθε ακμή, ενώ τα βέλτιστα διόδια μπορεί να γίνουν αυθαίρετα μεγάλα, π.χ., τόσο μεγάλο όσο η καθυστέρηση στην πιο αργό  $s - t$  μονοπάτι που χρησιμοποιείται από τη βέλτιστη ροή (βλ. π.χ., [35, Θεώρημα 4.1]).

Στη συνέχεια, για να αποδείξουμε την αποτελεσματικότητα της προσέγγισής μας, εστιάζουμε στην απλή και σημαντική ειδική περίπτωση των δικτύων παραλλήλων ακμών (ενότ. 7.2). Χαρακτηρίζουμε την κατηγορία των  $\gamma$  – *modifiable* παιγνίων συμφόρησης σε δίκτυα παραλλήλων ακμών για τα οποία η βέλτιστη ροή είναι εφικτό να γίνει ροή ισορροπίας στο τροποποιημένο δίκτυο (θεώρημα 7.1). Με βάση αυτό το χαρακτηρισμό, παρουσιάζουμε μια αναδρομική διαδικασία που δεδομένου ενός  $\gamma$  – *modifiable* παίγνιου συμφόρησης και της βέλτιστη ροής, υπολογίζει ένα σύνολο  $\gamma$  – *bounded* μεταβολών στις συναρτήσεις με κάτω από τις οποίες το PoA είναι σημαντικά λιγότερο από το PoA του αρχικού παίγνιου (λήμμα 7.2). Γενικεύοντας την προσέγγιση με *variational inequality* του [29], μπορούμε να αποδείξουμε ότι το PoA της καλύτερης ροής που μπορεί να προκύψει είναι  $\max\{1, (1 - \beta_\gamma(\mathcal{D}))^{-1}\}$ , όπου  $\mathcal{D}$  είναι η κλάση των συναρτήσεων καθυστέρησης του παίγνιου και

$$\beta_\gamma(\mathcal{D}) = \sup_{d \in \mathcal{D}, x \geq y \geq 0} \frac{y(d(x) - d(y)) - \gamma(x - y)d(x)}{xd(x)}$$

είναι μια φυσική γενίκευση της ποσότητας  $\beta(\mathcal{D})$  του [29] (θεώρημα 7.3). Για παράδειγμα, από την ανάλυση μας συνεπάγεται ότι για γραμμικές καθυστερήσεις, το PoA της καλύτερης  $\gamma$  – *enforceable* ροής υπολογισμένης με τη δική μας προσέγγιση είναι το πολύ  $\max\{1, (1 - (1 - \gamma)^2/4)^{-1}\}$  (πόρισμα 7.5), που είναι σημαντικά λιγότερο από το  $4/3$ , ακόμα και για μικρές τιμές του  $\gamma$  (π.χ., είναι λιγότερο από  $6/5$  για  $\gamma = 0, 1$ ). Επίσης δείχνουμε ότι η PoA ανάλυση όσον αφορά την  $\gamma$  είναι σφιχτή (θεώρημα 7.7). Τέλος, δίνουμε μια διαδικασία που υπολογίζει ένα σύνολο  $\gamma$  – *bounded* μεταβολών των συναρτήσεων καθυστέρησης και την αντίστοιχη  $\gamma$  – *enforceable* ροή με τέτοιο PoA η οποία τρέχει σε χρόνο πολυωνυμικά σχετιζόμενο με το χρόνο

που απαιτείται για τον υπολογισμό *Nash* ροών σε δίκτυα παραλλήλων ακμών (λήμμα 7.8). Ως εκ τούτου, δεδομένου οποιοδήποτε  $\gamma$  – *modifiable* παίγνιου σε δίκτυο παραλλήλων ακμών, μπορούμε αποτελεσματικά (για μια ευρεία κατηγορία συναρτήσεων) να υπολογίζουμε ένα παίγνιο με τις αντιληπτές συναρτήσεις αλλαγμένες το πολύ κατά ένα παράγοντα  $1 + \gamma$ , έτσι ώστε το PoA είναι το πολύ  $\max\{1, (1 - \beta_\gamma(\mathcal{D}))^{-1}\}$ .

Στην ενότητα 7.3 συζητάμε την συσχέτιση των  $\gamma$  – *modifiable* παιγνίων συμφόρησης με τα παίγνια συμφόρησης με περιορισμένα διόδια (ή φόρους) ([17]). Επισημαίνουμε τα αποτελέσματα του [17] που μπορούν να εφαρμοστούν στα  $\gamma$  – *modifiable* παίγνια συμφόρησης ενώ υποστηρίζουμε την κατασκευαστική και πιο περίπλοκη προσέγγισή μας καθώς μας δίνει καλύτερη εικόνα για το πρόβλημα της εξεύρεσης βέλτιστων  $\gamma$  – *modifications* και για την βελτίωση του τιμήματος της αναρχίας.

Στην ενότητα 7.4, συζητάμε πώς η προσέγγιση μπορεί να επεκταθεί σε πιο γενικά πλαίσια. Πρώτα, δίνουμε τη διαίσθηση του πώς παρόμοιες τεχνικές με αυτές για τα δίκτυα παράλληλων ακμών μπορούν να χρησιμοποιηθούν για την περίπτωση σειριακών-παράλληλων δικτύων. Δεδομένου ότι έχουμε ολοκληρώσει τις αποδείξεις πολύ πρόσφατα, επιλέξαμε να μην υπερλάβουμε αυτά τα αποτελέσματα στην παρούσα διατριβή. Αντ' αυτού, εξηγούμε την προσέγγιση που χρειάζεται να κάνουμε παρέχοντας τις κεντρικές ιδέες. Αμέσως μετά συζητάμε πώς μπορούμε να καταλήξουμε σε παρόμοια αποτελέσματα για την περίπτωση δικτύων παραλλήλων ακμών με ετερογενείς παίκτες και γενικότερους περιορισμούς σχετικά με την αβεβαιότητα που επιτρέπεται να προστεθεί στις ακμές. Σημειώστε εδώ ότι αυτή την περίπτωση δεν έχει λυθεί από κανένα από τα [51], [17] και [53], που ασχολούνται με παίγνια συμφόρησης με φραγμένα διόδια-φόρους.

## Κεφάλαιο 3

### Προκαταρκτικές Έννοιες

In this chapter we state basic definitions needed in the following chapters. Model specific definitions and properties are given separately at the beginning of each chapter.

#### 3.1 Γενικοί Όροι και Συμβάσεις

For a random variable  $X$ ,  $\mathbf{E}[X]$  denotes the **expectation** of  $X$  and  $\mathbf{Var}[X]$  denote the *variance* of  $X$ . For an event  $E$  in a sample space,  $\mathbf{Pr}[E]$  denotes the probability of  $E$  happening. We say that an event  $E$  occurs **with high probability**, if there is a constant  $a \geq 1$ , such that  $\mathbf{Pr}[E] \geq 1 - n^{-a}$ , where  $n$  usually denotes the number of vertices of the network  $G$  to which  $E$  refers. We implicitly use the union bound to account for the occurrence of more than one low probability events.

For any integer  $n \geq 1$ , we let  $[n] = \{1, \dots, n\}$

A latency function  $c_e(x)$  is **linear** if  $c_e(x) = a_e x$ , for some  $a_e > 0$ , and **affine** if  $c_e(x) = a_e x + b_e$ , for some  $a_e, b_e \geq 0$ . We say that a latency function  $c_e(x)$  satisfies the **Lipschitz condition** with constant  $\xi > 0$ , if for all  $x, y \in [0, r]$ ,  $|c_e(x) - c_e(y)| \leq \xi|x - y|$ .

#### 3.2 Ορισμοί Παιγνίων Συμφόρησης

An **atomic Congestion Game** is a tuple  $\mathcal{G}(N, E, (S_i)_{i \in N}, (d_e)_{e \in E})$ , where  $N$  denotes the set of players,  $E$  denotes the set of resources,  $S_i \subseteq 2^E \setminus \{\emptyset\}$  denotes the strategy space of each player  $i$  and  $d_e : \mathbb{N} \mapsto \mathbb{R}_{\geq 0}$  is a non-negative and non-decreasing latency function associated with each resource  $e$ .

Network Congestion Games are CGs in which players have a source node,  $s_i$ , and a target node,  $t_i$ , on a directed graph (network) and the strategy space of each player  $i$  is consisted by the paths that connect  $s_i$  with  $t_i$ . The resources of the CG are exactly the edges of the network each of which comes together with a latency (cost) function.

An **atomic Network CG** is a tuple  $\mathcal{G}(G(V, E), (d_e)_{e \in E}, K, \{N\}_{i=1 \dots |K|})$ , where  $G = (V, E)$  denotes a directed network,  $K \subseteq V \times V$  is a set of  $s_i - t_i$  source target pairs,  $d_e : \mathbb{R}_{\geq 0} \mapsto \mathbb{R}_{\geq 0}$  is a non-negative and non-decreasing latency function associated with each edge  $e$  and  $N = (n_1, \dots, n_{|K|})$  is the vector of players, where  $n_i$  is the number of players that must move from source  $s_i$  to target  $t_i$ .

Non atomic network CGs are like atomic network CGs with infinite, infinitesimal players, i.e. the presence or the absence of a player on a resource does not affect the congestion on the resource. The infinite players that share the same  $s_i - t_i$  pair form an amount of flow that must be routed from  $s_i$  to  $t_i$ .

A **non atomic Network CG** is a tuple  $\mathcal{G}(G(V, E), (d_e)_{e \in E}, K, r)$ , where  $G = (V, E)$  denotes a directed network,  $K \subseteq V \times V$  is a set of  $s_i - t_i$  source target pairs,  $d_e : \mathbb{R}_{\geq 0} \mapsto \mathbb{R}_{\geq 0}$  is a non-negative and non-decreasing latency function associated with each edge  $e$  and  $r = (r_1, \dots, r_{|K|})$  is a vector of flows that must be routed, where  $r_i$  is the amount of flow that must be routed from source  $i$  to target  $i$ .

Network CGs are also referred as **Selfish Routing Games**. In a CG, if all players share the same strategy space then we have a *symmetric* CG. We deal with symmetric network CGs case where  $K$  contains a single  $s - t$  pair and thus, assuming that  $s$  and  $t$  are specified in  $G$ , we use the terminology  $\mathcal{G}(G(V, E), (d_e)_{e \in E}, n)$  for atomic network CGs, where  $n$  is the number of players that use the network, and  $\mathcal{G}(G(V, E), (d_e)_{e \in E}, r)$  for non atomic network CGs, where  $r$  is an amount of flow to be routed in the network. We let  $\mathcal{P}$  be the set of paths connecting  $s$  to  $t$ . We may also use  $\mathcal{G}(G(V, E), n)$  or  $\mathcal{G}(G(V, E), r)$  respectively if the set of latency functions under use is clear from the context or is assumed to be given within the network  $G$ .

**Subnetworks and Subinstances.** Given an instance  $\mathcal{G} = (G(V, E), (d_e)_{e \in E}, x)$ , any subgraph  $H(V, E')$ ,  $E' \subseteq E$ , obtained from  $G$  by edge deletions, is a *subnetwork* of  $G$ .  $H$  has the same origin  $s$  and destination  $t$  as  $G$ , and the edges of  $H$  have the same latency functions as in  $\mathcal{G}$ . Each instance  $\mathcal{H} = (H(V, E'), (d_e)_{e \in E'}, x)$ , where  $H(V, E')$  is a subnetwork of  $G(V, E)$ , is a *subinstance* of  $\mathcal{G}$ .

In atomic CGs, a **configuration** is a vector  $s = (s_1, \dots, s_n)$  consisting of

a strategy  $s_i \in S_i$  for each player  $i$ . We let  $s_e = \{|i : e \in s_i|\}$  denote the congestion induced on each resource  $e$  by  $s$ .

In non atomic network CGs, a (feasible) **flow**  $f$  is a non-negative vector indexed by  $\mathcal{P}$  so that  $\sum_{p \in \mathcal{P}} f_p = r$ . For a flow  $f$  and each edge  $e$ , we let  $f_e = \sum_{p: e \in p} f_p$  denote the amount of flow that  $f$  routes through  $e$ . An edge  $e$  is used by flow  $f$  if  $f_e > 0$ . A path  $p$  is used by flow  $f$  if all its edges are used, i.e.  $\min_{e \in p} \{f_e\} > 0$ . Somehow abusing notation, if  $p$  is used we may write  $f_p > 0$ .

**Additive Costs.** In additive costs atomic CGs, the cost of the strategy  $s_i$  of player  $i$  under configuration  $s$  is  $d_i(s) = \sum_{e \in s_i} d_e(s_e)$ . Similar, for additive costs non atomic network CGs, the cost of a path  $p$  under flow  $f$  is  $d_p(f) = \sum_{e \in p} d_e(s_e)$

**Bottleneck Costs.** In bottleneck costs atomic CGs, the cost of the strategy  $s_i$  of player  $i$  under configuration  $s$  is  $b_i(s) = \max_{e \in s_i} d_e(s_e)$ . Similar, for bottleneck costs non atomic network CGs, the cost of a path  $p$  under flow  $f$  is  $b_p(f) = \max_{e \in p} d_e(s_e)$ .

### 3.3 Ισορροπίες

There are different ways to define an equilibrium. We are concerned in the case of *Pure Nash Equilibrium*. Informally, a configuration  $s$  or a flow  $f$  is a *Pure Nash equilibrium* if no player can improve her individual cost by unilaterally changing her strategy.

**Pure Nash Equilibrium - Nash flows.** For an atomic additive costs CG, a configuration  $s$  is said to be a Pure Nash Equilibrium (PNE) if  $d_i(s_i, s_{-i}) \leq d_i(s'_i, s_{-i}), \forall s'_i \in S_i$ , where  $d_i(k, s_{-i})$  denotes the cost of player  $i$  for the configuration where  $i$  plays strategy  $k$  and the rest of the players play according to configuration  $s$ . For a non atomic additive costs network CG,  $f$  is a Nash Equilibrium or a Nash flow if for all  $s-t$  paths  $p, p'$ , if  $f_p > 0$ , then  $d_p(f) \leq d_{p'}(f)$ .

Similar, for an atomic bottleneck costs CG, a configuration  $s$  is said to be a Pure Nash Equilibrium if  $b_i(s_i, s_{-i}) \leq b_i(s'_i, s_{-i}), \forall s'_i \in S_i$ , where  $b_i(k, s_{-i})$  denotes the cost of player  $i$  for the configuration where  $i$  plays strategy  $k$  and the rest of the players play according to configuration  $s$ . For a non atomic bottleneck costs network CG,  $f$  is a Nash Equilibrium or a Nash flow if for all  $s-t$  paths  $p, p'$ , if  $f_p > 0$ , then  $b_p(f) \leq b_{p'}(f)$ . A basic property of non atomic network CGs is that all players incur the same latency either under additive or under bottleneck costs.

**$\varepsilon$ -Nash Equilibria (Flows).** The definition of a Nash Equilibrium can be

generalized to that of an “almost Nash” Equilibrium: For some constant  $\varepsilon > 0$ , a configuration or flow  $x$  is an  $\varepsilon$ -Nash Equilibrium if for all  $s - t$  paths  $p, p'$ , if  $x_p > 0$ ,  $d_p(x) \leq d_{p'}(x) + \varepsilon$ , for additive costs games and  $b_p(x) \leq b_{p'}(x) + \varepsilon$ , for bottleneck costs games.

**Potential Functions.** Games do not always possess PNE, though additive costs CGs always possess one. This can be proved via a potential function method. A function  $\Phi : S_1 \times \cdots \times S_n \mapsto \mathbb{R}_{\geq 0}$  is an *ordinal potential function* for a CG if  $d_i(s_{-i}, s'_i) - d_i(s) < 0 \Leftrightarrow \Phi(s_{-i}, s'_i) - \Phi(s) < 0$

Intuitively an ordinal potential is a function that follows the sign of change of any player's cost when she changes unilaterally. The admittance of the above type of potential is a necessary and sufficient condition for a game to have the Finite Improvement Property, i.e. every best response sequence is finite. So if letting the players, one at a time, to change their strategy to their best response then, at the end, we get a configuration that is a PNE.

A more strong kind of potential is the one encountered so far in CGs where a function tracks not only the sign but also the amount of the change. A function  $\Phi : S_1 \times \cdots \times S_n \mapsto \mathbb{R}_{\geq 0}$  is an *exact potential* for a CG if  $\Phi(s_{-i}, s'_i) - \Phi(s) = d_i(s_{-i}, s'_i) - d_i(s)$

Games that admit an exact potential are called *Potential Games*. It can be proved that additive costs CGs are isomorphic to Potential games. One direction is easy: CGs (atomic or non atomic with additive costs) always admit an exact potential:

**atomic case**

$$\Phi(s) = \sum_{e \in E} \sum_{i=1}^{s_e} d_e(i)$$

**non atomic case**

$$\Phi(s) = \sum_{e \in E} \int_0^{s_e} d_e(x) dx$$

For CGs with bottleneck costs, best response dynamics can also be used to prove the existence of (optimal) equilibrium, e.g. [11, Corollary 2], although, directly, the optimal solution (with respect to the social cost function defined in the next section) is a Nash equilibrium.

### 3.4 Τμήμα της Αναρχίας

Players' strategies choices cause an overall charge on the resources of the game that can be seen as an overall cost charging the network manager or



the players' "society". This is quantified via a *Social Cost Function*.

A **Social Cost Function**, for atomic games, is a function  $SC(s) : S_1 \times \dots \times S_n \rightarrow \mathbb{R}_{\geq 0}$ . The most popular Social Cost Function used in additive costs CGs is the sum of the players' costs (or, somehow equivalently, the average of the players' costs), i.e.  $SC(s) = \sum_i d_i(s_i)$ . For bottleneck costs games, the most used social cost function is  $SC(s) = \max_i b_i(s_i) = \max_{e: s_e > 0} d_e(s_e)$ . Similar, for non atomic network CGs it is  $SC(f) : \text{Space of Flows} \rightarrow \mathbb{R}_{\geq 0}$  and for additive costs CGs,  $SC(f) = \sum_p f_p d_p(f_p)$  while for bottleneck costs CGs,  $SC(f) = \max_{p: f_p > 0} b_p(f_p) = \max_{e: f_e > 0} d_e(s_e)$ . For ease of notation, for bottleneck CGs, we may use  $B(s)$  and  $B(f)$  instead of  $SC(s)$  and  $SC(f)$  respectively.

**Optimal Solutions.** A configuration that minimizes the social cost function is an optimum configuration called OPT. Similar, the optimal flow is defined as the flow that minimizes the social cost function. PNE are considered as the possible outcomes of the game, yet they do not necessarily minimize social cost. This causes inefficiency to the network. To capture this inefficiency there are two measures, one adopting a worst case approach (PoA) and the other a best case approach (PoS).

**Price of Anarchy (PoA) and Price of Stability (PoS).** By letting  $x$  denote a configuration for the case of atomic CGs and a flow for the case of non atomic CGs, define

$$PoA = \max \left\{ \frac{SC(x)}{SC(OPT)} \mid x \text{ is a PNE} \right\} \quad PoS = \min \left\{ \frac{SC(x)}{SC(OPT)} \mid x \text{ is a PNE} \right\}$$

The PoA of symmetric non atomic additive costs CGs is independent of the structure of the network as it was first shown in [74]. Correa et al. in [28] prove a general tight bound for the PoA based only on the class  $\mathcal{D}$  of latency functions, which is  $\rho(\mathcal{D}) = (1 - \beta(\mathcal{D}))^{-1}$ , where  $\beta(\mathcal{D}) = \sup_{d \in \mathcal{D}, x \geq y \geq 0} \frac{y(d(x) - d(y))}{xd(x)}$ . The same bound holds for the PoS in symmetric atomic network CGs and for the PoA on games on extension parallel networks as shown in [39]. See also e.g. [22] and [79] for similar results for atomic CGs.

For bottleneck network CGs, although the PoS is equal to 1 (see e.g. [11, Corollary 2]) the PoA behaves way much worse as simple examples give a tight bound of  $\Omega(|V|)$  (see figure 15.2 or e.g. [27, Figure 2]), where  $|V|$  is the number of vertices of the network.



## Κεφάλαιο 4

# Παράδοξο του Μπράες σε Παίγνια με Κόστη Συγκέντρωσης

Στο κεφάλαιο αυτό, διερευνούμε την υπολογιστική πολυπλοκότητα και την *approximability* του προβλήματος σχεδιασμού δικτύου για *nonatomic* παίγνια, όπου το κάθε κόστος του κάθε παίκτη είναι το κόστος της συμφόρησης του την πορεία της, και το κοινωνικό κόστος είναι το κόστος της συμφόρησης του δικτύου, δηλαδή η μέγιστη καθυστέρηση του σε μια ακμή που χρησιμοποιείται.

Πρώτα δείχνουμε ότι δυσχέρεια δρομολόγησης παιχνίδια δεν πάσχουν από το παράδοξο του *Braess* είτε αν το δίκτυο είναι *seriesparallel*, ή αν λάβουμε υπόψη μόνο *subpath optimal* ροές Nash, μια δευτερεύουσα κλάση των *Nash* ροών (τυπικά καθορισμένους στην ενότητα 6.1).

Στην αρνητική πλευρά, μπορούμε να αποδείξουμε ότι ακόμα και για παιχνίδια με αυστηρά γραμμικές συναρτήσεις καθυστέρησης, είναι NP δύσκολο όχι μόνο να αναγνωριστούν περιπτώσεις που πάσχουν από το παράδοξο, αλλά επίσης για τη διάκριση μεταξύ περιπτώσεων για τις οποίες το κόστος της αναρχίας ( $\Sigma\Delta$ ) μπορεί να μειώσει σε 1 και περιπτώσεις για τις οποίες το  $\Sigma\Delta$  δεν μπορεί να βελτιωθεί από αφαίρεση ακμών, ακόμη και αν τους  $\Sigma\Delta$  είναι τόσο μεγάλη όσο  $O(n^{0.121})$ . Αυτό σημαίνει ότι το δίκτυο πρόβλημα σχεδιασμού για γραμμική δυσχέρεια δρομολόγησης παιχνίδια είναι *NP hard* η προσέγγιση κατά έναν παράγοντα  $O(n^{0.121-\epsilon})$ , για οποιαδήποτε σταθερά  $\epsilon > 0$ . Η απόδειξη βασίζεται σε μια αναδρομικό κατασκευή σκληρό περιπτώσεις που προσεκτικά εκμεταλλεύεται τις ιδιότητες της δρομολόγησης σε τέτοια παίγνια, και μπορεί να είναι ανεξάρτητου ενδιαφέροντος.

Από τη θετική πλευρά, σας παρουσιάζουμε ένα αλγόριθμος για την εύρεση ένα υποδίκτυο που είναι σχεδόν άριστη  $\Omega PT$  της συνεργασίας το κόστος σημείο συμφόρησης του Γιαγκ χειρότερη Nash, όταν η χειρότερη ροή Nash σε το καλύτερο υποδίκτυο δρομολογεί μια *nonnegligible* ποσό της ροής στις

άκρες χρησιμοποιείται. Δείχνουμε ότι τον τρέχοντα χρόνο είναι ουσιαστικά καθορίζεται από το συνολικό αριθμό των μονοπατιών στο δίκτυο, και είναι χυασιπολψνομιαλ όταν ο αριθμός των διαδρομών είναι *quasipolynomial*.

## 4.1 Εξειδικευμένοι Ορισμοί και Γεγονότα

We deal with a typical instance of a non-atomic *bottleneck routing game*,  $\mathcal{G} = (G(V, E), (d_e)_{e \in E}, r)$ .

**Optimal and Nash Flow Properties.** Let  $o$  denote the optimal flow of an instance  $\mathcal{G}$ . We let  $B^*(\mathcal{G}) = B(o)$ . We note that for every subinstance  $\mathcal{H}$  of  $\mathcal{G}$ ,  $B^*(\mathcal{H}) \geq B^*(\mathcal{G})$ .

As noted earlier, in a Nash flow  $f$  all players incur a common bottleneck cost, i.e.  $B(f) = \min_p b_p(f)$ , and for every  $s - t$  path  $p'$ ,  $B(f) \leq b_{p'}(f)$ . We observe that if a flow  $f$  is a Nash flow for an  $s - t$  network  $G(V, E)$ , then the set of edges  $e$  with  $d_e(f_e) \geq B(f)$  comprises an  $s - t$  cut in  $G$ . For the converse, if for some flow  $f$ , there is an  $s - t$  cut consisting of edges  $e$  either with  $f_e > 0$  and  $d_e(f_e) = B(f)$ , or with  $f_e = 0$  and  $d_e(f_e) \geq B(f)$ , then  $f$  is a Nash flow. Moreover, for all bottleneck routing games with linear latencies  $a_e x$ , a flow  $f$  is a Nash flow iff the set of edges  $e$  with  $d_e(f_e) = B(f)$  comprises an  $s - t$  cut.

It can be shown that every bottleneck routing game admits at least one Nash flow (see e.g., [27, Proposition 2]), and that there is an optimal flow that is also a Nash flow (see e.g., [11, Corollary 2]). In general, a bottleneck routing game admits many different Nash flows, each with a possibly different bottleneck cost of the players. Given an instance  $\mathcal{G}$ , we let  $B(\mathcal{G})$  denote the bottleneck cost of the players in the worst Nash flow of  $\mathcal{G}$ , i.e. the Nash flow  $f$  that maximizes  $B(f)$  among all Nash flows. We refer to  $B(\mathcal{G})$  as the worst equilibrium bottleneck cost of  $\mathcal{G}$ . For convenience, for an instance  $\mathcal{G} = (G, c, r)$ , we sometimes write  $B(G, r)$ , instead of  $B(\mathcal{G})$ , to denote the worst equilibrium bottleneck cost of  $\mathcal{G}$ . We note that for every subinstance  $\mathcal{H}$  of  $\mathcal{G}$ ,  $B^*(\mathcal{G}) \leq B^*(\mathcal{H})$ , and that there may be subinstances  $\mathcal{H}$  with  $B(\mathcal{H}) < B(\mathcal{G})$ , which is the essence of Braess's paradox (see e.g., Fig. 12.1).

The following proposition considers the effect of a uniform scaling of the latency functions.

**Proposition 1.** *Let  $\mathcal{G} = (G, c, r)$  be a routing instance, let  $a > 0$ , and let  $\mathcal{G}' = (G, ac, r)$  be the routing instance obtained from  $\mathcal{G}$  if we replace the latency function  $d_e(x)$  of each edge  $e$  with  $ad_e(x)$ . Then, any  $\mathcal{G}$ -feasible flow  $f$  is also  $\mathcal{G}'$ -feasible and has  $B_{\mathcal{G}'}(f) = aB_{\mathcal{G}}(f)$ . Moreover, a flow  $f$  is a Nash flow (resp. optimal flow) of  $\mathcal{G}$  iff  $f$  is a Nash flow (resp. optimal flow) of  $\mathcal{G}'$ .*

*Proof.* Since the traffic rate of both  $\mathcal{G}$  and  $\mathcal{G}'$  is  $r$ , any  $\mathcal{G}$ -feasible flow  $f$  is also  $\mathcal{G}'$ -feasible. Moreover, the  $\mathcal{G}'$ -latency of  $f$  on each edge  $e$  is  $ad_e(f_e)$ . This immediately implies that  $B_{\mathcal{G}'}(f) = aB_{\mathcal{G}}(f)$ , and that  $f$  is a Nash flow (resp. optimal flow) of  $\mathcal{G}$  iff  $f$  is a Nash flow (resp. optimal flow) of  $\mathcal{G}'$ .  $\square$

**Subpath-Optimal Nash Flows.** For a flow  $f$  and any vertex  $u$ , let  $b_f(u)$  denote the minimum bottleneck cost of  $f$  among all  $s - u$  paths. The flow  $f$  is a *subpath-optimal Nash flow* [27] if for any vertex  $u$  and any  $s - t$  path  $p$  with  $f_p > 0$  that includes  $u$ , the bottleneck cost of the  $s - u$  part of  $p$  is  $b_f(u)$ . For example, the Nash flow  $f$  in Fig. 12.1.a is not subpath-optimal, because  $b_f(v) = 0$ , through the edge  $(s, v)$ , while the bottleneck cost of the path  $(s, u, v)$  is 1. For this instance, the only subpath-optimal Nash flow is the optimal flow with  $1/2$  unit on the path  $(s, u, t)$  and  $1/2$  unit on the path  $(s, v, t)$ .

We formally define the problems we will see

**Problem Definitions.**

- **Paradox-Ridden Recognition** (ParRidBC): Given an instance  $\mathcal{G}$ , decide if  $\mathcal{G}$  is paradox-ridden.
- **Best Subnetwork** (BSubNBC): Given an instance  $\mathcal{G}$ , find the best subnetwork  $H^*$  of  $G$ .

We investigate the complexity and the approximability of these fundamental selfish network design problems for bottleneck routing games.

We note that the objective function of BSubNBC is the worst equilibrium bottleneck cost  $B(H, r)$  of a subnetwork  $H$ . Thus, a (polynomial-time) algorithm  $A$  achieves an  $a$ -approximation for BSubNBC if for all instances  $\mathcal{G}$ ,  $A$  returns a subnetwork  $H$  with  $B(H, r) \leq aB(H^*, r)$ . A subtle point is that given a subnetwork  $H$ , we do not know how to efficiently compute the worst equilibrium bottleneck cost  $B(H, r)$  (see also [10, 52], where a similar issue arises). To deal with this delicate issue, our hardness results use a certain subnetwork structure to identify a good approximation to BSubNBC.

**Series-Parallel Networks.** A directed  $s - t$  network is *series-parallel* if it either consists of a single edge  $(s, t)$  or can be obtained from two series-parallel graphs with terminals  $(s_1, t_1)$  and  $(s_2, t_2)$  composed either in series or in parallel. In a *series composition*,  $t_1$  is identified with  $s_2$ ,  $s_1$  becomes  $s$ , and  $t_2$  becomes  $t$ . In a *parallel composition*,  $s_1$  is identified with  $s_2$  and becomes  $s$ , and  $t_1$  is identified with  $t_2$  and becomes  $t$ .

## 4.2 Έννοιες Ισορροπίας και Τοπολογίες που δεν Πάσχουν από το Παράδοξο

We start by discussing two interesting cases where Braess's paradox does not occur. We first show that if we have a bottleneck routing game  $\mathcal{G}$  defined on an  $s - t$  series-parallel network, then  $\rho(\mathcal{G}) = 1$ , and thus Braess's paradox does not occur. We recall that this was also pointed out in [31] for the case of atomic unsplittable bottleneck routing games. Moreover, we note that a directed  $s - t$  network is series-parallel iff it does not contain a  $\partial$ -graph with degree-2 terminals as a topological minor. Therefore, the example in Fig. 12.1 demonstrates that series-parallel networks is the largest class of network topologies for which Braess's paradox does not occur (see also [64] for a similar result for the case of additive routing games).

**Proposition 2.** *Let  $\mathcal{G}$  be bottleneck routing game on an  $s - t$  series-parallel network. Then,  $\rho(\mathcal{G}) = 1$ .*

*Proof.* Let  $f$  be any Nash flow of  $\mathcal{G}$ . We use induction on the series-parallel structure of the network  $G$ , and show that  $f$  is an optimal flow w.r.t the bottleneck cost, i.e., that  $B(f) = B^*(\mathcal{G})$ . For the basis, we observe that the claim holds if  $G$  consists of a single edge  $(s, t)$ . For the inductive step, we distinguish two cases, depending on whether  $G$  is obtained by the series or the parallel composition of two series-parallel networks  $G_1$  and  $G_2$ .

**Series Composition.** First, we consider the case where  $G$  is obtained by the series composition of an  $s - t'$  series-parallel network  $G_1$  and a  $t' - t$  series-parallel network  $G_2$ . We let  $f_1$  and  $f_2$ , both of rate  $r$ , be the restrictions of  $f$  into  $G_1$  and  $G_2$ , respectively.

We start with the case where  $B(f) = B(f_1) = B(f_2)$ . Then, either  $f_1$  is a Nash flow in  $G_1$ , or  $f_2$  is a Nash flow in  $G_2$ . Otherwise, there would be a  $s - t'$  path  $p_1$  in  $G_1$  with bottleneck cost  $b_{p_1}(f_1) < B(f_1)$ , and an  $t' - t$  path  $p_2$  in  $G_2$ , with bottleneck cost  $b_{p_2}(f_2) < B(f_2)$ . Combining  $p_1$  and  $p_2$ , we obtain an  $s - t$  path  $p = p_1 \cup p_2$  in  $G$  with bottleneck cost smaller than  $B(f)$ , which contradicts the hypothesis that  $f$  is a Nash flow of  $\mathcal{G}$ . If  $f_1$  (or  $f_2$ ) is a Nash flow in  $G_1$  (resp.  $G_2$ ), then by induction hypothesis  $f_1$  (resp.  $f_2$ ) is an optimal flow in  $G_1$  (resp. in  $G_2$ ), and thus  $f$  is an optimal flow of  $\mathcal{G}$ .

Otherwise, we assume, without loss of generality, that  $B(f) = B(f_1) < B(f_2)$ . Then,  $f_1$  is a Nash flow in  $G_1$ . Otherwise, there would be an  $s - t'$  path  $p_1$  in  $G_1$  with bottleneck cost  $b_{p_1}(f_1) < B(f_1)$ , which could be combined with any  $t' - t$  path  $p_2$  in  $G_2$ , with bottleneck cost  $B(f_2) < B(f_1)$ , into an  $s - t$  path  $p = p_1 \cup p_2$  with bottleneck cost smaller than  $B(f)$ . The existence of such a path  $p$  contradicts the hypothesis that  $f$  is a Nash flow of  $\mathcal{G}$ .

Therefore, by induction hypothesis  $f_1$  is an optimal flow in  $G_1$ , and thus  $f$  is an optimal flow of  $\mathcal{G}$ .

**Parallel Composition.** Next, we consider the case where  $G$  is obtained by the parallel composition of an  $s - t$  series-parallel network  $G_1$  and an  $s - t$  series-parallel network  $G_2$ . We let  $f_1$  and  $f_2$  be the restriction of  $f$  into  $G_1$  and  $G_2$ , respectively, let  $r_1$  (resp.  $r_2$ ) be the rate of  $f_1$  (resp.  $f_2$ ), and let  $\mathcal{G}_1$  (resp.  $\mathcal{G}_2$ ) be the corresponding routing instance. Then, since  $f$  is a Nash flow of  $\mathcal{G}$ ,  $f_1$  and  $f_2$  are Nash flows of  $\mathcal{G}_1$  and  $\mathcal{G}_2$  respectively, and  $B(f_1) = B(f_2) = B(f)$ . Therefore, by the induction hypothesis,  $f_1$  and  $f_2$  are optimal flows of  $\mathcal{G}_1$  and  $\mathcal{G}_2$ , and  $f$  is an optimal flow of  $\mathcal{G}$ . To see this, we observe that any flow different from  $f$  must route more flow through either  $G_1$  or  $G_2$ . But if the flow through e.g.  $G_1$  is more than  $r_1$ , the bottleneck cost through  $G_1$  would be at least as large as  $B(f_1)$ .  $\square$

Next, we show that any subpath-optimal Nash flow achieves a minimum bottleneck cost, and thus Braess's paradox does not occur if we restrict ourselves to subpath-optimal Nash flows.

**Proposition 3.** *Let  $\mathcal{G}$  be bottleneck routing game, and let  $f$  be any subpath-optimal Nash flow of  $\mathcal{G}$ . Then,  $B(f) = B^*(\mathcal{G})$ .*

*Proof.* Let  $f$  be any subpath-optimal Nash flow of  $\mathcal{G}$ , let  $S$  be the set of vertices reachable from  $s$  via edges with bottleneck cost less than  $B(f)$ , let  $\delta^+(S)$  be the set of edges  $e = (u, v)$  with  $u \in S$  and  $v \notin S$ , and let  $\delta^-(S)$  be the set of edges  $e = (u, v)$ , with  $u \notin S$  and  $v \in S$ . Then, in [27, Lemma 4.5], it is shown that (i)  $(S, V \setminus S)$  is an  $s - t$  cut, (ii) for all edges  $e \in \delta^+(S)$ ,  $d_e(f_e) \geq B(f)$ , (iii) for all edges  $e \in \delta^+(S)$  with  $f_e > 0$ ,  $d_e(f_e) = B(f)$ , and (iv) for all edges  $e \in \delta^-(S)$ ,  $f_e = 0$ .

By (i) and (iv), any optimal flow  $o$  routes at least as much traffic as the subpath-optimal Nash flow  $f$  routes through the edges in  $\delta^+(S)$ . Thus, there is some edge  $e \in \delta^+(S)$  with  $o_e \geq f_e$ , which implies that  $d_e(o_e) \geq d_e(f_e) \geq B(f)$ , where the second inequality follows from (ii). Since  $B^*(\mathcal{G}) = B(o) \geq d_e(o_e)$ , we obtain that  $B^*(\mathcal{G}) = B(f)$ .  $\square$

### 4.3 Η αναγνώριση Paradox – Ridden Περιπτώσεων είναι Δύσκολη

In this section, we show that given a linear bottleneck routing game  $\mathcal{G}$ , it is NP-hard not only to decide whether  $\mathcal{G}$  is paradox-ridden, but also to approximate the best subnetwork within a factor less than  $4/3$ . To this

end, we employ a reduction from the 2-Directed Disjoint Paths problem (2-DDP), where we are given a directed network  $D$  and distinguished vertices  $s_1, s_2, t_1, t_2$ , and ask whether  $D$  contains a pair of vertex-disjoint paths connecting  $s_1$  to  $t_1$  and  $s_2$  to  $t_2$ . 2-DDP was shown NP-complete in [37, Theorem 3], even if the network  $D$  is known to contain two edge-disjoint paths connecting  $s_1$  to  $t_2$  and  $s_2$  to  $t_1$ . In the following, we say that a subnetwork  $D'$  of  $D$  is *good* if  $D'$  contains (i) at least one path outgoing from each of  $s_1$  and  $s_2$  to either  $t_1$  or  $t_2$ , (ii) at least one path incoming to each of  $t_1$  and  $t_2$  from either  $s_1$  or  $s_2$ , and (iii) either no  $s_1 - t_2$  paths or no  $s_2 - t_1$  paths. We say that  $D'$  is *bad* if any of these conditions is violated by  $D'$ . We note that we can efficiently check whether a subnetwork  $D'$  of  $D$  is good, and that a good subnetwork  $D'$  serves as a certificate that  $D$  is a YES-instance of 2-DDP. Then, the following lemma directly implies the hardness result of this section.

**Lemma 4.1.** Let  $I = (D, s_1, s_2, t_1, t_2)$  be any 2-DDP instance. Then, we can construct, in polynomial time, an  $s-t$  network  $G(V, E)$  with a linear latency function  $d_e(x) = a_e x$ ,  $a_e > 0$ , on each edge  $e$ , so that for any traffic rate  $r > 0$ , the bottleneck routing game  $\mathcal{G} = (G, c, r)$  has  $B^*(\mathcal{G}) = r/4$ , and:

1. If  $I$  is a YES-instance of 2-DDP, there exists a subnetwork  $H$  of  $G$  with  $B(H, r) = r/4$ .
2. If  $I$  is a NO-instance of 2-DDP, for all subnetworks  $H'$  of  $G$ ,  $B(H', r) \geq r/3$ .
3. For all subnetworks  $H'$  of  $G$ , either  $H'$  contains a good subnetwork of  $D$ , or  $B(H', r) \geq r/3$ .

*Proof.* We construct a network  $G(V, E)$  with the desired properties by adding 4 vertices,  $s, t, v, u$ , to  $D$  and 9 “external” edges  $e_1 = (s, u)$ ,  $e_2 = (u, v)$ ,  $e_3 = (v, t)$ ,  $e_4 = (s, v)$ ,  $e_5 = (v, s_1)$ ,  $e_6 = (s, s_2)$ ,  $e_7 = (t_1, u)$ ,  $e_8 = (u, t)$ ,  $e_9 = (t_2, t)$  (see also Fig. 11.1.a). The external edges  $e_1$  and  $e_3$  have latency  $d_{e_1}(x) = d_{e_3}(x) = x/2$ . The external edges  $e_4, \dots, e_9$  have latency  $d_{e_i} = x$ . The external edge  $e_2$  and each edge  $e$  of  $D$  have latency  $d_{e_2}(x) = d_e(x) = \varepsilon x$ , for some  $\varepsilon \in (0, 1/4)$ .

We first show that  $B^*(\mathcal{G}) = r/4$ . As for the lower bound, since the edges  $e_1, e_4$ , and  $e_6$  form an  $s-t$  cut in  $G$ , every  $\mathcal{G}$ -feasible flow has a bottleneck cost of at least  $r/4$ . As for the upper bound, we may assume that  $D$  contains an  $s_1 - t_2$  path  $p$  and an  $s_2 - t_1$  path  $q$ , which are edge-disjoint (see also [37, Theorem 3]). Then, we route a flow of  $r/4$  through each of the paths  $(e_4, e_5, p, e_9)$  and  $(e_6, q, e_7, e_8)$ , and a flow of  $r/2$  through the path  $(e_1, e_2, e_3)$ , which gives a bottleneck cost of  $r/4$ .



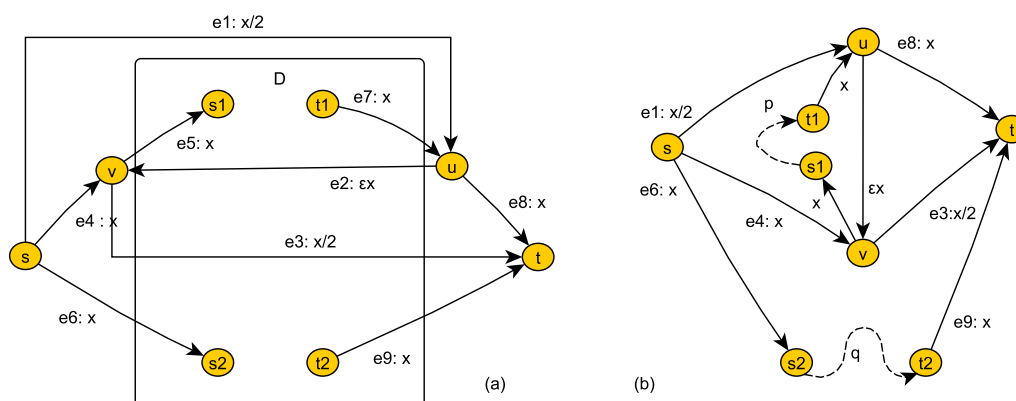

**Figure 4.1:** (a) The network  $G$  constructed in the proof of Lemma 11.1. (b) The best subnetwork of  $G$ , with  $\text{PoA} = 1$ , for the case where  $D$  contains a pair of vertex-disjoint paths connecting  $s_1$  to  $t_1$  and  $s_2$  to  $t_2$ .

Next, we show (1), namely that if  $\mathcal{I}$  is a YES-instance of 2-DDP, then there exists a subnetwork  $H$  of  $G$  with  $B(H, r) = r/4$ . By hypothesis, there is a pair of vertex-disjoint paths in  $D$ ,  $p$  and  $q$ , connecting  $s_1$  to  $t_1$ , and  $s_2$  to  $t_2$ . Let  $H$  be the subnetwork of  $G$  that includes all external edges and only the edges of  $p$  and  $q$  from  $D$  (see also Fig. 11.1.b). We let  $\mathcal{H} = (H, c, r)$  be the corresponding subinstance of  $\mathcal{G}$ . The flow routing  $r/4$  units through each of the paths  $(e_4, e_5, p, e_7, e_8)$  and  $(e_6, q, e_9)$ , and  $r/2$  units through the path  $(e_1, e_2, e_3)$ , is an  $\mathcal{H}$ -feasible Nash flow with a bottleneck cost of  $r/4$ .

We proceed to show that any Nash flow of  $\mathcal{H}$  achieves a bottleneck cost of  $r/4$ . For sake of contradiction, let  $f$  be a Nash flow of  $\mathcal{H}$  with  $B(f) > r/4$ . Since  $f$  is a Nash flow, the edges  $e$  with  $d_e(f_e) \geq B(f)$  form an  $s - t$  cut in  $H$ . Since the bottleneck cost of  $e_2$  and of any edge in  $p$  and  $q$  is at most  $r/4$ , this cut includes either  $e_6$  or  $e_9$  (or both), either  $e_1$  or  $e_3$  (or both), and either  $e_4$  or  $e_8$  (or  $e_5$  or  $e_6$ , in certain combinations with other edges). Let us consider the case where this cut includes  $e_1, e_4$ , and  $e_6$ . Since the bottleneck cost of these edges is greater than  $r/4$ , we have more than  $r/2$  units of flow through  $e_1$  and more than  $r/4$  units of flow through each of  $e_4$  and  $e_6$ . Hence, we obtain that more than  $r$  units of flow leave  $s$ , a contradiction. All other cases are similar.

To conclude the proof, we have also to show (3), namely that for any subnetwork  $H'$  of  $G$ , if  $H'$  does not contain a good subnetwork of  $D$ , then  $B(H', r) \geq r/3$ . We observe that (3) implies (2), because if  $\mathcal{I}$  is a NO-instance, any two paths,  $p$  and  $q$ , connecting  $s_1$  to  $t_1$  and  $s_2$  to  $t_2$ , have some vertex in common, and thus,  $D$  includes no good subnetworks. To show (3), we let  $H'$  be any subnetwork of  $G$ , and let  $\mathcal{H}'$  be the corresponding subinstance

of  $\mathcal{G}$ . We first show that either  $H'$  contains (i) all external edges, (ii) at least one path outgoing from each of  $s_1$  and  $s_2$  to either  $t_1$  or  $t_2$ , and (iii) at least one path incoming to each of  $t_1$  and  $t_2$  from either  $s_1$  or  $s_2$ , or  $H'$  includes a “small”  $s - t$  cut, and thus any  $\mathcal{H}'$ -feasible flow  $f$  has  $B(f) \geq r/3$ .

To prove (i), we observe that if some of the edges  $e_1$ ,  $e_4$ , and  $e_6$  is missing from  $H'$ ,  $r$  units of flow are routed through the remaining ones, which results in a bottleneck cost of at least  $r/3$ . The same argument applies to the edges  $e_3$ ,  $e_8$ , and  $e_9$ . Similarly, if  $e_2$  is not present in  $H'$ , the edges  $e_4$ ,  $e_6$ , and  $e_8$  form an  $s - t$  cut, and routing  $r$  units of flow through them causes a bottleneck cost of at least  $r/3$ . Therefore, we can assume, without loss of generality, that all these external edges are present in  $H'$ .

Now, let us focus on the external edges  $e_5$  and  $e_7$ . If  $e_5$  is not present in  $H'$  and there is a path  $p$  outgoing from  $s_2$  to either  $t_1$  or  $t_2$ , routing  $2r/3$  units of flow through the path  $(e_1, e_2, e_3)$  and  $r/3$  units through the path  $(e_6, p, e_9)$  (or through the path  $(e_6, p, e_7, e_8)$ ) is a Nash flow with a bottleneck cost of  $r/3$  (see also Fig. 11.2.a). If  $s_2$  is connected to neither  $t_1$  nor  $t_2$  (no matter whether  $e_5$  is present in  $H'$  or not), the edges  $e_1$  and  $e_4$  form an  $s - t$  cut, and thus, any  $\mathcal{H}'$ -feasible flow has a bottleneck cost of at least  $r/3$ . Similarly, we can show that if either  $e_7$  is not present in  $H'$ , or neither  $s_1$  nor  $s_2$  is connected to  $t_2$ , any  $\mathcal{H}'$ -feasible flow has a bottleneck cost of at least  $r/3$ . Therefore, we can assume, without loss of generality, that all external edges are present in  $H'$ , and that  $H'$  includes at least one path outgoing from  $s_2$  to either  $t_1$  or  $t_2$ , and at least one path incoming to  $t_2$  from either  $s_1$  or  $s_2$ .

Similarly, we can assume, without loss of generality, that  $H'$  includes at least one path outgoing from  $s_1$  to either  $t_1$  or  $t_2$ , and at least one path incoming to  $t_1$  from either  $s_1$  or  $s_2$ . E.g., if  $s_1$  is connected to neither  $t_1$  nor  $t_2$ , routing  $2r/3$  units of flow through the path  $(e_1, e_2, e_3)$  and  $r/3$  units through  $s_2$  and either  $t_1$  or  $t_2$  (or both) is a Nash flow with a bottleneck cost of  $r/3$ . A similar argument applies to the case where neither  $s_1$  nor  $s_2$  is connected to  $t_1$ .

Let us now consider a subnetwork  $H'$  of  $G$  that does not contain a good subnetwork of  $D$ , but it contains (i) all external edges, (ii) at least one path outgoing from each of  $s_1$  and  $s_2$  to either  $t_1$  or  $t_2$ , and (iii) at least one path incoming to each of  $t_1$  and  $t_2$  from either  $s_1$  or  $s_2$ . By (ii) and (iii), and the hypothesis that the subnetwork of  $D$  included in  $H'$  is bad,  $H'$  contains an  $s_1 - t_2$  path  $p$  and an  $s_2 - t_1$  path  $q$  (see also Fig. 11.2.b). At the intuitive level, this corresponds to the case where no edges are removed from  $G$ . Then, routing  $r/3$  units of flow on each of the  $s - t$  paths  $(e_1, e_2, e_3)$ ,  $(e_1, e_2, e_5, p, e_9)$ , and  $(e_6, q, e_7, e_2, e_3)$  has a bottleneck cost of  $r/3$  and is a Nash flow, because the set of edges with bottleneck cost  $r/3$  comprises an

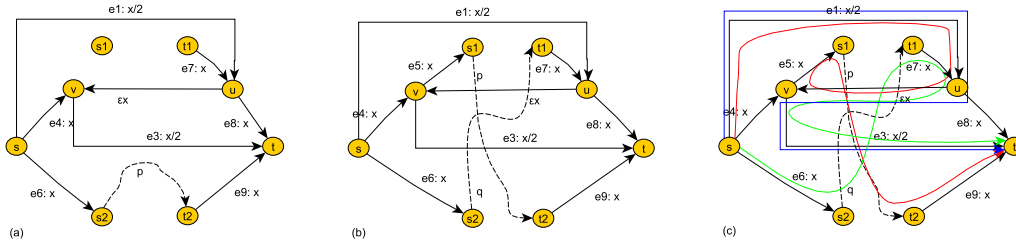

**Figure 4.2:** Possible subnetworks of  $G$  when there is no pair of vertex-disjoint paths connecting  $s_1$  to  $t_1$  and  $s_2$  to  $t_2$ . The subnetwork (a) contains an  $s_2 - t_2$  path and does not include  $e_5$ . In the subnetwork (b), we essentially have all edges of  $G$ . In (c), we depict a Nash flow that consists of three paths, each carrying  $r/3$  units of flow, and has a bottleneck cost of  $r/3$ .

$s - t$  cut (see also Fig. 11.2.c). Therefore, we have shown part (3) of the lemma, which in turn, immediately implies part (2).  $\square$

We note that the bottleneck routing game  $\mathcal{G}$  in the proof of Lemma 11.1 has  $\rho(\mathcal{G}) = 4/3$ , and is paradox-ridden, if  $\mathcal{I}$  is a YES instance of 2-DDP, and paradox-free, otherwise. Thus, we obtain that:

**Theorem 4.2.** Deciding whether a bottleneck routing game with strictly increasing linear latencies is paradox-ridden is NP-hard.

Moreover, Lemma 11.1 implies that it is NP-hard to approximate BSubNBC within a factor less than  $4/3$ . The subtle point here is that given a subnetwork  $H$ , we do not know how to efficiently compute the worst equilibrium bottleneck cost  $B(H, r)$ . However, we can use the notion of a good subnetwork of  $D$  and deal with this issue. Specifically, let  $A$  be any approximation algorithm for BSubNBC with approximation ratio less than  $4/3$ . Then, if  $D$  is a YES-instance of 2-DDP,  $A$  applied to the network  $G$ , constructed in the proof of Lemma 11.1, returns a subnetwork  $H$  with  $B(H, r) < r/3$ . Thus, by Lemma 11.1,  $H$  contains a good subnetwork of  $D$ , which can be checked in polynomial time. If  $D$  is a NO-instance,  $D$  contains no good subnetworks. Hence, the outcome of  $A$  would allow us to distinguish between YES and NO instances of 2-DDP.

**Remark 4.3.** If we let the edges to have more general latency functions, such as polynomials of greater degree or exponential functions, then we can get greater inapproximability factors for BSubNBC.

For example, if we use the cost functions  $x^d$  instead of  $x$  and  $x^d/2^d$  instead of  $x/2$  in network  $G$  in the proof of Lemma 11.1 (fig. 11.1), then we will get an inapproximability ratio of  $(4/3)^d$ .

Using  $a^x$  instead of  $x$  and  $a^{x/2}$  instead of  $x/2$  in the proof of Lemma 11.1 (fig. 11.1), we get an inapproximability ratio of  $a^{r/12} = B^*(\mathcal{G})^{1/3}$  (depending on  $a$  and  $r$ ).

## 4.4 Η Προσεγγισημοτητα του Καλύτερου Υποδικτύου είναι Δύσκολη

Next, we apply essentially the same construction as in the proof of Lemma 11.1, but in a recursive way, and show that it is NP-hard to approximate BSubNBC for linear bottleneck routing games within a factor of  $O(n^{121-\varepsilon})$ , for any constant  $\varepsilon > 0$ . Throughout this section, we let  $\mathcal{I} = (D, s_1, s_2, t_1, t_2)$  be a 2-DDP instance, and let  $G$  be an  $s - t$  network, which includes (possibly many copies of)  $D$  and can be constructed from  $\mathcal{I}$  in polynomial time. We assume that  $G$  has a linear latency function  $d_e(x) = a_e x$ ,  $a_e > 0$ , on each edge  $e$ , and for any traffic rate  $r > 0$ , the bottleneck routing game  $\mathcal{G} = (G, c, r)$  has  $B^*(\mathcal{G}) = r/\gamma_1$ , for some  $\gamma_1 > 0$ . Moreover,

1. If  $\mathcal{I}$  is a YES-instance of 2-DDP, there exists a subnetwork  $H$  of  $G$  with  $B(H, r) = r/\gamma_1$ .
2. If  $\mathcal{I}$  is a NO-instance of 2-DDP, for all subnetworks  $H'$  of  $G$ ,  $B(H', r) \geq r/\gamma_2$ , for a  $\gamma_2 \in (0, \gamma_1)$ .
3. For all subnetworks  $H'$  of  $G$ , either  $H'$  contains at least one copy of a good subnetwork of  $D$ , or  $B(H', r) \geq r/\gamma_2$ .

The existence of such a network shows that it is NP-hard to approximate BSubNBC within a factor less than  $\gamma = \gamma_1/\gamma_2$ . Thus, we usually refer to  $G$  as a  $\gamma$ -gap instance (with linear latencies). For example, for the network  $G$  in the proof of Lemma 11.1,  $\gamma_1 = 4$  and  $\gamma_2 = 3$ , and thus  $G$  is a  $4/3$ -gap instance. We next show that given  $\mathcal{I}$  and a  $\gamma_1/\gamma_2$ -gap instance  $G$ , we can construct a  $(4\gamma_1)/(3\gamma_2)$ -gap instance  $G'$ , i.e., we can amplify the inapproximability gap by a factor of  $4/3$ .

**Lemma 4.4.** Let  $\mathcal{I} = (D, s_1, s_2, t_1, t_2)$  be a 2-DDP instance, and let  $G$  be a  $\gamma_1/\gamma_2$ -gap instance with linear latencies, based on  $\mathcal{I}$ . Then, we can construct, in time polynomial in the size of  $\mathcal{I}$  and  $G$ , an  $s - t$  network  $G'$  with a linear latency function  $d_e(x) = a_e x$ ,  $a_e > 0$ , on each edge  $e$ , so that for any traffic rate  $r > 0$ , the bottleneck routing game  $\mathcal{G}' = (G', c, r)$  has  $B^*(\mathcal{G}') = r/(4\gamma_1)$ , and:

1. If  $I$  is a YES-instance of 2-DDP, there exists a subnetwork  $H$  of  $G'$  with  $B(H, r) = r/(4\gamma_1)$ .
2. If  $I$  is a NO-instance of 2-DDP, for every subnetwork  $H'$  of  $G'$ ,  $B(H', r) \geq r/(3\gamma_2)$ .
3. For all subnetworks  $H'$  of  $G'$ , either  $H'$  contains at least one copy of a good subnetwork of  $D$ , or  $B(H', r) \geq r/(3\gamma_2)$ .

*Proof.* Starting from  $D$ , we obtain  $G'$  by applying the construction of Lemma 11.1, but with all external edges, except for  $e_2$ , replaced by a copy of the gap-instance  $G$ . For convenience, we refer to the copy of the gap-instance replacing the external edge  $e_i$ ,  $i \in \{1, 3, \dots, 9\}$ , as the *edgework*  $G_i$ . Formally, to obtain  $G'$ , we start from  $D$  and add four new vertices,  $s, t, v, u$ . We connect  $s$  to  $u$ , with the  $s - u$  edgework  $G_1$ , and  $v$  to  $t$ , with the  $s - u$  edgework  $G_3$ , where in both  $G_1$  and  $G_3$ , we replace the latency function  $d_e(x)$  of each edge  $e$  in the gap instance with  $d_e(x)/2$  (this is because in Lemma 11.1, the external edges  $e_1$  and  $e_3$  have latencies  $x/2$ ). Moreover, instead of the external edge  $e_i$ ,  $i \in \{4, \dots, 9\}$ , we connect  $(s, v)$ ,  $(v, s_1)$ ,  $(s, s_2)$ ,  $(t_1, u)$ ,  $(u, t)$ , and  $(t_2, t)$  with the edgework  $G_i$ . The latencies in these edgeworks are as in the gap instance. Furthermore, we add the external edge  $e_2 = (u, v)$  with latency  $d_{e_2}(x) = \varepsilon x$ , for some  $\varepsilon \in (0, \frac{1}{4\gamma_1})$  (see also Fig. 11.3.a). Also, each edge  $e$  of  $D$  has latency  $d_e(x) = \varepsilon x$ . We next consider the corresponding routing instance  $\mathcal{G}'$  with an arbitrary traffic rate  $r > 0$ . Throughout the proof, when we define a routing instance, we omit, for simplicity, the coordinate  $c$ , referring to the latency functions, with the understanding that they are defined as above.

Intuitively, each  $G_i$ ,  $i \in \{4, \dots, 9\}$ , behaves as an external edge (hence the term edge(network)), which at optimality has a bottleneck cost of  $r/\gamma_1$ , for any traffic rate  $r$  entering  $G_i$ . Moreover, if  $I$  is a YES-instance of 2-DDP, the edgework  $G_i$  has a subedgework  $H_i$  for which  $B(H_i, r) = r/\gamma_1$ , for any  $r$ , while if  $H_i$  does not contain any copies of a good subnetwork of  $D$  (or, if  $I$  is a NO-instance), for all subedgeworks  $H'_i$  of  $G_i$ ,  $B(H'_i, r) \geq r/\gamma_2$ , for any  $r$ . The same holds for  $G_1$  and  $G_3$ , but with a worst equilibrium bottleneck cost of  $r/(2\gamma_1)$  in the former case, and of  $r/(2\gamma_2)$  in the latter case, because the latency functions of  $G_1$  and  $G_3$  are scaled by  $1/2$  (see also Proposition 9).

The proofs of the following propositions are conceptually similar to the proofs of the corresponding claims in the proof Lemma 11.1.

**Proposition 4.** *The optimal bottleneck cost of  $\mathcal{G}'$  is  $B^*(\mathcal{G}') = r/(4\gamma_1)$ .*

*Proof.* We have to show that  $B^*(\mathcal{G}') = r/(4\gamma_1)$ . For the upper bound, as in the proof of Lemma 11.1, we assume that  $D$  contains an  $s_1 - t_2$  path

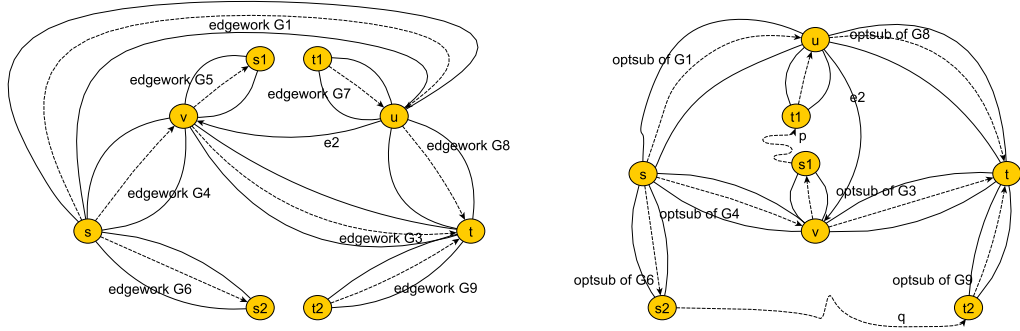

**Figure 4.3:** (a) The network  $G'$  constructed in the proof of Lemma 11.4. The structure of  $G'$  is similar to the structure of the network  $G$  in Fig. 11.1, with each external edge  $e_i$ , except for  $e_2$ , replaced by the edgework  $G_i$ . (b) The structure of a best subnetwork  $H$  of  $G'$ , with  $\text{PoA} = 1$ , when  $D$  contains a pair of vertex-disjoint paths,  $p$  and  $q$ , connecting  $s_1$  to  $t_1$  and  $s_2$  to  $t_2$ . To complete  $H$ , we use an optimal subnetwork (or simply, subedgework) of each edgework  $G_i$ .

$p$  and an  $s_2 - t_1$  path  $q$ , which are edge-disjoint. We route (i)  $r/4$  units of flow through the edgeworks  $G_4, G_5$ , next through the path  $p$ , and next through the edgework  $G_9$ , (ii)  $r/4$  units through the edgeworks  $G_6$ , next through the path  $q$ , and next through the edgeworks  $G_7$  and  $G_8$ , and (iii)  $r/2$  units through the edgework  $G_1$ , next through the external edge  $e_2$ , and next through the edgework  $G_3$ . These routes are edge(work)-disjoint, and if we route the flow optimally through each edgework, the bottleneck cost is  $r/(4\gamma_1)$ . As for the lower bound, we observe that the edgeworks  $H_1, H_4$ , and  $H_6$  essentially form an  $s - t$  cut in  $G'$ , and thus every feasible flow has a bottleneck cost of at least  $r/(4\gamma_1)$ .  $\square$

**Proposition 5.** *If  $\mathcal{I}$  is a YES-instance, there is a subnetwork  $H$  of  $G'$  with  $B(H, r) = r/(4\gamma_1)$ .*

*Proof.* If  $\mathcal{I}$  is a YES-instance of 2-DDP, then (i) there are two vertex-disjoint paths in  $D$ ,  $p$  and  $q$ , connecting  $s_1$  to  $t_1$  and  $s_2$  to  $t_2$ , and (ii) there is an optimal subnetwork (or simply, subedgework)  $H_i$  of each edgework  $G_i$  so that for any traffic rate  $r$  routed through  $H_i$ , the worst equilibrium bottleneck cost  $B(H_i, r)$  is  $r/\gamma_1$ , if  $i \in \{4, \dots, 9\}$ , and  $r/(2\gamma_1)$ , if  $i \in \{1, 3\}$ . Let  $H$  be the subnetwork of  $G'$  that consists of only the edges of the paths  $p$  and  $q$  from  $D$ , of the external edge  $e_2$ , and of the optimal subedgeworks  $H_i$ ,  $i \in \{1, 3, \dots, 9\}$  (see also Fig. 11.3.b). We observe that we can route: (i)  $r/4$  units of flow through the subedgeworks  $H_4, H_5$ , next through the path  $p$ , and next through the subedgeworks  $H_7$  and  $H_8$ , (ii)  $r/4$  units of flow through the subedgework  $H_6$ , next through the path  $q$ , and next through

the subedgework  $H_9$ , and (iii)  $r/2$  units of flow through the subedgework  $H_1$ , next through the external edge  $e_2$ , and next through the subedgework  $H_3$ . These routes are edge(work)-disjoint, and if we use any Nash flow through each of the routing instances  $(H_i, r/4)$ ,  $i \in \{4, \dots, 9\}$ ,  $(H_1, r/2)$ , and  $(H_3, r/2)$ , we obtain a Nash flow of the instance  $(H, r)$  with a bottleneck cost of  $r/(4\gamma_1)$ .

We next show that any Nash flow of  $(H, r)$  has a bottleneck cost of at most  $r/(4\gamma_1)$ . To reach a contradiction, let us assume that some feasible Nash flow  $f$  has bottleneck cost  $B(f) > r/(4\gamma_1)$ . We recall that  $f$  is a Nash flow iff the edges of  $G'$  with bottleneck cost  $B(f) > r/(4\gamma_1)$  form an  $s-t$  cut. This cut does not include the edges of the paths  $p$  and  $q$  and the external edge  $e_2$ , due to the choice of their latencies. Hence, this cut includes a similar cut either in  $H_6$  or in  $H_9$  (or in both), either in  $H_1$  or  $H_3$  (or in both), and either in  $H_4$  or in  $H_8$  (or in  $H_5$  or in  $H_6$ , in certain combinations with other subedgeworks, see also Fig. 11.3.b). Let us consider the case where the edges with bottleneck cost  $B(f) > r/(4\gamma_1)$  form a cut in  $H_1$ ,  $H_4$ , and  $H_6$ . Namely, the edges of  $H_1$ ,  $H_4$ , and  $H_6$ , with bottleneck cost equal to  $B(f) > r/(4\gamma_1)$  form an  $s-u$ , an  $s-v$ , and an  $s-s_2$  cut, respectively, and thus the restriction of  $f$  to each of  $H_1$ ,  $H_4$ , and  $H_6$ , is an equilibrium flow of bottleneck cost greater than  $r/(4\gamma_1)$  for the corresponding routing instance. Since  $\mathcal{I}$  is a YES-instance, this can happen only if the flow through  $H_1$  is more than  $r/2$ , and the flow through each of  $H_4$  and  $H_6$  is more than  $r/4$  (see also property (ii) of optimal subedgeworks above). Hence, we obtain that more than  $r$  units of flow leave  $s$ , a contradiction. All other cases are similar.  $\square$

The most technical part of the proof is to show (3), namely that for any subnetwork  $H'$  of  $G'$ , if  $H'$  does not contain any copies of a good subnetwork of  $D$ , then  $B(H', r) \geq r/(3\gamma_2)$ . This immediately implies (2), since if  $\mathcal{I}$  is a NO-instance of 2-DDP,  $D$  includes no good subnetworks. To prove (3), we consider any subnetwork  $H'$  of  $G'$ , and let  $H'_i$  be the subedgework of each  $G_i$  present in  $H'$ . We assume that the subedgeworks  $H'_i$  do not contain any copies of a good subnetwork of  $D$ , and show that if the subnetwork of  $D$  connecting  $s_1$  and  $s_2$  to  $t_1$  and  $t_2$  in  $H'$  is also bad, then  $B(H', r) \geq r/(3\gamma_2)$ .

At the technical level, we repeatedly use the idea of a flow  $f_i$  through a subedgework  $H'_i$  that “saturates”  $H'_i$ , in the sense that  $f_i$  is a Nash flow with bottleneck cost at least  $r_i/(3\gamma_2)$  for the subinstance  $(H'_i, r_i)$ . Formally, we say that a flow rate  $r_i$  saturates a subedgework  $H'_i$  if  $B(H'_i, r_i) \geq r_i/(3\gamma_2)$ . We refer to the flow rate  $r_i^s$  for which  $B(H'_i, r_i^s) = r_i^s/(3\gamma_2)$  as the *saturation rate* of  $H'_i$ . We note that the saturation rate  $r_i^s$  is well-defined, because the latency functions of  $G_i$ s are linear and strictly increasing. Moreover,

by property (3) of gap instances, the saturation rate of each subedgework  $H'_i$  is  $r_i^s \leq r/3$ , if  $i \in \{4, \dots, 9\}$ , and  $r_i^s \leq 2r/3$ , if  $i \in \{1, 3\}$ . Thus, at the intuitive level, the subedgeworks  $H'_i$  behave as the external edges of the network constructed in the proof of Lemma 11.1. Hence, to show that  $B(H', r) \geq r/(3\gamma_2)$ , we need to construct a flow of rate (at most)  $r$  that saturates a collection of subedgeworks comprising an  $s - t$  cut in  $H'$ .

Our first step in this direction is to simplify the possible structure of  $H'$ .

**Proposition 6.** *Let  $H'$  be any subnetwork of  $G'$  whose subedgeworks  $H'_i$  do not contain any copies of a good subnetwork of  $D$ . Then, either the subnetwork  $H'$  contains (i) the external edge  $e_2$ , (ii) at least one path outgoing from each of  $s_1$  and  $s_2$  to either  $t_1$  or  $t_2$ , and (iii) at least one path incoming to each of  $t_1$  and  $t_2$  from either  $s_1$  or  $s_2$ , or  $B(H', r) \geq r/(3\gamma_2)$ .*

*Proof.* For convenience, in the proofs of Proposition 14 and Proposition 15, we slightly abuse the terminology, and say that a collection of subedgeworks of  $H'$  form an  $s - t$  cut, if the union of any cuts in them comprises an  $s - t$  cut in  $H'$ . Moreover, whenever we write that  $r_i$  units of flow are routed through a subedgework  $H_i$ , we assume that the routing through  $H_i$  corresponds to the worst Nash flow of  $(H_i, r_i)$ . Also, we recall that since subedgeworks  $H'_i$  do not contain any copies of a good subnetwork of  $D$ , by property (3) of gap instances, the saturation rate of each  $H'_i$  is  $r_i^s \leq r/3$ , if  $i \in \{4, \dots, 9\}$ , and  $r_i^s \leq 2r/3$ , if  $i \in \{1, 3\}$ .

We start by showing that either the external edge  $e_2$  is present in  $H'$ , or  $B(H', r) \geq r/(3\gamma_2)$ . Indeed, if  $e_2$  is not present in  $H'$ , the subedgeworks  $H'_4, H'_6$ , and  $H'_8$  form an  $s - t$  cut in  $H'$ . Therefore, we can construct a Nash flow  $f$  that routes at least  $r/3$  units of flow through  $H'_4, H'_6$ , and  $H'_8$ , and has  $B(f) \geq r/(3\gamma_2)$ . Therefore, we can assume, without loss of generality, that  $e_2$  is present in  $H'$ .

Similarly, we show that either  $H'$  includes at least one path outgoing from  $s_2$  to either  $t_1$  or  $t_2$ , and at least one path incoming to  $t_2$  from either  $s_1$  or  $s_2$ , or  $B(H', r) \geq r/(3\gamma_2)$ . In particular, if  $s_2$  is connected to neither  $t_1$  nor  $t_2$ , the subedgeworks  $H'_1$  and  $H'_4$  form an  $s - t$  cut in  $H'$ . Thus, we can construct a Nash flow  $f$  that saturates the subedgework  $H'_1$  (or the subedgeworks  $H'_3$  and  $H'_8$ , if  $r_1^s > r_3^s + r_8^s$ ) and the subedgework  $H'_4$  (or the subedgeworks  $H'_3$  and either  $H'_5$ , or  $H'_9$  and at least one of the  $H'_7$  and  $H'_8$ , depending on  $r_4^s$  and the saturation rates of the rest). We note that this is always possible with  $r$  units of flow, because  $r_1^s \leq 2r/3$  and  $r_4^s \leq r/3$ . Therefore, the bottleneck cost of  $f$  is  $B(f) \geq r/(3\gamma_2)$ . In case where there is no path incoming to  $t_2$  from either  $s_1$  or  $s_2$ , the subedgeworks  $H'_3$  and  $H'_8$  form an  $s - t$  cut in  $H'$ . As before, we can construct a Nash flow  $f$



that saturates the subedgeworks  $H'_3$  and  $H'_8$  (or, as before, an appropriate combination of other subedgeworks carrying flow to  $H'_3$  and  $H'_8$ ), and has  $B(f) \geq r/(3\gamma_2)$ . Therefore, we can assume, without loss of generality, that  $H'$  includes at least one path outgoing from  $s_2$  to either  $t_1$  or  $t_2$ , and at least one path incoming to  $t_2$  from either  $s_1$  or  $s_2$ .

Next, we show that either  $H'$  includes at least one path outgoing from  $s_1$  to either  $t_1$  or  $t_2$ , and at least one path incoming to  $t_1$  from either  $s_1$  or  $s_2$ , or  $B(H', r) \geq r/(3\gamma_2)$ . In particular, let us consider the case where  $s_1$  is connected to neither  $t_1$  nor  $t_2$  (see also Fig. 11.4.a, the case where there is no path incoming to  $t_1$  from either  $s_1$  or  $s_2$  can be handled similarly). In the following, we assume that  $s_2$  is connected to  $t_2$  (because, by the analysis above, we can assume that there is a path incoming to  $t_2$ , and  $s_1$  is not connected to  $T_2$ ), and construct a Nash flow  $f$  of bottleneck cost  $B(f) \geq r/(3\gamma_2)$ .

We first route  $\min\{r_6^s, r_9^s\} \leq r/3$  units of flow through the subedgework  $H'_6$ , next through an  $s_2 - t_2$  path, and finally through the subedgework  $H'_9$ , and saturate either  $H'_6$  or  $H'_9$  (or both). If there is an  $s_2 - t_1$  path and  $H'_6$  is not saturated, we keep routing flow through  $H'_6$ , next through an  $s_2 - t_1$  path, and next through the subedgeworks  $H'_7$  and  $H'_8$ , until either the subedgework  $H'_6$  or at least one of the subedgeworks  $H'_7$  and  $H'_8$  become saturated. Thus, we saturate at least one edgework on every  $s - t$  path that includes  $s_2$ .

Next, we show how to saturate at least one edgework on every  $s - t$  path that includes either  $v$  or  $u$ . If  $r_1^s \leq r_3^s \leq 2r/3$ , we route  $r_1^s$  units of flow through  $H'_1$ ,  $e_2$ , and  $H'_3$ , and route  $\min\{r_3^s - r_1^s, r_4^s\}$  units of flow through  $H'_4$  and  $H'_3$ , and saturate either  $H'_1$  and  $H'_3$  or  $H'_1$  and  $H'_4$ . If  $r_3^s < r_1^s \leq 2r/3$ , we route  $r_3^s$  units of flow through  $H'_1$ ,  $e_2$ , and  $H'_3$ , and route  $\min\{r_3^s - r_1^s, r_8^s\}$  units of flow through  $H'_1$  and  $H'_8$ , and saturate either  $H'_1$  and  $H'_3$  or  $H'_3$  and  $H'_8$ .

The remaining flow (if any) can be routed through these routes, in proportional rates. In all cases, we obtain an  $s - t$  cut consisting of saturated subedgeworks. Thus, the resulting flow  $f$  is a Nash flow with a bottleneck cost of at least  $r/(3\gamma_2)$ . □

Now, let us focus on a subnetwork  $H'$  of  $G'$  that contains (i) the external edge  $e_2$ , (ii) at least one path outgoing from each of  $s_1$  and  $s_2$  to either  $t_1$  or  $t_2$ , and (iii) at least one path incoming to each of  $t_1$  and  $t_2$  from either  $s_1$  or  $s_2$ . If the copy of the subnetwork of  $D$  connecting  $s_1$  and  $s_2$  to  $t_1$  and  $t_2$  in  $H'$  is also bad, properties (ii) and (iii) imply that  $H'$  contains an  $s_1 - t_2$  path  $p$  and an  $s_2 - t_1$  path  $q$ . In this case, the entire subnetwork  $H'$

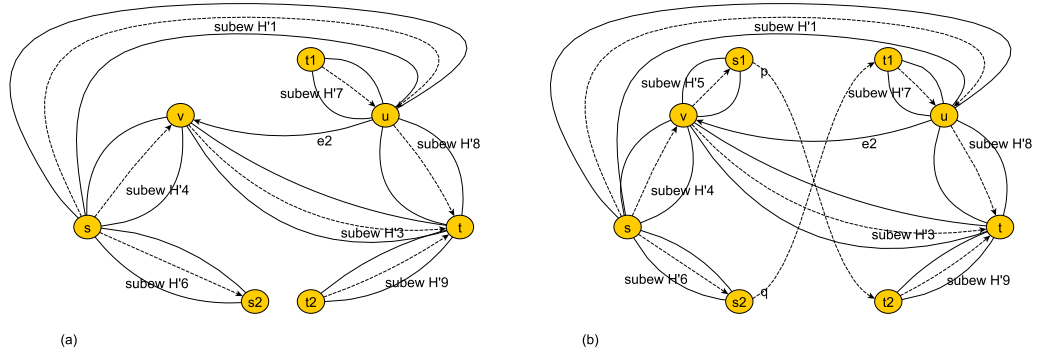

**Figure 4.4:** The structure of possible subnetworks of  $G'$  when there is no pair of vertex-disjoint paths connecting  $s_1$  to  $t_1$  and  $s_2$  to  $t_2$ . The subnetwork (a) contains a path outgoing from  $s_2$  to either  $t_1$  or  $t_2$ , and no path outgoing from  $s_1$  to either  $t_1$  or  $t_2$ . Hence, no flow can be routed through the edgework  $G_5$ , and thus we can regard  $G_5$  as being absent from  $H'$ . The subnetwork (b) essentially corresponds to the case where all edges of  $G'$  are present in  $H'$ .

essentially behaves as if it included all edges of  $G'$ . Then, a routing similar to that in Fig. 11.2.c gives a Nash flow with a bottleneck cost of  $r/(3\gamma_2)$ . This intuition is formalized by the following proposition.

**Proposition 7.** *Let  $H'$  be any subnetwork of  $G'$  that satisfies (i), (ii), and (iii) above, and does not contain any copies of a good subnetwork of  $D$ . Then  $B(H', r) \geq r/(3\gamma_2)$ .*

*Proof.* In the following, we consider a subnetwork  $H'$  of  $G'$  which does not include any copies of a good subnetwork of  $D$ , and contains (i) the external edge  $e_2$ , (ii) at least one path outgoing from each of  $s_1$  and  $s_2$  to either  $t_1$  or  $t_2$ , and (iii) at least one path incoming to each of  $t_1$  and  $t_2$  from either  $s_1$  or  $s_2$ . Since the copy of the subnetwork of  $D$  connecting  $s_1$  and  $s_2$  to  $t_1$  and  $t_2$  in  $H'$  is bad, properties (ii) and (iii) imply that  $H'$  contains an  $s_1 - t_2$  path  $p$  and an  $s_2 - t_1$  path  $q$ . Moreover, since the subedgeworks  $H'_i$  do not include any copies of a good subnetwork of  $D$ , by property (3) of gap instances, the saturation rate of each  $H'_i$  is  $r_i^s \leq r/3$ , if  $i \in \{4, \dots, 9\}$ , and  $r_i^s \leq 2r/3$ , if  $i \in \{1, 3\}$ .

We next show that for such a subnetwork  $H'$ , we can construct a Nash flow  $f$  of bottleneck cost  $B(f) \geq r/(3\gamma_2)$ . At the conceptual level, as in the last case in the proof of Lemma 11.1, we seek to construct a Nash flow by routing  $r/3$  units of flow through each of the following three routes: (i)  $H'_1$ ,  $e_2$ , and  $H'_3$ , (ii)  $H'_1$ ,  $e_2$ ,  $H'_5$ ,  $p$ , and  $H'_9$ , and (iii)  $H'_6$ ,  $q$ ,  $H'_7$ ,  $e_2$ , and  $H'_3$ . However, for simplicity of the analysis, we regard the corresponding (edge) flow as being routed through just two routes: a rate of  $2r/3$  is routed through  $H'_1$ ,

$e_2$ , and  $H'_3$ , and a rate of  $r/3$  is routed through the (possibly non-simple) route  $H'_6$ ,  $q$ ,  $H'_7$ ,  $e_2$ ,  $H'_5$ ,  $p$ , and  $H'_9$ . We do so because the latter routing allows us to consider fewer cases in the analysis. We conclude the proof by showing that if the latter route is not simple, we can always decompose the flow into the three simple routes above.

In the following, we assume that with a flow rate of at most  $2r/3$ , routed through  $H'_1$ ,  $e_2$ , and  $H'_3$  (and possibly through  $H'_4$  and  $H'_8$ ), we can saturate both subedgeworks  $H'_1$  and  $H'_3$ . Otherwise, as in the last case in the proof of Proposition 14, we can show how with a total flow rate of at most  $2r/3$ , part of which is routed through either  $H'_4$  or  $H'_8$ , we can saturate either  $H'_1$  and  $H'_4$ , or  $H'_3$  and  $H'_8$ . Then, the remaining  $r/3$  units of flow can saturate either  $H'_6$ , in the former case, or  $H'_9$ , in the latter case. Thus, we obtain a Nash flow with a bottleneck cost of at least  $r/(3\gamma_2)$ .

Having saturated both subedgeworks  $H'_1$  and  $H'_3$ , using at most  $2r/3$  units of flow, we have at least  $r/3$  units of flow to saturate the subedgeworks  $H'_5$ ,  $H'_6$ ,  $H'_7$ , and  $H'_9$ , or an appropriate subset of them, so that together with  $H'_1$  and  $H'_3$ , they form an  $s - t$  cut in  $H'$ . We first route  $\tau \equiv \min\{r_5^s, r_6^s, r_7^s, r_9^s\} \leq r/3$  units of flow through  $H'_6$ ,  $q$ ,  $H'_7$ ,  $e_2$ ,  $H'_5$ ,  $p$ , and  $H'_9$ , until  $t$ , and consider different cases, depending on which of the subedgeworks  $H'_5$ ,  $H'_6$ ,  $H'_7$ , and  $H'_9$  has the minimum saturation rate.

- If  $\tau = r_9^s$ ,  $H'_9$  is saturated. We first assume that  $H'$  contains an  $s_1 - t_1$  path, and route (some of) the remaining flow (i) through  $H'_4$ ,  $H'_5$ , an  $s_1 - t_1$  path,  $H'_7$ , and  $H'_8$ , and (ii) through  $H'_6$ ,  $q$ ,  $H'_7$ , and  $H'_8$ . We do so until either at least one of the subedgeworks  $H'_7$  and  $H'_8$  or the subedgework  $H'_6$  and at least one of the subedgeworks  $H'_4$  and  $H'_5$  become saturated. Since  $\min\{r_7^s, r_8^s\} \leq r/3$ , this requires at most  $r/3 - \tau$  additional units of flow. If  $H'$  does not contain an  $s_1 - t_1$  path, we route the remaining flow only through route (ii), until either at least one of the subedgeworks  $H'_7$  and  $H'_8$  or the subedgework  $H'_6$  become saturated. In both cases, the newly saturated subedgeworks, together with the saturated subedgeworks  $H'_1$ ,  $H'_3$ , and  $H'_9$ , form an  $s - t$  cut of saturated subedgeworks, and thus the worst equilibrium bottleneck cost is at least  $r/(3\gamma_2)$ .
- If  $\tau = r_6^s$ ,  $H'_6$  is saturated. As before, we first assume that  $H'$  contains an  $s_1 - t_1$  path, and route the remaining flow (i) through  $H'_4$ ,  $H'_5$ ,  $p$ , and  $H'_9$ , and (ii) through  $H'_4$ ,  $H'_5$ , an  $s_1 - t_1$  path,  $H'_9$  and  $H'_8$ , until either at least one of the subedgeworks  $H'_4$  and  $H'_5$ , or the subedgework  $H'_9$  and at least one of the subedgeworks  $H'_7$  and  $H'_8$  become saturated. Since  $\min\{r_4^s, r_5^s\} \leq r/3$ , this requires at most  $r/3 - \tau$  additional units of flow.

If  $H'$  does not contain an  $s_1 - t_1$  path, we route the remaining flow only through route (i), until either at least one of the subedgeworks  $H'_4$  and  $H'_5$  or the subedgework  $H'_9$  become saturated. In both cases, the newly saturated subedgeworks, together with the saturated subedgeworks  $H'_1$ ,  $H'_3$ , and  $H'_6$ , form an  $s - t$  cut of saturated subedgeworks, and thus the worst equilibrium bottleneck cost is at least  $r/(3\gamma_2)$ .

- If  $\tau = r_7^s$ ,  $H'_7$  is saturated. Then, we first assume that  $H'$  contains an  $s_2 - t_2$  path, and route the remaining flow (i) through  $H'_4$ ,  $H'_5$ ,  $p$ , and  $H'_9$ , and (ii) through  $H'_6$ , an  $s_2 - t_2$  path, and  $H'_9$ , until either the subedgework  $H'_9$ , or the subedgework  $H'_6$  and at least one of the subedgeworks  $H'_4$  and  $H'_5$  become saturated. Since  $r_9^s \leq r/3$ , this requires at most  $r/3 - \tau$  additional units of flow. If  $H'$  does not contain an  $s_2 - t_2$  path, we route the remaining flow only through route (i), until either at least one of the subedgeworks  $H'_4$  and  $H'_5$  or the subedgework  $H'_9$  become saturated. In both cases, the newly saturated subedgeworks, together with the saturated subedgeworks  $H'_1$ ,  $H'_3$ , and  $H'_7$ , form an  $s - t$  cut of saturated subedgeworks, and thus the worst equilibrium bottleneck cost is at least  $r/(3\gamma_2)$ .
- If  $\tau = r_5^s$ ,  $H'_5$  is saturated. As before, we first assume that  $H'$  contains an  $s_2 - t_2$  path, and route the remaining flow (i) through  $H'_6$ ,  $q$ ,  $H'_7$ , and  $H'_8$ , and (ii) through  $H'_6$ , an  $s_2 - t_2$  path, and  $H'_9$ , until either the subedgework  $H'_6$ , or the subedgework  $H'_9$  and at least one of the subedgeworks  $H'_7$  and  $H'_8$  become saturated. Since  $r_6^s \leq r/3$ , this requires at most  $r/3 - \tau$  additional units of flow. If  $H'$  does not contain an  $s_2 - t_2$  path, we route the remaining flow only through route (i), until either at least one of the subedgeworks  $H'_7$  and  $H'_8$  or the subedgework  $H'_6$  become saturated. In both cases, the newly saturated subedgeworks, together with the saturated subedgeworks  $H'_1$ ,  $H'_3$ , and  $H'_5$ , form an  $s - t$  cut of saturated subedgeworks, and thus the worst equilibrium bottleneck cost is at least  $r/(3\gamma_2)$ .

Thus, in all cases, we obtain an equilibrium flow with a bottleneck cost of at least  $r/(3\gamma_2)$ . However, in the construction above, the route  $H'_6, q, H'_7, e_2, H'_5, p, H'_9$  may not be simple, since  $p$  and  $q$  may not be vertex-disjoint. If this is the case, this route is technically not allowed by our model, where the flow is only routed through simple  $s - t$  paths. Nevertheless, the corresponding edge flow can be decomposed into the following three simple routes: (i)  $H'_1, e_2$ , and  $H'_3$ , (ii)  $H'_1, e_2, H'_5, p$ , and  $H'_9$ , and (iii)  $H'_6, q, H'_7, e_2$ , and  $H'_3$ , unless  $\min\{r_1^s, r_3^s\} \leq r/3$ . Moreover, if  $\min\{r_1^s, r_3^s\} \leq r/3$ , we can work as above, and saturate both  $H'_1$  and  $H'_3$  with

at most  $r/3$  units of flow. The remaining  $2r/3$  units of flow can be routed (i) through  $H'_6$ ,  $q$ ,  $H'_7$ , and  $H'_8$ , and (ii) through  $H'_4$ ,  $H'_5$ ,  $p$ , and  $H'_9$ , and possibly either through  $H'_6$ , an  $s_2 - t_2$  path<sup>1</sup>, and  $H'_9$ , or through  $H'_4$ ,  $H'_5$ , an  $s_1 - t_1$  path,  $H'_7$ , and  $H'_8$ , until either  $H'_4$  (or  $H'_5$ ) and  $H'_6$ , or  $H'_7$  (or  $H'_8$ ) and  $H'_9$  are saturated. This routing only uses simple routes. In addition, these saturated subedgeworks, together with the saturated subedgeworks  $H'_1$  and  $H'_3$ , form an  $s-t$  cut of saturated subedgeworks, and thus the worst equilibrium bottleneck cost is at least  $r/(3\gamma_2)$ .  $\square$

Propositions 14 and 15 immediately imply part (3) of the lemma, which, in turn, implies part (2).  $\square$

Each time we apply Lemma 11.4 to a  $\gamma$ -gap instance  $G$ , we obtain a  $4\gamma/3$ -gap instance  $G'$  with a number of vertices of at most 8 times the vertices of  $G$  plus the number of vertices of  $D$ . Therefore, if we start with an instance  $\mathcal{I} = (D, s_1, s_2, t_1, t_2)$  of 2-DDP, where  $D$  has  $k$  vertices, and apply Lemma 11.1 once, and subsequently apply Lemma 11.4 for  $\lfloor \log_{4/3} k \rfloor$  times, we obtain a  $k$ -gap instance  $\mathcal{G}'$ , where the network  $G'$  has  $n = O(k^{8 \cdot 23})$  vertices. Suppose now that there is a polynomial-time algorithm  $A$  that approximates the best subnetwork of  $G'$  within a factor of  $O(k^{1-\varepsilon}) = O(n^{0.121-\varepsilon})$ , for some small  $\varepsilon > 0$ . Then, if  $\mathcal{I}$  is a YES-instance of 2-DDP, algorithm  $A$ , applied to  $G'$ , should return a best subnetwork  $H$  with at least one copy of a good subnetwork of  $D$ . Since  $H$  contains a polynomial number of copies of subnetworks of  $D$ , and we can check whether a subnetwork of  $D$  is good in polynomial time, we can efficiently recognize  $\mathcal{I}$  as a YES-instance of 2-DDP. On the other hand, if  $\mathcal{I}$  is a NO-instance of 2-DDP,  $D$  includes no good subnetworks. Again, we can efficiently check that in the subnetwork returned by algorithm  $A$ , there are not any copies of a good subnetwork of  $D$ , and hence recognize  $\mathcal{I}$  as a NO-instance of 2-DDP. Thus, we obtain that:

**Theorem 4.5.** For bottleneck routing games with strictly increasing linear latencies, it is NP-hard to approximate BSubNBC within a factor of  $O(n^{0.121-\varepsilon})$ , for any constant  $\varepsilon > 0$ .

**Remark 4.6.** If in the network  $G$  in the proof of Lemma 11.1 (fig. 11.1) we replace the cost functions  $x$  and  $x/2$  with  $x^d$  and  $x^d/2^d$  respectively, we will get an instance with  $\gamma_1 = 4^d$  and  $\gamma_2 = 3^d$ , and thus  $G$  would be a  $(4/3)^d$ -gap instance. Moreover, if we apply the same techniques as in lemma 11.4, we can amplify the inapproximability gap. As in Lemma 11.4

<sup>1</sup>We note that if the paths  $p$  and  $q$  are not vertex-disjoint, we also have an  $s_1 - t_1$  path and an  $s_2 - t_2$  path in  $H'$ .

we inductively create a new network using as a base the base network of figure 11.1 with cost functions  $x^d$  instead of  $x$  and  $x^d/2^d$  instead of  $x/2$ . In the new network the edges  $e_4, \dots, e_9$  are replaced with a copy of the old network with the known gap  $(4/3)^d$ . Edges  $e_1, e_3$  are replaced with a copy of the old network but with all the cost functions divided by  $2^d$ . This will result to a graph that gives an inapproximability gap of  $(4/3)^{2d}$ . Doing this  $t = \log_{(4/3)^d} n$  times, we result to a network with  $O(n^{\log_{(4/3)^d} 8+1})$  vertices and an inapproximability gap of  $n$ . So, in a similar way like before, we get that (unless  $P=NP$ ), we cannot polynomially approximate BSubNBC within a factor of  $O(n^{1/(\log_{(4/3)^d} 8+1)} - \varepsilon)$

Using  $\alpha^x$  instead of  $x$  and  $\alpha^{x/2}$  instead of  $x/2$  and applying the same technique for say  $t$  times we get a network with gap  $B^*(\mathcal{G})^{(4/3)^t-1}$

## 4.5 Δίκτυα με Σχεδόν Πολυωνυμικά Μονοπάτια

In this section, we approximate, in quasipolynomial-time, the best subnetwork and its worst equilibrium bottleneck cost for instances  $\mathcal{G} = (G, c, r)$  where the network  $G$  has quasipolynomially many  $s - t$  paths, the latency functions are continuous and satisfy a Lipschitz condition, and the worst Nash flow in the best subnetwork routes a non-negligible amount of flow on all used edges.

We highlight that the restriction to networks with quasipolynomially many  $s - t$  paths is somehow necessary, in the sense that Theorem 11.5 shows that if the network has exponentially many  $s - t$  paths, as it happens for the hard instances of 2-DDP, and thus for the networks  $G$  and  $G'$  constructed in the proofs of Lemma 11.1 and Lemma 11.4, it is NP-hard to approximate BSubNBC within any reasonable factor. Also, we can always assume, without loss of generality, that the worst Nash flow of the best subnetwork  $H^*$  assigns positive flow to all edges of  $H^*$ . Otherwise, we can remove any unused edges, without increasing the worst equilibrium bottleneck cost of  $H^*$ . In addition, we assume here that there is a constant  $\delta > 0$ , such that the worst Nash flow in  $H^*$  routes more than  $\delta$  units of flow on all edges of the best subnetwork  $H^*$ .

In the following, we normalize the traffic rate  $r$  to 1. This is for convenience and can be made without loss of generality<sup>2</sup>. Our algorithm is based on [42, Lemma 2], which applies Althöfer's "Sparsification" Lemma

<sup>2</sup>Given a bottleneck routing game  $\mathcal{G}$  with traffic rate  $r > 0$ , we can replace each latency function  $d_e(x)$  with  $d_e(rx)$ , and obtain a bottleneck routing game  $\mathcal{G}'$  with traffic rate 1, and the same Nash flows, PoA, and solutions to BSubNBC.

[5] (similar technique in [60], independently), and shows that any flow can be approximated by a “sparse” flow using logarithmically many paths.

**Lemma 4.7.** Let  $\mathcal{G} = (G(V, E), c, 1)$  be a routing instance, and let  $f$  be any  $\mathcal{G}$ -feasible flow. Then, for any  $\varepsilon > 0$ , there exists a  $\mathcal{G}$ -feasible flow  $\tilde{f}$  using at most  $k(\varepsilon) = \lfloor \log(2m)/(2\varepsilon^2) \rfloor + 1$  paths, such that for all edges  $e$ ,  $|\tilde{f}_e - f_e| \leq \varepsilon$ , if  $f_e > 0$ , and  $\tilde{f}_e = 0$ , otherwise.

By Lemma 11.7, there exists a sparse flow  $\tilde{f}$  that approximates the worst Nash flow  $f$  on the best subnetwork  $H^*$  of  $G$ . Moreover, the proof of [42, Lemma 2] shows that the flow  $\tilde{f}$  is determined by a multiset  $P$  of at most  $k(\varepsilon)$  paths, selected among the paths used by  $f$ . Then, for every path  $p \in \mathcal{P}$ ,  $\tilde{f}_p = |P(p)|/|P|$ , where  $|P(p)|$  is number of times the path  $p$  is included in the multiset  $P$ , and  $|P|$  is the cardinality of  $P$ . Therefore, if the total number  $|\mathcal{P}|$  of  $s - t$  paths in  $G$  is quasipolynomial, we can find, in quasipolynomial-time, by exhaustive search, a flow-subnetwork pair that approximates the optimal solution of BSubNBC. Based on this intuition, we next obtain an approximation algorithm for BSubNBC on networks with quasipolynomially many paths, under the assumption that there is a constant  $\delta > 0$ , such that the worst Nash flow in the best subnetwork  $H^*$  routes more than  $\delta$  units of flow on all edges of  $H^*$ . This assumption is necessary so that the exhaustive search on the family of sparse flows of Lemma 11.7 can generate the best subnetwork  $H^*$ , which is crucial for the analysis.

**Theorem 4.8.** Let  $\mathcal{G} = (G(V, E), c, 1)$  be a bottleneck routing game with continuous latency functions that satisfy the Lipschitz condition with a constant  $\xi > 0$ , let  $H^*$  be the best subnetwork of  $G$ , and let  $f^*$  be the worst Nash flow in  $H^*$ . If for all edges  $e$  of  $H^*$ ,  $f_e^* > \delta$ , for some constant  $\delta > 0$ , then for any constant  $\varepsilon > 0$ , we can compute in time  $|\mathcal{P}|^{O(\log(2m)/\min\{\delta^2, \varepsilon^2/\xi^2\})}$  a flow  $f$  and a subnetwork  $H$  such that: (i)  $f$  is an  $\varepsilon/2$ -Nash flow in the subnetwork  $H$ , (ii)  $B(f) \leq B(H^*, 1) + \varepsilon$ , (iii)  $B(H, 1) \leq B(f) + \varepsilon/4$ , and (iv)  $B(f) \leq B(H, 1) + \varepsilon/2$ .

*Proof.* Let  $\varepsilon > 0$  be a constant, and let  $\varepsilon_1 = \min\{\delta, \varepsilon/(4\xi)\}$ , and  $\varepsilon_2 = \varepsilon/2$ . We show that a flow-subnetwork pair  $(H, f)$  with the desired properties can be computed in time  $|\mathcal{P}|^{O(k(\varepsilon_1))}$ , where  $k(\varepsilon_1) = \lfloor \log(2m)/\min\{2\delta^2, \varepsilon^2/(8\xi^2)\} \rfloor + 1$ . For convenience, we say that a flow  $g$  is a *candidate flow* if there is a multiset  $P$  of paths from  $\mathcal{P}$ , with  $|P| \leq k(\varepsilon_1)$ , such that  $g_p = |P(p)|/|P|$ , for each  $p \in \mathcal{P}$ . Namely, a candidate flow belongs to the family of sparse flows, which by Lemma 11.7, can approximate any other flow. Similarly, a subnetwork  $H$  is a *candidate subnetwork* if there is a candidate flow  $g$  such that  $H$  consists of the edges used by  $g$  (and only of them), and a

subnetwork-flow pair  $(H, g)$  is a *candidate solution*, if  $g$  is a candidate flow,  $H$  is a candidate subnetwork that includes all the edges used by  $g$  (and possibly some other edges), and  $g$  is an  $\epsilon_2$ -Nash flow in  $H$ .

By exhaustive search, in time  $|\mathcal{P}|^{O(k(\epsilon_1))}$ , we generate all candidate flows, all candidate subnetworks, and compute the bottleneck cost  $B(g)$  of any candidate flow  $g$ . Then, for each pair  $(H, g)$ , where  $g$  is a candidate flow and  $H$  is a candidate subnetwork, we check, in polynomial time, whether  $g$  is an  $\epsilon_2$ -Nash flow in  $H$ , and thus whether  $(H, g)$  is a candidate solution. Thus, in time  $|\mathcal{P}|^{O(k(\epsilon_1))}$ , we determine all candidate solutions. For each candidate subnetwork  $H$  that participates in at least one candidate solution, we let  $\tilde{B}(H)$  be the maximum bottleneck cost  $B(g)$  of a candidate flow  $g$  for which  $(H, g)$  is a candidate solution. The algorithm returns the subnetwork  $H$  that minimizes  $\tilde{B}(H)$ , and a flow  $f$  for which  $(H, f)$  is a candidate solution and  $\tilde{B}(H) = B(f)$ .

The exhaustive search above can be implemented in  $|\mathcal{P}|^{O(k(\epsilon_1))}$  time. As for the properties of the solution  $(H, f)$ , the definition of candidate solutions immediately implies (i), i.e., that  $f$  is an  $\epsilon/2$ -Nash flow in  $H$ .

In the following we use Lemma 11.7, and show (ii), (iii), and (iv).

We first show (ii), i.e., that  $B(f) \leq B(H^*, 1) + \epsilon$ . We recall that  $H^*$  denotes the best subnetwork of  $\mathcal{G}$  and  $f^*$  denotes the worst Nash flow in  $H^*$ . Also, by hypothesis,  $f_e^* > \delta > 0$ , for all edges  $e$  of  $H^*$ .

By Lemma 11.7, there is a candidate flow  $\tilde{f}$  such that for all edges  $e$  of  $H^*$ ,  $|\tilde{f}_e - f_e^*| \leq \epsilon_1$ . Thus, since  $\epsilon_1 \leq \delta$ ,  $H^*$  is a candidate network, because  $\tilde{f}_e > 0$  for all edges  $e$  of  $H^*$ . Moreover, by the Lipschitz condition and the choice of  $\epsilon_1$ , for all edges  $e$  of  $H^*$ ,  $|d_e(\tilde{f}) - d_e(f_e^*)| \leq \epsilon/4$ . Therefore, since  $f^*$  is a Nash flow in  $H^*$ ,  $\tilde{f}$  is an  $\epsilon_2$ -Nash flow in  $H^*$ , and thus  $(H, \tilde{f})$  is a candidate solution. Furthermore,  $|B(\tilde{f}) - B(f^*)| \leq \epsilon/4$ , i.e., the bottleneck cost of  $\tilde{f}$  is within an additive term of  $\epsilon/4$  from the worst equilibrium bottleneck cost of  $H^*$ . In particular,  $B(\tilde{f}) \leq B(H^*, 1) + \epsilon/4$ .

We also need to show that for any other candidate flow  $g$  for which  $(H^*, g)$  is a candidate solution,  $B(g) \leq B(\tilde{f}) + 3\epsilon/4$ , and thus  $\tilde{B}(H^*) \leq B(\tilde{f}) + 3\epsilon/4 \leq B(H^*, 1) + \epsilon$ . To reach a contradiction, let us assume that there is a candidate flow  $g$  that is an  $\epsilon_2$ -Nash flow in  $H^*$  and has  $B(g) > B(\tilde{f}) + 3\epsilon/4$ . But then, we should expect that there is a Nash flow  $g'$  in  $H^*$  that closely approximates  $g$  and has a bottleneck cost of  $B(g') \approx B(g) > B(f^*)$ , a contradiction. Formally, since  $g$  is an  $\epsilon_2$ -Nash flow in  $H^*$ , the set of edges with  $d_e(g_e) \geq B(g) - \epsilon/2$  comprises an  $s - t$  cut in  $H^*$ . Then, by the continuity of the latency functions, we can fix a part of the flow routed essentially as in  $g$ , so that there is an  $s - t$  cut consisting of used edges with latency  $B(g) - \epsilon/2$ , and possibly unused edges with latency at least  $B(g) - \epsilon/2$ , and reroute the remaining flow on top of it, so that we obtain a



Nash flow  $g'$  in  $H^*$ . But then,

$$B(g') \geq B(g) - \varepsilon/2 > B(\tilde{f}) + \varepsilon/4 \geq B(f^*),$$

which contradicts the hypothesis that  $f^*$  is the worst Nash flow in  $H^*$ .

Therefore,  $\tilde{B}(H^*) \leq B(H^*, 1) + \varepsilon$ . Since the algorithm returns the candidate solution  $(H, f)$ , and not a candidate solution including  $H^*$ ,  $\tilde{B}(H) \leq B(H^*)$ . Thus, we obtain (ii), namely that  $\tilde{B}(H) = B(f) \leq B(H^*, 1) + \varepsilon$ .

We proceed to show (iii), namely that  $B(H, 1) \leq B(f) + \varepsilon/4$ . To this end, we let  $g$  be the worst Nash flow in  $H$ . By Lemma 11.7, there is a candidate flow  $\tilde{g}$  such that for all edges  $e$  of  $H$ ,  $|\tilde{g}_e - g_e| \leq \varepsilon_1$ , if  $g_e > 0$ , and  $\tilde{g}_e = 0$ , otherwise. Therefore, by the Lipschitz condition and the choice of  $\varepsilon_1$ , for all edges  $e$  of  $H$ ,  $|d_e(\tilde{g}_e) - d_e(g_e)| \leq \varepsilon/4$ , if  $g_e > 0$ , and  $d_e(\tilde{g}_e) = d_e(g_e) = 0$ , otherwise. This implies that  $|B(\tilde{g}) - B(g)| \leq \varepsilon/4$ , i.e., that bottleneck cost of  $\tilde{g}$  is within an additive term of  $\varepsilon/4$  from the bottleneck cost of  $g$ . In particular,  $B(g) \leq B(\tilde{g}) + \varepsilon/4$ .

We also need to show that  $(H, \tilde{g})$  is a candidate solution. Since  $H$  is a candidate subnetwork and  $\tilde{g}$  is a candidate flow, we only need to show that  $\tilde{g}$  is an  $\varepsilon_2$ -Nash flow in  $H$ . Since  $g$  is a Nash flow in  $H$ , the set of edges  $C = \{e : d_e(g_e) \geq B(g)\}$  comprises an  $s - t$  cut in  $H$ . In fact, for all edges  $e \in C$ ,  $d_e(g_e) = B(g)$ , if  $g_e > 0$ , and  $d_e(g_e) \geq B(g)$ , otherwise. Let us now consider the latency in  $\tilde{g}$  of each edge  $e \in C$ . If  $g_e = 0$ , then  $d_e(\tilde{g}_e) = d_e(g_e) \geq B(g) \geq B(\tilde{g}) - \varepsilon/4$ . If  $g_e > 0$ , then

$$B(\tilde{g}) \geq d_e(\tilde{g}_e) \geq d_e(g_e) - \varepsilon/4 = B(g) - \varepsilon/4 \geq B(\tilde{g}) - \varepsilon/2.$$

Therefore, for the flow  $\tilde{g}$ , we have an  $s - t$  cut in  $H$  consisting of edges  $e$  either with  $\tilde{g}_e > 0$  and  $B(\tilde{g}) - \varepsilon/2 \leq d_e(\tilde{g}_e) \leq B(\tilde{g})$ , or with  $\tilde{g}_e = 0$  and  $d_e(\tilde{g}_e) \geq B(\tilde{g}) - \varepsilon/4$ . By the standard properties of  $\varepsilon$ -Nash flows (see also in Section 11.1), we obtain that  $\tilde{g}$  is a  $\varepsilon_2$ -Nash flow in  $H$ .

Hence, we have shown that  $(H, \tilde{g})$  is a candidate solution, and that  $B(g) \leq B(\tilde{g}) + \varepsilon/4$ . Therefore, the algorithm considers both candidate solutions  $(H, f)$  and  $(H, \tilde{g})$ , and returns  $(H, f)$ , which implies that  $B(\tilde{g}) \leq B(f)$ . Thus, we obtain (iii), namely that  $B(H, 1) = B(g) \leq B(f) + \varepsilon/4$ .

To conclude the proof, we next show (iv), namely that  $B(f) \leq B(H, 1) + \varepsilon/2$ . For the proof, we use the same notation as in (iii). The argument is essentially identical to that used in the second part of the proof of (ii). More specifically, to reach a contradiction, we assume that the candidate flow  $f$ , which is an  $\varepsilon_2$ -Nash flow in  $H$ , has  $B(f) > B(H, 1) + \varepsilon/2$ . Then, as before, we should expect that there is a Nash flow  $f'$  in  $H$  that approximates  $f$  and has a bottleneck cost of  $B(f') \approx B(f) > B(H, 1)$ , a contradiction. Formally, since

$f$  is an  $\varepsilon_2$ -Nash flow in  $H$ , the set of edges with  $d_e(f_e) \geq B(f) - \varepsilon/2$  comprises an  $s - t$  cut in  $H$ . Then, by the continuity of the latency functions, we can fix a part of the flow routed essentially as in  $f$ , so that there is an  $s - t$  cut consisting of used edges with latency  $B(f) - \varepsilon/2$ , and possibly unused edges with latency at least  $B(f) - \varepsilon/2$ , and reroute the remaining flow on top of it, so that we obtain a Nash flow  $f'$  in  $H$ . But then,  $B(f') \geq B(f) - \varepsilon/2 > B(H, 1)$ , which contradicts the definition of the worst equilibrium bottleneck cost  $B(H, 1)$  of  $H$ . Thus, we obtain (iv), namely that  $B(f) \leq B(H, 1) + \varepsilon/2$ .  $\square$

Therefore, the algorithm of Theorem 12.1 returns a flow-subnetwork pair  $(H, f)$  such that  $f$  is an  $\varepsilon/2$ -Nash flow in  $H$ , the worst equilibrium bottleneck cost of the subnetwork  $H$  approximates the worst equilibrium bottleneck cost of  $H^*$ , since  $B(H^*, 1) \leq B(H, 1) \leq B(H^*, 1) + 5\varepsilon/4$ , by (ii) and (iii), and the bottleneck cost of  $f$  approximates the worst equilibrium bottleneck cost of  $H$ , since  $B(H, 1) - \varepsilon/4 \leq B(f) \leq B(H, 1) + \varepsilon/2$ , by (iii) and (iv).

## Κεφάλαιο 5

# Παράδοξο του Μπράες σε Τυχαίες Φύσης Δίκτυα με Προσθετικά Κόστη

Στο κεφάλαιο αυτό εξετάζουμε την προσεγγισιμότητα του προβληματος εύρεσης βέλτιστου υποδικτύου για την κλάση των τυχαίων *Erdos – Renyi*  $\mathcal{G}_{n,p}$  γράφων που έχουν αποδειχθεί επιρρεπείς στο παράδοξο (*Roughgarden* και *Valiant*, *RSA* 2010) και (*Chung* και *Young*, *WINE* 2010). Η βασική μας συνεισφορά είναι μια πολυωνυμικού χρόνου αναγωγή που διαφυλάσσει τους παράγοντες προσέγγισης για το από το πρόβλημα σε τέτοια τυχαία δίκτυα στο πρόβλημα σε είναι απλοποιημένοπ δίκτυο όπου όλοι οι γείτονες του  $s$  και του  $t$  είναι απευθείας συνδεδεμένοι από ακμές 0 κόστους. Βασιζόμενοι σε αυτό, φτιάχνουμε ένα πολυωνυμικό σχήμα για κάθε  $\varepsilon > 0$  που με μεγάλη πιθανότητα, υπολογίζει ένα υποδίκτυο με την  $\varepsilon$ -Nash ισορροπία να κοστίζει το πολύ  $(1 + \varepsilon)L^* + \varepsilon$ , όπου το  $L^*$  είναι η καθυστέρηση στο βέλτιστο δίκτυο. Το προσεγγιστικό σχήμα μας τρέχει σε πολυωνυμικό χρόνο αν το τυχαίο δίκτυο έχει μέσο βαθμό  $O(\text{poly}(\ln n))$  και η συνολική κίνηση μέσα στο δίκτυο είναι  $O(\text{poly}(\ln \ln n))$ , και είναι σχεδόν πολυωνυμικό για μέσους βαθμούς μέχρι  $o(n)$  και συνολική κίνηση ίση με  $O(\text{poly}(\ln n))$ .

### 5.1 Ορισμοί που αφορούν το Συγκεκριμένο Πρόβλημα

We deal with a typical instance  $(G(V, E), (d_e)_{e \in E}, r)$  of a non atomic CG (*selfish routing game*). In such instances, as noted earlier, all used paths under a Nash flow have a unique minimum latency which we denote as  $L(G, d, r)$  or  $L(G, r)$ , for brevity, assuming that the latency function are given within  $G$ .

The paradox seems not an artifact of optimization theory [56, 77], and our motivation is whether in some practically interesting settings, where

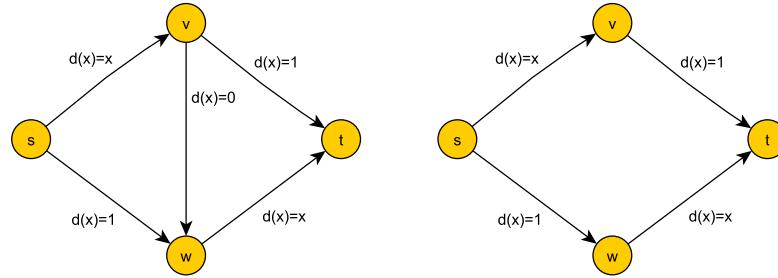

**Figure 5.1:**

(a) The optimal total latency social cost is  $3/2$ , achieved by routing half of the flow on each of the paths  $(s, v, t)$  and  $(s, w, t)$ . In the Nash flow, all traffic goes through the path  $(s, v, w, t)$  and has selfish cost  $2$ , thus inducing the *worst* PoA =  $4/3$  for linear latencies. (b) If we remove the edge  $(v, w)$ , the Nash flow coincides with the optimal social flow. Hence the network (b) is the *best subnetwork* of network (a) and achieves the *best possible* PoA =  $1$ , with no sacrificed players through slower paths.

the paradox occurs, we can efficiently compute a set of edges whose removal significantly improves the equilibrium latency.

We only consider linear latencies  $d_e(x) = a_e x + b_e$ , with  $a_e, b_e \geq 0$ . We restrict our attention to instances where the coefficients  $a_e$  and  $b_e$  are randomly selected from a pair of random variables  $\mathcal{A}$  and  $\mathcal{B}$ . Following [24, 84], we say that  $\mathcal{A}$  and  $\mathcal{B}$  are *reasonable* if:

- $\mathcal{A}$  has bounded range  $[A_{\min}, A_{\max}]$  and  $\mathcal{B}$  has bounded range  $[0, B_{\max}]$ , where  $A_{\min} > 0$  and  $A_{\max}, B_{\max}$  are constants, i.e., they do not depend on  $r$  and  $|V|$ .
- There is a closed interval  $I_{\mathcal{A}}$  of positive length, such that for every non-trivial subinterval  $I' \subseteq I_{\mathcal{A}}$ ,  $\Pr[\mathcal{A} \in I'] > 0$ .
- There is a closed interval  $I_{\mathcal{B}}$ ,  $0 \in I_{\mathcal{B}}$ , of positive length, such that for every non-trivial subinterval  $I' \subseteq I_{\mathcal{B}}$ ,  $\Pr[\mathcal{B} \in I'] > 0$ . Moreover, for any constant  $\eta > 0$ , there exists a constant  $\delta_{\eta} > 0$ , such that  $\Pr[\mathcal{B} \leq \eta] \geq \delta_{\eta}$ .

**Flows and Nash Flows.** Two flows  $f$  and  $g$  are *different* if there is an edge  $e$  with  $f_e \neq g_e$ .

Given a flow  $f$ , let the latency of  $f$  be  $L(f) = \max_{p: f_p > 0} d_p(f)$ . We sometimes write  $L_G(f)$  when the network  $G$  is not clear from the context.

For an instance  $(G(V, E), r)$  and a flow  $f$ , we let  $E_f = \{e \in E : f_e > 0\}$  be the set of edges used by  $f$ , and  $G_f(V, E_f)$  be the corresponding subnetwork of  $G$ . In a Nash flow  $f$ , all players incur a common latency on their paths, which, according to the previous definitions, is  $L(f) = \min_p d_p(f) = \max_{p: f_p > 0} d_p(f)$ . A Nash flow  $f$  on a network  $G(V, E)$  is a Nash flow on any subnetwork  $G'(V', E')$  of  $G$  with  $E_f \subseteq E'$ .

Every instance  $(G, r)$  admits at least one Nash flow, and the players' latency is the same for all Nash flows (see e.g., [77]). For linear latency functions, a Nash flow can be computed efficiently, in strongly polynomial time, while for strictly increasing latencies, the Nash flow is essentially unique (see e.g., [77]).

**Best Subnetwork.** Recall, the *best subnetwork*  $H^*$  of  $(G, r)$  is a subnetwork of  $G$  with the minimum equilibrium latency, i.e.,  $H^*$  has  $L(H^*, r) \leq L(H, r)$  for any subnetwork  $H$  of  $G$ . We study the approximability of the *Best Subnetwork Equilibrium Latency* problem, or BestSubEL in short. In BestSubEL, we are given an instance  $(G, r)$ , and seek for the best subnetwork  $H^*$  of  $(G, r)$  and its equilibrium latency  $L(H^*, r)$ .

**Good Networks.** We restrict our attention to undirected  $s - t$  networks  $G(V, E)$ . We let  $n \equiv |V|$  and  $m \equiv |E|$ . For any vertex  $v$ , we let  $\Gamma(v) = \{u \in V : \{u, v\} \in E\}$  denote the set of  $v$ 's neighbors in  $G$ . Similarly, for any non-empty  $S \subseteq V$ , we let  $\Gamma(S) = \bigcup_{v \in S} \Gamma(v)$  denote the set of neighbors of the vertices in  $S$ , and let  $G[S]$  denote the subnetwork of  $G$  induced by  $S$ . For convenience, we let  $V_s \equiv \Gamma(s)$ ,  $E_s \equiv \{\{s, u\} : u \in V_s\}$ ,  $V_t \equiv \Gamma(t)$ ,  $E_t \equiv \{\{v, t\} : v \in V_t\}$ , and  $V_m \equiv V \setminus (\{s, t\} \cup V_s \cup V_t)$ . We also let  $n_s = |V_s|$ ,  $n_t = |V_t|$ ,  $n_+ = \max\{n_s, n_t\}$ ,  $n_- = \min\{n_s, n_t\}$ , and  $n_m = |V_m|$ . We sometimes write  $V(G)$ ,  $n(G)$ ,  $V_s(G)$ ,  $n_s(G)$ ,  $\dots$ , if  $G$  is not clear from the context.

It is convenient to think that the network  $G$  has a layered structure consisting of  $s$ , the set of  $s$ 's neighbors  $V_s$ , an “intermediate” subnetwork connecting the neighbors of  $s$  to the neighbors of  $t$ , the set of  $t$ 's neighbors  $V_t$ , and  $t$ . Then, any  $s - t$  path starts at  $s$ , visits some  $u \in V_s$ , proceeds either directly or through some vertices of  $V_m$  to some  $v \in V_t$ , and finally reaches  $t$ . Thus, we refer to  $G_m \equiv G[V_s \cup V_m \cup V_t]$  as the *intermediate subnetwork* of  $G$ . Depending on the structure of  $G_m$ , we say that:

- $G$  is a *random*  $\mathcal{G}_{n,p}$  network if (i)  $n_s$  and  $n_t$  follow the binomial distribution with parameters  $n$  and  $p$ , and (ii) if any edge  $\{u, v\}$ , with  $u \in V_m \cup V_s$  and  $v \in V_m \cup V_t$ , exists independently with probability  $p$ . Namely, the intermediate network  $G_m$  is an Erdős-Rényi random graph with  $n - 2$  vertices and edge probability  $p$ , except for the fact that there are no edges in  $G[V_s]$  and in  $G[V_t]$ .

- $G$  is *internally bipartite* if the intermediate network  $G_m$  is a bipartite graph with independent sets  $V_s$  and  $V_t$ .  $G$  is *internally complete bipartite* if every neighbor of  $s$  is directly connected by an edge to every neighbor of  $t$ .
- $G$  is *0-latency simplified* if it is internally complete bipartite and every edge  $e$  connecting a neighbor of  $s$  to a neighbor of  $t$  has latency function  $d_e(x) = 0$ .

The *0-latency simplification*  $G_0$  of a given network  $G$  is a 0-latency simplified network obtained from  $G$  by replacing  $G[V_m]$  with a set of 0-latency edges directly connecting every neighbor of  $s$  to every neighbor of  $t$ . Moreover, we say that a 0-latency simplified network  $G$  is *balanced*, if  $|n_s - n_t| \leq 2n$ .

We say that a network  $G(V, E)$  is  $(n, p, k)$ -good, for some integer  $n \leq |V|$ , some probability  $p \in (0, 1)$ , with  $pn = o(n)$ , and some constant  $k \geq 1$ , if  $G$  satisfies that:

1. The maximum degree of  $G$  is at most  $3np/2$ , i.e., for any  $v \in V$ ,  $|\Gamma(v)| \leq 3np/2$ .
2.  $G$  is an *expander graph*, namely, for any set  $S \subseteq V$ ,  $|\Gamma(S)| \geq \min\{np|S|, n\}/2$ .
3. The edges of  $G$  have random reasonable latency functions distributed according to  $\mathcal{A} \times \mathcal{B}$ , and for any constant  $\eta > 0$ ,  $\Pr[\mathcal{B} \leq \eta/\ln n]np = \omega(1)$ .
4. If  $k > 1$  and we randomly partition  $V_m$  into  $k$  sets  $V_m^1, \dots, V_m^k$ , each of cardinality  $|V_m|/k$ , all the induced subnetworks  $G[\{s, t\} \cup V_s \cup V_m^i \cup V_t]$  are  $(n/k, p, 1)$ -good, with a possible violation of the maximum degree bound by  $s$  and  $t$ .

If  $G$  is a *random*  $\mathcal{G}_{n,p}$  network, with  $n$  sufficiently large and  $p \geq ck \ln n/n$ , for some large enough constant  $c > 1$ , then  $G$  is a  $(n, p, k)$ -good network with high probability (see e.g., [15]), provided that the latency functions satisfy condition (3) above. Similarly, the random instances considered in [24] are good with high probability. Also note that the 0-latency simplification of a good network is balanced, due to (1) and (2).

## 5.2 Το σχήμα Προσέγγισης και το Περίγραμμα της Ανάλυσης

In this section, we describe the main steps of the approximation scheme (see also Algorithm 1), and give an outline of its analysis. We let  $\varepsilon > 0$  be the approximation guarantee, and assume that  $L(G, r) \geq \varepsilon$ . Otherwise, any Nash flow of  $(G, r)$  suffices.

---

### Algorithm 1: Approximation Scheme for BestSubEL in Good Networks

---

**Input:** Good network  $G(V, E)$ , rate  $r > 0$ , approximation guarantee  $\varepsilon > 0$

**Output:** Subnetwork  $H$  of  $G$  and  $\varepsilon$ -Nash flow  $g$  in  $H$  with

$$L(g) \leq (1 + \varepsilon)L(H^*, r) + \varepsilon$$

- 1 if  $L(G, r) < \varepsilon$ , return  $G$  and a Nash flow of  $(G, r)$  ;
  - 2 create the 0-latency simplification  $G_0$  of  $G$  ;
  - 3 if  $r \geq (B_{\max} n_+) / (\varepsilon A_{\min})$ , then let  $H_0 = G_0$  and let  $f$  be a Nash flow of  $(G_0, r)$  ;
  - 4 else, let  $H_0$  be the subnetwork and  $f$  the  $\varepsilon/6$ -Nash flow of Thm. 12.7 applied with error  $\varepsilon/6$  ;
  - 5 let  $H$  be the subnetwork and let  $g$  be the  $\varepsilon$ -Nash flow of Lemma 12.9 starting from  $H_0$  and  $f$  ;
  - 6 return the subnetwork  $H$  and the  $\varepsilon$ -Nash flow  $g$  ;
- 

Algorithm 1 is based on an approximation-preserving reduction of BestSubEL for a good network  $G$  to BestSubEL for the 0-latency simplification  $G_0$  of  $G$ . The first step of our approximation-preserving reduction is to show that the equilibrium latency of the best subnetwork does not increase when we consider the 0-latency simplification  $G_0$  of a network  $G$  instead of  $G$  itself. Since decreasing the edge latencies (e.g., decreasing  $d_{(v,w)}(x) = 1$  to  $d_{(v,w)}(x) = 0$  in Fig. 12.1.a) may trigger Braess's paradox, we need Lemma 12.2 and its careful proof to make sure that zeroing out the latency of the intermediate subnetwork does not cause an abrupt increase in the equilibrium latency.

Next, we focus on the 0-latency simplification  $G_0$  of  $G$  (step 2 in Alg. 1). We show that if the traffic rate is large enough, i.e., if  $r = \Omega(n_+/\varepsilon)$ , the paradox has a marginal influence on the equilibrium latency. Thus, any Nash flow of  $(G_0, r)$  is an  $(1 + \varepsilon)$ -approximation of BestSubEL (Lemma 12.3, step 4). If  $r = O(n_+/\varepsilon)$ , we use an approximate version of Caratheodory's theorem (Theorem 12.6) to prove that by an efficient exhaustive search we can obtain an  $\varepsilon/6$ -approximation of BestSubEL for  $(G_0, r)$  (Theorem 12.7,

step 4), which in fact we obtain!

We now have a subnetwork  $H_0$  and an  $\varepsilon/6$ -Nash flow  $f$  that comprise a good approximate solution to BestSubEL for the simplified instance  $(G_0, r)$ . The next step of our approximation-preserving reduction is to extend  $f$  to an approximate solution to BestSubEL for the original instance  $(G, r)$ . The intuition is that due to the expansion and the reasonable latencies of  $G$ , any collection of 0-latency edges of  $H_0$  used by  $f$  to route flow from  $V_s$  to  $V_t$  can be “simulated” by an appropriate collection of low-latency paths of the intermediate subnetwork  $G_m$  of  $G$ . We first prove this claim for a small part of  $H_0$  consisting only of neighbors of  $s$  and neighbors of  $t$  with approximately the same latency under  $f$  (Lemma 12.8, the proof draws ideas from [24, Lemma 5]). Then, using a careful latency-based grouping of the neighbors of  $s$  and of the neighbors of  $t$  in  $H_0$ , we extend this claim to the entire  $H_0$  (Lemma 12.9). Thus, we obtain a subnetwork  $H$  of  $G$  and an  $\varepsilon$ -Nash flow  $g$  in  $H$  such that  $L(g) \leq (1 + \varepsilon)L(H^*, r) + \varepsilon$  (step 5).

We summarize our main result. The proof follows by combining Lemma 12.2, Theorem 12.7, and Lemma 12.9 in the way indicated by Algorithm 1 and the discussion above.

**Theorem 5.1.** Let  $G(V, E)$  be  $(n, p, k)$ -good network, where  $k \geq 1$  is a large enough constant, let  $r > 0$  be any traffic rate, and let  $H^*$  be the best subnetwork of  $(G, r)$ . Then, for any  $\varepsilon > 0$ , Algorithm 1 computes in time  $n_+^{O(r^2 A_{\max}^2 / \varepsilon^2)} \text{poly}(|V|)$ , a flow  $g$  and a subnetwork  $H$  of  $G$  such that with high probability, wrt. the random choice of the latency functions,  $g$  is an  $\varepsilon$ -Nash flow of  $(H, r)$  and has  $L(g) \leq (1 + \varepsilon)L(H^*) + \varepsilon$ .

By the definition of reasonable latencies,  $A_{\max}$  is a constant. Also, by Lemma 12.3,  $r$  affects the running time only if  $r = O(n_+ / \varepsilon)$ . In fact, previous work on selfish network design assumes that  $r = O(1)$ , see e.g., [77]. Thus, if  $r = O(1)$  (or more generally, if  $r = O(\text{poly}(\ln \ln n))$ ) and  $pn = O(\text{poly}(\ln n))$ , in which case  $n_+ = O(\text{poly}(\ln n))$ , Theorem 12.1 gives a randomized polynomial-time approximation scheme for BestSubEL in good networks. Moreover, the running time is quasipolynomial for traffic rates up to  $O(\text{poly}(\ln n))$  and average degrees up to  $o(n)$ , i.e., for the entire range of  $p$  in [24, 84]. The next sections are devoted to the proofs of Lemmas 12.2 and 12.9, and of Theorem 12.7.

### 5.3 Απλοποίηση του δικτύου

We first show that the equilibrium latency of the best subnetwork does not increase when we consider the 0-latency simplification  $G_0$  of a network  $G$



instead of  $G$  itself.

**Lemma 5.2.** Let  $G$  be any network, let  $r > 0$  be any traffic rate, and let  $H$  be the best subnetwork of  $(G, r)$ . Then, there is a subnetwork  $H'$  of the 0-latency simplification of  $H$  (and thus, a subnetwork of  $G_0$ ) with  $L(H', r) \leq L(H, r)$ .

*Proof.* Throughout the proof, we assume wlog. that all the edges of  $H$  are used by the equilibrium flow  $f$  of  $(H, r)$  (otherwise, we can remove all unused edges from  $H$ ). The proof is constructive, and at the conceptual level, proceeds in two steps.

For the first step, given the equilibrium flow  $f$  of the best subnetwork  $H$  of  $G$ , we construct a simplification  $H_1$  of  $H$  that is internally bipartite and has constant latency edges connecting  $\Gamma(s)$  to  $\Gamma(t)$ .  $H_1$  also admits  $f$  as an equilibrium flow, and thus  $L(H_1, r) = L(H, r)$ . We also show how to further simplify  $H_1$  so that its intermediate bipartite subnetwork becomes acyclic.

To construct the simplification  $H_1$  of  $H$ , we let  $f$  be the equilibrium flow of  $H$ , and let  $L \equiv L(H, r)$ . For each  $u_i \in \Gamma(s)$  and  $v_j \in \Gamma(t)$ , we let  $f_{ij} = \sum_{p=(s, u_i, \dots, v_j, t)} f_p$  be the flow routed by  $f$  from  $u_i$  to  $v_j$ . The network  $H_1$  is obtained from  $H$  by replacing the intermediate subnetwork of  $H$  with a bipartite subnetwork connecting  $\Gamma(s)$  and  $\Gamma(t)$  with constant latency edges. More specifically, instead of the intermediate subnetwork of  $H$ , for each  $u_i \in \Gamma(s)$  and  $v_j \in \Gamma(t)$  with  $f_{ij} > 0$ , we have an edge  $\{u_i, v_j\}$  of constant latency  $b_{ij} = L - (a_{\{s, u_i\}} f_{\{s, u_i\}} + b_{\{s, u_i\}}) - (a_{\{v_j, t\}} f_{\{v_j, t\}} + b_{\{v_j, t\}})$  (the corresponding  $a_{ij}$  is set to 0). If  $f_{ij} = 0$ ,  $u_i$  and  $v_j$  are not connected in  $H_1$ . We note that by construction,  $H_1$  admits  $f$  as an equilibrium flow, and thus  $L(H_1, r) = L$ .

Furthermore, we modify  $H_1$  by deleting some edges from its intermediate subnetwork so that the induced bipartite subgraph  $H_1[\Gamma(s) \cup \Gamma(t)]$  becomes acyclic. Therefore, in the resulting network, for each  $u_i \in \Gamma(s)$  and each  $v_j \in \Gamma(t)$ , there is at most one  $(s, u_i, v_j, t)$  path in  $H_1$ . Hence, the resulting network admits a unique equilibrium flow with a unique path decomposition.

To this end, let us assume that there is a cycle  $C = (u_1, v_2, u_2, \dots, v_k, u_k, v_1, u_1)$  in the intermediate subnetwork  $H_1[\Gamma(s) \cup \Gamma(t)]$ . We let  $e_{k1} = \{u_k, v_1\}$  be the edge of  $C$  with the minimum amount of flow in  $f$ , and let  $f_{k1}$  be the flow through  $e_{k1}$  (see also Fig. 12.2). Then, removing  $e_{k1}$ , and updating the flows along the remaining edges of  $C$  so that  $f'_{ii} = f_{ii} + f_{k1}$ ,  $1 \leq i \leq k$ , and  $f'_{i(i+1)} = f_{i(i+1)} - f_{k1}$ ,  $1 \leq i \leq k - 1$ , we “break” the cycle  $C$ , by eliminating the flow in  $e_{k1}$ , and obtain a new equilibrium flow  $f'$  of the same rate  $r$  and with the same latency  $L$  as that of  $f$ . Applying this procedure repeatedly to all cycles, we end up with an internally bipartite network  $H_1$  with an acyclic

intermediate subnetwork that includes constant latency edges only. Moreover,  $H_1$  admits an equilibrium flow  $f$  of latency  $L$ . This concludes the first part of the proof.

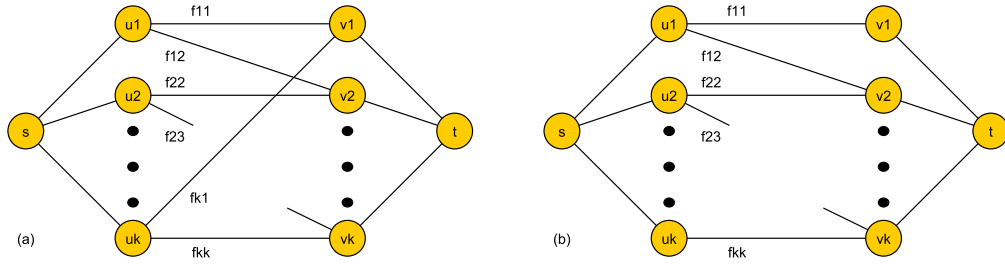

**Figure 5.2:** In (a), we have a cycle  $C = (u_1, v_2, u_2, \dots, v_k, u_k, v_1, u_1)$  in the intermediate subnetwork  $H_1[\Gamma(s) \cup \Gamma(t)]$ . We assume that  $f_{kl}$  is the minimum amount flow through an edge of  $C$  in the equilibrium flow  $f$ . In (b), we have removed the edge  $e_{kl}$ , and show the corresponding change in the amount of flow on the remaining edges of  $C$ . Since the latency functions of the edges in  $C$  are constant, the change in the flow does not affect equilibrium.

The second part of the proof is to show that we can either remove some of the intermediate edges of  $H_1$  or zero their latencies, and obtain a subnetwork  $H'$  of the 0-latency simplification of  $H$  with  $L(H', r) \leq L(H, r)$ . To this end, we describe a procedure where in each step, we either remove some intermediate edge of  $H_1$  or zero its latency, without increasing the latency of the equilibrium flow.

Let us focus on an edge  $e_{kl} = \{u_k, v_l\}$  with  $b_{kl} > 0$ , and attempt to set its latency function to  $b'_{kl} = 0$ . We have also to change the equilibrium flow  $f$  to a new flow  $f'$  that is an equilibrium flow of latency at most  $L$  in the modified network with  $b'_{kl} = 0$ . We let  $r_p$  be the amount of flow moving from an  $s - t$  path  $p = (s, u_i, v_j, t)$  to the path  $p_{kl} = (s, u_k, v_l, t)$  during this change. We note that  $r_p$  may be negative, in which case,  $|r_p|$  units of flow actually move from  $p_{kl}$  to  $p$ . Thus,  $r_p$ 's define a rerouting of  $f$  to a new flow  $f'$ , with  $f'_p = f_p - r_p$ , for any  $s - t$  path  $p$  other than  $p_{kl}$ , and  $f'_{kl} = f_{kl} + \sum_p r_p$ .

Next, we show how to compute  $r_p$ 's so that  $f'$  is an equilibrium flow of cost at most  $L$  in the modified network (where we want to set  $b'_{kl} = 0$ ). We let  $\mathcal{P} = \mathcal{P}_{H_1} \setminus \{p_{kl}\}$  denote the set of all  $s - t$  paths in  $H_1$  other than  $p_{kl}$ . We let  $\bar{F}$  be the  $|\mathcal{P}| \times |\mathcal{P}|$  matrix, indexed by the paths  $p \in \mathcal{P}$ , where  $\bar{F}[p_1, p_2] = \sum_{e \in p_1 \cap p_2} a_e - \sum_{e \in p_1 \cap p_{kl}} a_e$ , and let  $\bar{r}$  be the vector of  $r_p$ 's. Then, the  $p$ -th component of  $\bar{F}\bar{r}$  is equal to  $d_p(f) - d_p(f')$ . In the following, we consider two cases depending on whether  $\bar{F}$  is singular or not.

If  $\bar{F}$  is non-singular, the linear system  $\bar{F}\bar{r} = \varepsilon \bar{1}$  has a unique solution

$\bar{r}_\varepsilon$ , for any  $\varepsilon > 0$ . Moreover, due to linearity, for any  $a \geq 0$ , the unique solution of the system  $\bar{F}\bar{r} = a\varepsilon\bar{1}$  is  $a\bar{r}_\varepsilon$ . Therefore, for an appropriately small  $\varepsilon > 0$ , the linear system  $\mathcal{Q}_\varepsilon = \{\bar{F}\bar{r} = \varepsilon\bar{1}, f_p - r_p \geq 0 \ \forall p \in \mathcal{P}, f_{kl} + \sum_p r_p \geq 0, d_{p_{kl}}(f') \leq L + b_{kl} - \varepsilon\}$  admits a unique solution  $\bar{r}$ . We keep increasing  $\varepsilon$  until one of the inequalities of  $\mathcal{Q}_\varepsilon$  becomes tight. If it first becomes  $r_p = f_p$  for some path  $p = (s, u_i, v_j, t) \in \mathcal{P}$ , we remove the edge  $\{u_i, v_j\}$  from  $H_1$  and adjust the constant latency of  $e_{kl}$  so that  $d_{p_{kl}}(f') = L - \varepsilon$ . Then, the flow  $f'$  is an equilibrium flow of cost  $L - \varepsilon$  for the resulting network, which has one edge less than the original network  $H_1$ . If  $\sum_p r_p < 0$  and it first becomes  $\sum_p r_p = -f_{kl}$ , we remove the edge  $e_{kl}$  from  $H_1$ . Then,  $f'$  is an equilibrium flow of cost  $L - \varepsilon$  for the resulting network, which again has one edge less than  $H_1$ . If  $\sum_p r_p > 0$  and it first becomes  $d_{p_{kl}}(f') = L + b_{kl} - \varepsilon$ , we set the constant latency of the edge  $e_{kl}$  to  $b'_{kl} = 0$ . In this case,  $f'$  is an equilibrium flow of cost  $L - \varepsilon$  for the resulting network that has one edge of 0 latency more than the initial network  $H_1$ .

If  $\bar{F}$  is singular, proceeding similarly, we compute  $r_p$ 's so that  $f'$  is an equilibrium flow of cost  $L$  in a modified network that includes one edge less than the original network  $H_1$ . When  $\bar{F}$  is singular, the homogeneous linear system  $\bar{F}\bar{r} = \bar{0}$  admits a nontrivial solution  $\bar{r} \neq \bar{0}$ . Moreover, due to linearity, for any  $a \in \mathbb{R}$ ,  $a\bar{r}$  is also a solution to  $\bar{F}\bar{r} = \bar{0}$ . Therefore, the linear system  $\mathcal{Q}_0 = \{\bar{F}\bar{r} = \bar{0}, f_p - r_p \geq 0 \ \forall p \in \mathcal{P}, f_{kl} + \sum_p r_p \geq 0\}$  admits a solution  $\bar{r} \neq \bar{0}$  that makes at least one of the inequalities tight. We recall that the  $p$ -th component of  $\bar{F}\bar{r}$  is equal to  $d_p(f) - d_p(f')$ . Therefore, for the flow  $f'$  obtained from the particular solution  $\bar{r}$  of  $\mathcal{Q}_0$ , the latency of any path  $p \in \mathcal{P}$  is equal to  $L$ . If  $\bar{r}$  is such that  $r_p = f_p$  for some path  $p = (s, u_i, v_j, t) \in \mathcal{P}$ , we remove the edge  $\{u_i, v_j\}$  from  $H_1$  and adjust the constant latency of  $e_{kl}$  so that  $d_{p_{kl}}(f') = L$ . Then, the flow  $f'$  is an equilibrium flow of cost  $L$  for the resulting network, which has one edge less than the original network  $H_1$ . If  $\bar{r}$  is such that  $\sum_p r_p = -f_{kl}$ , we remove the edge  $e_{kl}$  from  $H_1$ . Then,  $f'$  is an equilibrium flow of cost  $L$  for the resulting network, which again has one edge less than  $H_1$ .

Each time we apply the procedure above either we decrease the number of edges of the intermediate network by one or we increase the number of 0-latency edges of the intermediate network by one, without increasing the latency of the equilibrium flow. Moreover, if  $p_{kl}$  is disjoint to the paths  $p \in \mathcal{P}$ ,  $\bar{F}$  is non-singular (next paragraph) and the procedure above leads to a decrease in the equilibrium latency, and eventually to setting  $b'_{kl} = 0$ . So by repeatedly applying these steps, we end up with a subnetwork  $H'$  of the 0-latency simplification of  $H$  with  $L(H', r) \leq L(H, r)$ .

To show that if  $p_{kl}$  is disjoint to the paths  $p \in \mathcal{P}$ ,  $\bar{F}$  is non-singular we show that the matrix  $\bar{F}$  is positive definite (which implies that  $\bar{F}$  is

non-singular). We first note that if  $p_{kl}$  is disjoint to all  $p \in \mathcal{P}$ , then for all  $p_1, p_2 \in \mathcal{P}$ ,  $\bar{F}[p_1, p_2] = \sum_{e \in p_1 \cap p_2} a_e$ . Hence, for all  $\bar{x} \in \mathbb{R}^{|\mathcal{P}|}$ ,  $\bar{x}^T \bar{F} \bar{x} = \sum_{e \in E(\mathcal{P})} a_e x_e^2 \geq 0$ , where  $E(\mathcal{P})$  denotes the set of edges included in the paths of  $\mathcal{P}$  and  $x_e = \sum_{p: e \in p} x_p$ . Since the intermediate network of  $H_1$  is acyclic and any flow in  $H_1$  has a unique path decomposition, if  $\bar{x}$  has one or more non-zero components, there is at least one edge  $e$  adjacent to either  $s$  or  $t$  such that  $x_e > 0$ , and thus  $\bar{x}^T \bar{F} \bar{x} > 0$ . Otherwise, the difference of the flow defined by  $\bar{x}$  with the trivial flow defined by  $\bar{0}$  would indicate the existence of a cycle in the intermediate subnetwork of  $H_1$ . This is a contradiction, since by the first part of the proof, the intermediate part of  $H_1$  is acyclic.  $\square$

## 5.4 Προσεγγίζοντας το Βέλτιστο Υποδίκτυο στα Απλοποιημένα Δίκτυα

We proceed to show how to approximate the BestSubEL problem in a balanced 0-latency simplified network  $G_0$  with reasonable latencies. We may always regard  $G_0$  as the 0-latency simplification of a good network  $G$ . We first prove two useful lemmas (lemmas 12.3 and 12.4) about the maximum traffic rate  $r$  up to which BestSubEL remains interesting, and about the maximum amount of flow routed on any edge / path in the best subnetwork.

**Lemma 5.3.** Let  $G_0$  be any 0-latency simplified network, let  $r > 0$ , and let  $H_0^*$  be the best subnetwork of  $(G_0, r)$ . For any  $\varepsilon > 0$ , if  $r > \frac{B_{\max} n_+}{A_{\min} \varepsilon}$ , then  $L(G_0, r) \leq (1 + \varepsilon)L(H_0^*, r)$ .

*Proof.* We first show that for 0-latency simplified instances  $(G_0, r)$ , we can assume, essentially wlog., that the traffic rate  $r = O(n_+/\varepsilon)$ . Otherwise, a Nash flow  $f$  of  $(G_0, r)$  is an  $(1 + \varepsilon)$ -approximation of the BestSubEL problem in  $(G_0, r)$ .

To go on with the proof, we assume that  $r > \frac{B_{\max} n_+}{A_{\min} \varepsilon}$ , let  $f$  be a Nash flow of  $(G_0, r)$ , and consider how  $f$  allocates  $r$  units of flow to the edges of  $E_s \equiv E_s(G_0)$  and to the edges  $E_t \equiv E_t(G_0)$ . For simplicity, we let  $L \equiv L(G_0, r)$  denote the equilibrium latency of  $G_0$ , and let  $A_s = \sum_{e \in E_s} 1/a_e$  and  $A_t = \sum_{e \in E_t} 1/a_e$ .

Since  $G_0$  is a 0-latency simplified network and  $f$  is a Nash flow of  $(G_0, r)$ , there are  $L_1, L_2 > 0$ , with  $L_1 + L_2 = L$ , such that all used edges incident to  $s$  (resp. to  $t$ ) have latency  $L_1$  (resp.  $L_2$ ) in the Nash flow  $f$ . Since  $r > \frac{B_{\max} n_+}{A_{\min}}$ ,  $L_1, L_2 > B_{\max}$  and all edges in  $E_s \cup E_t$  are used by  $f$ . Moreover,

by an averaging argument, we have that there is an edge  $e \in E_s$  with  $a_e f_e \leq r/A_s$ , and that there is an edge  $e \in E_t$  with  $a_e f_e \leq r/A_t$ . Therefore,  $L_1 \leq (r/A_s) + B_{\max}$  and  $L_2 \leq (r/A_t) + B_{\max}$ , and thus,  $L \leq \frac{r}{A_s} + \frac{r}{A_t} + 2B_{\max}$ .

On the other hand, if we ignore the additive terms  $b_e$  of the latency functions, the optimal average latency of the players is  $r/A_s + r/A_t$ , which implies that  $L(H_0^*, r) \geq r/A_s + r/A_t$ . Therefore,  $L \leq L(H_0^*, r) + 2B_{\max}$ . Moreover, since  $r > \frac{B_{\max} n_+}{A_{\min} \varepsilon}$ ,  $A_s \leq n_s/A_{\min}$ , and  $A_t \leq n_t/A_{\min}$ , we have that:

$$\begin{aligned} L(H_0^*, r) &\geq \frac{r}{A_s} + \frac{r}{A_t} \\ &\geq \frac{B_{\max} n_s}{A_{\min} \varepsilon} \frac{A_{\min}}{n_s} + \frac{B_{\max} n_t}{A_{\min} \varepsilon} \frac{A_{\min}}{n_t} \\ &\geq 2B_{\max}/\varepsilon \end{aligned}$$

Therefore,  $2B_{\max} \leq \varepsilon L(H_0^*, r)$ , and  $L \leq (1 + \varepsilon)L(H_0^*, r)$ . □

**Lemma 5.4.** Let  $G_0$  be a balanced 0-latency simplified network with reasonable latencies, let  $r > 0$ , and let  $f$  be a Nash flow of the best subnetwork of  $(G_0, r)$ . For any  $\varepsilon > 0$ , if  $\Pr[\mathcal{B} \leq \varepsilon/4] \geq \delta$ , for some constant  $\delta > 0$ , there exists a constant  $\rho = \frac{24A_{\max}B_{\max}}{\delta\varepsilon A_{\min}^2}$  such that with probability at least  $1 - e^{-\delta n_-/8}$ ,  $f_e \leq \rho$ , for all edges  $e$ .

*Proof.* We proceed to show that in a 0-latency simplified instance  $(G_0, r)$ , the best subnetwork Nash flow routes  $O(r/n_+)$  units of flow on any edge and on any  $s-t$  path with high probability (where the probability is with respect to the random choice of the latency function coefficients). Intuitively, we show that in the best subnetwork Nash flow, with high probability, all used edges and all used  $s-t$  paths route a volume of flow not significantly larger than their fair share. We first prove the following technical lemma:

**Lemma 5.5.** Let  $G_0$  be a balanced 0-latency simplified network with reasonable latencies, let  $r > 0$  be any traffic rate, and let  $f$  be any Nash flow of the best subnetwork of  $(G_0, r)$ . For any  $\varepsilon > 0$ , if  $L(G, r) \geq \varepsilon$  and  $\Pr[\mathcal{B} \leq \varepsilon/4] \geq \delta$ , for some constant  $\delta > 0$ , there exists a constant  $\gamma = \frac{24A_{\max}}{\delta A_{\min}}$  such that with probability at least  $1 - e^{-\delta n_-/8}$ , for all edges  $e$ ,  $f_e \leq \gamma r/n_+$ .

*Proof.* We let  $L \equiv L(G_0, r)$  denote the equilibrium latency and  $g$  denote a Nash flow of the original instance  $(G_0, r)$ . Since  $G_0$  is a 0-latency simplified network and  $g$  is a Nash flow of  $(G_0, r)$ , there are  $L_1, L_2 > 0$ , with  $L_1 + L_2 = L$ , such that: (i) for any edge  $e$  incident to  $s$ , if  $b_e < L_1$ ,  $g_e > 0$  and  $a_e g_e + b_e = L_1$ , while  $g_e = 0$ , otherwise, and (ii) for any edge  $e$  incident to  $t$ , if  $b_e < L_2$ ,  $g_e > 0$  and  $a_e g_e + b_e = L_2$ , while  $g_e = 0$ , otherwise. Namely, all used edges

incident to  $s$  (resp. to  $t$ ) have latency  $L_1$  (resp.  $L_2$ ) in the Nash flow  $g$ . Wlog., we assume that  $L_1 \geq L_2$ , and thus,  $L_1 \geq L/2 \geq \varepsilon/2$ .

We next show that (i) if  $L \geq \varepsilon$  and  $\Pr[\mathcal{B} \leq \varepsilon/4] \geq \delta$ , then with probability at least  $1 - e^{-\delta n_-/8}$ ,  $L \leq \frac{24A_{\max}r}{\delta n_+}$ , and (ii) that for any  $e$ ,  $f_e \leq L/A_{\min}$ . The lemma follows by combining (i) and (ii).

We start with the proof of (i). Let  $e$  be any edge incident to  $s$  with  $b_e \leq \varepsilon/4$ . By the discussion above, in the Nash flow  $g$  of  $(G_0, r)$ ,  $g_e > 0$  and  $a_e g_e + b_e = L_1$ . Using that  $L_1 \geq L/2 \geq \varepsilon/2$ , we obtain that:

$$L_1 = a_e g_e + b_e \leq a_e g_e + \varepsilon/4 \Rightarrow g_e \geq \frac{L_1 - \varepsilon/4}{a_e} \geq \frac{L_1}{2a_e} \geq \frac{L}{4A_{\max}} \quad (5.1)$$

Moreover, since  $\Pr[\mathcal{B} \leq \varepsilon/4] \geq \delta$ , we use Chernoff bounds (e.g., [48, (7)]), and obtain that:

$$\Pr[\{|e \in E_s(G_0) \text{ with } b_e \leq \varepsilon/4\}| \geq \delta n_s/2] \geq 1 - e^{-\delta n_s/8} \quad (5.2)$$

Combining (12.2) and (12.1), we obtain that if  $L \geq \varepsilon$  and  $\Pr[\mathcal{B} \leq \varepsilon/4] \geq \delta$ , with probability at least  $1 - e^{-\delta n_-/8}$ , the flow rate  $r$  is at least  $\frac{L\delta n_s}{8A_{\max}}$ , or equivalently, that:

$$L \leq \frac{8A_{\max}r}{\delta n_s} \leq \frac{24A_{\max}r}{\delta n_+} \quad (5.3)$$

The last inequality holds because  $G_0$  is balanced, and  $|n_s - n_t| \leq 2n_-$ . This concludes the proof of (i).

To prove (ii), we observe that in the best subnetwork equilibrium flow  $f$ , no used edge  $e$  has latency greater than  $L$ . Therefore, for any used edge  $e$  incident to either  $s$  or  $t$ , we have that:

$$a_e f_e + b_e \leq L \Rightarrow f_e \leq \frac{L}{a_e} \leq \frac{L}{A_{\min}} \quad (5.4)$$

Moreover, any edge  $e$  in the intermediate subnetwork of  $G$  has  $f_e \leq L/A_{\min}$  due to the flow conservation constraints. This concludes the proof of (ii).  $\square$

We recall that we always assume that  $L(G, r) \geq \varepsilon$ , since otherwise the problem of approximating BestSubEL is trivial. Moreover, by the definition of reasonable latency functions, we have that for any constant  $\varepsilon > 0$ , there is a constant  $\delta > 0$ , such that  $\Pr[\mathcal{B} \leq \varepsilon/4] \geq \delta$ . Combining these assumptions with Lemma 12.3 and Lemma 12.5, we obtain Lemma 12.4. So from now on, we can assume, with high probability and wlog., that the Nash flow in the best subnetwork of any simplified instance  $(G_0, r)$  routes  $O(1)$  units of flow on any used edge and on any used path.  $\square$

**Approximating the Best Subnetwork of Simplified Networks.** First we state an approximate version of Caratheodory's theorem, proved in [12], that is needed for proving the correctness and efficiency of our approximation scheme.

**Theorem 5.6** ([12], Theorem 3). Let  $X$  be a set of vectors  $X = \{x_1, \dots, x_n\} \subset \mathbb{R}^d$  and  $\varepsilon > 0$ . For every  $\mu \in \text{conv}(X)$  and  $2 \leq p \leq \infty$  there exist an  $O(\frac{p\gamma^2}{\varepsilon^2})$  uniform vector  $\mu' \in \text{conv}(X)$  such that  $\|\mu - \mu'\|_p \leq \varepsilon$ , where  $\gamma = \max_{x \in X} \|x\|_p$  and a  $k$  uniform vector is a vector that can be written as an average of  $k$  vectors of  $X$  with replacements allowed.

We proceed to derive an approximation scheme for the best subnetwork of any simplified instance  $(G_0, r)$ .

**Theorem 5.7.** Let  $G_0$  be a balanced 0-latency simplified network with reasonable latencies, let  $r > 0$ , and let  $H_0^*$  be the best subnetwork of  $(G_0, r)$ . Then, for any  $\varepsilon > 0$ , we can compute, in time  $n_+^{O(A_{\max}^2 r^2 / \varepsilon^2)}$ , a flow  $f$  and a subnetwork  $H_0$  consisting of the edges used by  $f$ , such that (i)  $f$  is an  $\varepsilon$ -Nash flow of  $(H_0, r)$ , (ii)  $L(f) \leq L(H_0^*, r) + \varepsilon/2$ , and (iii) there exists a constant  $\rho > 0$ , such that  $f_e \leq \rho + \varepsilon$ , for all  $e$ .

*Proof.* We will use theorem 12.6 to prove the existence of a flow with the properties (i), (ii) and (iii). Then by exhaustive search we will find one such.

For every path  $p_{ij} = (s, u_i, v_j, t)$  let  $x_{p_{ij}}$  be a vector indexed by the edges of  $E(G_0)$ , i.e.  $x_{p_{ij}} \in \mathbb{R}^{|E(G_0)|}$ , that contains everywhere 0, except from the slots that correspond to edges  $(s, u_i)$ ,  $(u_i, v_j)$  and  $(v_j, t)$  where it contains number  $r$ . Clearly, every feasible flow of  $G_0$  can be written as a convex combination of  $x_{p_{ij}}$ . Let  $k = n_+ \cdot n_-$  be the number of different paths in  $G_0$  and for ease of notation let  $X = \{x_1, \dots, x_k\}$  denote the set containing all  $x_{p_{ij}}$ 's, according to an arbitrary ordering.

Let  $\mu$  be the Nash flow of the best subnetwork  $H_0^*$ . Using theorem 12.6 with set  $X$  as defined above, the Nash flow  $\mu \in \text{conv}(X)$ , the  $\|\cdot\|_2$  norm, i.e.  $p=2$ , and with  $\gamma$  being  $\gamma = r\sqrt{3}$  we get that there is an  $O(\frac{A_{\max}^2 r^2}{\varepsilon^2})$  uniform vector  $f$  such that  $\|\mu - f\|_2 \leq \frac{\varepsilon}{4A_{\max}}$ , which directly implies  $|\mu_e - f_e| \leq \frac{\varepsilon}{4A_{\max}}$  and implies property (iii) for  $f$ , due to Lemma 12.4.

The cost of a path  $p_{ij} = (s, u_i, v_j, t)$  in  $H_0^*$  under  $f$  is  $d_{p_{ij}}(f) = a_i f_{(s,u_i)} + b_i + a_j f_{(v_j,t)} + b_j$ . Because of  $|\mu_e - f_e| \leq \frac{\varepsilon}{4A_{\max}}$  we have

$$a_i \mu_{(s,u_i)} + b_i - \frac{\varepsilon}{4} + a_j \mu_{(v_j,t)} + b_j - \frac{\varepsilon}{4} \leq d_{p_{ij}}(f) \leq a_i \mu_{(s,u_i)} + b_i + \frac{\varepsilon}{4} + a_j \mu_{(v_j,t)} + b_j + \frac{\varepsilon}{4},$$

which gives  $d_{p_{ij}}(\mu) - \frac{\varepsilon}{2} \leq d_{p_{ij}}(f) \leq d_{p_{ij}}(\mu) + \frac{\varepsilon}{2}$ . As  $\mu$  is the Nash flow of the best subnetwork  $H_0^*$  we get

$$L(H_0^*, r) - \frac{\varepsilon}{2} \leq d_p(f) \leq L(H_0^*, r) + \frac{\varepsilon}{2}, \quad (5.5)$$

for any path  $p$  in  $H_0^*$ .

Let  $H_0$  be the subnetwork induced by the paths used by  $f$ . By 12.5,  $f$  in  $H_0$  satisfies (i) and (ii) of the theorem.

One can find such an  $f$  in time  $k^{O(\frac{A_{\max}^2 r^2}{\varepsilon^2})}$  by exhaustively searching for this  $f$  in all possible  $O(\frac{A_{\max}^2 r^2}{\varepsilon^2})$  combinations of the  $k = n_+ \cdot n_-$  paths of  $G_0$ . By checking all possible  $O(\frac{A_{\max}^2 r^2}{\varepsilon^2})$  uniform vectors for each of these combinations and keeping, among all acceptable flows that satisfy (i) and (ii), the acceptable flow  $f$  that minimizes the maximum amount flow routed on any edge, we get  $f_e \leq \rho + \varepsilon$ , for all edges  $e$ , i.e. we get property (iii). The latter is because we know that any Nash flow  $g$  of  $(H_0^*, r)$  routes  $g_e \leq \rho$  units of flow on any edge  $e$  (Lemma 12.4), and that in the exhaustive search step, one of the acceptable flows  $f$  has  $|g_e - f_e| \leq \varepsilon$ , for all edges  $e$  which implies that there is an acceptable flow  $f$  with  $f_e \leq \rho + \varepsilon$ , for all edges  $e$ .  $\square$

## 5.5 Επεκτείνοντας τη Λύση στα Καλά Δίκτυα

Given a good instance  $(G, r)$ , we create the 0-latency simplification  $G_0$  of  $G$ , and using Theorem 12.7, we compute a subnetwork  $H_0$  and an  $\varepsilon/6$ -Nash flow  $f$  that comprise an approximate solution to BestSubEL for  $(G_0, r)$ . Next, we show how to extend  $f$  to an approximate solution to BestSubEL for the original instance  $(G, r)$ . The intuition is that the 0-latency edges of  $H_0$  used by  $f$  to route flow from  $V_s$  to  $V_t$  can be “simulated” by low-latency paths of  $G_m$ . We first formalize this intuition for the subnetwork of  $G$  induced by the neighbors of  $s$  with (almost) the same latency  $B_s$  and the neighbors of  $t$  with (almost) the same latency  $B_t$ , for some  $B_s, B_t$  with  $B_s + B_t \approx L(f)$ . We may think of the networks  $G$  and  $H_0$  in the lemma below as some small parts of the original network  $G$  and of the actual subnetwork  $H_0$  of  $G_0$ . Thus, we obtain the following lemma, which serves as a building block in the proof of Lemma 12.9.

**Lemma 5.8.** We assume that  $G(V, E)$  is a  $(n, p, 1)$ -good network, with a possible violation of the maximum degree bound by  $s$  and  $t$ , but with  $|V_s|, |V_t| \leq 3knp/2$ , for some constant  $k > 0$ . Also the latencies of the edges in  $E_s \cup E_t$  are not random, but there exist constants  $B_s, B_t \geq 0$ , such that for all  $e \in E_s$ ,  $d_e(x) = B_s$ , and for all  $e \in E_t$ ,  $d_e(x) = B_t$ . We let  $r > 0$  be any traffic rate, let  $H_0$  be any subnetwork of the 0-latency simplification  $G_0$  of  $G$ , and let  $f$  be any flow of  $(H_0, r)$ . We assume that there exists a constant  $\rho' > 0$ , such that for all  $e \in E(H_0)$ ,  $0 < f_e \leq \rho'$ . Then, for any  $\varepsilon_1 > 0$ , with high probability, wrt. the random choice of the latency



functions of  $G$ , we can compute in  $\text{poly}(|V|)$  time a subnetwork  $G'$  of  $G$ , with  $E_s(G') = E_s(H_0)$  and  $E_t(G') = E_t(H_0)$ , and a flow  $g$  of  $(G', r)$  such that (i)  $g_e = f_e$  for all  $e \in E_s(G') \cup E_t(G')$ , (ii)  $g$  is a  $7\epsilon_1$ -Nash flow in  $G'$ , and (iii)  $L_{G'}(g) \leq B_s + B_t + 7\epsilon_1$ .

*Proof.* For convenience and wlog., we assume that  $E_s(G) = E_s(H_0)$  and that  $E_t(G) = E_t(H_0)$ , so that we simply write  $V_s$ ,  $V_t$ ,  $E_s$ , and  $E_t$  from now on. For each  $e \in E_s \cup E_t$ , we let  $g_e = f_e$ . So, the flow  $g$  satisfies (i), by construction.

We compute the extension of  $g$  through  $G_m$  as an “almost” Nash flow in a modified version of  $G$ , where each edge  $e \in E_s \cup E_t$  has a capacity  $g_e = f_e$  and a constant latency  $d_e(x) = B_s$ , if  $e \in E_s$ , and  $d_e(x) = B_t$ , if  $e \in E_t$ . All other edges  $e$  of  $G$  have an infinite capacity and a (randomly chosen) reasonable latency function  $d_e(x)$ .

We let  $g$  be the flow of rate  $r$  that respects the capacities of the edges in  $E_s \cup E_t$ , and minimizes  $\text{Pot}(g) = \sum_{e \in E} \int_0^{g_e} d_e(x) dx$ . Such a flow  $g$  can be computed in strongly polynomial time (see e.g., [85]). The subnetwork  $G'$  of  $G$  is simply  $G_g$ , namely, the subnetwork that includes only the edges used by  $g$ . It could have been that  $g$  is not a Nash flow of  $(G, r)$ , due to the capacity constraints on the edges of  $E_s \cup E_t$ . However, since  $g$  is a minimizer  $\text{Pot}(g)$ , for any  $u \in V_s$  and  $v \in V_t$ , and any pair of  $s-t$  paths  $p, p'$  going through  $u$  and  $v$ , if  $g_p > 0$ , then  $d_p(g) \leq d_{p'}(g)$ .

We next adjust the proof of [24, Lemma 5], and show that for any  $s-t$  path  $p$  used by  $g$ ,  $d_p(g) \leq B_s + B_t + 7\epsilon_1$ . To prove this, we let  $p = (s, u, \dots, v, t)$  be the  $s-t$  path used by  $g$  that maximizes  $d_p(g)$ . We show the existence of a path  $p' = (s, u, \dots, v, t)$  in  $G$  of latency  $d_{p'}(g) \leq B_s + B_t + 7\epsilon_1$ . Therefore, since  $g$  is a minimizer of  $\text{Pot}(g)$ , the latency of the maximum latency  $g$ -used path  $p$ , and thus the latency of any other  $g$ -used  $s-t$  path, is at most  $B_s + B_t + 7\epsilon_1$ , i.e.,  $g$  satisfies (iii). Moreover, since for any  $s-t$  path  $p$ ,  $d_p(g) \geq B_s + B_t$ ,  $g$  is an  $7\epsilon_1$ -Nash flow in  $G'$ .

Let  $p = (s, u, \dots, v, t)$  be the  $s-t$  path used by  $g$  that maximizes  $d_p(g)$ . To show the existence of a path  $p' = (s, u, \dots, v, t)$  in  $G$  of latency  $d_{p'}(g) \leq B_s + B_t + 7\epsilon_1$ , we start from  $S_0 = \{u\}$  and grow a sequence of vertex sets  $S_0 \subseteq S_1 \subseteq \dots \subseteq S_{i^*}$ , stopping when  $|\Gamma(S_{i^*})| \geq 3n/5$  for the first time. We use the expansion properties of  $G$ , and condition (3), on the distribution of  $\mathcal{B}$ , in the definition of good networks, and show that these sets grow exponentially fast, and thus,  $i^* \leq \ln n$ , with high probability. Moreover, we show<sup>1</sup> that there are edges of latency  $\epsilon_1 + o(1)$  from  $S_0 = \{u\}$  to each vertex of  $S_1$ , and edges of latency  $\epsilon_1 / \ln n + o(1 / \ln n)$  from  $S_i$  to each vertex of  $S_{i+1}$ ,

<sup>1</sup>The intuition is that if among the edges  $e$  incident to  $V_s \cup V_t$ , we keep only those with  $b_e \leq \epsilon_1$ , and among all the remaining edges  $e$ , we keep only those with  $b_e \leq \epsilon_1 / \ln n$ , then due to condition (3) on the distribution of  $\mathcal{B}$ , a good network  $G$  remains an expander.

for all  $i = 1, \dots, i^* - 1$ . Thus, there is a path of latency at most  $2\epsilon_1 + o(1)$  from  $u$  to each vertex of  $S_{i^*}$ . Similarly, we start from  $T_0 = \{v\}$  and grow a sequence of vertex sets  $T_0 \subseteq T_1 \subseteq \dots \subseteq T_{j^*}$ , stopping when  $|\Gamma(T_{j^*})| \geq 3n/5$  for the first time. By exactly the same reasoning, we establish the existence of a path of latency at most  $2\epsilon_1 + o(1)$  from each vertex of  $T_{j^*}$  to  $v$ . Finally, since  $|\Gamma(S_{i^*})| \geq 3n/5$  and  $|\Gamma(T_{j^*})| \geq 3n/5$ , the neighborhoods of  $S_{i^*}$  and  $T_{j^*}$  contain at least  $n/10$  vertices in common. With high probability, most of these vertices can be reached from  $S_{i^*}$  and from  $T_{j^*}$  using edges of latency  $\epsilon_1 + o(1)$ . Putting everything together, we find a  $u - v$  path (in fact, many of them) of length  $O(\ln n)$  and latency at most  $6\epsilon_1 + o(1) \leq 7\epsilon_1$ .

For completeness, we next give a detailed proof, by adjusting the arguments in the proof of [24, Lemma 5]. For convenience, for each vertex  $x$ , we let  $d_s(x)$  (resp.  $d_t(x)$ ) be the latency wrt  $g$  of the shortest latency path from  $s$  to  $x$  (resp. from  $x$  to  $t$ ). Also, for any  $\delta > 0$ , we let  $P_b(\delta) \equiv \Pr[\mathcal{B} \leq \delta]$  denote the probability that the additive term of a reasonable latency is at most  $\delta$ . Recall also that by hypothesis, there exists a constant  $\rho' > 0$ , such that for all  $e \in E(H_0)$ ,  $f_e \leq \rho'$ . Hence, the total flow through  $G$  (and through  $H_0$ ) is  $r \leq \rho' n_+$ .

At the conceptual level, the proof proceeds as explained above. We start with  $S_0 = \{u\}$ . By hypothesis, the flow entering  $u$  is at most  $\rho'$ . By the expansion property of good networks and by Chernoff bounds<sup>2</sup>, with high probability, there are at least  $P_b(\epsilon_1)np/4$  edges  $e$  adjacent to  $u$  with  $b_e \leq \epsilon_1$ . At most half of these edges have flow greater than  $\frac{8\rho'}{P_b(\epsilon_1)np}$ , thus there are at least  $P_b(\epsilon_1)np/8$  edges adjacent to  $u$  with latency, wrt  $g$ , less than  $\frac{8A_{\max}\rho'}{P_b(\epsilon_1)np} + \epsilon_1$ . We now let  $d_1 = B_s + \frac{8A_{\max}\rho'}{P_b(\epsilon_1)np} + \epsilon_1$  and  $S_1 = \{x \in V : d_s(x) \leq d_1\}$ . By the discussion above,  $|S_1| \geq P_b(\epsilon_1)np/8$ .

We now inductively define a sequence of vertex sets  $S_i$  and upper bounds  $d_i$  on the latency of the vertices in  $S_i$  from  $s$ , such that  $S_i \subseteq S_{i+1}$  and  $d_i < d_{i+1}$ . This sequence stops the first time that  $|\Gamma(S_i)| \geq 3n/5$ . We inductively assume that the vertex set  $S_i$  and the upper bound  $d_i$  on the latency of the vertices in  $S_i$  are defined, and that  $|\Gamma(S_i)| < 3n/5$ . By the expansion property of good networks  $|\Gamma(S_i) \setminus S_i| \geq np|S_i|/3$ , for sufficiently large  $n$ . Thus, with probability at least  $1 - e^{-P_b(\epsilon_1/\ln n)np|S_i|/24}$ , there are at least  $P_b(\frac{\epsilon_1}{\ln n})np|S_i|/6$  vertices outside  $S_i$  that are connected to a vertex in  $S_i$  by an edge  $e$  with  $b_e \leq \epsilon_1/\ln n$ . Let  $S'_i$  be the set of such vertices, and let  $E_i$  be the set of edges that for each vertex  $v \in S'_i$ , includes a unique edge  $e \in E_i$  with  $b_e \leq \epsilon_1/\ln n$  connecting  $v$  to a vertex in  $S_i$ . Since the flow  $g$  may

<sup>2</sup>We repeatedly use the following form of the Chernoff bound (see e.g., [48]): Let  $X_1, \dots, X_k$  be random variables independently distributed in  $\{0, 1\}$ , and let  $X = \sum_{i=1}^k X_i$ . Then, for all  $\epsilon \in (0, 1)$ ,  $\Pr[X < (1 - \epsilon)\mathbf{E}[X]] \leq e^{-\epsilon^2 \mathbf{E}[X]/2}$ , where  $e$  is the basis of natural logarithms.

be assumed to be acyclic, a volume  $r \leq \rho' n_+$  of flow is routed through the cut  $(S_i, V \setminus S_i)$ . Then, at most half of the edges in  $E_i$  have flow greater than  $2\rho' n_+ / |S_i|$ . Consequently, at least half of the vertices  $v \in S_i$  have latency from  $s$ :

$$\begin{aligned} d_s(x) &\leq d_i + \frac{\epsilon_1}{\ln n} + A_{\max} \frac{2\rho' n_+}{|S_i|} \\ &\leq d_i + \frac{\epsilon_1}{\ln n} + \frac{12A_{\max}\rho' n_+}{P_b(\frac{\epsilon_1}{\ln n})np|S_i|} \end{aligned}$$

Thus, we define the next latency upper bound  $d_{i+1}$  in the sequence as:

$$d_{i+1} = d_i + \frac{\epsilon_1}{\ln n} + \frac{12A_{\max}\rho' n_+}{P_b(\frac{\epsilon_1}{\ln n})np|S_i|},$$

and we let  $S_{i+1} = \{x \in V(G) | d_s(x) \leq d_{i+1}\}$ . By the discussion above, and using the inductive definition of  $S_i$ 's, we obtain that:

$$\begin{aligned} |S_{i+1}| &\geq \left(\frac{1}{12}P_b(\epsilon_1/\ln n)np + 1\right)|S_i| \\ &\geq \left(\frac{1}{12}P_b(\epsilon_1/\ln n)np + 1\right)^i |S_1| \end{aligned}$$

We recall that  $i^*$  is the first index  $i$  such that  $|\Gamma(S_i)| \geq 3n/5$ . Then, the inequality above implies that:

$$i^* \leq \frac{\ln(3n/(5|S_1|))}{\ln\left(\frac{1}{12}P_b(\epsilon_1/\ln n)np + 1\right)} \leq \frac{\ln(24n/(5P_b(\epsilon_1)np))}{\ln\left(\frac{1}{12}P_b(\epsilon_1/\ln n)np + 1\right)}$$

Using that  $pn \geq \ln n$  and that  $P_b(\epsilon_1/\ln n)np = \omega(1)$ , the inequality above implies that  $i^* \leq \ln n$ , for sufficiently large  $n$ .

Therefore, we obtain an upper bound on the latency from  $s$  of any vertex in  $S_{i^*}$ :

$$\begin{aligned} d_{i^*} &\leq d_0 + i^* \frac{\epsilon_1}{\ln n} + \sum_{i=1}^{i^*} \frac{12A_{\max}\rho' n_+}{P_b(\frac{\epsilon_1}{\ln n})np|S_i|} \\ &\leq d_1 + \frac{\epsilon_1}{\ln n} \ln n + \sum_{i=1}^{\ln n} \frac{12A_{\max}\rho' n_+}{P_b(\frac{\epsilon_1}{\ln n})np \left(\frac{1}{12}P_b(\frac{\epsilon_1}{\ln n})np + 1\right)^i |S_1|} \\ &= d_1 + \epsilon_1 + \frac{12A_{\max}\rho' n_+}{P_b(\frac{\epsilon_1}{\ln n})np|S_1|} \sum_{i=1}^{\ln n} \left(\frac{1}{12}P_b(\frac{\epsilon_1}{\ln n})np + 1\right)^{-i} \\ &\leq \left(B_s + \frac{8A_{\max}\rho'}{P_b(\epsilon_1)np} + \epsilon_1\right) + \epsilon_1 + \frac{96A_{\max}\rho' n_+}{P_b(\frac{\epsilon_1}{\ln n})P_b(\epsilon_1)(np)^2} \sum_{i=1}^{\infty} 2^{-i} \\ &\leq B_s + 2\epsilon_1 + \frac{8A_{\max}\rho'}{P_b(\epsilon_1)np} + \frac{144A_{\max}\rho' k}{P_b(\frac{\epsilon_1}{\ln n})P_b(\epsilon_1)np} \end{aligned}$$

For the penultimate inequality, we use that  $P_b(\epsilon_1/\ln n)np = \omega(1)$ , which implies that  $1 + P_b(\epsilon_1/\ln n)np/12 \geq 2$ , for  $n$  sufficiently large. For the last inequality, we use that  $n_+ \leq 3knp/2$ , for some constant  $k > 0$ , by hypothesis.

Moreover, we observe that probability that the above construction fails is at most:

$$\begin{aligned} \sum_{i=1}^{i^*} e^{-P_b(\epsilon_1/\ln n)np|S_i|/24} &\leq \sum_{i=1}^{i^*} e^{-\left(\frac{1}{12}P_b(\epsilon_1/\ln n)np+1\right)^i|S_i|/24} \\ &\leq \ln n e^{-\left(\frac{1}{12}P_b(\epsilon_1/\ln n)np+1\right)P_b(\epsilon_1)np/192} \end{aligned}$$

Therefore, the construction above succeeds with high probability.

Similarly, we start from  $T_0 = \{v\}$ , and inductively define a sequence of vertex sets  $T_0 \subseteq T_1 \subseteq \dots \subseteq T_{j^*}$ , and a sequence of upper bounds  $d'_0 < d'_1 < \dots < d'_{j^*}$  on the latency from  $t$  of the vertices in each  $T_j$ . We let  $T_j = \{x \in V(G) | d_t(x) \leq d'_j\}$ . The sequence stops as soon as  $|\Gamma(T_j)| \geq 3n/5$  for the first time. Namely,  $j^*$  is the first index with  $|\Gamma(T_{j^*})| \geq 3n/5$ . Using exactly the same arguments, we can show that with high probability, we have that  $j^* \leq \ln n$ , and that:

$$d'_{j^*} \leq B_t + 2\epsilon_1 + \frac{8A_{\max}\rho'}{P_b(\epsilon_1)np} + \frac{144A_{\max}\rho'k}{P_b(\frac{\epsilon_1}{\ln n})P_b(\epsilon_1)np}$$

Wlog., we assume that  $S_{i^*} \cap T_{j^*} = \emptyset$ . Since  $|\Gamma(S_{i^*})| + |\Gamma(T_{j^*})| \geq 6n/5$ , there are at least  $n/10$  edge disjoint paths of length at most 2 between  $S_{i^*}$  and  $T_{j^*}$ . Furthermore, by Chernoff bounds, with high probability, there are at least  $P_b(\epsilon_1)^2 n/12$  such paths with both edges  $e$  on the path having  $b_e \leq \epsilon_1$ . At most half of these paths have flow more than  $2\frac{12\rho'n_+}{P_b(\epsilon_1)^2 n}$  and thus there is a path from a vertex of  $S_{i^*}$  to a vertex of  $T_{j^*}$  that costs at most  $2\epsilon_1 + 2A_{\max}\frac{24\rho'n_+}{P_b(\epsilon_1)^2 n}$ .

Putting everything together, we have that there is a path  $p'$  that starts from  $s$ , moves to  $u$ , goes through vertices of the sequence  $S_1, \dots, S_{i^*}$ , proceeds to a vertex of  $\Gamma(S_{i^*}) \cap \Gamma(T_{j^*})$ , and from there, continues through vertices of the sequence  $T_{j^*}, \dots, T_1$ , until finally reaches  $v$ , and then  $t$ . The latency of this path is:

$$d_{p'}(g) \leq B_s + B_t + 6\epsilon_1 + 2\left(\frac{8A_{\max}\rho'}{P_b(\epsilon_1)np} + \frac{48A_{\max}\rho'k}{P_b(\frac{\epsilon_1}{\ln n})P_b(\epsilon_1)np}\right) + \frac{48A_{\max}\rho'n_+}{P_b(\epsilon_1)^2 n}$$

We recall that since the flow  $g$  is a the minimizer of  $\text{Pot}(g)$ , for any  $g$ -used path  $p = (s, u, \dots, v, t)$ ,  $d_p(g) \leq d_{p'}(g)$ . Thus we obtain that any

$g$ -used path  $p = (s, u, \dots, v, t)$  has latency

$$d_p(g) \leq B_s + B_t + 6\epsilon_1 + 2\left(\frac{8A_{\max}\rho'}{P_b(\epsilon_1)np} + \frac{48A_{\max}\rho'k}{P_b(\frac{\epsilon_1}{\ln n})P_b(\epsilon_1)np}\right) + \frac{48A_{\max}\rho'n_+}{P_b(\epsilon_1)^2n}$$

Using the hypothesis that  $n_+ \leq 3knp/2$ , for constant  $k > 0$ , and that  $P_b(\epsilon_1/\ln n)np = \omega(1)$ , which is condition (3), in the definition of good networks, we obtain that for any constant  $\epsilon_1 > 0$ ,  $d_p(g) \leq B_s + B_t + 7\epsilon_1$ , for sufficiently large  $n$ .  $\square$

**Grouping the Neighbors of  $s$  and  $t$ .** Let us now consider the entire network  $G$  and the entire subnetwork  $H_0$  of  $G_0$ . Lemma 12.8 can be applied only to subsets of edges in  $E_s(H_0)$  and in  $E_t(H_0)$  that have (almost) the same latency under  $f$ . Hence, we partition the neighbors of  $s$  and the neighbors of  $t$  into classes  $V_s^i$  and  $V_t^j$  according to their latency. For convenience, we let  $\epsilon_2 = \epsilon/6$ , i.e.,  $f$  is an  $\epsilon_2$ -Nash flow, and  $L \equiv L_{H_0}(f)$ . By Theorem 12.7, applied with error  $\epsilon_2 = \epsilon/6$ , there exists a  $\rho$  such that for all  $e \in E(H_0)$ ,  $0 < f_e \leq \rho + \epsilon_2$ . Hence,  $L \leq 2A_{\max}(\rho + \epsilon_2) + 2B_{\max}$  is bounded by a constant.

We partition the interval  $[0, L]$  into  $\kappa = \lceil L/\epsilon_2 \rceil$  subintervals, where the  $i$ -th subinterval is  $I^i = (i\epsilon_2, (i+1)\epsilon_2]$ ,  $i = 0, \dots, \kappa - 1$ . We partition the vertices of  $V_s$  (resp. of  $V_t$ ) that receive positive flow by  $f$  into  $\kappa$  classes  $V_s^i$  (resp.  $V_t^i$ ),  $i = 0, \dots, \kappa - 1$ . Precisely, a vertex  $x \in V_s$  (resp.  $x \in V_t$ ), connected to  $s$  (resp. to  $t$ ) by the edge  $e_x = \{s, x\}$  (resp.  $e_x = \{x, t\}$ ), is in the class  $V_s^i$  (resp. in the class  $V_t^i$ ), if  $d_{e_x}(f_{e_x}) \in I_i$ . If a vertex  $x \in V_s$  (resp.  $x \in V_t$ ) does not receive any flow from  $f$ ,  $x$  is removed from  $G$  and does not belong to any class. Hence, from now on, we assume that all neighbors of  $s$  and  $t$  receive positive flow from  $f$ , and that  $V_s^0, \dots, V_s^{\kappa-1}$  (resp.  $V_t^0, \dots, V_t^{\kappa-1}$ ) is a partitioning of  $V_s$  (resp.  $V_t$ ). In exactly the same way, we partition the edges of  $E_s$  (resp. of  $E_t$ ) used by  $f$  into  $\kappa$  classes  $E_s^i$  (resp.  $E_t^i$ ),  $i = 0, \dots, \kappa - 1$ .

To find out which parts of the subnetwork  $H_0$  will be connected through the intermediate subnetwork of  $G$ , using the construction of Lemma 12.8, we further classify the vertices of  $V_s^i$  and  $V_t^j$  based on the neighbors of  $t$  and on the neighbors of  $s$ , respectively, to which they are connected by  $f$ -used edges in the subnetwork  $H_0$ . In particular, a vertex  $u \in V_s^i$  belongs to the classes  $V_s^{(i,j)}$ , for all  $j \in \{0, \dots, \kappa - 1\}$  such that there is a vertex  $v \in V_t^j$  with  $f_{\{u,v\}} > 0$ . Similarly, a vertex  $v \in V_t^j$  belongs to the classes  $V_t^{(i,j)}$ , for all  $i \in \{0, \dots, \kappa - 1\}$  such that there is a vertex  $u \in V_s^i$  with  $f_{\{u,v\}} > 0$ . We note that a vertex  $u \in V_s^i$  (resp.  $v \in V_t^j$ ) may belong to many different classes  $V_s^{(i,j)}$  (resp. to  $V_t^{(i,j)}$ ), and that the class  $V_s^{(i,j)}$  is non-empty iff the class  $V_t^{(i,j)}$  is non-empty, i.e., non-empty classes  $V_s^{(i,j)}$  and  $V_t^{(i,j)}$  appear in pairs. We let  $k \leq \kappa^2$  be the number of pairs  $(i, j)$  for which  $V_s^{(i,j)}$  and  $V_t^{(i,j)}$  are non-empty. We note that  $k$  is a constant, i.e., does not depend on  $|V|$  and  $r$ . We let  $E_s^{(i,j)}$

be the set of edges connecting  $s$  to the vertices in  $V_s^{(i,j)}$  and  $E_t^{(i,j)}$  be the set of edges connecting  $t$  to the vertices in  $V_t^{(i,j)}$ .

**Building the Intermediate Subnetworks of  $G$ .** The last step is to replace the 0-latency simplified parts connecting the vertices of each pair of classes  $V_s^{(i,j)}$  and  $V_t^{(i,j)}$  in  $H_0$  with a subnetwork of  $G_m$ . To this end, we randomly partition the set  $V_m$  of intermediate vertices of  $G$  into  $k$  subsets, each of cardinality (roughly)  $|V_m|/k$ , and associate a different such subset  $V_m^{(i,j)}$  with any pair of non-empty classes  $V_s^{(i,j)}$  and  $V_t^{(i,j)}$ . For each pair  $(i,j)$  for which the classes  $V_s^{(i,j)}$  and  $V_t^{(i,j)}$  are non-empty, we consider the induced subnetwork  $G^{(i,j)} \equiv G[\{s, t\} \cup V_s^{(i,j)} \cup V_m^{(i,j)} \cup V_t^{(i,j)}]$ , which is a  $(n/k, p, 1)$ -good network, by condition (4) in the definition of good networks, and because  $G$  is a  $(n, p, k)$ -good network. Therefore, we can apply Lemma 12.8 to  $G^{(i,j)}$ , with  $H_0^{(i,j)} \equiv H_0[\{s, t\} \cup V_s^{(i,j)} \cup V_t^{(i,j)}]$  in the role of  $H_0$ , the restriction  $f^{(i,j)}$  of  $f$  to  $H_0^{(i,j)}$  in the role of the flow  $f$ , and  $\rho' = \rho + \epsilon_2$ . Moreover, we let  $B_s^{(i,j)} = \max_{e \in E_s^{(i,j)}} d_e(f_e)$  and  $B_t^{(i,j)} = \max_{e \in E_t^{(i,j)}} d_e(f_e)$  correspond to  $B_s$  and  $B_t$ , and introduce constant latencies  $d'_e(x) = B_s^{(i,j)}$  for all  $e \in E_s^{(i,j)}$  and  $d'_e(x) = B_t^{(i,j)}$  for all  $e \in E_t^{(i,j)}$ , as required by Lemma 12.8. Thus, we obtain, with high probability, a subnetwork  $H^{(i,j)}$  of  $G^{(i,j)}$  and a flow  $g^{(i,j)}$  that routes as much flow as  $f^{(i,j)}$  on all edges of  $E_s^{(i,j)} \cup E_t^{(i,j)}$ , and satisfies the conclusion of Lemma 12.8, if we keep in  $H^{(i,j)}$  the constant latencies  $d'_e(x)$  for all  $e \in E_s^{(i,j)} \cup E_t^{(i,j)}$ .

The final outcome is the union of the subnetworks  $H^{(i,j)}$ , denoted  $H$  ( $H$  has the latency functions of the original instance  $G$ ), and the union of the flows  $g^{(i,j)}$ , denoted  $g$ , where the union is taken over all  $k$  pairs  $(i,j)$  for which the classes  $V_s^{(i,j)}$  and  $V_t^{(i,j)}$  are non-empty. By construction, all edges of  $H$  are used by  $g$ . We obtain lemma 12.9 by showing that if  $\epsilon_1 = \epsilon/42$  and  $\epsilon_2 = \epsilon/6$ , the flow  $g$  is an  $\epsilon$ -Nash flow of  $(H, r)$ , and satisfies  $L_H(g) \leq L_{H_0}(f) + \epsilon/2$ .

**Lemma 5.9.** Let any  $\epsilon > 0$ , let  $k = \lceil 12(A_{\max}(\rho + \epsilon) + B_{\max})/\epsilon \rceil^2$ , let  $G(V, E)$  be an  $(n, p, k)$ -good network, let  $r > 0$ , let  $H_0$  be any subnetwork of the 0-latency simplification of  $G$ , and let  $f$  be an  $(\epsilon/6)$ -Nash flow of  $(H_0, r)$  for which there exists a constant  $\rho' > 0$ , such that for all  $e \in E(H_0)$ ,  $0 < f_e \leq \rho'$ . Then, with high probability, wrt. the random choice of the latency functions of  $G$ , we can compute in  $\text{poly}(|V|)$  time a subnetwork  $H$  of  $G$  and an  $\epsilon$ -Nash flow  $g$  of  $(H, r)$  with  $L_H(g) \leq L_{H_0}(f) + \epsilon/2$ .

*Proof.* We consider the subnetwork  $H$  (with the original latency functions of  $G$ ), computed as the union of subnetworks  $H^{(i,j)}$ , and the flow  $g$ , computed as the union of the flows  $g^{(i,j)}$ , where the union is taken over all  $k$  pairs  $(i,j)$  for which the classes  $V_s^{(i,j)}$  and  $V_t^{(i,j)}$  are non-empty. We recall that by

construction, all edges of  $H$  are used by  $g$ . We show that if  $\epsilon_1 = \epsilon/42$  and  $\epsilon_2 = \epsilon/6$ , the flow  $g$  is an  $\epsilon$ -Nash flow of  $(H, r)$ , and satisfies  $L_H(g) \leq L_{H_0}(f) + \epsilon/2$ . We stress that the edge and path latencies here are calculated with respect to the original latency functions of  $G$  and under the edge congestion induced by the flow  $g$  (or the flow  $f$ ).

For convenience, we let  $B^{(i,j)} = B_s^{(i,j)} + B_t^{(i,j)}$  for any pair of non-empty classes  $V_s^{(i,j)}$  and  $V_t^{(i,j)}$ . Since the difference in the latency of any edges in the same group is at most  $\epsilon_2$ , we obtain that for any edge  $e \in E_s^{(i,j)}$ ,  $B_s^{(i,j)} - \epsilon_2 \leq d_e(f_e) \leq B_s^{(i,j)}$ , and similarly, that for any edge  $e \in E_t^{(i,j)}$ ,  $B_t^{(i,j)} - \epsilon_2 \leq d_e(f_e) \leq B_t^{(i,j)}$ . Therefore, since  $H_0$  is a 0-latency simplified network, and since by hypothesis, all the edges of  $H_0$  are used by  $f$ , for any pair of non-empty classes  $V_s^{(i,j)}$  and  $V_t^{(i,j)}$ , and for any  $s-t$  path  $p$  going through a vertex of  $V_s^{(i,j)}$  and a vertex of  $V_t^{(i,j)}$ ,

$$B^{(i,j)} - 2\epsilon_2 \leq d_p(f) \leq B^{(i,j)}$$

Moreover, since  $f$  is an  $\epsilon_2$ -Nash flow of  $(H_0, r)$ , for any  $s-t$  path  $p \in \mathcal{P}_{H_0}$ ,

$$L_{H_0}(f) - \epsilon_2 \leq d_p(f) \leq L_{H_0}(f)$$

Combining the two inequalities above, we obtain that for any pair of non-empty classes  $V_s^{(i,j)}$  and  $V_t^{(i,j)}$ ,

$$B^{(i,j)} - 2\epsilon_2 \leq L_{H_0}(f) \leq B^{(i,j)} + \epsilon_2 \quad (5.6)$$

As for the flow  $g$ , by construction, we have that  $g_e = f_e$  for all edges  $e \in E_s \cup E_t$ . Therefore, for any edge  $e \in E_s^{(i,j)}$ ,  $B_s^{(i,j)} - \epsilon_2 \leq d_e(g_e) \leq B_s^{(i,j)}$ , and similarly, for any edge  $e \in E_t^{(i,j)}$ ,  $B_t^{(i,j)} - \epsilon_2 \leq d_e(g_e) \leq B_t^{(i,j)}$ . Thus, by Lemma 12.8, and since all the edges of any subnetwork  $H^{(i,j)}$  are used by  $g$ , for any  $s-t$  path  $p$  in the subnetwork  $H^{(i,j)}$ ,  $B^{(i,j)} - 2\epsilon_2 \leq d_p(g) \leq B^{(i,j)} + 7\epsilon_1$ . Using that (12.6), we obtain that for any subnetwork  $H^{(i,j)}$  and any  $s-t$  path  $p$  of  $H^{(i,j)}$ ,

$$L_{H_0}(f) - 3\epsilon_2 \leq d_p(g) \leq L_{H_0}(f) + 2\epsilon_2 + 7\epsilon_1 \quad (5.7)$$

Furthermore, we recall that the subnetworks  $H^{(i,j)}$  only have in common the vertices  $s$  and  $t$ , and possibly some vertices of  $V_s \cup V_t$  and some edges of  $E_s \cup E_t$ . They have neither any other vertices in common, nor any edges connecting vertices in the intermediate parts of different subnetworks  $H^{(i,j)}$  and  $H^{(i',j')}$ . Hence, any  $s-t$  path  $p$  of  $H$  passes through a single subnetwork  $H^{(i,j)}$ . Therefore, and since by construction, all the edges and the paths of  $H$  are used by  $g$ , (12.7) holds for any  $s-t$  path  $p$  of  $H$ .

Thus, we have shown that  $g$  is a  $(5\epsilon_2 + 7\epsilon_1)$ -Nash flow of  $(H, r)$ , and that  $L_H(g) \leq L_{H_0}(f) + 2\epsilon_2 + 7\epsilon_1$ . Using  $\epsilon_2 = \epsilon/6$  and  $\epsilon_1 = \epsilon/42$ , we obtain the performance guarantees of  $g$  as stated in Lemma 12.9.  $\square$





## Κεφάλαιο 6

# Παίγνια Συμφόρησης με Παίκτες Ευαίσθητους στο Ρίσκο

Τα παίγνια συμφόρησης αγνοούν τη στοχαστική φύση στις καθυστερήσεις και την συμπεριφορά των χρηστών απέναντι στο φόβο. Για να λάβουμε αυτές τις επεκτάσεις υπόψιν, εισάγουμε δύο εκδοχές ατομικών παίγνιων, μια με στοχαστικούς παίκτες όπου κάθε παίκτης εναποθέτει το κομμάτι της ροής του στο δίκτυο με κάποια πιθανότητα, ανεξάρτητη των υπολοίπων παικτών, και μια με στοχαστικές ακμές όπου οι συναρτήσεις καθυστέρησης είναι τυχαίες. Και στις δύο εκδοχές οι παίκτες είναι ευαίσθητοι στο ρίσκο, και το εξειδικευμένο κόστος που υπολογίζει ο καθένας τους είναι ένα ποσοστό της κατανομής της καθυστέρησης του μονοπατιού του. Εστιάζουμε σε δίκτυα παράλληλων ακμών και εξετάζουμε κατά πόσο οι βασικές ιδιότητες των στοχαστικών παιγνίων συμφόρησης εξαρτώνται από την συμπεριφορά των παικτών απέναντι στο ρίσκο και τις πιθανότητες συμμετοχής των παικτών. Στη Βάση, αποδεικνύουμε ότι τα παίγνια σε δίκτυα παράλληλων ακμών έχουν πάντα μια αποδοτικά υπολογίσιμη ισορροπία αν οι παίκτες έχουν ίδιες πιθανότητες συμμετοχής ή ίδιο φόβο απέναντι στο ρίσκο ενώ έχουν και συνάρτηση δυναμικού αν οι παίκτες έχουν την ίδια συμπεριφορά απέναντι στο ρίσκο. Στην αρνητική πλευρά, παρουσιάζουμε στοχαστικά παίγνια συμφόρησης με παίκτες διαφορετικών αντιμετωπίσεων στο φόβο που δεν έχουν συνάρτηση δυναμικού. Όσο για την υπολειτουργία λόγω εγωιστικής συμπεριφοράς, για παράλληλα δίκτυα και γραμμικές συναρτήσεις αποδεικνύουμε ότι το τίμημα της αναρχίας είναι  $\Theta(n)$ , όπου  $n$  είναι ο αριθμός των στοχαστικών παικτών, και μπορεί να είναι μη φραγμένο, στην περίπτωση στοχαστικών ακμών.

## 6.1 Εισάγοντας τα Μοντέλα

In this chapter we generalize atomic congestion games. Recall that a (standard) atomic CG is the tuple  $\mathcal{G}(N, E, (S_i)_{i \in N}, (d_e)_{e \in E})$ . On the corresponding sections we will get more specific on the generalization we do, by explicitly defining the generalizing models.

In the technical part, we restrict our attention to symmetric congestion games on parallel-link networks, where strategies are singletons and there is a strategy for every resource. Since we mostly consider networks, we use the terms “resource” and “edge” and “strategy” and “path” interchangeably.

## 6.2 Παίγνια Συμφοράσης με Στοχαστικούς Παίκτες

### 6.2.1 Το μοντέλο

In Congestion Games with Stochastic Players, each player  $i$  is described by a tuple  $(p_i, \delta_i)$ , where  $p_i \in [0, 1]$  is the probability that player  $i$  participates in the game, by assigning a unit of load to her strategy, and  $\delta_i \in [\frac{1}{2}, 1]$  is the *confidence level* (or risk-aversion) of player  $i$ . Essentially, each player  $i$  is associated with a Bernoulli random variable  $X_i$  that is 1 with probability  $p_i$ , and 0 with probability  $1 - p_i$ . Then, the load of each edge  $e$  in a configuration  $s$  is the random variable  $N_e(s) = \sum_{i: e \in s_i} X_i$ , and the cost of a strategy  $q$  in  $s$  is the random variable  $D_q(s) = \sum_{e \in q} d_e(N_e(s))$ .

Given that player  $i$  participates in the game, the delay of player  $i$  in  $s$  is given by the random variable:

$$D_i(s) = \sum_{e \in s_i} d_e \left( 1 + \sum_{j \neq i: e \in s_j} X_j \right).$$

Note that when  $X_i = 1$ ,  $D_i(s) = D_{s_i}(s)$ .

The (risk-averse) individual cost  $c_i(s)$  perceived by player  $i$  in  $s$  is the  $\delta_i$ -quantile (or value-at-risk) of  $D_i(s)$ . Formally,  $c_i(s) = \min\{t : \Pr[D_i(s) \leq t] \geq \delta_i\}$ . We note that for parallel-link networks, the (risk-averse) individual cost of the players can be computed efficiently. PNE are defined as before, but with respect to the risk-averse individual cost of the players.

Depending on whether players have the same participation probabilities  $p_i$  and/or the same confidence levels  $\delta_i$ , we distinguish between four classes of congestion games with stochastic players:

- *homogeneous*, where all players have the same participation probability  $p$  and confidence level  $\delta$ .

- *p-homogeneous*, where all players have the same participation probability  $p$ , but may have different confidence levels.
- *$\delta$ -homogeneous*, where all players have the same confidence level  $\delta$ , but may have different participation probabilities.
- *heterogeneous*, where both the participation probabilities and the confidence levels may be different.

## 6.2.2 Στοχαστικοί παίκτες σε δίκτυα παραλλήλων ακμών: Ύπαρξη και υπολογισμός PNE

In the following, we restrict ourselves to Congestion Games with Stochastic Players on parallel-link networks, and investigate the existence and the efficient computation of PNE for the four cases considered above.

**Homogeneous Stochastic Players.** If the players are homogeneous, stochastic congestion games on parallel-links are equivalent to standard congestion games on parallel-links (but with possibly different latencies), because the (risk-averse) individual cost of each player in a configuration  $s$  depends only on the link  $e$  and its congestion  $s_e$ .

**Theorem 6.1.** Congestion Games with Homogeneous Stochastic Players on parallel-link networks admit an exact potential function. Moreover, a pure Nash equilibrium can be computed in polynomial time.

*Proof.* The existence of a potential function implies the existence of equilibrium. Rosenthal's potential function ([73]) suits this case as players, under any configuration, perceive exactly the same cost on any edge  $e$ , a cost that depends only on the number of players on  $e$ .

Formally, let  $p$  and  $\delta$  denote the common  $p_i$ 's and  $\delta_i$ 's of the players, and for each edge  $e$ , define a function  $f_e : \mathbb{N} \rightarrow \mathbb{R}$  with

$$f_e(r) = \begin{cases} 0, & \text{if } r = 0 \\ \min \left\{ t : \Pr \left[ d_e (1 + \sum_{i=1}^{r-1} Y_i) \leq t \right] \geq \delta \right\}, & \text{if } r > 0. \end{cases}$$

where for all  $i \in [r]$ ,  $Y_i$  is a Bernoulli random variable (independent of others) with probability of success  $p$ . Observe that for any configuration  $s$  and any player  $i$  with  $s_i = e$ , we have  $c_i(s) = f_e(s_e)$ .

Defining

$$\Phi(s) = \sum_e \sum_{i=1}^{s_e} f_e(i),$$

it is easy to verify that it is an exact potential function as for any player  $i$  and any two configurations  $s, s'$  such that  $s_{-i} = s'_{-i}$ ,  $s_i = e$  and  $s'_i = e'$

$$\Phi(s) - \Phi(s') = f_e(s_e) - f_{e'}(s_{e'} + 1) = c_i(s) - c_i(s').$$

In order to polynomially compute a PNE, we can simply use a *Greedy Best Response* algorithm. We insert the players in the game, one by one, and the player just inserted does a best response move. Each such move can be computed in time  $O(m + i^2)$ , where  $i$  is the number of players in the game so far, as for each edge  $e$ , the cumulative distribution function of  $D_e(s)$  can be computed via dynamic programming. One can easily verify, by induction, that on any round of this procedure, the players are in a PNE. Consequently, we get a PNE when the procedure terminates. Using memoization to avoid recalculations, the total time needed is  $O(n \cdot m + n^2)$ .  $\square$

**p-Homogeneous Stochastic Players.** In this case, a stochastic game is equivalent to a congestion game on parallel links with player-specific payoffs [63], as the (risk-averse) individual cost of each player in a configuration  $s$  depends only on the link  $e$ , its congestion  $s_e$ , and  $i$ 's confidence level  $\delta_i$ . Thus, we obtain:

**Corollary 6.2.** Congestion Games with  $p$ -Homogeneous Stochastic Players on parallel-link networks admit a PNE. Moreover, a PNE can be computed in polynomial time.

Milchtaich [63] proved that a parallel-link congestion game with general player-specific payoffs may not admit a potential function. In our case however, the players' individual costs are correlated with each other, as for any edge, there is a common distribution on which they depend. Nevertheless, we next show that parallel-link games with  $p$ -homogeneous stochastic players and linear latencies may not admit a potential function.

**Theorem 6.3.** There are Congestion Games with  $p$ -Homogeneous Stochastic Players on parallel-link networks with linear delays that do not admit a potential function.

*Proof.* It suffices to show that there is an infinite improvement cycle, i.e. an infinite sequence of deviations for which each deviating player perceives less cost. We will modify Milchtaich's counter-example ([63]) to fit our case. Since players have the same probability of participation  $p$ , the load on each edge  $e$  that player  $i$  considers is a binomial distribution:  $\sum_{j \neq i: e \in s_j} X_j$ .

Fix  $p = 0.75$ , and consider three edges,  $e_1, e_2$  and  $e_3$ , and three players that will deviate, with  $\delta_1 = 0.75$ ,  $\delta_2 = 0.58$  and  $\delta_3 = 0.6$ . Also, assume

that there are  $n_1 = 25$  extra players on  $e_1$ ,  $n_2 = 20$  extra players on  $e_2$  and  $n_3 = 9$  extra players on  $e_3$ . The latency functions of the edges are:  $f_1(k) = 3k + 71$ ,  $f_2(k) = 6k + 33$  and  $f_3(k) = 15k + 1$ .

In the following, an infinite better response cycle is described, consisting of six different configurations that interchangeably follow one another:

	$e_1$	$e_2$	$e_3$
i	{1, 2}	{3}	
ii	{1, 2}		{3}
iii	{2}		{1, 3}
iv		{2}	{1, 3}
v		{2, 3}	{1}
vi	{1}	{2, 3}	
	{1, 2}	{3}	

We will only write down (as a 3-dimensional vector, corresponding to players 1, 2 and 3) what load do the three players perceive on the edge they use in each step (excluding themselves):

**i.** (21, 20, 16)

**ii.** (21, 20, 7)

**iii.** (8, 19, 8)

**iv.** (8, 15, 8)

**v.** (8, 16, 16)

**vi.** (20, 16, 16)

The existence of the above infinite improvement cycle forbids the existence of any potential function.  $\square$

**$\delta$ -Homogeneous Stochastic Players.** In this case, players have the same confidence level  $\delta$ , but the participation probability  $p_i$  of each player  $i$  may be different. We next show how to efficiently compute a PNE in parallel-link networks. Specifically, we describe the  $p$ -Decreasing Greedy Best Response algorithm, or  $p$ DGBR in short, and show that it always results in a PNE:

- Sort players in *non-increasing* order of their  $p_i$ 's.
- Insert one player at a time, according to the previous order, to the edge that corresponds to her best response move.

- Repeat until all players are inserted.

**Theorem 6.4.** The **pDGBR** procedure computes a PNE for Congestion Games with Stochastic  $\delta$ -Homogeneous Players on parallel-link networks with general latency functions in time  $O(n \cdot m + n^2)$ .

*Proof.* The proof comes by induction on the number of players. The induction hypothesis is that before the next insertion we are at a PNE.

Assume that we are in the middle of the procedure, in a PNE, and player  $i$  has just chosen edge  $e$ . Players on other edges do not deviate because the only edge changed is  $e$  and it got an extra player. What remains to prove is that players on  $e$  do not deviate.

Let  $k$  be a player on  $e$ , inserted in a previous step ( $p_k \geq p_i$ ). In order to show that  $k$  doesn't deviate, it suffices to show that after step  $i$ , say under configuration  $s$  (with  $s_i = s_k = e$ ), we have that  $c_k(s) \leq c_i(s)$ , as edge  $e$  is a best response strategy for player  $i$  and the cost that  $i$  and  $k$  perceive on any other edge is the same.

Consider  $c_k(s)$  and  $c_i(s)$ . We have:

$$c_k(s) = \min \left\{ t : \Pr \left[ d_e(1 + X_i + \sum_{j \neq i, k: s_j = e} X_j) \leq t \right] \geq \delta \right\},$$

$$c_i(s) = \min \left\{ t : \Pr \left[ d_e(1 + X_k + \sum_{j \neq i, k: s_j = e} X_j) \leq t \right] \geq \delta \right\}.$$

Since  $p_k \geq p_i$ , for any  $r \in \mathbb{N}$ :

$$\begin{aligned} \Pr \left[ X_k + \sum_{j \neq i, k: s_j = e} X_j \leq r \right] &= \Pr \left[ \sum_{j \neq i, k: s_j = e} X_j \leq r \right] - \Pr \left[ \sum_{j \neq i, k: s_j = e} X_j = r \right] \cdot p_k \\ &\leq \Pr \left[ \sum_{j \neq i, k: s_j = e} X_j \leq r \right] - \Pr \left[ \sum_{j \neq i, k: s_j = e} X_j = r \right] \cdot p_i \\ &= \Pr \left[ X_i + \sum_{j \neq i, k: s_j = e} X_j \leq r \right]. \end{aligned}$$

Thus, since  $d_e$ 's are non decreasing,

$$\Pr \left[ d_e(1 + X_k + \sum_{j \neq i, k: s_j = e} X_j) \leq d_e(r + 1) \right] \leq \Pr \left[ d_e(1 + X_i + \sum_{j \neq i, k: s_j = e} X_j) \leq d_e(r + 1) \right]$$

and so  $c_k(s) \leq c_i(s)$ , as needed.

The total time needed for the procedure is  $O(n \cdot m + n^2)$ , as at each step  $i$ , the computations for the newly inserted player take  $O(m + i^2)$  time and we can use memoization to avoid recalculations.  $\square$

We can also show that games in this class admit a potential function, which can be thought of as a generalized lexicographic potential function in two dimensions.

**Theorem 6.5.** Congestion Games with Stochastic  $\delta$ -Homogeneous Players on parallel-link networks are potential games.

*Proof.* We will define a two dimensional lexicographic potential function. For that, we define, for each edge  $e$  and configuration  $s$ , a two dimensional vector  $v_{e,s}$  and a total order on these vectors. Right after, for  $s$ , we define a vector  $w_s$  that as components has exactly the vectors  $\{v_{e,s}\}_{e \in E}$  ordered increasingly (with the usual vector ordering). Any improvement step that turned the configuration from  $s$  to  $s'$  is such that  $w_s < w_{s'}$ . Any strictly decreasing function on vectors  $w_s$  works as (generalized) potential. Technical details follow.

Let  $c_e(s) = \min \left\{ t : \Pr[d_e(1 + N_e(s)) \leq t] \geq \delta \right\}$  be the *outside*  $\delta$ -cost of edge  $e$  under  $s$ , i.e. the cost that any player not in  $e$  computes for  $e$  when she considers moving to  $e$ . We have

$$c_e(s) = c_i(s_{-i}, e), \quad \forall i : s_i \neq e \quad (6.1)$$

$$c_e(s) \geq c_i(s), \quad \forall i : s_i = e. \quad (6.2)$$

Let  $v_{e,s} = (c_e(s), s_e)$  and consider the standard ordering on these pairs:

- $(x_1, y_1) < (x_2, y_2)$  iff  $x_1 < x_2$  or  $(x_1 = x_2$  and  $y_1 < y_2)$ .
- $(x_1, y_1) = (x_2, y_2)$  iff  $x_1 = x_2$  and  $y_1 = y_2$ .
- $(x_1, y_1) > (x_2, y_2)$  otherwise.

For a configuration  $s$ , let  $w_s$  be the vector that consists of the pairs  $\{v_{e,s}\}_{e \in E}$  in increasing order. We are going to show that after an improving step, the new configuration  $s'$  is such that  $w_s < w_{s'}$ .

Assume that player  $i$  did an improvement step by moving from  $e$  to  $e'$  and let  $s$  be the configuration with  $s_i = e$  and  $s'$  the configuration with  $s'_i = e'$ . Player  $i$  deviated because  $c_i(s) > c_i(s')$ . It is  $c_i(s') = c_i(s_{-i}, e') = c_{e'}(s)$  and, by (13.2),  $c_e(s) \geq c_i(s)$ . So, we get  $c_e(s) > c_{e'}(s)$ , which implies that

$$v_{e',s} < v_{e,s}.$$

Thus, if we consider the coordinates of  $w_s$ , we know that  $v_{e,s}$  is after  $v_{e',s}$  and so in order to show  $w_s < w_{s'}$ , it suffices to show that  $v_{e',s} < v_{e',s'}$  (inequality 13.3) and  $v_{e',s} < v_{e,s'}$  (inequality 13.4).

By the improving step, the only pairs that changed are  $v_{e,s}$  and  $v_{e',s}$ . In fact, it is  $s_e > s'_e$  and  $s_{e'} < s'_{e'}$ , and it might be  $c_e(s) > c_e(s')$  or  $c_{e'}(s) < c_{e'}(s')$ . Whichever is the case, we have:

$$v_{e',s} < v_{e',s'} \quad (6.3)$$

Because  $i$  did an improving step to  $e'$  and by  $s_i \neq e'$  and (13.1) we get  $c_i(s) > c_i(s_{-i}, e') = c_{e'}(s)$ . Also, by  $s'_i \neq e$  and (13.1) we get  $c_i(s) = c_i(s'_{-i}, e) = c_e(s')$ . Thus,  $c_{e'}(s) < c_e(s')$  and

$$v_{e',s} < v_{e,s'} \quad (6.4)$$

Let  $\Phi$  be any strictly decreasing function on  $w_s$ . Clearly, for any configuration  $s$ , any edges  $e, e'$  and any player  $i$  it is

$$c_i(s_{-i}, e) - c_i(s_{-i}, e') > 0 \Rightarrow \Phi(s_{-i}, e) - \Phi(s_{-i}, e') > 0$$

and thus  $\Phi$  is a generalized potential.  $\square$

### 6.2.3 Τμήμα της Αναρχίας σε Παίγνια με Αφινικές Συναρτήσεις

In Stochastic Congestion Games with Stochastic Players, the *social cost* of a configuration  $s$  is defined as  $C(s) = \mathbf{E}\left[\sum_{i \in N} X_i D_i(s)\right]$ , as this seems to be the most natural generalization of the definition of the Social Cost in standard atomic CGs.

Letting  $o$  denote an optimal configuration, i.e.  $c(o) = \min_s \{C(s)\}$ , the Price of Anarchy is formally defined as  $PoA = \max \left\{ \frac{C(s)}{C(o)} : s \text{ is a PNE} \right\}$ .

In the following we convert  $C(s)$  to a more convenient form and right after we give upper and lower bounds on the PoA for games with affine latency functions as the expected values related to the random distributions  $d_e(N_e(s))$  for general latency functions are hard to handle.

As already noted,  $D_i(s) = D_{s_i}(s)$  with  $X_i = 1$ , and so  $X_i \cdot D_i(s) = X_i \cdot D_{s_i}(s)$ . Thus,

$$C(s) = \mathbf{E}\left[\sum_{i \in N} X_i \cdot D_{s_i}(s)\right] = \sum_e \mathbf{E}[N_e(s) \cdot d_e(N_e(s))].$$

For affine latency functions of the form  $d_e(k) = a_e k + b_e$ , it is

$$C(s) = \sum_e \mathbf{E}[N_e(s) \cdot (a_e N_e(s) + b_e)] = \sum_e [a_e (\mathbf{E}[N_e(s)]^2 + \mathbf{Var}[N_e(s)]) + b_e \mathbf{E}[N_e(s)]].$$

**Theorem 6.6.** Congestion Games with Stochastic Players and affine latency functions on parallel-link networks have  $PoA = O(n)$ .



*Proof.* Let  $d_e(k) = a_e k + b_e$  denote the latency of an edge  $e$ . Two things should be pointed out for the proof.

i) The costs that players perceive on each edge is almost at least as large as it would be if they were considering as load the expectation of other players on each edge plus themselves, i.e.  $c_i(s) \geq a_e \mathbf{E}[\sum_{j: e=s_j} X_j] - a_e + b_e$ , for any  $s$  and  $i : s_i = e$ .

This is the case as, if we assume that edges have affine delay functions,  $d_e(k) = a_e k + b_e$ , then the cost that player  $i$  perceives for edge  $e$  under a configuration  $s$  with  $s_i = e$  is

$$\begin{aligned} c_i(s) &= \min \left\{ t \mid \Pr \left[ d_e \left( 1 + \sum_{j \neq i: e=s_j} X_j \right) \leq t \right] \geq \delta_i \right\} \\ &= \min \left\{ t \mid \Pr \left[ a_e \left( 1 + \sum_{j \neq i: e=s_j} X_j \right) + b_e \leq t \right] \geq \delta_i \right\} \\ &= a_e \left( 1 + \min \left\{ t \mid \Pr \left[ \sum_{j \neq i: e=s_j} X_j \leq t \right] \geq \delta_i \right\} \right) + b_e. \end{aligned}$$

For the median and the mean of the random variable  $\sum_{j \neq i: e=s_j} X_j$  it is (see e.g [80])

$$\left| \mathbf{E} \left[ \sum_{j \neq i: e=s_j} X_j \right] - \min \left\{ t \mid \Pr \left[ \sum_{j \neq i: e=s_j} X_j \leq t \right] \geq 1/2 \right\} \right| \leq 1.$$

Thus, for player  $i : s_i = e$ ,

$$\begin{aligned} c_i(s) &\geq a_e \left( 1 + \min \left\{ t \mid \Pr \left[ \sum_{j \neq i: e=s_j} X_j \leq t \right] \geq 1/2 \right\} \right) + b_e \\ &\geq a_e \mathbf{E} \left[ \sum_{j \neq i: e=s_j} X_j \right] + b_e \geq a_e \mathbf{E} \left[ \sum_{j: e=s_j} X_j \right] - a_e + b_e \end{aligned}$$

ii) At equilibrium, all players on the used edges perceive a cost not greater than  $n(a + b)$ , where  $a + b = \min_e \{a_e + b_e\}$ .

This is the case, or else a player that perceives a greater cost would have an incentive to deviate to the edge  $e$  with  $d_e(k) = ak + b$ .

To prove the theorem, let  $f$  be a Nash equilibrium and  $o$  be an optimal configuration. We wish to bound the cost of  $f$ ,  $C(f)$ , by a factor of the form  $n \cdot C(o)$ .

Denote  $F_e \equiv N_e(f)$  and  $O_e \equiv N_e(o)$ . We have

$$\begin{aligned} C(f) &= \sum_e \left( a_e (\mathbf{E}[F_e]^2 + \mathbf{Var}[F_e]) + b_e \mathbf{E}[F_e] \right) = \sum_e \mathbf{E}[F_e] \left( a_e \mathbf{E}[F_e] + b_e + a_e \frac{\mathbf{Var}[F_e]}{\mathbf{E}[F_e]} \right) \\ &\leq \sum_e \mathbf{E}[F_e] \left( c_{max} + a_e + a_e \frac{\mathbf{Var}[F_e]}{\mathbf{E}[F_e]} \right) \leq 3 \sum_e \mathbf{E}[F_e] c_{max}. \end{aligned}$$

where  $c_{max}$  is the greatest cost that a player perceives under  $f$ . The inequalities follow from point (i) above,  $c_{max} \geq a_e$  for all  $e$  under use and  $\frac{\mathbf{Var}[F_e]}{\mathbf{E}[F_e]} \leq 1$ .

From point (ii) above, with  $a + b = \min_e\{a_e + b_e\}$ , we get that

$$\begin{aligned} C(f) &\leq 3c_{max} \sum_e \mathbf{E}[F_e] \leq 3n(a + b) \sum_e \mathbf{E}[F_e] = 3n(a + b) \sum_{i \in N} p_i \\ &= 3n(a + b) \sum_e \mathbf{E}[O_e] \leq 3n \sum_e \mathbf{E}[O_e](a_e + b_e) \\ &\leq 3n \sum_e \mathbf{E}[O_e] \left( a_e \frac{\mathbf{E}[O_e]^2 + \mathbf{Var}[O_e]}{\mathbf{E}[O_e]} + b_e \right) = 3nC(o). \end{aligned}$$

The last inequality follows by  $\frac{\mathbf{E}[O_e]^2 + \mathbf{Var}[O_e]}{\mathbf{E}[O_e]} = \frac{\mathbf{E}[O_e^2]}{\mathbf{E}[O_e]} \geq 1$ .  $\square$

Next, we give a class of fully symmetric games with stochastic players, on singleton strategies and linear latency functions, that has  $PoA = \Omega(n)$ .

**Theorem 6.7.** There are Congestion Games with Homogeneous Players that have  $PoA = \Omega(n)$ .

*Proof.* Let  $k \in \mathbb{N}$ . Consider the parallel links game with  $n$  players and  $k + 1$  edges. The first edge,  $e_1$ , has delay function  $d_1(x) = x$  and the others,  $e_2, \dots, e_{k+1}$ , have  $d_j(x) = (n - k)x$ ,  $j = 2, \dots, k + 1$ . Players play with (common) probability  $p$  and are fearful, i.e. all of them have  $\delta = 1$ , and so they consider that all players on their edge use it.

Let  $f$  be the configuration where  $n - k$  players are on  $e_1$  and the other  $k$  players are one on each of the  $k$  remaining edges. This is a PNE, since each player perceives a cost of  $n - k$ .

All edges  $\{e_i\}_{i=1 \dots k+1}$  have  $b_{e_i} = 0$ . So, the social cost of  $f$  is

$$C(f) = \sum_e [a_e(\mathbf{E}[N_e(f)]^2 + \mathbf{Var}[N_e(s)])]$$

For  $e_1$  it is:  $a_{e_1}(\mathbf{E}[N_{e_1}(f)]^2 + \mathbf{Var}[N_{e_1}(s)]) = (n - k)^2 p^2 + (n - k)p(1 - p)$

For all  $e \in \{e_i\}_{i=2 \dots k+1}$  it is:  $a_e(\mathbf{E}[N_e(f)]^2 + \mathbf{Var}[N_e(s)]) = p(n - k)$ .

So

$$C(f) = (n - k)^2 p^2 + (n - k)p(1 - p) + kp(n - k).$$

Now let configuration  $o$  be the one in which every player plays  $e_1$ . It is

$$C(o) = n^2 p^2 + np(1 - p)$$

So, for  $k = \frac{n}{2}$  and  $p = \frac{1}{n}$

$$PoA \geq \frac{C(f)}{C(o)} = \frac{(n-k)^2 p^2 + (n-k)p(1-p) + kp(n-k)}{n^2 p^2 + np(1-p)} = \frac{1}{2} + \frac{n-1}{8 - \frac{4}{n}} = \Omega(n),$$

as needed.  $\square$

## 6.3 Παίγνια Συμφοράς με Στοχαστικές Ακμές

### 6.3.1 Το Μοντέλο

In Congestion Games with Stochastic Edges, players are deterministic, i.e. they always participate in the game and are represented only by their confidence levels  $\delta_i$ . On the other hand, edges have a stochastic behavior. For an edge  $e$ , its latency function is an independent random variable:

$$d_e(k) = \begin{cases} f_e(k), & \text{with probability } 1 - p_e \\ g_e(k), & \text{with probability } p_e. \end{cases}$$

The cost of an edge  $e$  with load  $k$  is:  $X_e(k) = (1 - p_e) \cdot f_e(k) + p_e \cdot g_e(k)$  and the cost of a player  $i$  with strategy  $s_i$ , is the random variable:  $D_i(s) = \sum_{e \in s_i} X_e(s_e)$

The cost that player  $i$  perceives is:  $c_i(s) = \min \left\{ t \mid \Pr [D_i(s) \leq t] \geq \delta_i \right\}$

and the *social cost* of a configuration  $s$  is defined as:  $C(s) = \mathbf{E} \left[ \sum_{i \in N} D_i(s) \right]$ , i.e. similar to the stochastic players case.

**Classes of congestion games.** Here we only define two classes of congestion games with stochastic edges:

- *homogeneous*, where all players have the same  $\delta_i$ 's.
- *heterogeneous*, where players may have different  $\delta_i$ 's.

The class of congestion games with stochastic edges and homogeneous players boils down to the class of potential games, while the class of congestion games with stochastic edges and heterogeneous players boils down to the class of congestion games with *player specific cost functions* ([63]).

### 6.3.2 Στοχαστικές Ακμές σε Δίκτυο Παραλλήλων Ακμών: Ύπαρξη και υπολογισμός PNE

In the following, we restrict ourselves to Congestion Games with Stochastic Edges on parallel-link networks, and investigate the existence and the efficient computation of PNE for the two cases considered above.

**Homogeneous Stochastic Players.** If the players are homogeneous, stochastic congestion games on parallel-links are equivalent to standard congestion games on parallel-links (but with possibly different latencies), because the (risk-averse) individual cost of each player in a configuration  $s$  depends only on the link  $e$  and its congestion  $s_e$ .

**Theorem 6.8.** Stochastic Congestion Games with Stochastic Edges and Homogeneous Players on parallel-link networks are potential games. Moreover, a PNE can be computed in time  $O(n \cdot m)$ .

*Proof.* Recall that  $D_i(s) = \sum_{e \in s_i} X_e(s_e)$  and the cost that players perceive is  $c_i(s) = \min \left\{ t \mid \Pr [D_i(s) \leq t] \geq \delta_i \right\}$  and observe that since players have the same  $\delta$ , the cost that any player  $i$  perceives on edge  $e$  when there are  $s_e$  players in total on edge  $e$  is the same for all  $i$ , and equal to:

$$c_e(s_e) = \begin{cases} f_e(s_e), & \text{if } 1 - p_e \geq \delta \\ g_e(s_e), & \text{otherwise} \end{cases}$$

We now define the standard potential function:

$$\Phi(s) = \sum_e \sum_{j=1}^{s_e} c_e(s)$$

It is easy now to verify that the above function is indeed an exact potential function. Observe that there is no restriction for  $p_e, f_e(n)$  and  $g_e(n)$ .

Regarding the computation of a PNE, we can again use a standard *Greedy Best Response* algorithm. We insert the players in the game, one by one, and the player just inserted does a best response move. Since all players perceive the same costs, it is clear that at each step we have a PNE, and so, when the procedure terminates, we are still in a PNE. As for the time needed, at each step the calculation of the best response move takes time  $O(m)$ , and so the total time needed is  $O(n \cdot m)$ .  $\square$

**Heterogeneous Stochastic Players.** In this case, a stochastic game is equivalent to a congestion game on parallel links with player-specific payoffs [63], as the (risk-averse) individual cost of each player in a configuration  $s$  depends only on the link  $e$ , its congestion  $s_e$ , and  $i$ 's confidence level  $\delta_i$ . Thus, we obtain:

**Corollary 6.9.** Congestion Games with Heterogenous Stochastic Players and Stochastic Edges on parallel-link networks admit a PNE. Moreover, a PNE can be computed in polynomial time.

In ([63]) it is proved that congestion games with player specific payoff functions always possess a PNE. We now prove that the class of Congestion Games with Stochastic Edges does not admit any kind of potential, even if we restrict ourselves to affine latency functions.

**Theorem 6.10.** There is no potential function for the class of Congestion Games with Stochastic Edges and deterministic risk-averse players.

*Proof.* We consider 3 players and 3 links, with the same “failure” probabilities. The latency functions are:

$$f_1(k) = \begin{cases} 3k + 21, & \text{with probability 0.8} \\ 5k + 22, & \text{with probability 0.2} \end{cases}$$

$$f_2(k) = \begin{cases} 6k + 16, & \text{with probability 0.8} \\ 22k + 5, & \text{with probability 0.2} \end{cases}$$

$$f_3(k) = \begin{cases} k + 24, & \text{with probability 0.8} \\ 25k + 1, & \text{with probability 0.2} \end{cases}$$

Players 1 and 2 have confidence level  $\delta_1 = \delta_2 = 0.7$  and player 3 has confidence level  $\delta_3 = 0.9$ . We now construct the following cycle:

$e_1$	$e_2$	$e_3$
{1, 2}	{3}	
{1, 2}		{3}
{2}		{1, 3}
	{2}	{1, 3}
	{2, 3}	{1}
{1}	{2, 3}	
{1, 2}	{3}	

One can verify that this is a better response cycle and thus no potential function exists.  $\square$

### 6.3.3 Τμήμα της Αναρχίας

The risk aversion of the players combined with their selfish behavior may give unlimited degradation to the network.

**Theorem 6.11.** There are Stochastic Congestion Games with Stochastic Edges that have unbounded PoA.

*Proof.* We will use a simple network with two parallel edges and two players:

$$f_1(k) = \begin{cases} ak + 1, & \text{with probability } 0.50 + \epsilon \\ Ak + 1, & \text{with probability } 0.50 - \epsilon, \end{cases}$$

$$f_2(k) = 2ak + 1 + \epsilon, \text{ with probability } 1.$$

(Assume that  $\epsilon < 1/2$ .)

Both players have confidence level  $\delta_1 = \delta_2 = \delta = 0.5$ . We assume that  $A > 2a$ . As a result, both players “see” the good part of edge  $e_1$ , and so they both prefer it. Let  $s = (e_1, e_1)$  be the configuration vector of the PNE. The social cost of  $s$  is  $C(s) = 2[(2a + 1)(0.5 + \epsilon) + (2A + 1)(0.5 - \epsilon)]$ , while an optimal configuration is  $o = (e_2, e_2)$  with social cost  $C(o) = 2(4a + 1 + \epsilon)$ . We have:

$$\begin{aligned} PoA &= \frac{C(s)}{C(o)} = \frac{2[(2a + 1)(0.5 + \epsilon) + (2A + 1)(0.5 - \epsilon)]}{2(4a + 1 + \epsilon)} \\ &= \frac{(2a + 1)(0.5 + \epsilon)}{4a + 1 + \epsilon} + \frac{(2A + 1)(0.5 - \epsilon)}{4a + 1 + \epsilon} \\ &\geq \frac{(0.5 - \epsilon)(2A + 1)}{4a + 1 + \epsilon} \\ &\geq \frac{(0.5 - \epsilon)2A}{4a + 1 + \epsilon} \\ &\geq \frac{(0.5 - \epsilon)A}{2a + 1} \end{aligned}$$

Thus,  $PoA \rightarrow \infty$ , if  $\frac{(0.5 - \epsilon)A}{2a + 1} \rightarrow \infty$  (e.g.  $\epsilon < 0.4$  and  $\frac{A}{2a + 1} \rightarrow \infty$ ).

□

## Κεφάλαιο 7

# Χρησιμοποιώντας Τυχαιότητα προς Ύψος του Συνόλου

Στο κεφάλαιο αυτό εξετάζουμε κατά πόσο κάποιος μπορεί να εκμεταλλευτεί την εγωιστική συμπεριφορά των παικτών και να μετατρέψει τα κόστη που υπολογίζουν οι παίκτες στις ακμές ώστε το τίμημα της αναρχίας, με βάση τις πραγματικές συναρτήσεις κόστους, να βελτιωθεί. Το σημείο εκκίνησης είναι να εισάγουμε κάποιες μικρές και προσεκτικά επιλεγμένες τυχαίες μεταβολές στις συναρτήσεις των παικτών έτσι ώστε η μέση καθυστέρηση να μην αλλάζει στις ακμές, αλλά το κόστος που υπολογίζουν οι παίκτες να αυξάνονται λόγω του φόβου τους απέναντι στο ρίσκο. Για να δώσουμε ένα απλό και γενικό θεωρητικό μοντέλο εισάγουμε τα  $\gamma$ -*modifiable* παίγνια συμφόρησης όπου οι συναρτήσεις καθυστέρησης μιας ακμής  $e$  μπορούν να αλλάξουν από  $l_e(x)$  σε  $(1 + \gamma_e)l_e(x)$ , για κάποιο επιλεγμένο  $\gamma_e \in [0, \gamma]$ . Για  $\gamma$ -*modifiable* παίγνια σε δίκτυα παραλλήλων ακμών και σε σειριακά παράλληλα δίκτυα, χαρακτηρίζουμε πλήρως τις τιμές του  $\gamma$  για τις οποίες  $\gamma$ -περιορισμένων μεταβολές μπορούν να μειώσουν το PoA στο 1. Επιπλέον δείχνουμε ότι μπορούμε (αποδοτικά) να υπολογίσουμε ένα σύνολο  $\gamma$ -περιορισμένων μεταβολών ούτως ώστε το PoA στο εναπομείνον παίγνιο να μειώνεται σημαντικά όσο το  $\gamma$  αυξάνεται. Για παράδειγμα, για γραμμικές συναρτήσεις το PoA είναι το πολύ  $\max\{1, (1 - (1 - \gamma)^2/4)^{-1}\}$ . Επίσης αποδεικνύουμε ότι η ανάλυση για το PoA είναι σφιχτή, ακόμη και για παίγνιο σε δύο παράλληλες ακμές ενώ ταυτόχρονα συζητούμε την δυσκολία επέκτασης των χαρακτηρισμών μας και των κατασκευών μας σε παίγνια με γενικότερα δίκτυα.

## 7.1 Εισάγοντας τα $\gamma$ – *modifiable* Παίγνια Συμφόρησης

In order to introduce  $\gamma$ -modifiable CGs, we first discuss how (typically small) random perturbations in the edge latencies can be performed so that the expected latency does not change, but the latency perceived by the players increases, due to risk aversion. E.g., let us consider an edge  $e$  with latency function  $d_e(x)$  where we can increase the latency temporarily up to  $(1 + a_1)d_e(x)$  and decrease it temporarily (and for relatively short time intervals) up to  $(1 - a_2)d_e(x)$ . If we implement the former change with probability  $p_1$  and the latter with probability  $p_2 < 1 - p_1$  (the probabilities here essentially correspond to proportions of time in which  $e$  operates in each state), the latency function of  $e$  in a given time step is a random variable  $\ell_e(x)$  with expectation:

$$\mathbf{E}[\ell_e(x)] = [p_1(1 + a_1) + p_2(1 - a_2) + (1 - p_1 - p_2)]d_e(x)$$

Adjusting  $p_1$  and  $p_2$  (and possibly  $a_1$  and  $a_2$ ) so that  $p_1 a_1 = p_2 a_2$ , we have  $\mathbf{E}[\ell_e(x)] = d_e(x)$ , i.e., for any given flow, the expected delay through  $e$  does not change. On the other hand, if the players are risk-averse and their individual cost is given by an  $(1 - p_1 + \varepsilon)$ -quantile of the delay distribution (e.g., as in [68, 6]), for some  $\varepsilon > 0$ , the latency perceived by the players on  $e$  is  $(1 + a_1)d_e(x)$ . Similarly, if the individual cost of the risk-averse players are given by the expectation plus the standard deviation of the delay distribution (e.g., as in [67]), the latency perceived by the players on  $e$  is  $(1 + \sqrt{p_1 a_1^2 + p_2 a_2^2})d_e(x)$ . In both cases, we can have a significant increase in the latency perceived by the risk-averse players on  $e$ , while the expected latency remains unchanged. A similar result could be achieved with any latency distribution on  $e$  (possibly more sophisticated and with larger support), as long as its expectation is  $d_e(x)$ .

In most practical situations, the increase and, especially, the decrease in the latency functions that can be implemented are bounded (and relatively small). The same is particularly true for the proportion of time in which an edge can operate in an “abnormal” state of increased or decreased latency. Combined with the formula providing the individual cost of the risk-averse players, these factors determine an upper bound  $\gamma_e$  on the multiplicative increase of the latency perceived by the players on each edge  $e$ . Thus, motivated by such considerations, we introduce the so-called  *$\gamma$ -modifiable selfish routing games* as a simple and general abstraction of how one can exploit risk-aversion towards improving the PoA of selfish routing.

**$\gamma$ -Modifiable Routing Games.** A selfish routing game  $\mathcal{G} = (G, d, r)$  is  *$\gamma$ -modifiable* if for each edge  $e \in G$ , we can choose a  $\gamma_e \in [0, \gamma]$  and change the



edge latency functions perceived by the players from  $d_e(x)$  to  $(1+\gamma_e)d_e(x)$  by small random perturbations, as discussed above. Any vector  $\Gamma = (\gamma_e)_{e \in E}$ , where  $\gamma_e \in [0, \gamma]$  for each edge  $e$ , is called a  $\gamma$ -modification of  $\mathcal{G}$ . Given a  $\gamma$ -modification  $\Gamma$ , we let  $\mathcal{G}^\Gamma$  denote the  $\gamma$ -modified routing game  $\mathcal{G}^\Gamma = (G, (1+\Gamma)d, r)$ , with a latency function  $(1+\gamma_e)d_e(x)$  on each edge  $e$ , obtained from  $\mathcal{G}$ . To simplify notation, we sometimes write  $G^\Gamma$ , instead of  $\mathcal{G}^\Gamma$ .

Given a flow  $f$ , the latency perceived by the players on a path  $p$  in  $\mathcal{G}^\Gamma$  is calculated wrt the modified latencies and is equal to  $d_p^\Gamma(f) = \sum_{e \in p} (1 + \gamma_e)d_e(f_e)$ <sup>1</sup>. A flow  $f$  is a *Nash flow* for the modified game, if it routes all traffic on minimum perceived latency paths, i.e., if for every path  $p$  with  $f_p > 0$ , and every path  $p'$ ,  $d_{p'}^\Gamma(f) \leq d_p^\Gamma(f)$ . Again, to simplify notation, we usually write  $d_p(f)$ , instead of  $d_p^\Gamma(f)$ , as long as it is clear from the context that the path latencies are wrt. the modified game  $\mathcal{G}^\Gamma$ .

Given a routing game  $\mathcal{G}$ , we say that a flow  $f$  is  $\gamma$ -enforceable, or simply *enforceable*, if there exists a  $\gamma$ -modification  $\Gamma$  of  $\mathcal{G}$  such that  $f$  is a Nash flow of  $\mathcal{G}^\Gamma$ .

We always assume that  $\gamma$ -modifications keep the expected latency functions unchanged. Since for any flow  $f$ , the expected latency of any edge  $e$  in  $\mathcal{G}^\Gamma$  is equal to the latency of  $e$  in  $\mathcal{G}$  under  $f$ , the (expected) total latency of  $f$  in both  $\mathcal{G}^\Gamma$  and  $\mathcal{G}$  is equal to  $C(f) = \sum_{e \in E} f_e d_e(f_e)$ . Hence, the optimal flow  $o$  of  $\mathcal{G}$  is also an optimal flow of  $\mathcal{G}^\Gamma$ .

The Price of Anarchy  $\text{PoA}(\mathcal{G}^\Gamma)$  of the modified game  $\mathcal{G}^\Gamma$  is equal to  $C(f)/C(o)$ , where  $f$  is the Nash flow of  $\mathcal{G}^\Gamma$ . For a  $\gamma$ -modifiable game  $\mathcal{G}$ , the Price of Anarchy of  $\mathcal{G}$  under  $\gamma$ -modifications, denoted  $\text{PoA}_\gamma(\mathcal{G})$ , is the best PoA that we can achieve by some  $\gamma$ -modification. Formally,  $\text{PoA}_\gamma(\mathcal{G}) = \min\{\text{PoA}(\mathcal{G}^\Gamma) \mid \Gamma \text{ is a } \gamma\text{-modification of } \mathcal{G}\}$ . For routing games with cost functions in a class  $\mathcal{D}$ ,  $\text{PoA}_\gamma(\mathcal{D})$  denotes the maximum  $\text{PoA}_\gamma(\mathcal{G})$  over all  $\gamma$ -modifiable games  $\mathcal{G}$  with latency functions in class  $\mathcal{D}$ .

**Connection to Marginal-Cost Tolls.** A sufficient condition for the optimal flow to be  $\gamma$ -enforceable can be obtained through optimal marginal-cost tolls, that assign an additive toll of  $o_e d'_e(o_e)$  to any edge  $e$  (see e.g., [77]).

**Proposition 8.** *Let  $o$  be the optimal flow of a  $\gamma$ -modifiable instance  $\mathcal{G}$ . If for all links  $e$  with  $o_e > 0$ ,  $\frac{o_e d'_e(o_e)}{d_e(o_e)} \leq \gamma$ , then  $o$  is  $\gamma$ -enforceable in  $\mathcal{G}$ .*

<sup>1</sup>To simplify the model and make it easily applicable to general networks, we make the convenient assumption that the latency modifications (and the resulting individual costs of the players) are separable, although most common notions of individual cost for risk-averse players result in non-separable costs (see e.g., [72, 68, 67, 6], but see also [71], where the simplifying assumption of independence among randomized schedulers of different edges also implies the separability of individual costs). The separable costs assumption only affects the extension of our results to series-parallel networks.

*Proof.* For each edge  $e$  with  $o_e > 0$  (and thus, with  $d_e(o_e) > 0$ ), we let  $\gamma_e = \frac{o_e d'_e(o_e)}{d_e(o_e)}$ , while for each edge  $e$  with  $o_e = 0$ , we let  $\gamma_e = 0$ . By hypothesis, this defines a  $\gamma$ -modification  $\Gamma$  of  $\mathcal{G}$ . Moreover, if we change the latency functions of  $\mathcal{G}$  from  $d_e(x)$  to  $d_e(x) + x d'_e(x) = (1 + \gamma_e) d_e(x)$ , for all edges  $e$ , [77, Cor. 2.4.6] implies that the optimal flow  $o$  of  $\mathcal{G}$  is a Nash flow of the modified game  $\mathcal{G}^\Gamma$ .  $\square$   $\square$

Proposition 16 demonstrates that our approach is applicable to any routing game. Moreover, if  $\mathcal{G}$  has polynomial latency functions of degree  $d$ , then the optimal flow is  $\gamma$ -enforceable for any  $\gamma \geq d$ . However, Proposition 16 only provides a necessary condition and does not fully characterize the class of  $\gamma$ -modifiable routing games for which the optimal flow is enforceable (see also Section 14.2). Thus, we develop, in the next sections, a complete characterization of  $\gamma$ -modifiable routing games in parallel-link and in series-parallel networks with  $\gamma$ -enforceable optimal flows.

## 7.2 Πειράζοντας τα Παιγνία σε Δίκτυα Παραλλήλων Ακμών

We proceed to study  $\gamma$ -modifiable instances in parallel-link networks. We first deal with the question of characterizing the  $\gamma$ -modifiable instances where we can enforce the optimal flow. Then, we provide matching upper and lower bounds on the  $PoA_\gamma$  for  $\gamma$ -modifiable instances where the optimal flow is not enforceable. We also show how to compute  $\gamma$ -modifications that guarantee these  $PoA_\gamma$  bounds.

We note that the converse of Proposition 16 is not necessarily true. E.g., let us consider a  $\frac{1}{2}$ -modifiable instance  $\mathcal{G}$  on 2 parallel links with  $d_1(x) = x$ ,  $d_2(x) = x + 2$  and  $r = 3$ . The optimal flow is  $o = (2, 1)$ , and thus, enforceable in  $\mathcal{G}$ . On the other hand, the ratios of the marginal cost tolls to the optimal latencies are 1 and 1/4, for links 1 and 2, respectively. Hence, Proposition 16 only ensures that the optimal flow is enforceable if  $\mathcal{G}$  is 1-modifiable. Therefore, we proceed to develop a characterization of  $\gamma$ -modifiable games for which the optimal flow is enforceable.

**Theorem 7.1.** Let  $\mathcal{G}$  be a  $\gamma$ -modifiable game on parallel links and let  $o$  be the optimal flow of  $\mathcal{G}$ . The following are equivalent:

- (i)  $o$  is  $\gamma$ -enforceable in  $\mathcal{G}$ .
- (ii) for all links  $e, e' \in E$  with  $o_e > 0$ ,  $d_e(o_e) \leq (1 + \gamma) d_{e'}(o_{e'})$ .

*Proof.* (i)  $\rightarrow$  (ii): Let  $\Gamma = (\gamma_e)_{e \in E}$  be a  $\gamma$ -modification that makes  $o$  the Nash flow of  $\mathcal{G}^\Gamma$  and consider a pair of edges  $e$  and  $e'$ . Assume w.l.o.g. that

$d_{e'}(o_{e'}) \leq d_e(o_e)$  and  $o_e > 0$ . Flow  $o$  is a Nash flow in the modified network and thus  $(1 + \gamma_e)d_e(o_e) \leq (1 + \gamma_{e'})d_{e'}(o_{e'})$  which directly implies

$$d_e(o_e) \leq (1 + \gamma_e)d_e(o_e) \leq (1 + \gamma_{e'})d_{e'}(o_{e'}) \leq (1 + \gamma)d_{e'}(o_{e'})$$

(ii)  $\rightarrow$  (i): Assume that for any pair of edges  $e$  and  $e'$ , if  $o_e > 0$  then  $d_e(o_e) \leq (1 + \gamma)d_{e'}(o_{e'})$ . Let  $d_{max} = \max_e\{d_e(o_e) | o_e > 0\}$  be the maximum cost between all used edges under  $o$ . Assign for each edge  $e$  with  $o_e > 0$ ,  $\gamma_e = \frac{d_{max} - d_e(o_e)}{d_e(o_e)}$ . It is  $\gamma_e \leq \gamma$ , for all  $e$ , as by hypothesis  $d_{max} \leq (1 + \gamma)d_e(o_e)$ , for all  $e$ . Assign for each edge  $e$  with  $o_e = 0$ ,  $\gamma_e = 0$ . Let  $\Gamma = (\gamma_e)_{e \in E}$ . It is  $\forall e : o_e > 0 \Rightarrow (1 + \gamma_e)d_e(o_e) = d_{max}$ . Moreover,  $\forall e' : o_{e'} = 0 \Rightarrow d_{e'}(o_{e'}) \geq d_{max}$  as by (e.g.) corollary 2.4.6 in [77], for an  $e' : o_{e'} = 0$  and an  $e : o_e > 0$  and  $d_e(o_e) = d_{max}$ , it is  $d_{e'}(o_{e'}) \geq d_e(o_e) + o_e d'_e(o_e) \geq d_{max}$ . Thus  $o$  is a Nash flow in  $\mathcal{G}^\Gamma$ .  $\square$

Next, in the following Lemma, for any  $\gamma$ -modifiable instance  $\mathcal{G}$  with optimal solution  $o$ , we prove the existence of a pair  $(f, \Gamma)$  with specific suitable properties. This Lemma is the key both for proving the bound on the  $PoA_\gamma$  and guaranteing an efficient computation of a pair  $(f, \Gamma)$  that falls in that bound.

**Lemma 7.2.** Let  $\mathcal{G} = (G, d, r)$  be a parallel-links  $\gamma$ -modifiable instance and let  $o$  be the optimal flow of  $\mathcal{G}$ . There is a feasible flow  $f$  and a  $\gamma$ -modification  $\Gamma$  of  $\mathcal{G}$  such that

- i)  $f$  is a Nash flow in  $\mathcal{G}^\Gamma$ .
- ii) for any edge  $e$ : if  $f_e < o_e$  then  $\gamma_e = 0$  and if  $f_e > o_e$  then  $\gamma_e = \gamma$ .

*Proof.* Consider  $\mathcal{G} = (G, d, r)$  and its optimal solution  $o$ . If  $o$  can be  $\gamma$ -enforced, then by definition, there is a  $\gamma$ -modification  $\Gamma$  for which  $o$  is the Nash flow of  $\mathcal{G}^\Gamma$ . Thus for  $f = o$  and the above  $\Gamma$ , the Lemma holds. For all other cases we will use induction on the number of edges in  $G$ .

In the base case of a single edge, under any rate  $r$ ,  $f$  and  $o$  coincide and thus under any modification, the Lemma holds.

For the inductive step let  $e_m$  be a used edge with maximum cost under  $o$ . Remove  $e_m$  from the network, remove the flow through  $e_m$ , i.e.  $o_{e_m}$ , and let the instance  $\mathcal{G}_m = (G_m, d, r' = r - o_e)$  denote the new instance. For  $\mathcal{G}_m$ , by induction hypothesis, the Lemma holds. Thus there is a flow  $f'$  and a  $\gamma$ -modification  $\Gamma' = (\gamma'_e)_{e \in E_m}$  of  $\mathcal{G}_m$  such that: i)  $f'$  is the Nash flow in  $\mathcal{G}_m^{\Gamma'}$ , ii) for any edge  $e$ : if  $f'_e < o'_e$  then  $\gamma'_e = 0$  and if  $f'_e > o'_e$  then  $\gamma'_e = \gamma$ , where  $o'$  is the optimal solution of  $\mathcal{G}_m$ .

Now we will put back edge  $e_m$  and the removed flow. If there is a  $\gamma_{e_m}$  so as  $(1 + \gamma_{e_m})d_{e_m}(o_{e_m}) = L(G_m, (1 + \Gamma')d, r')$  then we can add  $\gamma_{e_m}$  to  $\Gamma'$  and

get  $\Gamma$  and the Lemma will hold for  $\mathcal{G}^\Gamma$ , with  $f$  being such that  $f_{e_m} = o_{e_m}$  and  $f_e = f'_e$  for all other edges. Else it should be  $d_{e_m}(o_{e_m}) > L(G_m, (1 + \Gamma')d, r')$  as for any used edge  $e$  under  $f'$ , with  $f'_e < o_e$ , it is  $d_e(f'_e) \leq d_e(o_e) \leq d_{e_m}(o_{e_m})$  and for any used edge  $e'$  with  $f'_{e'} \geq o_{e'}$  it is  $d_{e'}(f'_{e'}) = (1 + \gamma'_{e'})d_{e'}(f'_{e'}) \geq d_{e'}(f'_{e'})$  by properties *i*) and *ii*) of the induction hypothesis.

It remains to handle the case  $d_{e_m}(o_{e_m}) > L(G_m, (1 + \Gamma')d, r')$ . Intuitively we will reroute flow from  $e_m$  to the rest of the edges so as the equilibrium property in  $G_m$  is not destroyed. Our final goal is to make  $e_m$  cost equal to the Nash flow cost of  $G_m$ . During this procedure though, we have to be careful also not to destroy property *ii*). This could happen if we carelessly push flow to edges of  $G_m$  with  $f'_e < o_e$ . To take care of this, while rerouting, if such an edge  $e$  gets flow equal to  $o_e$  we stop rerouting through it but, in order to keep the equilibrium property, we unlock its  $\gamma_e$  and change its value<sup>2</sup> until it becomes  $\gamma$ . It also may be that during this procedure  $e_m$  gets empty of flow but this case is covered by the induction hypothesis for the instance  $(G_m, r)$ . Details follow.

Let  $0 \leq x_m \leq o_{e_m}$  be the maximum value (amount of flow) such that:

(a) there exist a  $\gamma$ -modification  $\Gamma^*$  of  $G_m$  such that under flow  $r' + x$ , the Nash flow  $f^*$  of  $G_m^{\Gamma^*}$  is such that for any edge  $e \in G_m^{\Gamma^*}$ : if  $f'_e \geq o_e$  and  $\gamma'_e = \gamma$  then  $f^*_e \geq f'_e > o_e$  and  $\gamma^*_e = \gamma (= \gamma'_e)$ , if  $f'_e < o_e$  then  $f'_e \leq f^*_e \leq o_e$  and  $\gamma^*_e = 0 (= \gamma_e)$ , if  $f'_e = o_e$  and  $\gamma'_e < \gamma$  then  $f^*_e = o_e (= f'_e)$  and  $\gamma^*_e \leq \gamma'_e \leq \gamma$ .

(b)  $d_{e_m}(o_{e_m} - x_m) \geq L(G_m, (1 + \Gamma^*)d, r' + x_m)$

It is  $x_m > 0$ . To see this, let  $E_{lock}$  be the set of edges that have  $f'_e = o_e$  and  $\gamma'_e < \gamma$  and  $E_{free}$  the rest of the used edges under  $f'$ . For  $\epsilon$  small enough, because of continuity, we can reroute flow from  $e_m$  to edges in  $E_{free}$  so as the equilibrium property in  $E_{free}$  is kept, the inequalities of (a) hold and these edges remain in  $E_{free}$ , with the inequality of their new flow with  $o_e$  having the same direction. By continuity and for  $\epsilon$  small enough, we can also grow (until the value  $\gamma$ ) the  $\gamma_e$ 's of the edges in  $E_{lock}$  so as the equilibrium property holds in  $E_{lock}$ . Combining these facts we can reroute an amount of flow  $\epsilon$  from  $e_m$  to edges in  $E_{free}$  and allowably change some of the  $\gamma_e$  values of edges in  $E_{lock}$  so as the equilibrium property in  $G_m$  is kept with inequality (b) still holding (recall that (b) was not tight).

By the same reasoning, unless (b) is tight or  $x_m = o_{e_m}$ , it should be that: (I) for  $x_m$  and its corresponding  $\Gamma^*$  and  $f^*$  there exists an  $e$  such that  $[(f'_e < o_e \text{ and } f^*_e = o_e \text{ and } \gamma^*_e = 0 (= \gamma_e)) \text{ or } (\gamma'_e < \gamma \text{ and } f^*_e = o_e (= f'_e) \text{ and } \gamma^*_e = \gamma)]$ . This means that either an edge in  $E_{free}$  under  $f'$  with  $f'_e < o_e$  will get in  $E_{lock}$  under  $f^*$  by gaining flow or an edge in  $E_{lock}$  under  $f'$  will move to  $E_{free}$  under  $f^*$  by getting  $\gamma_e^* = \gamma$  and having  $f_e^* = o_e$ . Note that an

<sup>2</sup>this doesn't destroy property *ii*), as the flow through  $e$  would be  $o_e$

edge  $e \in E_{free}$  with  $f'_e \geq o_e$  and  $\gamma_e^* = \gamma$  cannot get in  $E_{lock}$  under any  $f^*$  that satisfies (a).

If inequality (b) is tight then we first let  $\gamma_{e_m} = 0$  and add it to  $\Gamma^*$  to make a  $\gamma$ -modification  $\Gamma$ . We then let  $f_{e_m} = o_{e_m} - x_m$  and  $f_e = f_e^*$  for all other edges. The pair  $(f, \Gamma)$  satisfies the Lemma. If inequality (b) is not tight but  $x_m = o_{e_m}$ <sup>3</sup>, then we first let  $\gamma_{e_m} = 0$  and add it to  $\Gamma^*$  to make a  $\gamma$ -modification  $\Gamma$  and then we let  $f_{e_m} = 0$  and  $f_e = f_e^*$ . The pair  $(f, \Gamma)$  satisfies the Lemma.<sup>4</sup>

If inequality (b) is not tight and  $x_m < o_{e_m}$  then set  $f' = f^*$ ,  $o_{e_m} = o_{e_m} - x_m$ ,  $r' = r' + x_m$  and  $\Gamma' = \Gamma^*$  and repeat the procedure.

To complete the proof, it suffices to show that, the above steps are finite and in the final step, inequality (b) holds with equality or  $e_m$  is empty of flow. To see this, first observe that at any step (that ended without (b) being tight and without  $e_m$  being empty of flow), because of (I), the number of edges that have either  $f'_e < o_e$  or ( $f'_e = o_e$  and  $\gamma'_e < \gamma$ ) drops down by at least one. In the worst case, this number will drop down to zero and thus in the next step either (b) will get tight or  $x_m = o_{e_m}$ , as then the rerouting may continue unrestricted.  $\square$

Next we give an upper bound of the  $PoA_\gamma$  of  $\gamma$ -modifiable instances with latency functions in class  $\mathcal{D}$ . The pair  $(f, \Gamma)$  of Lemma 14.2 is used in an analysis similar to [29]. The notable difference comes to the factor  $-\gamma(x - y)d(x)$  that arises in  $\sup_{d \in \mathcal{D}, x \geq y \geq 0} \frac{y(d(x) - d(y)) - \gamma(x - y)d(x)}{xd(x)}$  because of the ability to  $\gamma$ -modify the instances.

**Theorem 7.3.** For  $\gamma$ -modifiable parallel-links instances with cost functions in class  $\mathcal{D}$ , it is

$$PoA_\gamma(\mathcal{D}) \leq \rho_\gamma(\mathcal{D}) = \max \left\{ 1, \frac{1}{1 - \beta_\gamma(\mathcal{D})} \right\},$$

where  $\beta_\gamma(\mathcal{D}) = \sup_{d \in \mathcal{D}, x \geq y \geq 0} \frac{y(d(x) - d(y)) - \gamma(x - y)d(x)}{xd(x)}$

*Proof.* Let  $\mathcal{G} = (G, r)$  be a parallel links instance with cost functions in class  $\mathcal{D}$  and  $o$  be its optimal solution. For  $\mathcal{G}$ , Lemma 14.2 holds. Let  $f$  and  $\Gamma$  be the flow and the  $\gamma$ -modification given by Lemma 14.2. By definition, it is  $PoA_\gamma(\mathcal{G}) \leq PoA(\mathcal{G}^\Gamma)$ . We will bound  $PoA(\mathcal{G}^\Gamma)$ .

Let  $E_{max}^f$  be the set of edges that have  $f_e < o_e$ ,  $E_{min}^f$  be the set of edges that have  $f_e > o_e$  and  $E_{int}^f$  be the set of used edges with  $f_e = o_e$ . Clearly  $E = E_{max}^f \cup E_{min}^f \cup E_{int}^f$

It is  $PoA(\mathcal{G}^\Gamma) = \frac{\sum_{e \in E} f_e d_e(f_e)}{\sum_{e \in E} o_e d_e(o_e)}$ . Using variational inequality and the  $\gamma_e$ 's of  $\Gamma$  (for which we have a Nash flow) we get

<sup>3</sup>which implies  $d_{e_m}(0) > L(G_m, (1 + \Gamma^*)d, r)$

<sup>4</sup>induction hypothesis for the instance  $(G_m, r)$  could also be applied

$$\begin{aligned}
& \sum_{e \in E_{\max}^f} f_e d_e(f_e) + \sum_{e \in E_{\min}^f} f_e(1 + \gamma) d_e(f_e) + \sum_{e \in E_{\text{int}}^f} f_e(1 + \gamma_e) d_e(f_e) \\
& \leq \sum_{e \in E_{\max}^f} o_e d_e(f_e) + \sum_{e \in E_{\min}^f} o_e(1 + \gamma) d_e(f_e) + \sum_{e \in E_{\text{int}}^f} o_e(1 + \gamma_e) d_e(f_e) \\
& \quad \Downarrow \\
& \sum_{e \in E} f_e d_e(f_e) \leq \sum_{e \in E} o_e d_e(f_e) - \sum_{e \in E_{\min}^f} \gamma(f_e - o_e) d_e(f_e) - \sum_{e \in E_{\text{int}}^f} \gamma_e(f_e - o_e) d_e(f_e) \\
& \leq \sum_{e \in E} o_e(d_e(f_e) - d_e(o_e)) + \sum_{e \in E} o_e d_e(o_e) - \sum_{e \in E_{\min}^f} \gamma(f_e - o_e) d_e(f_e) \\
& \leq \sum_{e \in E} o_e d_e(o_e) + \sum_{e \in E_{\min}^f} (o_e(d_e(f_e) - d_e(o_e)) - \gamma(f_e - o_e) d_e(f_e))
\end{aligned}$$

Setting  $\beta_\gamma(\mathcal{D}) = \sup_{d \in \mathcal{D}, x \geq y \geq 0} \frac{y(d(x) - d(y)) - \gamma(x - y)d(x)}{xd(x)}$  we get

$$\begin{aligned}
\sum_{e \in E} f_e d_e(f_e) & \leq \sum_{e \in E} o_e d_e(o_e) + \sum_{e \in E_{\min}^f} \frac{(o_e(d_e(f_e) - d_e(o_e)) - \gamma(f_e - o_e) d_e(f_e)) f_e d_e(f_e)}{f_e d_e(f_e)} \\
& \leq \sum_{e \in E} o_e d_e(o_e) + \beta_\gamma(\mathcal{D}) \sum_{e \in E_{\min}^f} f_e d_e(f_e) \\
& \quad \Downarrow \\
& \frac{\sum_{e \in E} f_e d_e(f_e)}{\sum_{e \in E} o_e d_e(o_e)} \leq \frac{1}{1 - \beta_\gamma(\mathcal{D})} = \rho_\gamma(\mathcal{D})
\end{aligned}$$

Putting everything together, we have

$$PoA_\gamma(\mathcal{G}) \leq PoA(\mathcal{G}^\Gamma) = \frac{\sum_{e \in E} f_e d_e(f_e)}{\sum_{e \in E} o_e d_e(o_e)} \leq \rho_\gamma(\mathcal{D})$$

Thus, for the class of games with latency functions in class  $\mathcal{D}$  it is

$$PoA_\gamma(\mathcal{D}) \leq \rho_\gamma(\mathcal{D})$$

□

Next we give upper bounds for specific classes of  $\gamma$ -modifiable instances.

**Corollary 7.4.** For  $\gamma$ -modifiable instances with degree  $d$  polynomial latency functions

$$PoA = 1, \text{ if } \gamma \geq d \text{ and } PoA \leq \frac{1}{1 - d\left(\frac{\gamma+1}{d+1}\right)^{\frac{d+1}{d}} + \gamma}, \text{ if } \gamma < d$$

*Proof.* Let  $\mathcal{G}$  be a  $\gamma$ -modifiable instance with degree  $d$  polynomial latency functions and let  $o$  be the optimal solution of  $\mathcal{G}$ .

By (e.g.) [77]  $o$  is the Nash flow of a game with the same underlying network and traffic rate  $r$  but cost functions changed from  $d_e(x)$  to  $(xd_e(x))'$ . Thus, for polynomials of degree  $d$ ,  $o$  coincides with the Nash flow of a game with the same underlying network and rate  $r$  but cost functions changed from  $\sum_{i=0}^d a_i x^i$  to  $\sum_{i=0}^d (i+1)a_i x^i$ .

If  $\gamma \geq d$ , it is  $\sum_{i=0}^d (i+1)a_i x^i \leq (\gamma+1) \sum_{i=0}^d a_i x^i$  and thus there exist  $\gamma_e$ 's so as for any edge  $e$   $\sum_{i=0}^d (i+1)a_i o_e^i \leq (1+\gamma_e) \sum_{i=0}^d a_i o_e^i$ , which implies that  $o$  is  $d$ -enforceable.

For  $\gamma < d$  we bound  $\beta_\gamma(\mathcal{D})$ . It is  $\frac{y(d(x)-d(y))-\gamma(x-y)d(x)}{xd(x)} = \frac{y}{x}\left(1 + \gamma - \frac{d(y)}{d(x)}\right) - \gamma$ . For a polynomial of degree  $d$ ,  $d(x) = \sum_{i=0}^d a_i x^i$ , and  $y \leq x$  it is  $\frac{d(y)}{d(x)} \geq \frac{y^d}{x^d}$  as  $y^{d-i} \leq x^{d-i} \Rightarrow \sum a_i y^i x^d \geq \sum a_i x^i y^d$ . Thus  $\frac{y}{x}\left(1 + \gamma - \frac{d(y)}{d(x)}\right) - \gamma \leq \frac{y}{x}\left(1 + \gamma - \frac{y^d}{x^d}\right) - \gamma$ . This quantity is maximized for  $y$  satisfying  $(y^{d+1})' = (1+\gamma)x^d$  which gives  $y = \sqrt[d]{\frac{\gamma+1}{d+1}}x$ ,  $\beta_\gamma(\mathcal{D}) = d\left(\frac{\gamma+1}{d+1}\right)^{\frac{d+1}{d}} - \gamma$  and  $\rho_\gamma(\mathcal{D}) = \frac{1}{1 - d\left(\frac{\gamma+1}{d+1}\right)^{\frac{d+1}{d}} + \gamma}$   $\square$

By setting  $d = 1$  to Corollary 14.4 we bound the price of anarchy for affine latencies.

**Corollary 7.5.** For  $\gamma$ -modifiable instances with affine latencies

$$PoA = 1, \text{ if } \gamma \geq 1 \text{ and } PoA \leq \frac{1}{1 - \frac{(1-\gamma)^2}{4}}, \text{ if } \gamma < 1$$

**Remark 7.6.** Relating  $\rho(\mathcal{D})$  (from [29]) with  $\rho_\gamma(\mathcal{D})$  for the class  $\mathcal{D}$  of affine latencies we get that  $\rho_\gamma(\mathcal{D}) = \frac{1}{1 + \frac{\gamma(2-\gamma)}{3}}\rho(\mathcal{D})$  which drops down quickly as  $\gamma$  grows from 0 to 1.

Next we show that these bounds are essentially tight.

**Theorem 7.7.** For any class of latency functions  $\mathcal{D}$ , and any  $\epsilon > 0$  there is an instance  $\mathcal{G}$  with latency functions in  $\mathcal{D}$  with  $PoA_\gamma(\mathcal{G}) \geq \rho_\gamma(\mathcal{D}) - \epsilon$

*Proof.* Let  $\epsilon > 0$  and consider a  $\gamma$ -modifiable instance  $\mathcal{G}$  of two parallel links,  $e_1$  and  $e_2$ , flow rate  $r$  and cost functions: an arbitrary cost function

$d_1(x) = d_\epsilon(x)$  (to be fixed later) in class  $\mathcal{D}$  for link  $e_1$  and the constant function  $l_2(x) = (1 + \gamma)d_\epsilon(r)$  for link  $e_2$ .

Under any  $\gamma$ -modification  $\Gamma = (\gamma_1, \gamma_2)$ , at Nash flow  $f$  of  $\mathcal{G}^\Gamma$ , all the flow goes through link  $e_1$  and thus  $SC^f = rd_\epsilon(r)$ . At optimal flow  $o$ , let  $o_1$  be the flow that goes through link  $e_1$ . It is  $SC^o = (r - o_1)(\gamma + 1)d_\epsilon(r) + o_1d_\epsilon(o_1)$  and

$$PoA = \frac{rd_\epsilon(r)}{(r - o_1)(\gamma + 1)d_\epsilon(r) + o_1d_\epsilon(o_1)} = \frac{1}{1 - \frac{o_1(d_\epsilon(r) - d_\epsilon(o_1)) - \gamma(r - o_1)d_\epsilon(r)}{rd_\epsilon(r)}}$$

Flow  $o$  is optimal and thus  $o_1 \in [0, r]$  is exactly the value that minimizes social cost and eventually maximizes  $\frac{rd_\epsilon(r)}{(r - o_1)(\gamma + 1)d_\epsilon(r) + o_1d_\epsilon(o_1)}$  and so maximizes

$$\frac{o_1(d_\epsilon(r) - d_\epsilon(o_1)) - \gamma(r - o_1)d_\epsilon(r)}{rd_\epsilon(r)} \quad (7.1)$$

Recall that  $\beta_\gamma(\mathcal{D}) = \sup_{d \in \mathcal{D}, x \geq y \geq 0} \frac{y(d(x) - d(y)) - \gamma(x - y)d(x)}{xd(x)}$  and let  $d_\epsilon(x)$  be a cost function such that  $\sup_{x \geq y \geq 0} \frac{y(d_\epsilon(x) - d_\epsilon(y)) - \gamma(x - y)d_\epsilon(x)}{xd_\epsilon(x)} \geq \beta_\gamma(\mathcal{D}) - \frac{\epsilon(1 - \beta_\gamma(\mathcal{D}))^2}{1 - \epsilon(1 - \beta_\gamma(\mathcal{D}))}$ . Because  $o_1$  maximizes (14.1), it is  $\frac{o_1(d_\epsilon(r) - d_\epsilon(o_1)) - \gamma(r - o_1)d_\epsilon(r)}{rd_\epsilon(r)} \geq \beta_\gamma(\mathcal{D}) - \frac{\epsilon(1 - \beta_\gamma(\mathcal{D}))^2}{1 - \epsilon(1 - \beta_\gamma(\mathcal{D}))}$  and thus

$$PoA \geq \frac{1}{1 - \beta_\gamma(\mathcal{D}) + \frac{\epsilon(1 - \beta_\gamma(\mathcal{D}))^2}{1 - \epsilon(1 - \beta_\gamma(\mathcal{D}))}} = \rho_\gamma(\mathcal{D}) - \epsilon$$

□

Based on Lemma 14.2, we present an algorithmic approach that given a  $\gamma$ -modifiable instance  $\mathcal{G}$  computes a  $\gamma$ -modification  $\Gamma$  such that the Nash flow  $f$  of  $\mathcal{G}^\Gamma$  is such that  $\frac{SC^f}{SC^o} \leq \rho(\mathcal{D})$ , with  $\mathcal{D}$  being the class of latency functions of  $\mathcal{G}$ .

**Lemma 7.8.** Let  $o$  be the optimal flow of a parallel links instance  $\mathcal{G}$ . A flow  $f$  and a  $\gamma$ -modification  $\Gamma$  of  $\mathcal{G}$  with the properties of Lemma 14.2 can be computed in time  $\frac{|E|(|E|+1)}{2} \text{Time}(\text{AlgPar})$ , where  $\text{Time}(\text{AlgPar})$  denotes the time complexity of an algorithm  $\text{AlgPar}$  that computes Nash flows in parallel links networks.

*Proof.* We first compute the optimal solution  $o$  of  $\mathcal{G}$  and delete all unused by  $o$  edges, so we assume that w.l.o.g. all edges of  $G$  are used by  $o$ . Then, we search efficiently in the space of flows for an  $f$  that can be combined with a  $\gamma$ -modification  $\Gamma$  of  $\mathcal{G}$  such that  $f$  and  $\Gamma$  satisfy Lemma 14.2. The key point we use from Lemma 14.2 (and prove later on) is that for the pair  $(f, \Gamma)$  of the proposition, the edges that have  $f_e < o_e$  are the most costly used edges under  $o$  while the edges that have  $f_e > o_e$  are the less costly edges under  $o$ .



In detail, for a combination  $(k, l) : k + l \leq |E|$  find sets  $E_{max} : |E_{max}| = k$  and  $E_{min} : |E_{min}| = l$  such that  $E_{max}$  contains the  $k$  most costly edges of  $G$  under  $o$  and  $E_{min}$  contains the  $l$  less costly edges of  $G$  under  $o$ <sup>5</sup>. Let  $\mathcal{G}'$  be the  $\gamma$ -modifiable instance that has only the edges  $E_{max}$  and  $E_{min}$ , traffic rate  $r' = \sum_{e \in E_{max} \cup E_{min}} (o_e)$  and the latency functions of edges in  $E_{min}$  changed from  $d_e(x)$  to  $(1 + \gamma)d_e(x)$ .

For all combinations of  $(k, l) : k + l \leq |E|$ , we compute the Nash flow  $f'$  of  $\mathcal{G}'$ . If  $f'$  is such that (1)  $\forall e \in E_{max} : f'_e \leq o_e$ , (2)  $\forall e \in E_{min} : f'_e \geq o_e$  and (3)  $\forall e \in E \setminus (E_{max} \cup E_{min}) : \frac{1}{1+\gamma}L(\mathcal{G}') \leq d_e(o_e) \leq L(\mathcal{G}')$  then we let for each edge  $e \in E \setminus (E_{max} \cup E_{min})$ ,  $\gamma_e = \frac{L(\mathcal{G}')}{d_e(o_e)} - 1$ . Clearly for any such  $e$  it is  $0 \leq \gamma_e \leq \gamma$ . By setting  $\gamma_e = \gamma$  for all edges in  $E_{min}$  and  $\gamma_e = 0$  for all edges in  $E_{max}$  we get a  $\gamma$ -modification  $\Gamma$  such that the Nash flow  $f$  of  $\mathcal{G}^\Gamma$  satisfies Lemma 14.2 and thus Theorem 14.3 applies.

It remains to show that there is a pair  $(k, l)$  such that (1), (2) and (3) hold. By Lemma 14.2, there is a feasible flow  $f$  and a  $\gamma$ -modification  $\Gamma$  of  $\mathcal{G}$  such that

i)  $f$  is the Nash flow in  $\mathcal{G}^\Gamma$ .

ii) for any edge  $e$ : if  $f_e < o_e$  then  $\gamma_e = 0$  and if  $f_e > o_e$  then  $\gamma_e = \gamma$ .

Let  $E_{max} = \{e \in E | f_e < o_e\}$ ,  $E_{min} = \{e \in E | f_e > o_e\}$  and  $E_{int} = \{e \in E | f_e = o_e\}$ . Because  $f$  is a Nash flow in  $\mathcal{G}^\Gamma$ , for any  $e_{max} \in E_{max}$ ,  $e_{min} \in E_{min}$ ,  $e_{int} \in E_{int}$  it is  $d_{e_{max}}(f_{e_{max}}) \geq (1 + \gamma_{e_{int}})d_{e_{int}}(f_{e_{int}}) \geq (1 + \gamma)d_{e_{min}}(f_{e_{min}})$ . This, combined to [for  $e \in E_{max}$  it is  $d_e(o_e) \geq d_e(f_e)$ , for  $e \in E_{int}$  it is  $d_e(o_e) = d_e(f_e)$  and for  $e \in E_{min}$  it is  $d_e(o_e) \leq d_e(f_e)$ ] implies that  $E_{max}$  contains the most costly edges under  $o$  and  $E_{min}$  contains the less costly edges under  $o$ . Thus for pair  $(|E_{max}|, |E_{min}|)$ , properties (1), (2) and (3) hold.

Clearly the above procedure needs at most  $\frac{|E|(|E|+1)}{2}$  (possible pairs of  $(k, l)$ ) computations of the Nash flow of  $\mathcal{G}'$  under the different flow rates that may arise. Thus the lemma follows.  $\square$

### 7.3 Σύνδεση με Παίγνια με Περισμμένους Φόρους

Bonifaci et al. in [17] studied routing games where along with each edge, an upper bound on the allowable toll on that edge is given. They provide a characterization for the flows that can be imposed by the restricted tolls and compute the optimal tolls when the optimal flow is inducible. We have drawn an iff condition (Theorem 14.1 for parallel links and a similar one for series parallel networks) that better suites our multiplicative approach and is also needed to follow the other results.

<sup>5</sup>so as  $E_{max} \cap E_{min} = \emptyset$

Also in [17], based on the previous characterization, they manage to compute the tolls that induce the smallest cost at equilibrium for parallel link networks. Their approach is essentially using a convex programming solver that solves several convex programs. One of these convex programs considers exactly the edges that is used by the best modification. This way though, no information about the nature of the solution is given.

Our approach intuitively applies Karush Kuhn Tucker conditions to the convex program that considers exactly the edges that is used by the best modification and tries to follow them. It does so, by restricting the  $(f_e, \gamma_e)$  pairs on the edges in a way similar to the restrictions provided by the Karush Kuhn Tucker conditions (Lemma 14.2).

This approach has two major benefits. The first of them is that it relates the complexity of finding a good (wrt PoA bounds)  $\gamma$ -modification to the complexity of finding Nash flows. The second one is that it allows to get a simpler mathematical expression as a bound for the PoA. This expression is both giving a better insight for the improvement that can be achieved via  $\gamma$ -modifications<sup>6</sup> and applies to cases with more general latency functions (for which a tight example is given) than the polynomial latency functions considered in [17]<sup>7</sup>.

As a last positive comment for our work<sup>8</sup>, we point out that by our approach, uncertainty is applied only to edges that intuitively have to get some uncertainty while by the approach of [17] more or less all edges get some uncertainty which is the minimum between their toll bound or their marginal toll. Their derived bounds rely to the fact that in worst case examples there are edges of constant cost that take no toll. Thus in our approach the total amount of uncertainty is kept lower while for cases “away” from the worst case examples our modifications ought to give better improvement results.

## 7.4 Αλλάζοντας τα Παίγνια σε πιο Γενικά Δίκτυα

In this section we show a way for generalizing the results of the parallel links case to the case of series parallel networks and to the case of parallel links with heterogeneous players and more general restrictions on the

<sup>6</sup>compare the PoA bound of  $\gamma$ -modifiable games with our approach, i.e.  $\frac{1}{1-\beta_\gamma(\mathcal{D})}$ , where  $\beta_\gamma(\mathcal{D}) = \sup_{d \in \mathcal{D}, x \geq y \geq 0} \frac{y(d(x)-d(y))-\gamma(x-y)d(x)}{xd(x)}$ , to the PoA bound of standard CGs (without tolls), i.e.  $\frac{1}{1-\beta(\mathcal{D})}$ , where  $\beta(\mathcal{D}) = \sup_{d \in \mathcal{D}, x \geq y \geq 0} \frac{y(d(x)-d(y))}{xd(x)}$ .

<sup>7</sup>for general latency functions the approach of [17] is not guaranteed to give better bounds than the ones without tolls.

<sup>8</sup>for series parallel networks.

uncertainty added to each edge.

### Σειριακά Παράλληλα Δίκτυα

The main goal is to get a  $\gamma$ -modification similar to the one of Lemma 14.2 which restricts the pairs  $(f_e, \gamma_e)$  to be such that if  $f_e > o_e$  then  $\gamma_e = \gamma$  and if  $f_e < o_e$  then  $\gamma_e = 0$ . Once such a Lemma is proved, the analysis of the PoA bound of Theorem 14.3 can be applied and a similar Theorem would hold.

To prove such a Lemma, we use induction on the decomposition of the series parallel network. The complicated part of the induction is the parallel composing one. Assuming that for each of the parallel composing networks the induction hypothesis of the lemma holds we start rerouting flow from one network to the other in a careful way so as the properties for the  $(f_e, \gamma_e)$  pairs do not break. The way the rerouting occurs is similar to the rerouting in the parallel links case, i.e. all the  $\gamma_e$ 's are locked and get unlocked only if  $f_e$  gets equal to  $o_e$  during the rerouting which itself reduces the largest fraction of used paths with common ends until it reaches  $\gamma + 1$ .

The constructive nature of this lemma will allow us also to get such a flow in time polynomially related to the time for computing a Nash flow, i.e. an analogue of Lemma 14.8 can be derived. The rerouting procedure will have to stop either to lock or unlock a  $\gamma_e$  of an edge  $e$  or to leave an edge empty of flow. Because each of these incidents may happen only once for each edge, we get that the rerouting will stop at most  $O(|E|)$  number of times. For the exact flow that gets rerouted each time, a binary search in the space of flows has to be made, that calls several times a Nash flow solver, which at the end returns a flow for which one of the above incidents happens.

### Δίκτυα Παράλληλων Ακμών με Ετερογενείς Παίκτες

The main goal is again to get a  $\gamma$ -modification similar to the one of Lemma 14.2. When players are heterogeneous then at equilibrium the more risk averse players get to higher expected cost edges. We assume that the edges are ordered according to their cost under optimal flow.

The new thing with the rerouting when trying to follow the proof of Lemma 14.2 is that it should stop also whenever a type of risk averse players entirely leaves an edge to get to the next one. If during the rerouting this happens, then the rerouting should continue up to that edge until this specific edge gets a cost equal to the cost of the next edge, where the cost is wrt the cost of the less risk averse users on this edge. That will allow the rerouting to continue to the next edges and the new player type to enter

the next edge.

To compute such a flow-modification pair, a more sophisticated approach than the homogeneous case is needed. We know that in such a flow-modification pair only some of the highest cost (under optimal flow) edges,  $E_h$ , will get no uncertainty added, only some of the lowest cost (under optimal flow) edges,  $E_l$  will get all the uncertainty they could and all other edges,  $E_i$ , will have  $f_e = o_e$ . For each combination of possible  $(E_h, E_i, E_l)$  triples, we do a binary search to see the amount of flow that will go through  $E_h$  (which will directly give the amount of flow that goes through  $E_l$ ) in order to have a (Nash flow,  $\gamma$ -modification) pair with the desired properties. For some triples we will have to stop the procedure as there may be no such pair for them, though, because of the previous lemma it ought to be a triple for which such a pair exists and which we eventually will find.

To derive a bound on the PoA we may follow a variational inequality approach, one for each risk aversion type. Then all these variational inequalities can be combined but with the risk averse factor on each edge being the lowest one on that edge. Thus in total a PoA bound (that is in fact tight) similar to Theorem 14.3 can be derived for the smallest risk averse factor among the players.

The above approach was allowing  $\gamma$ -modification on the edges. Another way to see  $\gamma$ -modifications is to allow  $\gamma_e$ 's on the edges so as  $\|(\gamma_e)_{e \in E}\|_\infty \leq \gamma$ . So to generalize the approach we may let  $\gamma_e$ 's to be such that  $\|(\gamma_e)_{e \in E}\|_p \leq \gamma$  for any chosen p-norm. We then can show that treating such a p-norm allowable modification as in a  $(\gamma/\sqrt[p]{|E|})$ -modifiable CG, we can derive asymptotically tight results on the improvement of the PoA.

**Part II**  
**English Version**



# Chapter 8

## Introduction

Congestion Games provide a natural model for non-cooperative resource allocation in large-scale communication networks and have been the subject of intensive research in Algorithmic Game Theory. In this chapter, we first give a small introduction to the “Congestion Games Space”, inside of which all the (leading, studied) different cases and generalizations of Congestion Games (CGs in short) lie. A literature overview follows right after with emphasis given to the bibliography part that strongly relates to our work.

### 8.1 Congestion Games

In a *Congestion Game* [73], a set of identical non-cooperative players, controlling an equal amount of load, compete over a finite set of resources. All players using a particular resource, experience a cost (or latency) given by a non-negative and non-decreasing function of the resource’s load (or congestion). Each player selects her strategy, a subset of resources, selfishly trying to minimize her *individual cost*.

The focus on CGs is on the so-called *network* CGs where there is an underlying network given and each player’s strategy space is formed by the paths from her origin node to her destination node in the network. The edges of the network, that come together with a cost function, are the resources of the network CG. The following hold for general CGs although most of the work in the literature and also our work deals with network CGs.

### Cases

Many different cases of CGs arise if one considers different assumptions on the players' strategy spaces, on the players' types or on the players' strategies' costs. More specific, players may all have the same strategy space, symmetric games case, or different strategy spaces, asymmetric games case. Also, players might be finite and route a significant amount (a unit) of load through the network, and thus may affect the resources' cost, atomic games case, or be infinite and route a negligible (infinitesimally small) amount of flow through the network and thus cannot unilaterally affect the resources' costs, non atomic games. Moreover each player's costs might be the sum of the resources' costs on player's strategy, additive costs games, or the maximum resource's cost among the resources' costs in player's strategy, bottleneck costs. Figure 8.1 schematically presents the above.

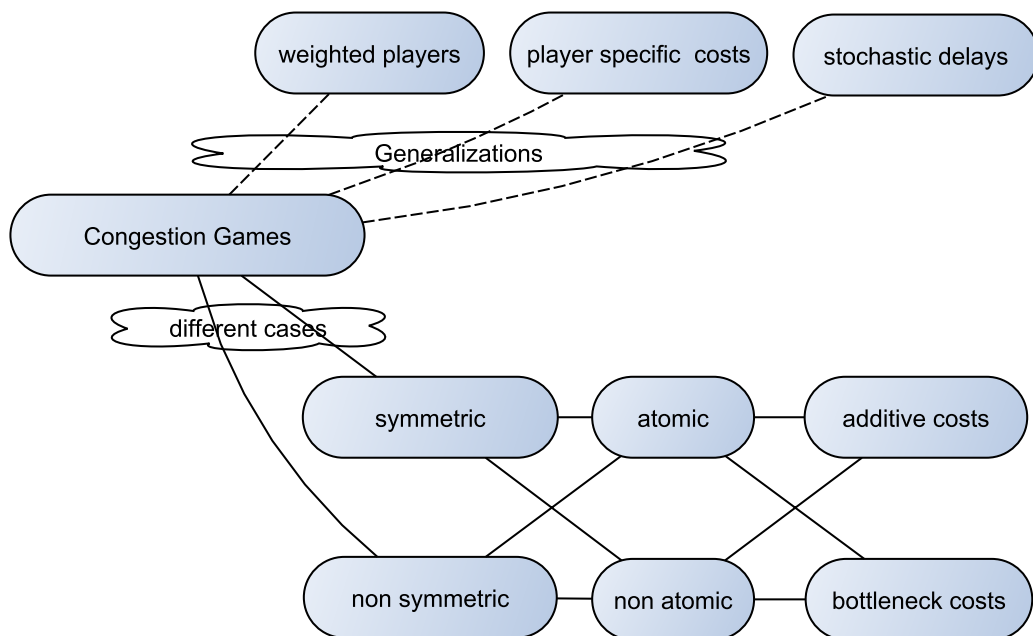

**Figure 8.1:** Network Congestion Games (small) map. The upper part captures the leading generalizations of CGs. The lower part captures the different cases arising by considering assumptions on the players' strategy spaces, on the players' types and on the players' strategies' costs.



### Generalizations

CGs can be naturally generalized to games where players have different demands (for the atomic case), called weights, i.e. route different amounts of flow through the network (in network congestion games). These games are called *weighted* CGs. Another natural generalization assumes that resources' cost functions are player dependent, i.e. each player perceives a (possibly) different cost function on each resource. These are CGs *with player-specific cost functions*. Deciding under uncertainty has drawn much attention in CGs in the very last few years. Models of congestion games with stochastic delays and risk averse players extend CGs in order to capture real life situations and predict human behavior. Figure 8.1 helps.

### Performance

In a Congestion Game, a natural solution concept is that of a *pure Nash equilibrium* (PNE), a configuration where no player can decrease her cost by unilaterally changing her strategy. At the other end, the network manager cares about the public benefit and aims to minimize the *total cost* incurred by all players. Since a Nash equilibrium does not need to optimize the total cost, one seeks to quantify the inefficiency due to selfish behavior. The *Price of Anarchy* was introduced in [57] and has become a widely accepted measure of the performance degradation due to the players' selfish behavior. The (pure) Price of Anarchy is the worst-case ratio of the total cost of a (pure) Nash equilibrium to the optimal total cost. Many recent contributions have provided strong upper and lower bounds on the Price of Anarchy (PoA) for several classes of CGs. The forthcoming literature overview includes also these results.

The prevailing questions in CGs of any of the different cases described above (or even for subcases of them), have to do with the existence and computation of equilibria, with the convergence time of better or best response dynamics (i.e. the steps to reach an equilibrium starting from an initial configuration and letting players do a better or best response, one at a time), with deriving bounds on the PoA and with exploring ways to improve network's performance (tolls, stackelberg strategies, exploiting braess paradox, see section 8.3). Citations (together with some details) of published work dealing with these questions and the main results of the literature part that relates the most to our work paper are given in the remaining of the chapter.

## 8.2 Bibliography Overview

Next we put together bibliography sources dealing with the prevailing questions in the different variants of CGs. The biggest portion of this literature concerns additive costs games although there is a non negligible portion concerning bottleneck costs games. For results on improving network's performance continue to section 8.3 and for games with stochastic delays see section 8.4

### Additive Costs

For results on the existence of Nash equilibrium one should see [73] where the method of potential function is used to prove the existence of a pure Nash Equilibrium (PNE) in CGs and [66] where the equivalence of CGs with potential games is proved. On section 10.3 we open the first pages of these works.

For results on the complexity of finding PNE see e.g. [33], where the class PLS was proved to fully capture the difficulty of finding pure Nash equilibrium in general, symmetric or asymmetric CGs, [30], where hardness results for the existence of PNE in weighted games is given and [3] where hardness results for the existence and computation of PNE in player-specific CGs is given.

For results on the PoA in non atomic games see e.g. [74], where PoA bounds are given that actually depend only to the class of the cost functions of the resources and are independent of the network topology and [28], where a simpler proof of the previous result was given that also can be applied in more general settings. Also, one could see [64], where it is shown that topological properties might help the network in performing well.

For results on the PoA in atomic games see e.g. [8], where PoA bounds are given for cases where the costs are linear functions or polynomials of degree  $d$ , [23], where also bounds (slightly stronger for some cases) for cases where the costs are linear functions or polynomials of degree  $d$  are given but also a more general method for bounding PoA is introduced and [4], where exact bounds are given using similar techniques to [23] that also apply to weighted CGs.

For results on the convergence times to PNE see e.g. [32], where bounds on convergence time for singleton CGs (strategies are singletons) for both weighted and unweighted CGs, [39], where, among others, the convergence time to PNE is investigated for the case of network CGs with linearly independent paths. For results on the convergence times to approximate

Nash equilibrium (where players costs are approximately equal) see e.g. [81], where strong hardness results on convergence times of best response dynamics are drawn, [21], where positive results for the convergence times in symmetric games are given, [9], where the above work is extended to the asymmetric case when a special property that helps to bypass the in-approximability of [81] holds and [1] where properties of strategies' spaces are investigated so as to have fast convergence times.

For games with player-specific cost functions see e.g. [63], where the study of player-specific cost functions was initiated in singleton CGs, [2], where, among others, more general networks that guarantee PNE existence are investigated, [61], where the differences in the player-specific cost functions that players perceive are only constants, [2], where the networks found in [61] are proved to be optimal topologically and a polynomial algorithm of finding the guaranteed to exist pure PNE is given and [46] where properties of the class of cost functions are investigated for both the cases of weighted or unweighted CGs in order to have PNE.

For games with weighted players see e.g. [44], where the model of weighted CGs is introduced and results on the existence of equilibrium and potential functions are presented, [69] for experimental results on computing PNE in the model of [44], [2] where, as in player-specific games, more general networks that guarantee PNE existence are investigated, [14], where the PoA (whenever a PNE exists) is related with the class of allowable cost functions and worst case results are proved in close relation with the ones in unweighted games, [65], where topological properties are shown to strongly relate with the existence of a PNE and [50], where an exact characterization of the set of cost functions that guarantee a PNE existence is given.

### **Bottleneck Costs**

For results in non atomic games see e.g. [27], where the theoretical study of bottleneck games were initiated and [62], where the uniqueness and optimality of PNE is investigated in parallel-links, series parallel and general networks. For results concerning Braess's paradox see section 8.3.

For results in atomic games see e.g. [11], where the study for atomic games was initiated, the non uniqueness of PNE was proved, convergence's rates were studied and bounds on PoA were achieved, [18], where results on the PoA related to the network structure are presented while existence of a social optimal PNE is also proved, [31], where complete characterizations of the networks that have optimal PoA is given (series-parallel networks for the pre-described version of bottleneck games and extended parallel net-

works for another version defined therein) and [19], where results related to the existence, complexity, and price of anarchy of PNE for several network games (symmetric and asymmetric, with identical or weighted players) are given.

### 8.3 Reducing the Price of Anarchy

The degradation of the network due to players' selfish behavior has drawn much attention in the past. In the literature, there are three prevailing ways to tackle this degradation.

**Taxing the edges:** changing the cost functions of the players by adding taxes on the edges (resources) of the network.

**Stackelberg strategies:** changing the fraction of selfish players by assuming that some players are willing to cooperate for social welfare.

**Excluding the Braess's paradox:** changing the network topology by making some edges (resources) unavailable.

#### 8.3.1 Taxing the Edges of the Network

A CG with taxes is a typical CG with an extra tax vector that gives the taxes for the edges of the network. The players' cost are modified so as to consider also the cost due to taxes on the edges they choose. Players may have different sensitivities in taxes and this is captured by a constant coming along with each player.

Taxes increase the cost of the players without affecting the social cost function and thus can be used without charge by the network manager. Ideally, one would like, by taxing the edges, to have the Nash Equilibria of the new game be an optimum flow in the original game. These taxes are called *optimal taxes*.

#### Non Atomic Case

In non atomic games the problem of designing optimal tax vectors has been studied extensively. A classic result going all the way back to Pigou [70] states that marginal cost taxes induce the optimal traffic pattern for homogeneous players [13]. A significant volume of recent work on optimal taxes for non atomic CGs considers the more intriguing and realistic case of *heterogeneous* players, which may have different valuations of time (latency)

in terms of money (taxes). Yang and Huang [86] established the existence of optimal taxes for non atomic asymmetric network CGs with heterogeneous players. Subsequently, their result was rediscovered by Fleischer, Jain, and Mahdian [36], and Karakostas and Kolliopoulos [54]. Previously the single-source special case had been investigated by Cole, Dodis, and Roughgarden [26].

The existence of optimal taxes for non atomic CGs with heterogeneous players follows from Linear Programming duality ([36, 54]), and thus an optimal tax vector can be computed efficiently by solving a linear program.

For non atomic games, under mild assumptions on the latency functions the edge flow at equilibrium is unique. Hence the taxes of [13, 26, 36, 54, 86] induce the optimal solution as the unique edge flow of the equilibria of the game with taxes.

### Atomic Case

Atomic CGs, even with splittable traffic (players can use more than one paths to route their flow), may admit many different Nash equilibria, possibly with different edge flows. Therefore, when considering atomic games, one has to distinguish between

- *weakly-optimal* tax vectors, for which at least one Nash equilibrium of the game with taxes minimizes the total latency, and
- *strongly-optimal* tax vectors, for which all Nash equilibria of the game with taxes minimize the total latency.

For atomic CGs with splittable traffic and heterogeneous players, Swamy [82] proved that weakly-optimal tax vectors exist and can be computed efficiently. In fact they can be computed by solving a convex program similar to the ones in [36] and [54].

As for atomic CGs with unsplittable traffic, the existence and efficient computation of optimal taxes has been studied in the setting of homogeneous players.

Caragiannis, Kaklamanis, and Kanellopoulos [20] considered atomic games with linear latency functions and homogeneous players, and investigated how much taxes can improve the price of anarchy. On the negative side, they established that if the players either do not share the same source and sink or have different traffic demands, then strongly-optimal taxes may not exist. On the positive side, they presented an efficient construction of strongly-optimal taxes for parallel-link games with linear latencies and unit-demand players.

Subsequently, Fotakis and Spirakis [45] proved that weakly-optimal taxes exist and can be computed efficiently for atomic symmetric network CGs, and that such taxes are strongly-optimal if the network is series-parallel.

For the case of heterogeneous players, results follow from the technique used in the non atomic case. Fotakis, Karakostas and Kolliopoulos in [43], using a linear program like one in [54], prove the existence of weakly optimal tolls for games with heterogeneous players with the *same source node*. Also, in [43], it is given a counter example that shows that players' heterogeneity precludes the existence of strongly-optimal taxes even on the simplest topology of parallel-link networks.

### **Restrictions on the Allowable Taxes**

More recently, Höfer et al. ([51]) studied non atomic CGs with taxes where only a subset of the resources is allowed to get taxes and, on the negative side they provided an NP-hardness result for finding optimal taxes for general networks with linear latency functions and two commodities while on the positive side, for single-commodity networks with parallel links and linear latency function, they provided a polynomial time algorithm for finding optimal taxes.

Following this work, Bonifaci et al. ([17]) studied the (non atomic) case where along with each edge, an upper bound on the allowable tax on that edge is given. They provide a characterization for the flows that can be imposed by the restricted taxes and compute the optimal taxes when the optimal flow is inducible. Also based on this characterization, they manage to compute the taxes that induce the smallest cost at equilibrium for parallel links networks. They also derive tight (even for parallel link networks) bounds on the efficiency of restricted tolls for multi-commodity networks and polynomial latency functions.

Jelinek et al. in [53] generalized the above model to atomic CGs and to CGs with taxes with heterogeneous players. For non atomic and heterogeneous players, they prove that the problem is NP-hard even for single-commodity networks and affine latency functions. On the positive side they give an algorithm for optimally taxing subnetworks with affine latency functions. For weighted atomic players, the problem is NP-hard already for parallel-arc networks and linear latency functions, even if players are homogeneous. Focusing on parallel links games, for unweighted atomic and homogeneous players, they develop an algorithm to compute optimal restricted tolls and for unweighted atomic and heterogeneous players, they derive an algorithm for optimally taxing subnetworks.

### 8.3.2 Stackelberg Strategies

In Stackelberg routing, the network manager, as a central authority, coordinates a fixed fraction  $a$  of the players and assigns them to appropriately selected strategies trying to minimize the performance degradation due to the selfish behavior of the remaining players.

A *Stackelberg strategy* is an algorithm that determines the strategies of the coordinated players. The problem that arises for the coordinating authority is, given a fraction  $a$  under her influence, to find the *best stackelberg strategy* so as to minimize the inefficiency caused by the selfishness of the other players. Note that for  $a = 0$  we get a classical congestion game.

The first case that has been thoroughly studied is the case of parallel link networks (networks with two nodes and parallel edges joining them) with linear latency functions.

Roughgarden in [75] proved that it is NP-hard to compute the optimal Stackelberg strategy via a technical reduction from the  $\frac{1}{3}\frac{2}{3}$ PARTITION problem. He also presented three simple strategies with provable performance guarantees. The first of the three, computes the optimum of the game with  $an$  players ( $n$  the number players in the original game) and finds the edges for these players. In the original game the algorithm assigns the coordinated players on the same edges they would stay in the optimum he computed. The second one, namely the *SCALE* algorithm, after computing the optimal solution  $x^*$  assign to each link  $e$ ,  $ax_e^*$  players. The third one, the Largest Latency First (*LLF*) algorithm, computes the optimal solution and assigns the coordinated players to the most costly edges (links), fulling them in decreasing order.

Swamy in [82] obtained the first results for non atomic routing in graphs more general than parallel-link graphs, and strengthen existing results for parallel-link graphs. In series-parallel graphs (sepa) he showed that Stackelberg routing reduces the PoA to a constant (depending on the fraction of flow controlled). The algorithm that does the work is the *LLF*. For general graphs, he obtained latency-class specific bounds on the PoA with Stackelberg routing, which give a continuous trade-off between the fraction of flow controlled and the PoA. The bounds come from analyzing the performance of the *SCALE* and the *LLF* algorithm. A part of this proof followed the same technique as the one in Correa et. al ([28]). In parallel-link graphs, he showed that Stackelberg routing reduces the PoA to a convex combination of the worst case PoA when  $a = 0$  and the optimal performance when  $a = 1$ . The convex combination factors are  $1 - a$  and  $a$  respectively.

Karakostas and Kolliopoulos in [54] analyzed *LLF* and *SCALE* algorithms, for general topology networks, multicommodity players, and linear

latency functions. They showed a PoA bound for *SCALE* which decreases from worst case PoA to 1 as  $a$  increases from 0 to 1, and depends only on  $a$ , generalizing this way the known bound for the parallel links network which nevertheless has one single commodity. An interesting fact is that a good lower bound for *SCALE* is the instance of Braess's Paradox which we'll see later on (section 8.3.3). A weaker bound for *LLF* and some extensions to general latency functions were also shown.

Bonifaci et al. in [16], constructed a family of singlecommodity (non atomic) instances such that every Stackelberg strategy induces a price of anarchy that grows linearly with the size of the network. This bound does not depend on the fraction  $a$  of the coordinated players. Moreover, they prove upper bounds on the price of anarchy of the largest-latency-first (*LLF*) strategy that only depend on the size of the network. Besides other implications, this rules out the possibility to construct constant-size networks to prove an unbounded price of anarchy. They also analyze the effectiveness of *SCALE*, proving bounds for a general class of latency functions that includes polynomial latency functions as a special case. Their analysis is based on an approach that is simple yet powerful enough to obtain (almost) tight bounds for *SCALE* in general networks improving this way the bounds of Swamy ([82]) presented above

Fotakis in [38] investigated the effectiveness of Stackelberg strategies for atomic CGs with unsplittable demands. Two orthogonal cases were considered: i) linear CGs with arbitrary strategies and ii) CGs on parallel links with arbitrary non-negative and non-decreasing latency functions. For the second case, the same bound as in non atomic games (Swamy [82]) was proved. For the case of linear CGs with arbitrary strategies, algorithms *SCALE* (changed appropriately for the atomic case) and *LLF* were analyzed and upper and lower bounds were derived

In [38], a new stackelberg strategy was proposed. An interesting case arises when the number of players is large and the number of coordinated players is considerably larger than the number of resources, even if  $a$  is small. To take advantage of this possibility, a simple Stackelberg strategy was introduced, called *COVER*. Assuming that the ratio of the number of coordinated players to the number of resources is no less than a positive integer  $\hat{n}$ , *COVER* assigns to every resource either at least  $\hat{n}$  or as many coordinated players as the resource has in the optimal configuration. The PoA of *COVER* tends to the PoA of the corresponding non atomic linear CG as  $\hat{n}$  grows. The idea proposed was to combine algorithms *LLF* and *SCALE* with *COVER* to take advantage of the above fact. On the negative side, in [38], it is presented a lower bound that holds not only for *SCALE*, but



also for any randomized Stackelberg strategy that assigns the coordinated players to their optimal strategies.

### 8.3.3 Tackling the Braess's Paradox

Braess's Paradox is a counter intuitive fact stating that when removing (adding) edges from (to) a network, its performance may increase (decrease). Figures 8.2 and 8.3 are examples for additive and bottleneck costs games respectively.

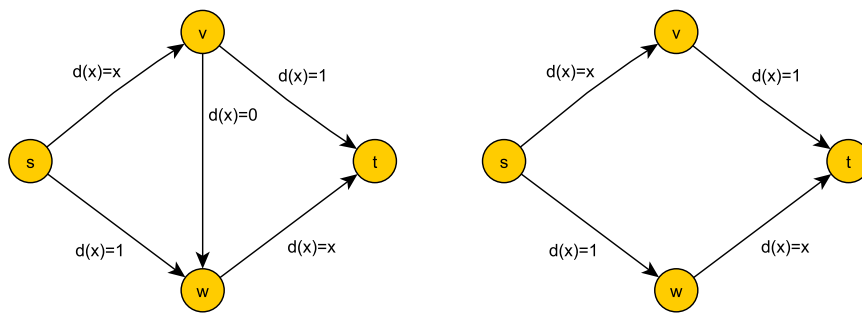

**Figure 8.2:** A unit of flow is to be routed from  $s$  to  $t$ . (a). The optimal (additive costs) flow routes  $1/2$  unit of traffic on the upper path  $(s, v, t)$  and  $1/2$  unit on the lower path  $(s, w, t)$ , and achieves a total latency of  $3/2$ . In the Nash flow, all traffic goes through the path  $(s, v, w, t)$ . The players' latency is 2, and the PoA is  $4/3$ . (b). Without the edge  $(v, w)$ , the Nash flow coincides with the optimal flow.

The idea is to improve the network performance at equilibrium by exploiting the essence of the Braess's paradox, that is to remove some network edges in order to decrease the latency of the Nash flow (the induced flow on Nash equilibrium). Thus, given a CG, we seek for the *best subnetwork*, i.e. the subnetwork minimizing the players' latency at (worst) equilibrium.

Valiant and Roughgarden [84], in order to theoretically support that Braess's paradox is not an artifact of theory, proved that (under additive costs) it occurs with high probability on random networks, and that for a natural distribution of linear latencies, edge removal may improve, with high probability, the equilibrium latency by a constant factor. Across the same lines, Chung and Young in [24] adopting the random graphs model of Erdős-Rényi showed that Braess's paradox occurs when  $np \geq c \log(n)$  for some  $c > 1$  ( $n, p$  the random graphs' parameters). See also [47] for a slight generalization by the same authors.

### Additive Costs Games

Unfortunately, Roughgarden [78] proved that it is *NP*-hard not only to find the best subnetwork, but also to compute any meaningful approximation to the equilibrium latency on the best subnetwork. In particular, he showed that even for linear latencies, it is *NP*-hard to distinguish between *paradox-free* instances, where edge removal cannot improve the equilibrium latency, and *paradox-ridden* instances, where the total latency of the Nash flow on the best subnetwork is equal to the optimal total latency (i.e. edge removal can decrease the PoA to 1). This implies that the only known algorithm for approximating the equilibrium latency on the best subnetwork is the trivial one, which does not remove any edges!

Fotakis, Kaporis and Spirakis in ([42]) examined the "Braess's paradox problems" for some practically interesting settings and managed to provide a polynomial-time algorithm that decides if a network is paradox-ridden, when latencies are linear and strictly increasing, a polynomial-time algorithm for the problem of finding the best subnetwork, which outperforms any known approximation algorithm for the case of strictly increasing linear latencies and an algorithm for finding a subnetwork that is almost optimal wrt equilibrium latency which is *subexponential* when the number of paths is polynomial and each path is of polylogarithmic length.

They also prove that the problem of deciding if a network with arbitrary linear latencies is paradox-ridden reduces to the problem of generating all optimal basic feasible solutions of a Linear Program that describes the optimal traffic allocations to the edges with constant latency. As an extension of exploiting the paradox, it was provided a polynomial-time method that turns the optimal flow into a Nash flow by deleting the edges not used by the optimal flow, and performing minimal modifications to the latencies of the remaining ones.

Since Roughgarden's negative results, trying to detect Braess's Paradox wasn't incentive. Considering the results of [42] though, the problem of detecting the "bad", Braess's paradox's edges, if any, gets a lot more interesting.

### Bottleneck Costs Games

Every bottleneck routing game is known to admit a Nash flow that is optimal for the network, in the sense that it minimizes the maximum latency on any used edge, a.k.a. the bottleneck cost of the network (see e.g. [11, Corollary 2]). On the other hand, bottleneck routing games usually admit many different Nash flows, some with a bottleneck cost quite far from the

optimum. Hence, there has been a considerable interest in quantifying the performance degradation due to the players' non-cooperative and selfish behavior in (several variants of) bottleneck routing games.

Simple examples (see, e.g., figure 15.2 or [27, Figure 2]) demonstrate that the PoA of bottleneck routing games with linear latency functions can be as large as  $\Omega(n)$ , where  $n$  is the number of vertices of the network.

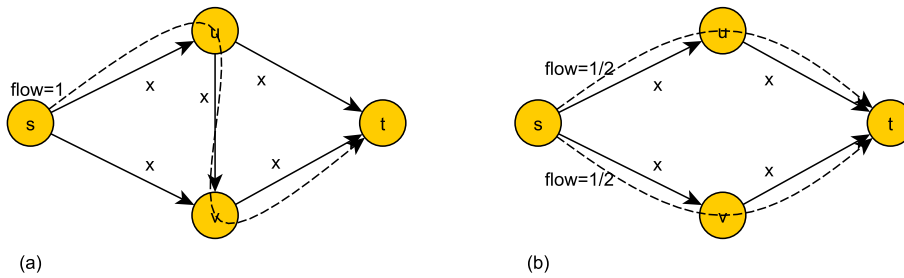

**Figure 8.3:** An example of Braess's paradox for bottleneck routing games. We consider a routing instance with identity latency functions and a unit of traffic to be routed from  $s$  to  $t$ . The worst Nash flow, in (a), routes all flow through the path  $(s, u, v, t)$ , and has a bottleneck cost of 1. On the other hand, the optimal flow routes  $1/2$  unit through the path  $(s, u, t)$  and  $1/2$  unit through the path  $(s, v, t)$ , and has a bottleneck cost of  $1/2$ . Hence,  $\text{PoA} = 2$ . In the subnetwork (b), obtained by removing the edge  $(u, v)$ , we have a unique Nash flow that coincides with the optimal flow, and thus the PoA becomes 1.

For atomic splittable bottleneck routing games, where the population of players is finite, and each player controls a non-negligible amount of traffic which can be split among different paths, Banner and Orda [11] observed that the PoA can be unbounded, even for very simple networks, if the players have different origins and destinations and the latency functions are exponential. On the other hand, Banner and Orda proved that if the players use paths that, as a secondary objective, minimize the number of bottleneck edges, then all Nash flows are optimal. For a variant of non atomic bottleneck routing games, where the social cost is the average (instead of the maximum) bottleneck cost of the players, Cole, Dodis, and Roughgarden [27] proved that the PoA is  $4/3$ , if the latency functions are affine and a subclass of Nash flows, called *subpath-optimal Nash flows*, is only considered. Subsequently, Mazalov et al. [62] studied the inefficiency of the best Nash flow under this notion of social cost.

For atomic unsplittable bottleneck routing games, where each player routes a unit of traffic through a single  $s - t$  path, Banner and Orda [11] proved that for polynomial latency functions of degree  $d$ , the PoA is  $O(m^d)$ , where  $m$  is the number of edges of the network. On the other hand, Epstein

et al. ([31]) proved that for series-parallel networks with arbitrary latency functions, all Nash flows are optimal. Subsequently, Busch and Magdon-Ismail [18] proved that the PoA of atomic unsplittable bottleneck routing games with identity latency functions can be bounded in terms of natural topological properties of the network. In particular, they proved that the PoA of such games is bounded from above by  $O(l + \log n)$ , where  $l$  is the length of the longest  $s - t$  path, and by  $O(k^2 + \log^2 n)$ , where  $k$  is length of the longest cycle.

Once again, in this setting, one may distinguish two extreme classes of instances: *paradox-free* instances, where edge removal cannot improve the bottleneck cost of the worst Nash flow, and *paradox-ridden* instances, where the bottleneck cost of the worst Nash flow in the best subnetwork is equal to the optimal bottleneck cost of the original network (see also [78, 42]).

The approximability of selective network design, a generalization of network design where we cannot remove certain edges, was considered by Hou and Zhang [52]. For atomic unsplittable bottleneck routing games with a different traffic rate and a different origin and destination for each player, they proved that if the latency functions are polynomials of degree  $d$ , it is NP-hard to approximate selective network design within a factor of  $O(m^{d-\varepsilon})$ , for any constant  $\varepsilon > 0$ . Moreover, for atomic  $k$ -splittable bottleneck routing games with multiple origin-destination pairs, they proved that selective network design is NP-hard to approximate within any constant factor.

However, a careful look at the reduction of [52] reveals that their strong inapproximability results crucially depend on both (i) that we can only remove certain edges from the network, so that the subnetwork actually causing a high PoA cannot be destroyed, and (ii) that the players have different origins and destinations (and also are atomic and have different traffic rates). As for the importance of (ii), in a different setting, where the players' individual cost is the sum of edge latencies on their path and the social cost is the bottleneck cost of the network, it is known that Braess's paradox can be dramatically more severe for instances with multiple origin-destination pairs than for instances with a single origin-destination pair. More precisely, Lin et al. [59] proved that if the players have a common origin and destination, the removal of at most  $k$  edges from the network cannot improve the equilibrium bottleneck cost by a factor greater than  $k + 1$ . On the other hand, Lin et al. [58] presented an instance with two origin-destination pairs where the removal of a single edge improves the equilibrium bottleneck cost by a factor of  $2^{\Omega(n)}$ . Therefore, both at the technical and at the conceptual level, the inapproximability results of [52] do not really shed light on the approximability of the (simple, non-selective)

network design problem in the simplest, and most interesting, setting of non atomic bottleneck routing games with a common origin-destination pair for all players.

## 8.4 Stochastic Congestion Games

Most research work on CGs essentially ignores the stochastic nature of edge delays, a feature of most practical applications, and assumes that the players select their strategies based on precise knowledge of the edge latencies, which are considered to be deterministic. On the contrary, in real life transportation or telecommunication networks, the players cannot accurately predict the actual edge delays. This happens not only because the players cannot know the exact congestion of every edge, but also due to (a priori unknown) external events (e.g., some construction work, a minor accident, a link failure) that may affect the edge latencies and introduce uncertainty. It is therefore natural to assume that the players decide on their strategies based only on estimations of their actual delay, and most important, that they are fully aware of the uncertainty and of the potential inaccuracy of their estimations. So, to secure themselves from the event of an increased delay, whenever this may have a considerable influence, the players select their paths taking uncertainty into account (e.g., people either take a safe route or plan for a larger-than-usual delay when they head to an important meeting).

Such considerations give rise to CGs with stochastic delays and risk-averse players, where instead of the path that minimizes her predicted (or expected) delay, each player selects a path that guarantees her a reasonably low actual delay with a reasonably high confidence. To take uncertainty into account, the actual delay of each player can be modeled by a random variable. Then, a common assumption is that the players seek to minimize either a convex combination of the expectation and the variance of their delay, or a player-specific quantile of the delay distribution (see also [83, 34] about the cost functions of risk-averse players, and [72] about possible ways of risk quantification in optimization under uncertainty).

Following the research direction above, Ordóñez and Stier-Moses [68] considered non atomic CGs, where the population of players is infinite and each player controls a negligible amount of load, and suggested that each path should be penalized by an additive term that increases with the risk-aversion of the players and with the maximum deviation from the expected delay of the path (however, this term does not depend on the actual load of the edges). For each path, the additive term can be chosen either as a

$\delta$ -fraction of (resp. a  $\delta$ -quantile of a random variable depending on) the maximum deviation from the expected delay of the path, or simply, as the sum of the  $\delta$ -fractions of the maximum deviation from the expected delay of each edge in the path, where  $\delta$  quantifies the risk-aversion of the players. Under some general assumptions, [68] proves that an equilibrium exists and is essentially unique in all the cases above.

Subsequently, Nikolova and Stier-Moses [67] suggested a model of stochastic selfish routing with risk-averse players, where each player selects a path that minimizes the expected delay plus  $\delta$  times the standard deviation of the delay, where  $\delta$  quantifies the risk-aversion of the players. They considered non atomic and atomic CGs, mostly with homogeneous players, that share the same risk attitude, and distinguished between the case where the standard deviation of a path's delay is *exogenous*, i.e., it does not depend on the load of the edges in the path, and the case where the standard deviation is *endogenous*, i.e., it is a function of the load. Nikolova and Stier-Moses [67] proved that in the exogenous case, which is similar to the model of [68], (non atomic and atomic) stochastic routing games essentially retain the nice properties of standard CGs: they admit a potential function and, in the non atomic setting, a unique equilibrium, and the inefficiency of equilibria can be bounded as for standard CGs. In the endogenous case, they proved that non atomic stochastic routing games admit an equilibrium, which is not necessarily unique, but may not admit a cardinal potential. Moreover, atomic stochastic routing games may not admit a PNE even in simple extension-parallel networks with 2 players and linear delays.

Following this research agenda, a better understanding of the properties of (atomic) CGs with stochastic delays and risk-averse players seems meaningful while cases with different risk-aversions for the players have not been studied at all.

Actually, there is a significant volume of work on theoretical and practical aspects of transportation networks with uncertain delays (see e.g., the discussion and the references in [67]). However, that line of research focuses on the non atomic setting and adopts specific notions of individual cost and viewpoints. Motivated from applications where the players have only partial knowledge of the number of players participating in the game, Ashlagi, Monderer, and Tennenholtz [7] considered CGs on parallel links with stochastic players. However, the players' individual cost in their model is the expected delay of the link chosen, and thus the players are risk-neutral. They studied mixed Nash equilibria, and proved that a generalization of the fully mixed equilibrium remains a mixed equilibrium if the players are stochastic.

# Chapter 9

## Contribution

Congestion Games constitute one of the most extensively studied fields of Algorithmic Game Theory. Nevertheless, as expected, there are still open problems in this area.

Our focus was twofold, yet finally connected. In one direction we dealt with problems related to detecting and excluding the Braess's Paradox, both in additive costs and bottleneck costs games, which lie in the family of problems related to reducing the Price of Anarchy of CGs.

In the other direction we addressed with the problem of generalizing CGs in such a way that uncertainty on the delays is taken under consideration, focusing basically on modeling the source of uncertainty on the resources. Apart from the drawn results for this model, surprisingly, this modeling shed light to a new way for improving the Price of Anarchy of a network, i.e. abuse the players' risk averse behavior and improve the network's performance by adding extra uncertainty as "noise" in its resources. By considering this, the directions of our work get an immediate relation.

Next we outline our contribution in each of the problems we investigated, while in the following sections we get into more detail for each of them.

- Braess Paradox in (the different versions of) bottleneck routing games was not fully understood and we managed to clear the field for the basic version of them (subsection 9.1 and chapter 11).
- Random networks (considered thus far in the literature) with high probability suffer from the Braess's Paradox when costs are additive. We managed to prove essentially that the way to prove the above can be cleverly yet carefully used to efficiently exploit the paradox in those networks (subsection 9.2 and chapter 12).

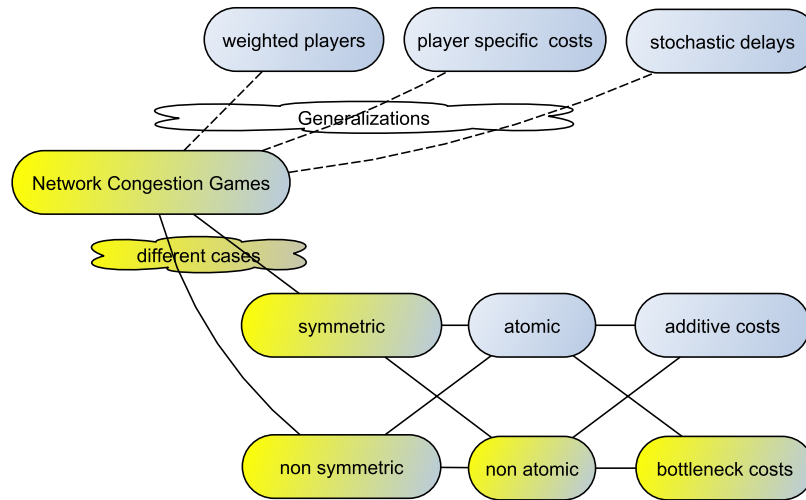

**Figure 9.1:** The main results (hardness results) of our work apply to both symmetric and asymmetric non atomic bottleneck costs games.

- Stochastic CGs and risk aversion has drawn much attention in the very recent years. By the work in chapter 13 (contribution in subsection 9.3), we move one step forward on understanding these classes of games.
- In certain settings, stochastic delays can actually improve the network performance at equilibrium (see e.g. [71]). In chapter 14 (contribution in 9.4), we show how we can abuse the risk aversion of the players and improve the network's performance.

## 9.1 Braess's Paradox in Bottleneck Costs Games

We investigate the approximability of the network design problem for the simplest, and seemingly easier to approximate, variant of non-atomic bottleneck routing games (with a single origin-destination pair). Our main result is that network design is hard to approximate within reasonable factors, and holds even for the special case of strictly increasing linear latencies. To the best of our knowledge, this is the first work that investigates the impact of Braess's paradox and the approximability of the network design problem for the basic variant of bottleneck routing games. For the original work see [41]. Figure 9.1 captures the model on which the results of this work hold.



In Section 11.2, we use techniques similar to those in [31, 27], and show that bottleneck routing games do not suffer from Braess's paradox either if the network is series-parallel, or if we consider only subpath-optimal Nash flows (definition in section 11.1).

On the negative side, we employ, in Section 11.3, a reduction from the 2-Directed Disjoint Paths problem, and show that for linear bottleneck routing games, it is NP-hard to recognize paradox-ridden instances (Lemma 11.1). In fact, the reduction shows that it is NP-hard to distinguish between paradox-ridden instances and paradox-free instances, even if their PoA is equal to  $4/3$ , and thus, it is NP-hard to approximate the network design problem within a factor less than  $4/3$ .

In Section 11.4, we apply essentially the same reduction, but in a recursive way, and obtain a much stronger inapproximability result. In particular, we assume the existence of a  $\gamma$ -gap instance, which establishes that network design is inapproximable within a factor less than  $\gamma$ , and show that the construction of Lemma 11.1, but with some edges replaced by copies of the gap instance, amplifies the inapproximability threshold by a factor of  $4/3$ , while it increases the size of the network by roughly a factor of 8 (Lemma 11.4). Therefore, starting from the  $4/3$ -gap instance of Lemma 11.1, and recursively applying this construction a logarithmic number of times, we show that it is NP-hard to approximate the network design problem for linear bottleneck routing games within a factor of  $O(n^{0.121-\varepsilon})$ , for any constant  $\varepsilon > 0$ . An interesting technical point is that we manage to show this inapproximability result, even though we do not know how to efficiently compute the worst equilibrium bottleneck cost of a given subnetwork. Hence, our reduction uses a certain subnetwork structure to identify good approximations to the best subnetwork. To the best of our knowledge, this is the first time that a similar recursive construction is used to amplify the inapproximability threshold of the network design problem, and of any other optimization problem related to selfish routing.

In Section 11.5, we consider latency functions that satisfy a Lipschitz condition, and present an algorithm for finding a subnetwork that is almost optimal w.r.t. the bottleneck cost of its worst Nash flow, when the worst Nash flow in the best subnetwork routes a non-negligible amount of flow on all used edges. The algorithm is based on Althöfer's Sparsification Lemma [5], and is motivated by its recent application to network design for additive routing games [42]. For any constant  $\varepsilon > 0$ , the algorithm computes a subnetwork and an  $\varepsilon/2$ -Nash flow whose bottleneck cost is within an additive term of  $O(\varepsilon)$  from the worst equilibrium bottleneck cost in the best subnetwork. The running time is roughly  $|\mathcal{P}|^{\text{poly}(\log m)/\varepsilon^2}$ , and is quasipolynomial, when the number  $|\mathcal{P}|$  of paths is quasipolynomial.

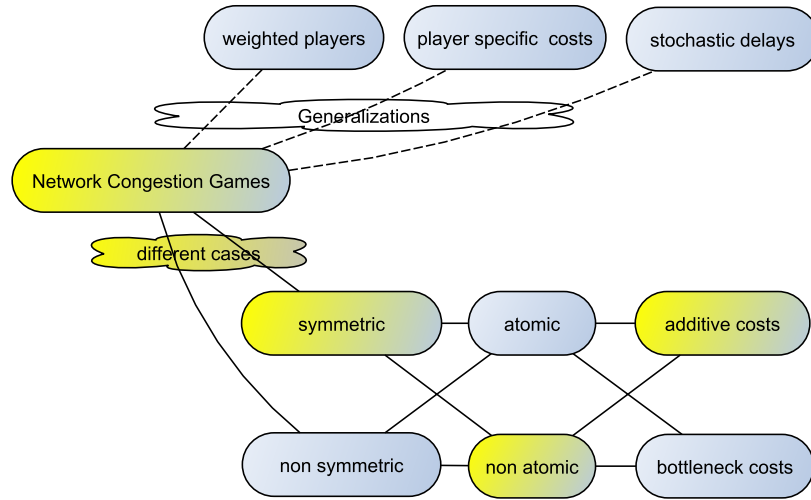

**Figure 9.2:** The case where the random networks under study lay

## 9.2 Braess's Paradox in Additive Costs Games

Departing from [24, 25, 84], that proved that random Erdős-Rényi  $\mathcal{G}_{n,p}$  graphs are prone to the paradox, we adopt a purely algorithmic approach. We focus on the class of so-called *good* selfish routing instances, namely instances with the properties used by [24, 84] to demonstrate the occurrence of Braess's paradox in random networks with high probability. In fact, one can easily verify that the random instances of [24, 84] are good with high probability. Rather surprisingly, we prove that, in many interesting cases, we can efficiently approximate the best subnetwork and its equilibrium latency.

What may be even more surprising is that our approximation algorithm is based on the expansion property of good instances, namely the very same property used by [24, 84] to establish the prevalence of the paradox in good instances! To the best of our knowledge, our results are the first of theoretical nature which indicate that Braess's paradox can be efficiently eliminated in a large class of practically interesting instances. For the original work see [40]. Figure 9.2 captures the model considered in this work.

Technically, we present essentially an approximation scheme; given a good instance and any constant  $\varepsilon > 0$ , we compute a flow  $g$  that is an  $\varepsilon$ -Nash flow for the subnetwork consisting of the edges used by it, and has a latency of  $L(g) \leq (1 + \varepsilon)L^* + \varepsilon$ , where  $L^*$  is the equilibrium latency of the best subnetwork (Theorem 12.1). Flow  $g$  whp has these properties.

Our results hold for any network in the class of good networks. This, of course, includes  $\mathcal{G}_{n,p}$  with  $p$  above the connectivity threshold, but it might also include other types of random expanders. Our approximation scheme runs in polynomial time for the most interesting case that the network is relatively sparse and the traffic rate  $r$  is  $O(\text{poly}(\ln \ln n))$ , where  $n$  is the number of vertices. Specifically, the running time is polynomial if the good network has average degree  $O(\text{poly}(\ln n))$ , i.e., if  $pn = O(\text{poly}(\ln n))$ , for random  $\mathcal{G}_{n,p}$  networks, and quasipolynomial for average degrees up to  $o(n)$ . As for the traffic rate, most work on selfish routing and selfish network design problems assumes that  $r = 1$ , or at least that  $r$  does not increase with the network's size (see e.g., [77], and the references there in). So, we can approximate, in polynomial-time, the best subnetwork for a large class of instances that, with high probability, include exponentially many  $s - t$  paths and paths of length  $\Theta(n)$ . For such instances, a direct application of [42, Theorem 3] gives an exponential-time algorithm.

The main idea behind our approximation scheme, and our main technical contribution, is a polynomial-time approximation-preserving reduction of the best subnetwork problem for a good network  $G$  to a corresponding best subnetwork problem for a *0-latency simplified network*  $G_0$ , which is a layered network obtained from  $G$  if we keep only  $s$ ,  $t$  and their immediate neighbors, and connect all neighbors of  $s$  and  $t$  by direct edges of 0 latency. We first show that the equilibrium latency of the best subnetwork does not increase when we consider the 0-latency simplified network  $G_0$  (Lemma 12.2). Although this may sound reasonable, we highlight that decreasing edge latencies to 0 may trigger Braess's paradox (e.g., starting from the network in Fig. 12.1.a with  $d_{(v,w)}(x) = 1$ , and decreasing it to  $d_{(v,w)}(x) = 0$  is just another way of triggering the paradox). The importance of our *0-latency simplified network* is that it greatly simplifies the network design problem, since it allows us to focus on the loads of the  $s$ ,  $t$  incident edges. In sharp contrast, the corresponding subnetworks in [84, Fig. 3b], [25, Sect. 2.3 Fig. 2], implicitly exhibit the paradox: they apply Chernoff's bounds to show that appropriate parts of these subnetworks whp have large cardinalities, implying that even more flow  $r$  can be routed through these subnetworks without increasing the selfish latency of the original network. The paradox implicitly follows by a non obvious yet intuitive fact [49, 59]: the selfish common latency is strictly increasing with the total flow  $r$ . Hence, we approximate the best subnetwork problem (Theorem 12.7) for our 0-latency simplified network by employing an approximate version of Caratheodory's Theorem (Theorem 12.6).

The final (and crucial) step of our approximation preserving reduction is to start with the flow-solution to the best subnetwork problem for the

0-latency simplified network, and extend it to a flow-solution to the best subnetwork problem for the original (good) instance. To this end, we show how to “simulate” 0-latency edges by low latency paths in the original good network. Intuitively, this works because due to the expansion properties and the random latencies of the good network  $G$ , the intermediate subnetwork of  $G$ , connecting the neighbors of  $s$  to the neighbors of  $t$ , essentially behaves as a complete bipartite network with 0-latency edges. This is also the key step in the approach of [24, 84], showing that Braess’s paradox occurs in good networks with high probability (see [24, Section 2]). Hence, one could say that to some extent, the reason that Braess’s paradox exists in good networks is the very same reason that the paradox can be efficiently resolved. Though conceptually simple, the full construction is technically involved and requires dealing with the amount of flow through the edges incident to  $s$  and  $t$  and their latencies. Our construction employs a careful grouping-and-matching argument, which works for good networks with high probability, see Lemmas 12.8 and 12.9.

We highlight that the reduction itself runs in polynomial time. The time consuming step is the one returning the (approximate) solution to the 0-latency simplified network. Since such networks have only polynomially many (and very short)  $s - t$  paths, they escape the hardness result of [78]. The approximability of the best subnetwork for 0-latency simplified networks is an intriguing open problem arising from our work that we discuss in section 15.1.

Our result shows that a problem, that is NP-hard to approximate, can be very closely approximated in random (and random-like) networks. This resembles e.g., the problem of finding a Hamiltonian path in Erdős-Rényi graphs, where again, existence and construction both work just above the connectivity threshold, see e.g., [15]. However, not all hard problems are easy when one assumes random inputs (e.g., consider factoring or the hidden clique problem, for both of which no such results are known in full depth).

### 9.3 Stochastic Congestion Games

We restrict our attention to atomic CGs, and introduce two variants of stochastic CGs, which are inspired by the main sources of uncertainty in delays of real transportation and telecommunication networks. We start from the observation that the variability of edge delays comes either from the variability of the traffic demand, and the subsequent variability of the edge loads, or from the variability of the edge performance level. Decou-

pling them, we introduce two variants of stochastic CGs, namely *Congestion Games with Stochastic Players* and *Congestion Games with Stochastic Edges*, each capturing one of the two sources of uncertainty above. For the original work see [6]. Figure 9.3 places our models on the congestion games map.

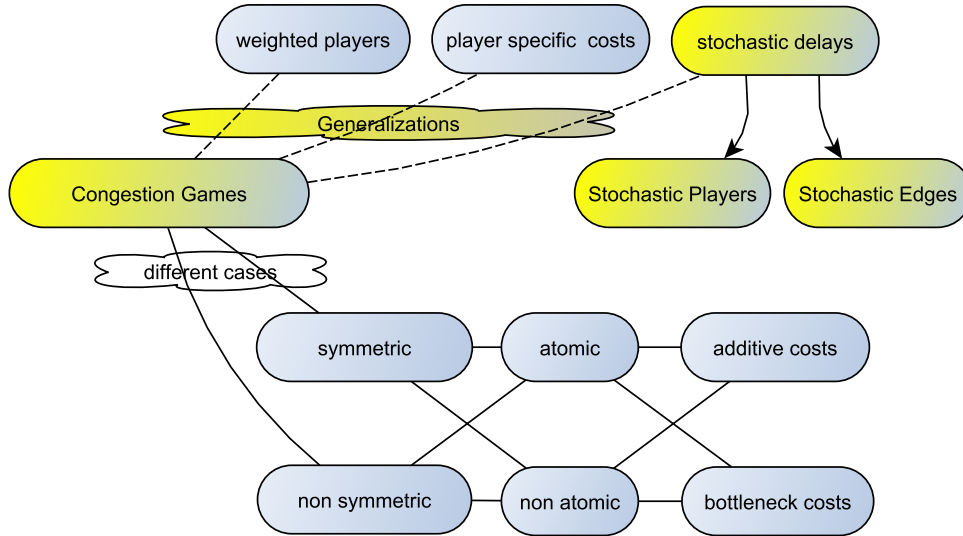

**Figure 9.3:** The introduced models and their positioning on the map.

CGs with Stochastic Players aim to model the variability of the traffic demand. Specifically, each player  $i$  participates in the game, by actually traversing her path, independently with probability  $p_i$ . As a result, the total network load, the edge loads, and the edge and the path latencies are all random variables. On the other hand, CGs with Stochastic Edges aim to model variability in the network operation. Now, each edge  $e$  may operate either at the “standard” mode, where its latency is given by a function  $f_e(x)$ , or at the “faulty” mode, where its latency is given by  $g_e(x)$ , where  $g_e(x) \geq f_e(x)$  for all  $x \geq 0$  (e.g., an edge operates at the “faulty” mode after a minor accident or a link failure). Each edge  $e$  switches to the “faulty” mode independently with a given probability  $p_e$ . Hence, the network load and the edge loads are now deterministic, but the edge and the path latencies are random variables. In both variants, we assume that the players adopt a risk-averse attitude to the stochastic delays. Specifically, each player  $i$  has a (possibly different) desired *confidence level*  $\delta_i$ , and her individual cost on a path  $q$  is the  $\delta_i$ -quantile (a.k.a. value-at-risk) of the delay distribution of  $q$ . In words, the individual cost of player  $i$  is the minimum delay she can achieve along  $q$  with probability at least  $\delta_i$ .

At the conceptual level, the model of CGs with Stochastic Players is similar to the model with endogenous standard deviations of [67]. In fact, using Chernoff bounds, we can show that for linear latency functions, if the expected edge loads are not too small, our  $\delta_i$ -quantile individual cost can be approximated by the individual cost used in [67]. However, we also consider stochastic demands, a direction suggested in [67, Sec. 7] to enrich the model, and players that are heterogeneous with respect to risk attitude. As for CGs with Stochastic Edges, the model is conceptually similar to the model with exogenous standard deviations of [67].

In the technical part, we restrict ourselves to the important special case of parallel-link networks with symmetric player strategies, and investigate how the properties of stochastic CGs depend on whether the players have the same participation probabilities and/or confidence levels or not. We first observe that such games admit a potential function and an efficiently computable PNE, if the players are homogeneous, namely if they have the same confidence level  $\delta$  and, in case of stochastic players, the same participation probability  $p$  (Theorems 13.1 and 13.8). We also show that if the players have different confidence levels (and the same participation probability, if they are stochastic), stochastic CGs belong to the class of player-specific congestion games [63], and thus admit a PNE computable in polynomial time (Corollaries 13.2 and 13.9). On the negative side, we prove that such games do not admit a potential function (Theorems 13.3 and 13.10). For CGs with Stochastic Players that have the same confidence level and different participation probabilities, we show that they admit a lexicographic potential (Theorem 13.5), and thus a PNE, and also that a PNE can be computed by a simple greedy best response algorithm (Theorem 13.4), where the players sequentially adopt their best response strategy in non-decreasing order of participation probabilities, given the strategies of the previous players in the order. As for the inefficiency of PNE, we focus on parallel-link networks with linear latency functions, and prove that the Price of Anarchy (PoA) is  $\Theta(n)$ , where  $n$  is the number of players, in the case of stochastic players (Theorems 14.3 and 13.7), and may be unbounded, in the case of stochastic edges (Theorem 13.11).

## 9.4 Improving Selfish Routing through Risk Aversion

Motivated by the results of [71], we consider (nonatomic) routing games with risk-averse players and investigate how one can exploit risk-aversion and modify the perceived cost of the players so that the PoA wrt. the total latency of the players is significantly improved. To the best of our knowl-

edge, this is the first time that risk-aversion is proposed and investigated as a remedy to the inefficiency of selfish routing.

Our starting point is that in some practical applications, we may carefully introduce exogenous variance in the edge delays so that the expected delay does not change, but the risk-averse cost of the players increases. For example, in a transportation network, this can be done by randomly increasing or decreasing the proportion of time allocated to the green traffic light for short time intervals or by opening or closing an auxiliary traffic lane. In a telecommunications network, we might randomly increase or decrease the link capacity allocated to a particular type of traffic or change its priority. Thus, we assume that for each edge  $e$ , we can increase (by a small multiplicative factor) the delay through  $e$  with some positive probability  $p_e$  and also decrease it with some positive probability  $q_e$ , where  $p_e$  and  $q_e$  are typically small, so that the expected latency through  $e$  remains  $d_e(x)$ . On the other hand, the variance in the delay introduced by such random changes increases the perceived cost of risk-averse players. Therefore, by carefully adjusting the perceived cost of the players, we can control the network congestion, in a way conceptually similar to that of refundable tolls, and improve the PoA through a delicate and easy to implement mechanism that exploits the risk-aversion of the players.

More specifically, we assume that all the players are homogenous wrt. their risk attitude and that random changes on the edge delays cause the perceived delays of the players to increase by a (typically small) multiplicative factor<sup>1</sup>. In fact, we assume that the perceived delay function of each edge  $e$  changes from  $d_e(x)$  to  $(1 + \gamma_e)d_e(x)$ , where  $\gamma_e > 0$  may depend on the edge, the type and the probability of random changes, the risk attitude of the players, the exact formula of the risk-averse individual cost and most importantly, the practical setting. Although we briefly discuss, in Section 14.1, how  $\gamma_e$  is determined and provide some examples, for simplicity and generality, we deliberately avoid getting into the details of how  $\gamma_e$ 's are precisely calculated. In contrast, we simply assume a given upper bound  $\gamma$  on the largest possible change in the delay functions and refer to the corresponding routing game as a  $\gamma$ -modifiable game (or instance), with the understanding in each particular application,  $\gamma$  can be determined by considering all the factors mentioned above. In this setting, a flow (and

<sup>1</sup>We mostly have in mind random (relatively small and short-term) changes that affect the link "capacity", e.g., opening or closing an auxiliary lane for a short time, increasing or decreasing the capacity of a telecommunication link by a certain factor, etc. As a result, we assume that the perceived cost of the players increases by a small multiplicative factor. This also distinguishes our technical approach and our results from the extensively studied case of additive refundable tolls (see e.g., [27, 35, 54, 55]).

in particular, the optimal flow, which minimizes the total actual latency of the players) is  $\gamma$ -enforceable (or simply, *enforceable*) if it is a Nash flow of the modified routing game with the perceived cost of each edge  $e$  equal to  $(1 + \gamma_e)d_e(x)$ , for some  $\gamma_e \in [0, \gamma]$ .

On the technical side, we observe that the maximum ratio of the optimal marginal-cost toll to the optimal edge latency gives an upper bound on the value of  $\gamma$  required to enforce the optimal flow (Proposition 16). This establishes the applicability of our approach and formalizes its connection to refundable tolls. However, in addition to the fact that we use multiplicative latency modifications, an important difference of our approach from (additive) refundable tolls is that we always assume an upper bound  $\gamma$  on the change of the perceived latencies, while optimal tolls do not assume any bounds and can become arbitrarily large, e.g., as large as the delay on the maximum delay  $s - t$  path used by the optimal flow (see e.g., [35, Theorem 4.1]).

Next, to demonstrate the efficiency of our approach, we focus on the simple and important special case of parallel-link networks (Section 14.2). We characterize the class of  $\gamma$ -modifiable routing games on parallel-links for which the optimal flow is enforceable (Theorem 14.1). Based on this characterization, we present a recursive procedure that given a  $\gamma$ -modifiable routing game and its optimal flow, computes a set of  $\gamma$ -bounded latency modifications and a  $\gamma$ -enforceable flow with PoA significantly less than the PoA of the original game (Lemma 14.2). Generalizing the variational inequality approach of [29], we prove that the PoA of the resulting flow is at most  $\max\{1, (1 - \beta_\gamma(\mathcal{D}))^{-1}\}$ , where  $\mathcal{D}$  is the class of the delay functions of the original routing game and

$$\beta_\gamma(\mathcal{D}) = \sup_{d \in \mathcal{D}, x \geq y \geq 0} \frac{y(d(x) - d(y)) - \gamma(x - y)d(x)}{xd(x)}$$

is a natural generalization of the quantity  $\beta(\mathcal{D})$  introduced in [29] (Theorem 14.3). For example, our analysis implies that for linear delays, the PoA of the  $\gamma$ -enforceable flow computed by our approach is at most  $\max\{1, (1 - (1 - \gamma)^2/4)^{-1}\}$  (Corollary 14.5), which is significantly less than  $4/3$  even for small values of  $\gamma$  (e.g., it is less than  $6/5$  for  $\gamma = 0.1$ ). We also show that our PoA analysis in terms of  $\gamma$  is tight wrt. all  $\gamma$ -enforceable flows (Theorem 14.7). Finally, we give a procedure that computes a set of  $\gamma$ -bounded latency modifications and a  $\gamma$ -enforceable flow with such PoA in time polynomially related to the time needed for computing Nash flows in parallel-links (Lemma 14.8). Therefore, given any  $\gamma$ -modifiable game on parallel-links, we can efficiently (for a wide class of latency functions)



compute a game with perceived delays changed by a factor of at most  $1 + \gamma$  such that the PoA is at most  $\max\{1, (1 - \beta_\gamma(\mathcal{D}))^{-1}\}$ .

In Section 14.3 we relate  $\gamma$ -modifiable CGs to routing games with restricted tolls ([17]). We point out the results of [17] that can be applied to  $\gamma$ -modifiable CGs while we support our constructive and more complicated approach for providing better insight for the problem of finding optimal  $\gamma$ -modifications and for the improvement on the PoA.

In section 14.4, we discuss how our approach can be extended to more general settings. First we give the intuition of how similar to the parallel links case results can be derived for the case of series parallel networks. Since we have completed the proofs that our results can be extended to the case of series parallel networks only recently, we chose not to include these results in this thesis. Instead, we explain the approach and provide sketches of the main ideas. Right after we discuss how we can derive similar results for the case of parallel links with heterogeneous players and more general restrictions on the uncertainty that is allowed to be added. Note here that this case is not solved by none of [51], [17] and [53], that deal with CGs with bounds on the allowable tolls.



# Chapter 10

## Congestion Games Preliminaries

In this chapter we state basic definitions needed in the following chapters. Model specific definitions and properties are given separately at the beginning of each chapter.

### 10.1 General Notation and Conventions

For a random variable  $X$ ,  $\mathbf{E}[X]$  denotes the **expectation** of  $X$  and  $\mathbf{Var}[X]$  denote the *variance* of  $X$ . For an event  $E$  in a sample space,  $\mathbf{Pr}[E]$  denotes the probability of  $E$  happening. We say that an event  $E$  occurs **with high probability**, if there is a constant  $a \geq 1$ , such that  $\mathbf{Pr}[E] \geq 1 - n^{-a}$ , where  $n$  usually denotes the number of vertices of the network  $G$  to which  $E$  refers. We implicitly use the union bound to account for the occurrence of more than one low probability events.

For any integer  $n \geq 1$ , we let  $[n] = \{1, \dots, n\}$

A latency function  $c_e(x)$  is **linear** if  $c_e(x) = a_e x$ , for some  $a_e > 0$ , and **affine** if  $c_e(x) = a_e x + b_e$ , for some  $a_e, b_e \geq 0$ . We say that a latency function  $c_e(x)$  satisfies the **Lipschitz condition** with constant  $\xi > 0$ , if for all  $x, y \in [0, r]$ ,  $|c_e(x) - c_e(y)| \leq \xi|x - y|$ .

### 10.2 Congestion Games Definitions

An **atomic Congestion Game** is a tuple  $\mathcal{G}(N, E, (S_i)_{i \in N}, (d_e)_{e \in E})$ , where  $N$  denotes the set of players,  $E$  denotes the set of resources,  $S_i \subseteq 2^E \setminus \{\emptyset\}$  denotes the strategy space of each player  $i$  and  $d_e : \mathbb{N} \mapsto \mathbb{R}_{\geq 0}$  is a non-negative and non-decreasing latency function associated with each resource  $e$ .

Network Congestion Games are CGs in which players have a source node,  $s_i$ , and a target node,  $t_i$ , on a directed graph (network) and the strategy space of each player  $i$  is consisted by the paths that connect  $s_i$  with  $t_i$ . The resources of the CG are exactly the edges of the network each of which comes together with a latency (cost) function.

An **atomic Network CG** is a tuple  $\mathcal{G}(G(V, E), (d_e)_{e \in E}, K, \{N\}_{i=1 \dots |K|})$ , where  $G = (V, E)$  denotes a directed network,  $K \subseteq V \times V$  is a set of  $s_i - t_i$  source target pairs,  $d_e : \mathbb{R}_{\geq 0} \mapsto \mathbb{R}_{\geq 0}$  is a non-negative and non-decreasing latency function associated with each edge  $e$  and  $N = (n_1, \dots, n_{|K|})$  is the vector of players, where  $n_i$  is the number of players that must move from source  $s_i$  to target  $t_i$ .

Non atomic network CGs are like atomic network CGs with infinite, infinitesimal players, i.e. the presence or the absence of a player on a resource does not affect the congestion on the resource. The infinite players that share the same  $s_i - t_i$  pair form an amount of flow that must be routed from  $s_i$  to  $t_i$ .

A **non atomic Network CG** is a tuple  $\mathcal{G}(G(V, E), (d_e)_{e \in E}, K, r)$ , where  $G = (V, E)$  denotes a directed network,  $K \subseteq V \times V$  is a set of  $s_i - t_i$  source target pairs,  $d_e : \mathbb{R}_{\geq 0} \mapsto \mathbb{R}_{\geq 0}$  is a non-negative and non-decreasing latency function associated with each edge  $e$  and  $r = (r_1, \dots, r_{|K|})$  is a vector of flows that must be routed, where  $r_i$  is the amount of flow that must be routed from source  $i$  to target  $i$ .

Network CGs are also referred as **Selfish Routing Games**. In a CG, if all players share the same strategy space then we have a *symmetric* CG. We deal with symmetric network CGs case where  $K$  contains a single  $s - t$  pair and thus, assuming that  $s$  and  $t$  are specified in  $G$ , we use the terminology  $\mathcal{G}(G(V, E), (d_e)_{e \in E}, n)$  for atomic network CGs, where  $n$  is the number of players that use the network, and  $\mathcal{G}(G(V, E), (d_e)_{e \in E}, r)$  for non atomic network CGs, where  $r$  is an amount of flow to be routed in the network. We let  $\mathcal{P}$  be the set of paths connecting  $s$  to  $t$ . We may also use  $\mathcal{G}(G(V, E), n)$  or  $\mathcal{G}(G(V, E), r)$  respectively if the set of latency functions under use is clear from the context or is assumed to be given within the network  $G$ .

**Subnetworks and Subinstances.** Given an instance  $\mathcal{G} = (G(V, E), (d_e)_{e \in E}, x)$ , any subgraph  $H(V, E')$ ,  $E' \subseteq E$ , obtained from  $G$  by edge deletions, is a *subnetwork* of  $G$ .  $H$  has the same origin  $s$  and destination  $t$  as  $G$ , and the edges of  $H$  have the same latency functions as in  $\mathcal{G}$ . Each instance  $\mathcal{H} = (H(V, E'), (d_e)_{e \in E'}, x)$ , where  $H(V, E')$  is a subnetwork of  $G(V, E)$ , is a *subinstance* of  $\mathcal{G}$ .

In atomic CGs, a **configuration** is a vector  $s = (s_1, \dots, s_n)$  consisting of

a strategy  $s_i \in S_i$  for each player  $i$ . We let  $s_e = \{|i : e \in s_i|\}$  denote the congestion induced on each resource  $e$  by  $s$ .

In non atomic network CGs, a (feasible) **flow**  $f$  is a non-negative vector indexed by  $\mathcal{P}$  so that  $\sum_{p \in \mathcal{P}} f_p = r$ . For a flow  $f$  and each edge  $e$ , we let  $f_e = \sum_{p: e \in p} f_p$  denote the amount of flow that  $f$  routes through  $e$ . An edge  $e$  is used by flow  $f$  if  $f_e > 0$ . A path  $p$  is used by flow  $f$  if all its edges are used, i.e.  $\min_{e \in p} \{f_e\} > 0$ . Somehow abusing notation, if  $p$  is used we may write  $f_p > 0$ .

**Additive Costs.** In additive costs atomic CGs, the cost of the strategy  $s_i$  of player  $i$  under configuration  $s$  is  $d_i(s) = \sum_{e \in s_i} d_e(s_e)$ . Similar, for additive costs non atomic network CGs, the cost of a path  $p$  under flow  $f$  is  $d_p(f) = \sum_{e \in p} d_e(s_e)$

**Bottleneck Costs.** In bottleneck costs atomic CGs, the cost of the strategy  $s_i$  of player  $i$  under configuration  $s$  is  $b_i(s) = \max_{e \in s_i} d_e(s_e)$ . Similar, for bottleneck costs non atomic network CGs, the cost of a path  $p$  under flow  $f$  is  $b_p(f) = \max_{e \in p} d_e(s_e)$ .

### 10.3 Equilibria

There are different ways to define an equilibrium. We are concerned in the case of *Pure Nash Equilibrium*. Informally, a configuration  $s$  or a flow  $f$  is a *Pure Nash equilibrium* if no player can improve her individual cost by unilaterally changing her strategy.

**Pure Nash Equilibrium - Nash flows.** For an atomic additive costs CG, a configuration  $s$  is said to be a Pure Nash Equilibrium (PNE) if  $d_i(s_i, s_{-i}) \leq d_i(s'_i, s_{-i}), \forall s'_i \in S_i$ , where  $d_i(k, s_{-i})$  denotes the cost of player  $i$  for the configuration where  $i$  plays strategy  $k$  and the rest of the players play according to configuration  $s$ . For a non atomic additive costs network CG,  $f$  is a Nash Equilibrium or a Nash flow if for all  $s-t$  paths  $p, p'$ , if  $f_p > 0$ , then  $d_p(f) \leq d_{p'}(f)$ .

Similar, for an atomic bottleneck costs CG, a configuration  $s$  is said to be a Pure Nash Equilibrium if  $b_i(s_i, s_{-i}) \leq b_i(s'_i, s_{-i}), \forall s'_i \in S_i$ , where  $b_i(k, s_{-i})$  denotes the cost of player  $i$  for the configuration where  $i$  plays strategy  $k$  and the rest of the players play according to configuration  $s$ . For a non atomic bottleneck costs network CG,  $f$  is a Nash Equilibrium or a Nash flow if for all  $s-t$  paths  $p, p'$ , if  $f_p > 0$ , then  $b_p(f) \leq b_{p'}(f)$ . A basic property of non atomic network CGs is that all players incur the same latency either under additive or under bottleneck costs.

**$\epsilon$ -Nash Equilibria (Flows).** The definition of a Nash Equilibrium can be

generalized to that of an “almost Nash” Equilibrium: For some constant  $\varepsilon > 0$ , a configuration or flow  $x$  is an  $\varepsilon$ -Nash Equilibrium if for all  $s - t$  paths  $p, p'$ , if  $x_p > 0$ ,  $d_p(x) \leq d_{p'}(x) + \varepsilon$ , for additive costs games and  $b_p(x) \leq b_{p'}(x) + \varepsilon$ , for bottleneck costs games.

**Potential Functions.** Games do not always possess PNE, though additive costs CGs always possess one. This can be proved via a potential function method. A function  $\Phi : S_1 \times \cdots \times S_n \mapsto \mathbb{R}_{\geq 0}$  is an *ordinal potential function* for a CG if  $d_i(s_{-i}, s'_i) - d_i(s) < 0 \Leftrightarrow \Phi(s_{-i}, s'_i) - \Phi(s) < 0$

Intuitively an ordinal potential is a function that follows the sign of change of any player's cost when she changes unilaterally. The admittance of the above type of potential is a necessary and sufficient condition for a game to have the Finite Improvement Property, i.e. every best response sequence is finite. So if letting the players, one at a time, to change their strategy to their best response then, at the end, we get a configuration that is a PNE.

A more strong kind of potential is the one encountered so far in CGs where a function tracks not only the sign but also the amount of the change. A function  $\Phi : S_1 \times \cdots \times S_n \mapsto \mathbb{R}_{\geq 0}$  is an *exact potential* for a CG if  $\Phi(s_{-i}, s'_i) - \Phi(s) = d_i(s_{-i}, s'_i) - d_i(s)$

Games that admit an exact potential are called *Potential Games*. It can be proved that additive costs CGs are isomorphic to Potential games. One direction is easy: CGs (atomic or non atomic with additive costs) always admit an exact potential:

**atomic case**

$$\Phi(s) = \sum_{e \in E} \sum_{i=1}^{s_e} d_e(i)$$

**non atomic case**

$$\Phi(s) = \sum_{e \in E} \int_0^{s_e} d_e(x) dx$$

For CGs with bottleneck costs, best response dynamics can also be used to prove the existence of (optimal) equilibrium, e.g. [11, Corollary 2], although, directly, the optimal solution (with respect to the social cost function defined in the next section) is a Nash equilibrium.

## 10.4 Price of Anarchy and Price of Stability

Players' strategies choices cause an overall charge on the resources of the game that can be seen as an overall cost charging the network manager or

the players' "society". This is quantified via a *Social Cost Function*.

A **Social Cost Function**, for atomic games, is a function  $SC(s) : S_1 \times \dots \times S_n \rightarrow \mathbb{R}_{\geq 0}$ . The most popular Social Cost Function used in additive costs CGs is the sum of the players' costs (or, somehow equivalently, the average of the players' costs), i.e.  $SC(s) = \sum_i d_i(s_i)$ . For bottleneck costs games, the most used social cost function is  $SC(s) = \max_i b_i(s_i) = \max_{e: s_e > 0} d_e(s_e)$ . Similar, for non atomic network CGs it is  $SC(f) : \text{Space of Flows} \rightarrow \mathbb{R}_{\geq 0}$  and for additive costs CGs,  $SC(f) = \sum_p f_p d_p(f_p)$  while for bottleneck costs CGs,  $SC(f) = \max_{p: f_p > 0} b_p(f_p) = \max_{e: f_e > 0} d_e(s_e)$ . For ease of notation, for bottleneck CGs, we may use  $B(s)$  and  $B(f)$  instead of  $SC(s)$  and  $SC(f)$  respectively.

**Optimal Solutions.** A configuration that minimizes the social cost function is an optimum configuration called OPT. Similar, the optimal flow is defined as the flow that minimizes the social cost function. PNE are considered as the possible outcomes of the game, yet they do not necessarily minimize social cost. This causes inefficiency to the network. To capture this inefficiency there are two measures, one adopting a worst case approach (PoA) and the other a best case approach (PoS).

**Price of Anarchy (PoA) and Price of Stability (PoS).** By letting  $x$  denote a configuration for the case of atomic CGs and a flow for the case of non atomic CGs, define

$$PoA = \max \left\{ \frac{SC(x)}{SC(OPT)} \mid x \text{ is a PNE} \right\} \quad PoS = \min \left\{ \frac{SC(x)}{SC(OPT)} \mid x \text{ is a PNE} \right\}$$

The PoA of symmetric non atomic additive costs CGs is independent of the structure of the network as it was first shown in [74]. Correa et al. in [28] prove a general tight bound for the PoA based only on the class  $\mathcal{D}$  of latency functions, which is  $\rho(\mathcal{D}) = (1 - \beta(\mathcal{D}))^{-1}$ , where  $\beta(\mathcal{D}) = \sup_{d \in \mathcal{D}, x \geq y \geq 0} \frac{y(d(x) - d(y))}{xd(x)}$ . The same bound holds for the PoS in symmetric atomic network CGs and for the PoA on games on extension parallel networks as shown in [39]. See also e.g. [22] and [79] for similar results for atomic CGs.

For bottleneck network CGs, although the PoS is equal to 1 (see e.g. [11, Corollary 2]) the PoA behaves way much worse as simple examples give a tight bound of  $\Omega(|V|)$  (see figure 15.2 or e.g. [27, Figure 2]), where  $|V|$  is the number of vertices of the network.





# Chapter 11

## On the Hardness of Network Design for Bottleneck Routing Games

In this chapter, we investigate the computational complexity and the approximability of the network design problem for non-atomic bottleneck routing games, where the individual cost of each player is the bottleneck cost of her path, and the social cost is the bottleneck cost of the network, i.e. the maximum latency of a used edge.

We first show that bottleneck routing games do not suffer from Braess's paradox either if the network is series-parallel, or if we consider only subpath-optimal Nash flows, a subclass of Nash flows (formally defined in section 11.1).

On the negative side, we prove that even for games with strictly increasing linear latencies, it is NP-hard not only to recognize instances suffering from the paradox, but also to distinguish between instances for which the Price of Anarchy (PoA) can decrease to 1 and instances for which the PoA cannot be improved by edge removal, even if their PoA is as large as  $\Omega(n^{0.121})$ . This implies that the network design problem for linear bottleneck routing games is NP-hard to approximate within a factor of  $O(n^{0.121-\epsilon})$ , for any constant  $\epsilon > 0$ . The proof is based on a recursive construction of hard instances that carefully exploits the properties of bottleneck routing games, and may be of independent interest.

On the positive side, we present an algorithm for finding a subnetwork that is almost optimal w.r.t. the bottleneck cost of its worst Nash flow, when the worst Nash flow in the best subnetwork routes a non-negligible amount of flow on all used edges. We show that the running time is essentially determined by the total number of paths in the network, and is quasipolynomial when the number of paths is quasipolynomial.

## 11.1 Problem-Specific Definitions and Facts

We deal with a typical instance of a non-atomic *bottleneck routing game*,  $\mathcal{G} = (G(V, E), (d_e)_{e \in E}, r)$ .

**Optimal and Nash Flow Properties.** Let  $o$  denote the optimal flow of an instance  $\mathcal{G}$ . We let  $B^*(\mathcal{G}) = B(o)$ . We note that for every subinstance  $\mathcal{H}$  of  $\mathcal{G}$ ,  $B^*(\mathcal{H}) \geq B^*(\mathcal{G})$ .

As noted earlier, in a Nash flow  $f$  all players incur a common bottleneck cost, i.e.  $B(f) = \min_p b_p(f)$ , and for every  $s - t$  path  $p'$ ,  $B(f) \leq b_{p'}(f)$ . We observe that if a flow  $f$  is a Nash flow for an  $s - t$  network  $G(V, E)$ , then the set of edges  $e$  with  $d_e(f_e) \geq B(f)$  comprises an  $s - t$  cut in  $G$ . For the converse, if for some flow  $f$ , there is an  $s - t$  cut consisting of edges  $e$  either with  $f_e > 0$  and  $d_e(f_e) = B(f)$ , or with  $f_e = 0$  and  $d_e(f_e) \geq B(f)$ , then  $f$  is a Nash flow. Moreover, for all bottleneck routing games with linear latencies  $a_e x$ , a flow  $f$  is a Nash flow iff the set of edges  $e$  with  $d_e(f_e) = B(f)$  comprises an  $s - t$  cut.

It can be shown that every bottleneck routing game admits at least one Nash flow (see e.g., [27, Proposition 2]), and that there is an optimal flow that is also a Nash flow (see e.g., [11, Corollary 2]). In general, a bottleneck routing game admits many different Nash flows, each with a possibly different bottleneck cost of the players. Given an instance  $\mathcal{G}$ , we let  $B(\mathcal{G})$  denote the bottleneck cost of the players in the worst Nash flow of  $\mathcal{G}$ , i.e. the Nash flow  $f$  that maximizes  $B(f)$  among all Nash flows. We refer to  $B(\mathcal{G})$  as the worst equilibrium bottleneck cost of  $\mathcal{G}$ . For convenience, for an instance  $\mathcal{G} = (G, c, r)$ , we sometimes write  $B(G, r)$ , instead of  $B(\mathcal{G})$ , to denote the worst equilibrium bottleneck cost of  $\mathcal{G}$ . We note that for every subinstance  $\mathcal{H}$  of  $\mathcal{G}$ ,  $B^*(\mathcal{G}) \leq B^*(\mathcal{H})$ , and that there may be subinstances  $\mathcal{H}$  with  $B(\mathcal{H}) < B(\mathcal{G})$ , which is the essence of Braess's paradox (see e.g., Fig. 12.1).

The following proposition considers the effect of a uniform scaling of the latency functions.

**Proposition 9.** *Let  $\mathcal{G} = (G, c, r)$  be a routing instance, let  $a > 0$ , and let  $\mathcal{G}' = (G, ac, r)$  be the routing instance obtained from  $\mathcal{G}$  if we replace the latency function  $d_e(x)$  of each edge  $e$  with  $ad_e(x)$ . Then, any  $\mathcal{G}$ -feasible flow  $f$  is also  $\mathcal{G}'$ -feasible and has  $B_{\mathcal{G}'}(f) = aB_{\mathcal{G}}(f)$ . Moreover, a flow  $f$  is a Nash flow (resp. optimal flow) of  $\mathcal{G}$  iff  $f$  is a Nash flow (resp. optimal flow) of  $\mathcal{G}'$ .*

*Proof.* Since the traffic rate of both  $\mathcal{G}$  and  $\mathcal{G}'$  is  $r$ , any  $\mathcal{G}$ -feasible flow  $f$  is also  $\mathcal{G}'$ -feasible. Moreover, the  $\mathcal{G}'$ -latency of  $f$  on each edge  $e$  is  $ad_e(f_e)$ . This immediately implies that  $B_{\mathcal{G}'}(f) = aB_{\mathcal{G}}(f)$ , and that  $f$  is a Nash flow (resp. optimal flow) of  $\mathcal{G}$  iff  $f$  is a Nash flow (resp. optimal flow) of  $\mathcal{G}'$ .  $\square$

**Subpath-Optimal Nash Flows.** For a flow  $f$  and any vertex  $u$ , let  $b_f(u)$  denote the minimum bottleneck cost of  $f$  among all  $s - u$  paths. The flow  $f$  is a *subpath-optimal Nash flow* [27] if for any vertex  $u$  and any  $s - t$  path  $p$  with  $f_p > 0$  that includes  $u$ , the bottleneck cost of the  $s - u$  part of  $p$  is  $b_f(u)$ . For example, the Nash flow  $f$  in Fig. 12.1.a is not subpath-optimal, because  $b_f(v) = 0$ , through the edge  $(s, v)$ , while the bottleneck cost of the path  $(s, u, v)$  is 1. For this instance, the only subpath-optimal Nash flow is the optimal flow with  $1/2$  unit on the path  $(s, u, t)$  and  $1/2$  unit on the path  $(s, v, t)$ .

We formally define the problems we will see

**Problem Definitions.**

- **Paradox-Ridden Recognition** (ParRidBC): Given an instance  $\mathcal{G}$ , decide if  $\mathcal{G}$  is paradox-ridden.
- **Best Subnetwork** (BSubNBC): Given an instance  $\mathcal{G}$ , find the best subnetwork  $H^*$  of  $G$ .

We investigate the complexity and the approximability of these fundamental selfish network design problems for bottleneck routing games.

We note that the objective function of BSubNBC is the worst equilibrium bottleneck cost  $B(H, r)$  of a subnetwork  $H$ . Thus, a (polynomial-time) algorithm  $A$  achieves an  $a$ -approximation for BSubNBC if for all instances  $\mathcal{G}$ ,  $A$  returns a subnetwork  $H$  with  $B(H, r) \leq aB(H^*, r)$ . A subtle point is that given a subnetwork  $H$ , we do not know how to efficiently compute the worst equilibrium bottleneck cost  $B(H, r)$  (see also [10, 52], where a similar issue arises). To deal with this delicate issue, our hardness results use a certain subnetwork structure to identify a good approximation to BSubNBC.

**Series-Parallel Networks.** A directed  $s - t$  network is *series-parallel* if it either consists of a single edge  $(s, t)$  or can be obtained from two series-parallel graphs with terminals  $(s_1, t_1)$  and  $(s_2, t_2)$  composed either in series or in parallel. In a *series composition*,  $t_1$  is identified with  $s_2$ ,  $s_1$  becomes  $s$ , and  $t_2$  becomes  $t$ . In a *parallel composition*,  $s_1$  is identified with  $s_2$  and becomes  $s$ , and  $t_1$  is identified with  $t_2$  and becomes  $t$ .

## 11.2 Paradox-Free Network Topologies and Paradox-Free Nash Flows

We start by discussing two interesting cases where Braess's paradox does not occur. We first show that if we have a bottleneck routing game  $\mathcal{G}$  de-

defined on an  $s - t$  series-parallel network, then  $\rho(\mathcal{G}) = 1$ , and thus Braess's paradox does not occur. We recall that this was also pointed out in [31] for the case of atomic unsplittable bottleneck routing games. Moreover, we note that a directed  $s - t$  network is series-parallel iff it does not contain a  $\partial$ -graph with degree-2 terminals as a topological minor. Therefore, the example in Fig. 12.1 demonstrates that series-parallel networks is the largest class of network topologies for which Braess's paradox does not occur (see also [64] for a similar result for the case of additive routing games).

**Proposition 10.** *Let  $\mathcal{G}$  be bottleneck routing game on an  $s - t$  series-parallel network. Then,  $\rho(\mathcal{G}) = 1$ .*

*Proof.* Let  $f$  be any Nash flow of  $\mathcal{G}$ . We use induction on the series-parallel structure of the network  $G$ , and show that  $f$  is an optimal flow w.r.t the bottleneck cost, i.e., that  $B(f) = B^*(\mathcal{G})$ . For the basis, we observe that the claim holds if  $G$  consists of a single edge  $(s, t)$ . For the inductive step, we distinguish two cases, depending on whether  $G$  is obtained by the series or the parallel composition of two series-parallel networks  $G_1$  and  $G_2$ .

**Series Composition.** First, we consider the case where  $G$  is obtained by the series composition of an  $s - t'$  series-parallel network  $G_1$  and a  $t' - t$  series-parallel network  $G_2$ . We let  $f_1$  and  $f_2$ , both of rate  $r$ , be the restrictions of  $f$  into  $G_1$  and  $G_2$ , respectively.

We start with the case where  $B(f) = B(f_1) = B(f_2)$ . Then, either  $f_1$  is a Nash flow in  $G_1$ , or  $f_2$  is a Nash flow in  $G_2$ . Otherwise, there would be a  $s - t'$  path  $p_1$  in  $G_1$  with bottleneck cost  $b_{p_1}(f_1) < B(f_1)$ , and an  $t' - t$  path  $p_2$  in  $G_2$ , with bottleneck cost  $b_{p_2}(f_2) < B(f_2)$ . Combining  $p_1$  and  $p_2$ , we obtain an  $s - t$  path  $p = p_1 \cup p_2$  in  $G$  with bottleneck cost smaller than  $B(f)$ , which contradicts the hypothesis that  $f$  is a Nash flow of  $\mathcal{G}$ . If  $f_1$  (or  $f_2$ ) is a Nash flow in  $G_1$  (resp.  $G_2$ ), then by induction hypothesis  $f_1$  (resp.  $f_2$ ) is an optimal flow in  $G_1$  (resp. in  $G_2$ ), and thus  $f$  is an optimal flow of  $\mathcal{G}$ .

Otherwise, we assume, without loss of generality, that  $B(f) = B(f_1) < B(f_2)$ . Then,  $f_1$  is a Nash flow in  $G_1$ . Otherwise, there would be an  $s - t'$  path  $p_1$  in  $G_1$  with bottleneck cost  $b_{p_1}(f_1) < B(f_1)$ , which could be combined with any  $t' - t$  path  $p_2$  in  $G_2$ , with bottleneck cost  $B(f_2) < B(f_1)$ , into an  $s - t$  path  $p = p_1 \cup p_2$  with bottleneck cost smaller than  $B(f)$ . The existence of such a path  $p$  contradicts the hypothesis that  $f$  is a Nash flow of  $\mathcal{G}$ . Therefore, by induction hypothesis  $f_1$  is an optimal flow in  $G_1$ , and thus  $f$  is an optimal flow of  $\mathcal{G}$ .

**Parallel Composition.** Next, we consider the case where  $G$  is obtained by the parallel composition of an  $s - t$  series-parallel network  $G_1$  and an  $s - t$  series-parallel network  $G_2$ . We let  $f_1$  and  $f_2$  be the restriction of  $f$  into

$G_1$  and  $G_2$ , respectively, let  $r_1$  (resp.  $r_2$ ) be the rate of  $f_1$  (resp.  $f_2$ ), and let  $\mathcal{G}_1$  (resp.  $\mathcal{G}_2$ ) be the corresponding routing instance. Then, since  $f$  is a Nash flow of  $\mathcal{G}$ ,  $f_1$  and  $f_2$  are Nash flows of  $\mathcal{G}_1$  and  $\mathcal{G}_2$  respectively, and  $B(f_1) = B(f_2) = B(f)$ . Therefore, by the induction hypothesis,  $f_1$  and  $f_2$  are optimal flows of  $\mathcal{G}_1$  and  $\mathcal{G}_2$ , and  $f$  is an optimal flow of  $\mathcal{G}$ . To see this, we observe that any flow different from  $f$  must route more flow through either  $G_1$  or  $G_2$ . But if the flow through e.g.  $G_1$  is more than  $r_1$ , the bottleneck cost through  $G_1$  would be at least as large as  $B(f_1)$ .  $\square$

Next, we show that any subpath-optimal Nash flow achieves a minimum bottleneck cost, and thus Braess's paradox does not occur if we restrict ourselves to subpath-optimal Nash flows.

**Proposition 11.** *Let  $\mathcal{G}$  be bottleneck routing game, and let  $f$  be any subpath-optimal Nash flow of  $\mathcal{G}$ . Then,  $B(f) = B^*(\mathcal{G})$ .*

*Proof.* Let  $f$  be any subpath-optimal Nash flow of  $\mathcal{G}$ , let  $S$  be the set of vertices reachable from  $s$  via edges with bottleneck cost less than  $B(f)$ , let  $\delta^+(S)$  be the set of edges  $e = (u, v)$  with  $u \in S$  and  $v \notin S$ , and let  $\delta^-(S)$  be the set of edges  $e = (u, v)$ , with  $u \notin S$  and  $v \in S$ . Then, in [27, Lemma 4.5], it is shown that (i)  $(S, V \setminus S)$  is an  $s - t$  cut, (ii) for all edges  $e \in \delta^+(S)$ ,  $d_e(f_e) \geq B(f)$ , (iii) for all edges  $e \in \delta^+(S)$  with  $f_e > 0$ ,  $d_e(f_e) = B(f)$ , and (iv) for all edges  $e \in \delta^-(S)$ ,  $f_e = 0$ .

By (i) and (iv), any optimal flow  $o$  routes at least as much traffic as the subpath-optimal Nash flow  $f$  routes through the edges in  $\delta^+(S)$ . Thus, there is some edge  $e \in \delta^+(S)$  with  $o_e \geq f_e$ , which implies that  $d_e(o_e) \geq d_e(f_e) \geq B(f)$ , where the second inequality follows from (ii). Since  $B^*(\mathcal{G}) = B(o) \geq d_e(o_e)$ , we obtain that  $B^*(\mathcal{G}) = B(f)$ .  $\square$

### 11.3 Recognizing Paradox-Ridden Instances is Hard

In this section, we show that given a linear bottleneck routing game  $\mathcal{G}$ , it is NP-hard not only to decide whether  $\mathcal{G}$  is paradox-ridden, but also to approximate the best subnetwork within a factor less than  $4/3$ . To this end, we employ a reduction from the 2-Directed Disjoint Paths problem (2-DDP), where we are given a directed network  $D$  and distinguished vertices  $s_1, s_2, t_1, t_2$ , and ask whether  $D$  contains a pair of vertex-disjoint paths connecting  $s_1$  to  $t_1$  and  $s_2$  to  $t_2$ . 2-DDP was shown NP-complete in [37, Theorem 3], even if the network  $D$  is known to contain two edge-disjoint paths connecting  $s_1$  to  $t_2$  and  $s_2$  to  $t_1$ . In the following, we say that a subnetwork  $D'$  of  $D$  is *good* if  $D'$  contains (i) at least one path outgoing from each of  $s_1$

and  $s_2$  to either  $t_1$  or  $t_2$ , (ii) at least one path incoming to each of  $t_1$  and  $t_2$  from either  $s_1$  or  $s_2$ , and (iii) either no  $s_1 - t_2$  paths or no  $s_2 - t_1$  paths. We say that  $D'$  is *bad* if any of these conditions is violated by  $D'$ . We note that we can efficiently check whether a subnetwork  $D'$  of  $D$  is good, and that a good subnetwork  $D'$  serves as a certificate that  $D$  is a YES-instance of 2-DDP. Then, the following lemma directly implies the hardness result of this section.

**Lemma 11.1.** Let  $\mathcal{I} = (D, s_1, s_2, t_1, t_2)$  be any 2-DDP instance. Then, we can construct, in polynomial time, an  $s - t$  network  $G(V, E)$  with a linear latency function  $d_e(x) = a_e x$ ,  $a_e > 0$ , on each edge  $e$ , so that for any traffic rate  $r > 0$ , the bottleneck routing game  $\mathcal{G} = (G, c, r)$  has  $B^*(\mathcal{G}) = r/4$ , and:

1. If  $\mathcal{I}$  is a YES-instance of 2-DDP, there exists a subnetwork  $H$  of  $G$  with  $B(H, r) = r/4$ .
2. If  $\mathcal{I}$  is a NO-instance of 2-DDP, for all subnetworks  $H'$  of  $G$ ,  $B(H', r) \geq r/3$ .
3. For all subnetworks  $H'$  of  $G$ , either  $H'$  contains a good subnetwork of  $D$ , or  $B(H', r) \geq r/3$ .

*Proof.* We construct a network  $G(V, E)$  with the desired properties by adding 4 vertices,  $s, t, v, u$ , to  $D$  and 9 “external” edges  $e_1 = (s, u)$ ,  $e_2 = (u, v)$ ,  $e_3 = (v, t)$ ,  $e_4 = (s, v)$ ,  $e_5 = (v, s_1)$ ,  $e_6 = (s, s_2)$ ,  $e_7 = (t_1, u)$ ,  $e_8 = (u, t)$ ,  $e_9 = (t_2, t)$  (see also Fig. 11.1.a). The external edges  $e_1$  and  $e_3$  have latency  $d_{e_1}(x) = d_{e_3}(x) = x/2$ . The external edges  $e_4, \dots, e_9$  have latency  $d_{e_i} = x$ . The external edge  $e_2$  and each edge  $e$  of  $D$  have latency  $d_{e_2}(x) = d_e(x) = \varepsilon x$ , for some  $\varepsilon \in (0, 1/4)$ .

We first show that  $B^*(\mathcal{G}) = r/4$ . As for the lower bound, since the edges  $e_1, e_4$ , and  $e_6$  form an  $s - t$  cut in  $G$ , every  $\mathcal{G}$ -feasible flow has a bottleneck cost of at least  $r/4$ . As for the upper bound, we may assume that  $D$  contains an  $s_1 - t_2$  path  $p$  and an  $s_2 - t_1$  path  $q$ , which are edge-disjoint (see also [37, Theorem 3]). Then, we route a flow of  $r/4$  through each of the paths  $(e_4, e_5, p, e_9)$  and  $(e_6, q, e_7, e_8)$ , and a flow of  $r/2$  through the path  $(e_1, e_2, e_3)$ , which gives a bottleneck cost of  $r/4$ .

Next, we show (1), namely that if  $\mathcal{I}$  is a YES-instance of 2-DDP, then there exists a subnetwork  $H$  of  $G$  with  $B(H, r) = r/4$ . By hypothesis, there is a pair of vertex-disjoint paths in  $D$ ,  $p$  and  $q$ , connecting  $s_1$  to  $t_1$ , and  $s_2$  to  $t_2$ . Let  $H$  be the subnetwork of  $G$  that includes all external edges and only the edges of  $p$  and  $q$  from  $D$  (see also Fig. 11.1.b). We let  $\mathcal{H} = (H, c, r)$  be the corresponding subinstance of  $\mathcal{G}$ . The flow routing  $r/4$  units through

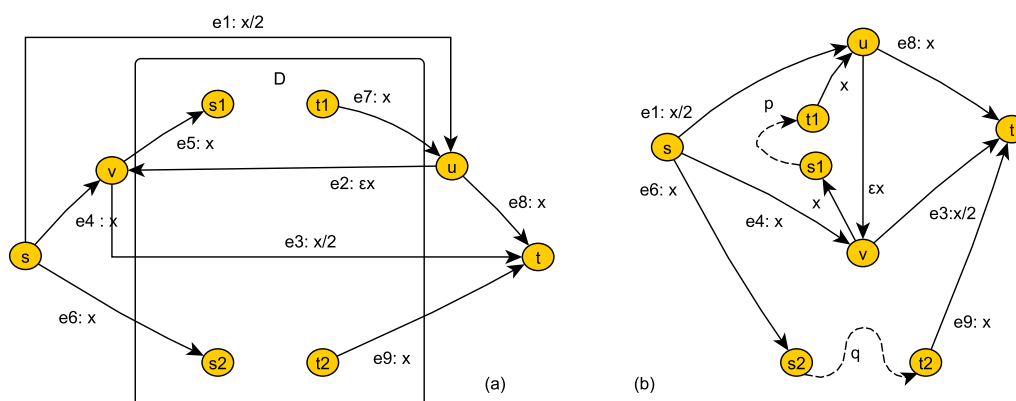

**Figure 11.1:** (a) The network  $G$  constructed in the proof of Lemma 11.1. (b) The best subnetwork of  $G$ , with  $\text{PoA} = 1$ , for the case where  $D$  contains a pair of vertex-disjoint paths connecting  $s_1$  to  $t_1$  and  $s_2$  to  $t_2$ .

each of the paths  $(e_4, e_5, p, e_7, e_8)$  and  $(e_6, q, e_9)$ , and  $r/2$  units through the path  $(e_1, e_2, e_3)$ , is an  $\mathcal{H}$ -feasible Nash flow with a bottleneck cost of  $r/4$ .

We proceed to show that any Nash flow of  $\mathcal{H}$  achieves a bottleneck cost of  $r/4$ . For sake of contradiction, let  $f$  be a Nash flow of  $\mathcal{H}$  with  $B(f) > r/4$ . Since  $f$  is a Nash flow, the edges  $e$  with  $d_e(f_e) \geq B(f)$  form an  $s - t$  cut in  $H$ . Since the bottleneck cost of  $e_2$  and of any edge in  $p$  and  $q$  is at most  $r/4$ , this cut includes either  $e_6$  or  $e_9$  (or both), either  $e_1$  or  $e_3$  (or both), and either  $e_4$  or  $e_8$  (or  $e_5$  or  $e_6$ , in certain combinations with other edges). Let us consider the case where this cut includes  $e_1, e_4$ , and  $e_6$ . Since the bottleneck cost of these edges is greater than  $r/4$ , we have more than  $r/2$  units of flow through  $e_1$  and more than  $r/4$  units of flow through each of  $e_4$  and  $e_6$ . Hence, we obtain that more than  $r$  units of flow leave  $s$ , a contradiction. All other cases are similar.

To conclude the proof, we have also to show (3), namely that for any subnetwork  $H'$  of  $G$ , if  $H'$  does not contain a good subnetwork of  $D$ , then  $B(H', r) \geq r/3$ . We observe that (3) implies (2), because if  $\mathcal{I}$  is a NO-instance, any two paths,  $p$  and  $q$ , connecting  $s_1$  to  $t_1$  and  $s_2$  to  $t_2$ , have some vertex in common, and thus,  $D$  includes no good subnetworks. To show (3), we let  $H'$  be any subnetwork of  $G$ , and let  $\mathcal{H}'$  be the corresponding subinstance of  $\mathcal{G}$ . We first show that either  $H'$  contains (i) all external edges, (ii) at least one path outgoing from each of  $s_1$  and  $s_2$  to either  $t_1$  or  $t_2$ , and (iii) at least one path incoming to each of  $t_1$  and  $t_2$  from either  $s_1$  or  $s_2$ , or  $H'$  includes a “small”  $s - t$  cut, and thus any  $\mathcal{H}'$ -feasible flow  $f$  has  $B(f) \geq r/3$ .

To prove (i), we observe that if some of the edges  $e_1, e_4$ , and  $e_6$  is missing from  $H'$ ,  $r$  units of flow are routed through the remaining ones,

which results in a bottleneck cost of at least  $r/3$ . The same argument applies to the edges  $e_3$ ,  $e_8$ , and  $e_9$ . Similarly, if  $e_2$  is not present in  $H'$ , the edges  $e_4$ ,  $e_6$ , and  $e_8$  form an  $s - t$  cut, and routing  $r$  units of flow through them causes a bottleneck cost of at least  $r/3$ . Therefore, we can assume, without loss of generality, that all these external edges are present in  $H'$ .

Now, let us focus on the external edges  $e_5$  and  $e_7$ . If  $e_5$  is not present in  $H'$  and there is a path  $p$  outgoing from  $s_2$  to either  $t_1$  or  $t_2$ , routing  $2r/3$  units of flow through the path  $(e_1, e_2, e_3)$  and  $r/3$  units through the path  $(e_6, p, e_9)$  (or through the path  $(e_6, p, e_7, e_8)$ ) is a Nash flow with a bottleneck cost of  $r/3$  (see also Fig. 11.2.a). If  $s_2$  is connected to neither  $t_1$  nor  $t_2$  (no matter whether  $e_5$  is present in  $H'$  or not), the edges  $e_1$  and  $e_4$  form an  $s - t$  cut, and thus, any  $\mathcal{H}'$ -feasible flow has a bottleneck cost of at least  $r/3$ . Similarly, we can show that if either  $e_7$  is not present in  $H'$ , or neither  $s_1$  nor  $s_2$  is connected to  $t_2$ , any  $\mathcal{H}'$ -feasible flow has a bottleneck cost of at least  $r/3$ . Therefore, we can assume, without loss of generality, that all external edges are present in  $H'$ , and that  $H'$  includes at least one path outgoing from  $s_2$  to either  $t_1$  or  $t_2$ , and at least one path incoming to  $t_2$  from either  $s_1$  or  $s_2$ .

Similarly, we can assume, without loss of generality, that  $H'$  includes at least one path outgoing from  $s_1$  to either  $t_1$  or  $t_2$ , and at least one path incoming to  $t_1$  from either  $s_1$  or  $s_2$ . E.g., if  $s_1$  is connected to neither  $t_1$  nor  $t_2$ , routing  $2r/3$  units of flow through the path  $(e_1, e_2, e_3)$  and  $r/3$  units through  $s_2$  and either  $t_1$  or  $t_2$  (or both) is a Nash flow with a bottleneck cost of  $r/3$ . A similar argument applies to the case where neither  $s_1$  nor  $s_2$  is connected to  $t_1$ .

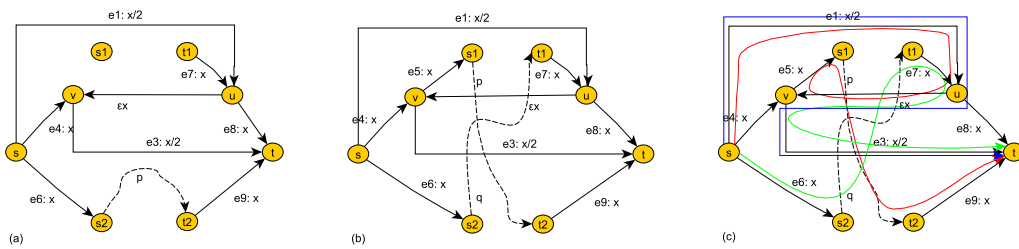

**Figure 11.2:** Possible subnetworks of  $G$  when there is no pair of vertex-disjoint paths connecting  $s_1$  to  $t_1$  and  $s_2$  to  $t_2$ . The subnetwork (a) contains an  $s_2 - t_2$  path and does not include  $e_5$ . In the subnetwork (b), we essentially have all edges of  $G$ . In (c), we depict a Nash flow that consists of three paths, each carrying  $r/3$  units of flow, and has a bottleneck cost of  $r/3$ .

Let us now consider a subnetwork  $H'$  of  $G$  that does not contain a good



subnetwork of  $D$ , but it contains (i) all external edges, (ii) at least one path outgoing from each of  $s_1$  and  $s_2$  to either  $t_1$  or  $t_2$ , and (iii) at least one path incoming to each of  $t_1$  and  $t_2$  from either  $s_1$  or  $s_2$ . By (ii) and (iii), and the hypothesis that the subnetwork of  $D$  included in  $H'$  is bad,  $H'$  contains an  $s_1 - t_2$  path  $p$  and an  $s_2 - t_1$  path  $q$  (see also Fig. 11.2.b). At the intuitive level, this corresponds to the case where no edges are removed from  $G$ . Then, routing  $r/3$  units of flow on each of the  $s-t$  paths  $(e_1, e_2, e_3)$ ,  $(e_1, e_2, e_5, p, e_9)$ , and  $(e_6, q, e_7, e_2, e_3)$  has a bottleneck cost of  $r/3$  and is a Nash flow, because the set of edges with bottleneck cost  $r/3$  comprises an  $s-t$  cut (see also Fig. 11.2.c). Therefore, we have shown part (3) of the lemma, which in turn, immediately implies part (2).  $\square$

We note that the bottleneck routing game  $\mathcal{G}$  in the proof of Lemma 11.1 has  $\rho(\mathcal{G}) = 4/3$ , and is paradox-ridden, if  $\mathcal{I}$  is a YES instance of 2-DDP, and paradox-free, otherwise. Thus, we obtain that:

**Theorem 11.2.** Deciding whether a bottleneck routing game with strictly increasing linear latencies is paradox-ridden is NP-hard.

Moreover, Lemma 11.1 implies that it is NP-hard to approximate BSubNBC within a factor less than  $4/3$ . The subtle point here is that given a subnetwork  $H$ , we do not know how to efficiently compute the worst equilibrium bottleneck cost  $B(H, r)$ . However, we can use the notion of a good subnetwork of  $D$  and deal with this issue. Specifically, let  $A$  be any approximation algorithm for BSubNBC with approximation ratio less than  $4/3$ . Then, if  $D$  is a YES-instance of 2-DDP,  $A$  applied to the network  $G$ , constructed in the proof of Lemma 11.1, returns a subnetwork  $H$  with  $B(H, r) < r/3$ . Thus, by Lemma 11.1,  $H$  contains a good subnetwork of  $D$ , which can be checked in polynomial time. If  $D$  is a NO-instance,  $D$  contains no good subnetworks. Hence, the outcome of  $A$  would allow us to distinguish between YES and NO instances of 2-DDP.

**Remark 11.3.** If we let the edges to have more general latency functions, such as polynomials of greater degree or exponential functions, then we can get greater inapproximability factors for BSubNBC.

For example, if we use the cost functions  $x^d$  instead of  $x$  and  $x^d/2^d$  instead of  $x/2$  in network  $G$  in the proof of Lemma 11.1 (fig. 11.1), then we will get an inapproximability ratio of  $(4/3)^d$ .

Using  $a^x$  instead of  $x$  and  $a^{x/2}$  instead of  $x/2$  in the proof of Lemma 11.1 (fig. 11.1), we get an inapproximability ratio of  $a^{r/12} = B^*(\mathcal{G})^{1/3}$  (depending on  $a$  and  $r$ ).

## 11.4 Approximating the Best Subnetwork is Hard

Next, we apply essentially the same construction as in the proof of Lemma 11.1, but in a recursive way, and show that it is NP-hard to approximate BSubNBC for linear bottleneck routing games within a factor of  $O(n^{121-\varepsilon})$ , for any constant  $\varepsilon > 0$ . Throughout this section, we let  $\mathcal{I} = (D, s_1, s_2, t_1, t_2)$  be a 2-DDP instance, and let  $G$  be an  $s - t$  network, which includes (possibly many copies of)  $D$  and can be constructed from  $\mathcal{I}$  in polynomial time. We assume that  $G$  has a linear latency function  $d_e(x) = a_e x$ ,  $a_e > 0$ , on each edge  $e$ , and for any traffic rate  $r > 0$ , the bottleneck routing game  $\mathcal{G} = (G, c, r)$  has  $B^*(\mathcal{G}) = r/\gamma_1$ , for some  $\gamma_1 > 0$ . Moreover,

1. If  $\mathcal{I}$  is a YES-instance of 2-DDP, there exists a subnetwork  $H$  of  $G$  with  $B(H, r) = r/\gamma_1$ .
2. If  $\mathcal{I}$  is a NO-instance of 2-DDP, for all subnetworks  $H'$  of  $G$ ,  $B(H', r) \geq r/\gamma_2$ , for a  $\gamma_2 \in (0, \gamma_1)$ .
3. For all subnetworks  $H'$  of  $G$ , either  $H'$  contains at least one copy of a good subnetwork of  $D$ , or  $B(H', r) \geq r/\gamma_2$ .

The existence of such a network shows that it is NP-hard to approximate BSubNBC within a factor less than  $\gamma = \gamma_1/\gamma_2$ . Thus, we usually refer to  $G$  as a  $\gamma$ -gap instance (with linear latencies). For example, for the network  $G$  in the proof of Lemma 11.1,  $\gamma_1 = 4$  and  $\gamma_2 = 3$ , and thus  $G$  is a 4/3-gap instance. We next show that given  $\mathcal{I}$  and a  $\gamma_1/\gamma_2$ -gap instance  $G$ , we can construct a  $(4\gamma_1)/(3\gamma_2)$ -gap instance  $G'$ , i.e., we can amplify the inapproximability gap by a factor of 4/3.

**Lemma 11.4.** Let  $\mathcal{I} = (D, s_1, s_2, t_1, t_2)$  be a 2-DDP instance, and let  $G$  be a  $\gamma_1/\gamma_2$ -gap instance with linear latencies, based on  $\mathcal{I}$ . Then, we can construct, in time polynomial in the size of  $\mathcal{I}$  and  $G$ , an  $s - t$  network  $G'$  with a linear latency function  $d_e(x) = a_e x$ ,  $a_e > 0$ , on each edge  $e$ , so that for any traffic rate  $r > 0$ , the bottleneck routing game  $\mathcal{G}' = (G', c, r)$  has  $B^*(\mathcal{G}') = r/(4\gamma_1)$ , and:

1. If  $\mathcal{I}$  is a YES-instance of 2-DDP, there exists a subnetwork  $H$  of  $G'$  with  $B(H, r) = r/(4\gamma_1)$ .
2. If  $\mathcal{I}$  is a NO-instance of 2-DDP, for every subnetwork  $H'$  of  $G'$ ,  $B(H', r) \geq r/(3\gamma_2)$ .
3. For all subnetworks  $H'$  of  $G'$ , either  $H'$  contains at least one copy of a good subnetwork of  $D$ , or  $B(H', r) \geq r/(3\gamma_2)$ .

*Proof.* Starting from  $D$ , we obtain  $G'$  by applying the construction of Lemma 11.1, but with all external edges, except for  $e_2$ , replaced by a copy of the gap-instance  $G$ . For convenience, we refer to the copy of the gap-instance replacing the external edge  $e_i$ ,  $i \in \{1, 3, \dots, 9\}$ , as the *edgework*  $G_i$ . Formally, to obtain  $G'$ , we start from  $D$  and add four new vertices,  $s$ ,  $t$ ,  $v$ ,  $u$ . We connect  $s$  to  $u$ , with the  $s-u$  edgework  $G_1$ , and  $v$  to  $t$ , with the  $s-u$  edgework  $G_3$ , where in both  $G_1$  and  $G_3$ , we replace the latency function  $d_e(x)$  of each edge  $e$  in the gap instance with  $d_e(x)/2$  (this is because in Lemma 11.1, the external edges  $e_1$  and  $e_3$  have latencies  $x/2$ ). Moreover, instead of the external edge  $e_i$ ,  $i \in \{4, \dots, 9\}$ , we connect  $(s, v)$ ,  $(v, s_1)$ ,  $(s, s_2)$ ,  $(t_1, u)$ ,  $(u, t)$ , and  $(t_2, t)$  with the edgework  $G_i$ . The latencies in these edgeworks are as in the gap instance. Furthermore, we add the external edge  $e_2 = (u, v)$  with latency  $d_{e_2}(x) = \varepsilon x$ , for some  $\varepsilon \in (0, \frac{1}{4\gamma_1})$  (see also Fig. 11.3.a). Also, each edge  $e$  of  $D$  has latency  $d_e(x) = \varepsilon x$ . We next consider the corresponding routing instance  $\mathcal{G}'$  with an arbitrary traffic rate  $r > 0$ . Throughout the proof, when we define a routing instance, we omit, for simplicity, the coordinate  $c$ , referring to the latency functions, with the understanding that they are defined as above.

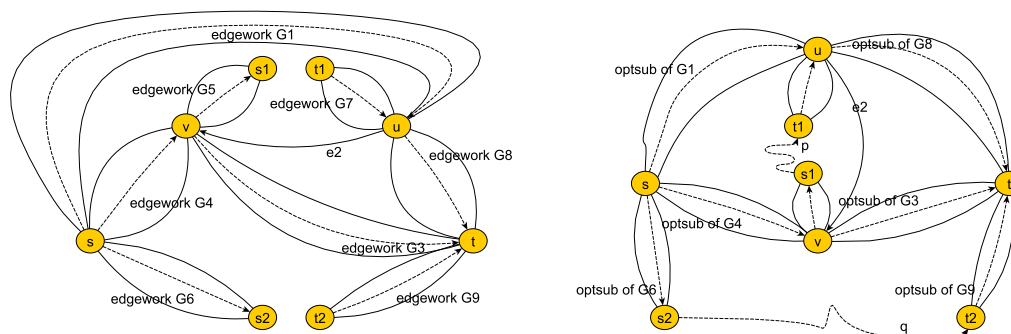

**Figure 11.3:** (a) The network  $G'$  constructed in the proof of Lemma 11.4. The structure of  $G'$  is similar to the structure of the network  $G$  in Fig. 11.1, with each external edge  $e_i$ , except for  $e_2$ , replaced by the edgework  $G_i$ . (b) The structure of a best subnetwork  $H$  of  $G'$ , with  $\text{PoA} = 1$ , when  $D$  contains a pair of vertex-disjoint paths,  $p$  and  $q$ , connecting  $s_1$  to  $t_1$  and  $s_2$  to  $t_2$ . To complete  $H$ , we use an optimal subnetwork (or simply, subedgework) of each edgework  $G_i$ .

Intuitively, each  $G_i$ ,  $i \in \{4, \dots, 9\}$ , behaves as an external edge (hence the term edge(network)), which at optimality has a bottleneck cost of  $r/\gamma_1$ , for any traffic rate  $r$  entering  $G_i$ . Moreover, if  $I$  is a YES-instance of 2-DDP, the edgework  $G_i$  has a subedgework  $H_i$  for which  $B(H_i, r) = r/\gamma_1$ , for any  $r$ , while if  $H_i$  does not contain any copies of a good subnetwork of  $D$  (or, if  $I$  is a NO-instance), for all subedgeworks  $H'_i$  of  $G_i$ ,  $B(H'_i, r) \geq r/\gamma_2$ , for any  $r$ .

The same holds for  $G_1$  and  $G_3$ , but with a worst equilibrium bottleneck cost of  $r/(2\gamma_1)$  in the former case, and of  $r/(2\gamma_2)$  in the latter case, because the latency functions of  $G_1$  and  $G_3$  are scaled by  $1/2$  (see also Proposition 9).

The proofs of the following propositions are conceptually similar to the proofs of the corresponding claims in the proof Lemma 11.1.

**Proposition 12.** *The optimal bottleneck cost of  $\mathcal{G}'$  is  $B^*(\mathcal{G}') = r/(4\gamma_1)$ .*

*Proof.* We have to show that  $B^*(\mathcal{G}') = r/(4\gamma_1)$ . For the upper bound, as in the proof of Lemma 11.1, we assume that  $D$  contains an  $s_1 - t_2$  path  $p$  and an  $s_2 - t_1$  path  $q$ , which are edge-disjoint. We route (i)  $r/4$  units of flow through the edgeworks  $G_4, G_5$ , next through the path  $p$ , and next through the edgework  $G_9$ , (ii)  $r/4$  units through the edgeworks  $G_6$ , next through the path  $q$ , and next through the edgeworks  $G_7$  and  $G_8$ , and (iii)  $r/2$  units through the edgework  $G_1$ , next through the external edge  $e_2$ , and next through the edgework  $G_3$ . These routes are edge(work)-disjoint, and if we route the flow optimally through each edgework, the bottleneck cost is  $r/(4\gamma_1)$ . As for the lower bound, we observe that the edgeworks  $H_1, H_4$ , and  $H_6$  essentially form an  $s - t$  cut in  $G'$ , and thus every feasible flow has a bottleneck cost of at least  $r/(4\gamma_1)$ .  $\square$

**Proposition 13.** *If  $\mathcal{I}$  is a YES-instance, there is a subnetwork  $H$  of  $G'$  with  $B(H, r) = r/(4\gamma_1)$ .*

*Proof.* If  $\mathcal{I}$  is a YES-instance of 2-DDP, then (i) there are two vertex-disjoint paths in  $D$ ,  $p$  and  $q$ , connecting  $s_1$  to  $t_1$  and  $s_2$  to  $t_2$ , and (ii) there is an optimal subnetwork (or simply, subedgework)  $H_i$  of each edgework  $G_i$  so that for any traffic rate  $r$  routed through  $H_i$ , the worst equilibrium bottleneck cost  $B(H_i, r)$  is  $r/\gamma_1$ , if  $i \in \{4, \dots, 9\}$ , and  $r/(2\gamma_1)$ , if  $i \in \{1, 3\}$ . Let  $H$  be the subnetwork of  $G'$  that consists of only the edges of the paths  $p$  and  $q$  from  $D$ , of the external edge  $e_2$ , and of the optimal subedgeworks  $H_i$ ,  $i \in \{1, 3, \dots, 9\}$  (see also Fig. 11.3.b). We observe that we can route: (i)  $r/4$  units of flow through the subedgeworks  $H_4, H_5$ , next through the path  $p$ , and next through the subedgeworks  $H_7$  and  $H_8$ , (ii)  $r/4$  units of flow through the subedgework  $H_6$ , next through the path  $q$ , and next through the subedgework  $H_9$ , and (iii)  $r/2$  units of flow through the subedgework  $H_1$ , next through the external edge  $e_2$ , and next through the subedgework  $H_3$ . These routes are edge(work)-disjoint, and if we use any Nash flow through each of the routing instances  $(H_i, r/4)$ ,  $i \in \{4, \dots, 9\}$ ,  $(H_1, r/2)$ , and  $(H_3, r/2)$ , we obtain a Nash flow of the instance  $(H, r)$  with a bottleneck cost of  $r/(4\gamma_1)$ .

We next show that any Nash flow of  $(H, r)$  has a bottleneck cost of at most  $r/(4\gamma_1)$ . To reach a contradiction, let us assume that some feasible

Nash flow  $f$  has bottleneck cost  $B(f) > r/(4\gamma_1)$ . We recall that  $f$  is a Nash flow iff the edges of  $G'$  with bottleneck cost  $B(f) > r/(4\gamma_1)$  form an  $s-t$  cut. This cut does not include the edges of the paths  $p$  and  $q$  and the external edge  $e_2$ , due to the choice of their latencies. Hence, this cut includes a similar cut either in  $H_6$  or in  $H_9$  (or in both), either in  $H_1$  or  $H_3$  (or in both), and either in  $H_4$  or in  $H_8$  (or in  $H_5$  or in  $H_6$ , in certain combinations with other subedgeworks, see also Fig. 11.3.b). Let us consider the case where the edges with bottleneck cost  $B(f) > r/(4\gamma_1)$  form a cut in  $H_1$ ,  $H_4$ , and  $H_6$ . Namely, the edges of  $H_1$ ,  $H_4$ , and  $H_6$ , with bottleneck cost equal to  $B(f) > r/(4\gamma_1)$  form an  $s-u$ , an  $s-v$ , and an  $s-s_2$  cut, respectively, and thus the restriction of  $f$  to each of  $H_1$ ,  $H_4$ , and  $H_6$ , is an equilibrium flow of bottleneck cost greater than  $r/(4\gamma_1)$  for the corresponding routing instance. Since  $\mathcal{I}$  is a YES-instance, this can happen only if the flow through  $H_1$  is more than  $r/2$ , and the flow through each of  $H_4$  and  $H_6$  is more than  $r/4$  (see also property (ii) of optimal subedgeworks above). Hence, we obtain that more than  $r$  units of flow leave  $s$ , a contradiction. All other cases are similar.  $\square$

The most technical part of the proof is to show (3), namely that for any subnetwork  $H'$  of  $G'$ , if  $H'$  does not contain any copies of a good subnetwork of  $D$ , then  $B(H', r) \geq r/(3\gamma_2)$ . This immediately implies (2), since if  $\mathcal{I}$  is a NO-instance of 2-DDP,  $D$  includes no good subnetworks. To prove (3), we consider any subnetwork  $H'$  of  $G'$ , and let  $H'_i$  be the subedgework of each  $G_i$  present in  $H'$ . We assume that the subedgeworks  $H'_i$  do not contain any copies of a good subnetwork of  $D$ , and show that if the subnetwork of  $D$  connecting  $s_1$  and  $s_2$  to  $t_1$  and  $t_2$  in  $H'$  is also bad, then  $B(H', r) \geq r/(3\gamma_2)$ .

At the technical level, we repeatedly use the idea of a flow  $f_i$  through a subedgework  $H'_i$  that “saturates”  $H'_i$ , in the sense that  $f_i$  is a Nash flow with bottleneck cost at least  $r_i/(3\gamma_2)$  for the subinstance  $(H'_i, r_i)$ . Formally, we say that a flow rate  $r_i$  saturates a subedgework  $H'_i$  if  $B(H'_i, r_i) \geq r_i/(3\gamma_2)$ . We refer to the flow rate  $r_i^s$  for which  $B(H'_i, r_i^s) = r_i^s/(3\gamma_2)$  as the *saturation rate* of  $H'_i$ . We note that the saturation rate  $r_i^s$  is well-defined, because the latency functions of  $G_i$ s are linear and strictly increasing. Moreover, by property (3) of gap instances, the saturation rate of each subedgework  $H'_i$  is  $r_i^s \leq r/3$ , if  $i \in \{4, \dots, 9\}$ , and  $r_i^s \leq 2r/3$ , if  $i \in \{1, 3\}$ . Thus, at the intuitive level, the subedgeworks  $H'_i$  behave as the external edges of the network constructed in the proof of Lemma 11.1. Hence, to show that  $B(H', r) \geq r/(3\gamma_2)$ , we need to construct a flow of rate (at most)  $r$  that saturates a collection of subedgeworks comprising an  $s-t$  cut in  $H'$ .

Our first step in this direction is to simplify the possible structure of  $H'$ .

**Proposition 14.** *Let  $H'$  be any subnetwork of  $G'$  whose subedgeworks  $H'_i$  do not contain any copies of a good subnetwork of  $D$ . Then, either the subnetwork  $H'$  contains (i) the external edge  $e_2$ , (ii) at least one path outgoing from each of  $s_1$  and  $s_2$  to either  $t_1$  or  $t_2$ , and (iii) at least one path incoming to each of  $t_1$  and  $t_2$  from either  $s_1$  or  $s_2$ , or  $B(H', r) \geq r/(3\gamma_2)$ .*

*Proof.* For convenience, in the proofs of Proposition 14 and Proposition 15, we slightly abuse the terminology, and say that a collection of subedgeworks of  $H'$  form an  $s - t$  cut, if the union of any cuts in them comprises an  $s - t$  cut in  $H'$ . Moreover, whenever we write that  $r_i$  units of flow are routed through a subedgework  $H_i$ , we assume that the routing through  $H_i$  corresponds to the worst Nash flow of  $(H_i, r_i)$ . Also, we recall that since subedgeworks  $H'_i$  do not contain any copies of a good subnetwork of  $D$ , by property (3) of gap instances, the saturation rate of each  $H'_i$  is  $r_i^s \leq r/3$ , if  $i \in \{4, \dots, 9\}$ , and  $r_i^s \leq 2r/3$ , if  $i \in \{1, 3\}$ .

We start by showing that either the external edge  $e_2$  is present in  $H'$ , or  $B(H', r) \geq r/(3\gamma_2)$ . Indeed, if  $e_2$  is not present in  $H'$ , the subedgeworks  $H'_4$ ,  $H'_6$ , and  $H'_8$  form an  $s - t$  cut in  $H'$ . Therefore, we can construct a Nash flow  $f$  that routes at least  $r/3$  units of flow through  $H'_4$ ,  $H'_6$ , and  $H'_8$ , and has  $B(f) \geq r/(3\gamma_2)$ . Therefore, we can assume, without loss of generality, that  $e_2$  is present in  $H'$ .

Similarly, we show that either  $H'$  includes at least one path outgoing from  $s_2$  to either  $t_1$  or  $t_2$ , and at least one path incoming to  $t_2$  from either  $s_1$  or  $s_2$ , or  $B(H', r) \geq r/(3\gamma_2)$ . In particular, if  $s_2$  is connected to neither  $t_1$  nor  $t_2$ , the subedgeworks  $H'_1$  and  $H'_4$  form an  $s - t$  cut in  $H'$ . Thus, we can construct a Nash flow  $f$  that saturates the subedgework  $H'_1$  (or the subedgeworks  $H'_3$  and  $H'_8$ , if  $r_1^s > r_3^s + r_8^s$ ) and the subedgework  $H'_4$  (or the subedgeworks  $H'_3$  and either  $H'_5$ , or  $H'_9$  and at least one of the  $H'_7$  and  $H'_8$ , depending on  $r_4^s$  and the saturation rates of the rest). We note that this is always possible with  $r$  units of flow, because  $r_1^s \leq 2r/3$  and  $r_4^s \leq r/3$ . Therefore, the bottleneck cost of  $f$  is  $B(f) \geq r/(3\gamma_2)$ . In case where there is no path incoming to  $t_2$  from either  $s_1$  or  $s_2$ , the subedgeworks  $H'_3$  and  $H'_8$  form an  $s - t$  cut in  $H'$ . As before, we can construct a Nash flow  $f$  that saturates the subedgeworks  $H'_3$  and  $H'_8$  (or, as before, an appropriate combination of other subedgeworks carrying flow to  $H'_3$  and  $H'_8$ ), and has  $B(f) \geq r/(3\gamma_2)$ . Therefore, we can assume, without loss of generality, that  $H'$  includes at least one path outgoing from  $s_2$  to either  $t_1$  or  $t_2$ , and at least one path incoming to  $t_2$  from either  $s_1$  or  $s_2$ .

Next, we show that either  $H'$  includes at least one path outgoing from  $s_1$  to either  $t_1$  or  $t_2$ , and at least one path incoming to  $t_1$  from either  $s_1$  or  $s_2$ , or  $B(H', r) \geq r/(3\gamma_2)$ . In particular, let us consider the case where  $s_1$

is connected to neither  $t_1$  nor  $t_2$  (see also Fig. 11.4.a, the case where there is no path incoming to  $t_1$  from either  $s_1$  or  $s_2$  can be handled similarly). In the following, we assume that  $s_2$  is connected to  $t_2$  (because, by the analysis above, we can assume that there is a path incoming to  $t_2$ , and  $s_1$  is not connected to  $T_2$ ), and construct a Nash flow  $f$  of bottleneck cost  $B(f) \geq r/(3\gamma_2)$ .

We first route  $\min\{r_6^s, r_9^s\} \leq r/3$  units of flow through the subedgework  $H'_6$ , next through an  $s_2 - t_2$  path, and finally through the subedgework  $H'_9$ , and saturate either  $H'_6$  or  $H'_9$  (or both). If there is an  $s_2 - t_1$  path and  $H'_6$  is not saturated, we keep routing flow through  $H'_6$ , next through an  $s_2 - t_1$  path, and next through the subedgeworks  $H'_7$  and  $H'_8$ , until either the subedgework  $H'_6$  or at least one of the subedgeworks  $H'_7$  and  $H'_8$  become saturated. Thus, we saturate at least one edgework on every  $s - t$  path that includes  $s_2$ .

Next, we show how to saturate at least one edgework on every  $s - t$  path that includes either  $v$  or  $u$ . If  $r_1^s \leq r_3^s \leq 2r/3$ , we route  $r_1^s$  units of flow through  $H'_1$ ,  $e_2$ , and  $H'_3$ , and route  $\min\{r_3^s - r_1^s, r_4^s\}$  units of flow through  $H'_4$  and  $H'_3$ , and saturate either  $H'_1$  and  $H'_3$  or  $H'_1$  and  $H'_4$ . If  $r_3^s < r_1^s \leq 2r/3$ , we route  $r_3^s$  units of flow through  $H'_1$ ,  $e_2$ , and  $H'_3$ , and route  $\min\{r_3^s - r_1^s, r_8^s\}$  units of flow through  $H'_1$  and  $H'_8$ , and saturate either  $H'_1$  and  $H'_3$  or  $H'_3$  and  $H'_8$ .

The remaining flow (if any) can be routed through these routes, in proportional rates. In all cases, we obtain an  $s - t$  cut consisting of saturated subedgeworks. Thus, the resulting flow  $f$  is a Nash flow with a bottleneck cost of at least  $r/(3\gamma_2)$ . □

Now, let us focus on a subnetwork  $H'$  of  $G'$  that contains (i) the external edge  $e_2$ , (ii) at least one path outgoing from each of  $s_1$  and  $s_2$  to either  $t_1$  or  $t_2$ , and (iii) at least one path incoming to each of  $t_1$  and  $t_2$  from either  $s_1$  or  $s_2$ . If the copy of the subnetwork of  $D$  connecting  $s_1$  and  $s_2$  to  $t_1$  and  $t_2$  in  $H'$  is also bad, properties (ii) and (iii) imply that  $H'$  contains an  $s_1 - t_2$  path  $p$  and an  $s_2 - t_1$  path  $q$ . In this case, the entire subnetwork  $H'$  essentially behaves as if it included all edges of  $G'$ . Then, a routing similar to that in Fig. 11.2.c gives a Nash flow with a bottleneck cost of  $r/(3\gamma_2)$ . This intuition is formalized by the following proposition.

**Proposition 15.** *Let  $H'$  be any subnetwork of  $G'$  that satisfies (i), (ii), and (iii) above, and does not contain any copies of a good subnetwork of  $D$ . Then  $B(H', r) \geq r/(3\gamma_2)$ .*

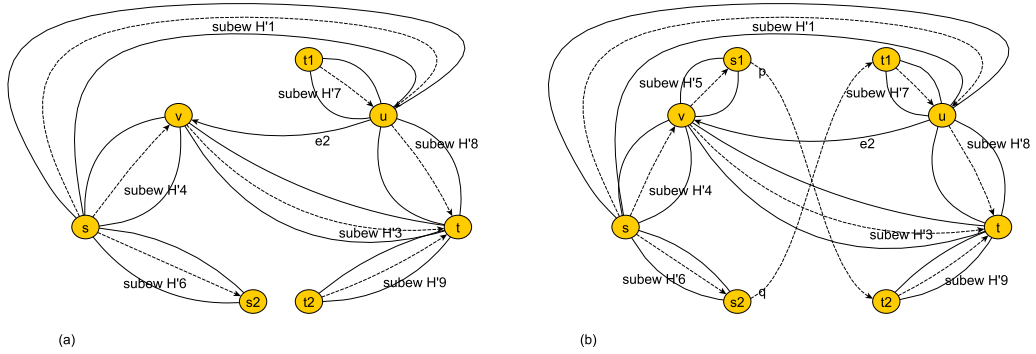

**Figure 11.4:** The structure of possible subnetworks of  $G'$  when there is no pair of vertex-disjoint paths connecting  $s_1$  to  $t_1$  and  $s_2$  to  $t_2$ . The subnetwork (a) contains a path outgoing from  $s_2$  to either  $t_1$  or  $t_2$ , and no path outgoing from  $s_1$  to either  $t_1$  or  $t_2$ . Hence, no flow can be routed through the edgework  $G_5$ , and thus we can regard  $G_5$  as being absent from  $H'$ . The subnetwork (b) essentially corresponds to the case where all edges of  $G'$  are present in  $H'$ .

*Proof.* In the following, we consider a subnetwork  $H'$  of  $G'$  which does not include any copies of a good subnetwork of  $D$ , and contains (i) the external edge  $e_2$ , (ii) at least one path outgoing from each of  $s_1$  and  $s_2$  to either  $t_1$  or  $t_2$ , and (iii) at least one path incoming to each of  $t_1$  and  $t_2$  from either  $s_1$  or  $s_2$ . Since the copy of the subnetwork of  $D$  connecting  $s_1$  and  $s_2$  to  $t_1$  and  $t_2$  in  $H'$  is bad, properties (ii) and (iii) imply that  $H'$  contains an  $s_1 - t_2$  path  $p$  and an  $s_2 - t_1$  path  $q$ . Moreover, since the subedgeworks  $H'_i$  do not include any copies of a good subnetwork of  $D$ , by property (3) of gap instances, the saturation rate of each  $H'_i$  is  $r_i^s \leq r/3$ , if  $i \in \{4, \dots, 9\}$ , and  $r_i^s \leq 2r/3$ , if  $i \in \{1, 3\}$ .

We next show that for such a subnetwork  $H'$ , we can construct a Nash flow  $f$  of bottleneck cost  $B(f) \geq r/(3\gamma_2)$ . At the conceptual level, as in the last case in the proof of Lemma 11.1, we seek to construct a Nash flow by routing  $r/3$  units of flow through each of the following three routes: (i)  $H'_1$ ,  $e_2$ , and  $H'_3$ , (ii)  $H'_1$ ,  $e_2$ ,  $H'_5$ ,  $p$ , and  $H'_9$ , and (iii)  $H'_6$ ,  $q$ ,  $H'_7$ ,  $e_2$ , and  $H'_3$ . However, for simplicity of the analysis, we regard the corresponding (edge) flow as being routed through just two routes: a rate of  $2r/3$  is routed through  $H'_1$ ,  $e_2$ , and  $H'_3$ , and a rate of  $r/3$  is routed through the (possibly non-simple) route  $H'_6$ ,  $q$ ,  $H'_7$ ,  $e_2$ ,  $H'_5$ ,  $p$ , and  $H'_9$ . We do so because the latter routing allows us to consider fewer cases in the analysis. We conclude the proof by showing that if the latter route is not simple, we can always decompose the flow into the three simple routes above.

In the following, we assume that with a flow rate of at most  $2r/3$ , routed through  $H'_1$ ,  $e_2$ , and  $H'_3$  (and possibly through  $H'_4$  and  $H'_8$ ), we can saturate



both subedgeworks  $H'_1$  and  $H'_3$ . Otherwise, as in the last case in the proof of Proposition 14, we can show how with a total flow rate of at most  $2r/3$ , part of which is routed through either  $H'_4$  or  $H'_8$ , we can saturate either  $H'_1$  and  $H'_4$ , or  $H'_3$  and  $H'_8$ . Then, the remaining  $r/3$  units of flow can saturate either  $H'_6$ , in the former case, or  $H'_9$ , in the latter case. Thus, we obtain a Nash flow with a bottleneck cost of at least  $r/(3\gamma_2)$ .

Having saturated both subedgeworks  $H'_1$  and  $H'_3$ , using at most  $2r/3$  units of flow, we have at least  $r/3$  units of flow to saturate the subedgeworks  $H'_5$ ,  $H'_6$ ,  $H'_7$ , and  $H'_9$ , or an appropriate subset of them, so that together with  $H'_1$  and  $H'_3$ , they form an  $s - t$  cut in  $H'$ . We first route  $\tau \equiv \min\{r_5^s, r_6^s, r_7^s, r_9^s\} \leq r/3$  units of flow through  $H'_6$ ,  $q$ ,  $H'_7$ ,  $e_2$ ,  $H'_5$ ,  $p$ , and  $H'_9$ , until  $t$ , and consider different cases, depending on which of the subedgeworks  $H'_5$ ,  $H'_6$ ,  $H'_7$ , and  $H'_9$  has the minimum saturation rate.

- If  $\tau = r_9^s$ ,  $H'_9$  is saturated. We first assume that  $H'$  contains an  $s_1 - t_1$  path, and route (some of) the remaining flow (i) through  $H'_4$ ,  $H'_5$ , an  $s_1 - t_1$  path,  $H'_7$ , and  $H'_8$ , and (ii) through  $H'_6$ ,  $q$ ,  $H'_7$ , and  $H'_8$ . We do so until either at least one of the subedgeworks  $H'_7$  and  $H'_8$  or the subedgework  $H'_6$  and at least one of the subedgeworks  $H'_4$  and  $H'_5$  become saturated. Since  $\min\{r_7^s, r_8^s\} \leq r/3$ , this requires at most  $r/3 - \tau$  additional units of flow. If  $H'$  does not contain an  $s_1 - t_1$  path, we route the remaining flow only through route (ii), until either at least one of the subedgeworks  $H'_7$  and  $H'_8$  or the subedgework  $H'_6$  become saturated. In both cases, the newly saturated subedgeworks, together with the saturated subedgeworks  $H'_1$ ,  $H'_3$ , and  $H'_9$ , form an  $s - t$  cut of saturated subedgeworks, and thus the worst equilibrium bottleneck cost is at least  $r/(3\gamma_2)$ .
- If  $\tau = r_6^s$ ,  $H'_6$  is saturated. As before, we first assume that  $H'$  contains an  $s_1 - t_1$  path, and route the remaining flow (i) through  $H'_4$ ,  $H'_5$ ,  $p$ , and  $H'_9$ , and (ii) through  $H'_4$ ,  $H'_5$ , an  $s_1 - t_1$  path,  $H'_9$  and  $H'_8$ , until either at least one of the subedgeworks  $H'_4$  and  $H'_5$ , or the subedgework  $H'_9$  and at least one of the subedgeworks  $H'_7$  and  $H'_8$  become saturated. Since  $\min\{r_4^s, r_5^s\} \leq r/3$ , this requires at most  $r/3 - \tau$  additional units of flow. If  $H'$  does not contain an  $s_1 - t_1$  path, we route the remaining flow only through route (i), until either at least one of the subedgeworks  $H'_4$  and  $H'_5$  or the subedgework  $H'_9$  become saturated. In both cases, the newly saturated subedgeworks, together with the saturated subedgeworks  $H'_1$ ,  $H'_3$ , and  $H'_6$ , form an  $s - t$  cut of saturated subedgeworks, and thus the worst equilibrium bottleneck cost is at least  $r/(3\gamma_2)$ .
- If  $\tau = r_7^s$ ,  $H'_7$  is saturated. Then, we first assume that  $H'$  contains

an  $s_2 - t_2$  path, and route the remaining flow (i) through  $H'_4$ ,  $H'_5$ ,  $p$ , and  $H'_9$ , and (ii) through  $H'_6$ , an  $s_2 - t_2$  path, and  $H'_9$ , until either the subedgework  $H'_9$ , or the subedgework  $H'_6$  and at least one of the subedgeworks  $H'_4$  and  $H'_5$  become saturated. Since  $r_9^s \leq r/3$ , this requires at most  $r/3 - \tau$  additional units of flow. If  $H'$  does not contain an  $s_2 - t_2$  path, we route the remaining flow only through route (i), until either at least one of the subedgeworks  $H'_4$  and  $H'_5$  or the subedgework  $H'_9$  become saturated. In both cases, the newly saturated subedgeworks, together with the saturated subedgeworks  $H'_1$ ,  $H'_3$ , and  $H'_7$ , form an  $s - t$  cut of saturated subedgeworks, and thus the worst equilibrium bottleneck cost is at least  $r/(3\gamma_2)$ .

- If  $\tau = r_5^s$ ,  $H'_5$  is saturated. As before, we first assume that  $H'$  contains an  $s_2 - t_2$  path, and route the remaining flow (i) through  $H'_6$ ,  $q$ ,  $H'_7$ , and  $H'_8$ , and (ii) through  $H'_6$ , an  $s_2 - t_2$  path, and  $H'_9$ , until either the subedgework  $H'_6$ , or the subedgework  $H'_9$  and at least one of the subedgeworks  $H'_7$  and  $H'_8$  become saturated. Since  $r_6^s \leq r/3$ , this requires at most  $r/3 - \tau$  additional units of flow. If  $H'$  does not contain an  $s_2 - t_2$  path, we route the remaining flow only through route (i), until either at least one of the subedgeworks  $H'_7$  and  $H'_8$  or the subedgework  $H'_6$  become saturated. In both cases, the newly saturated subedgeworks, together with the saturated subedgeworks  $H'_1$ ,  $H'_3$ , and  $H'_5$ , form an  $s - t$  cut of saturated subedgeworks, and thus the worst equilibrium bottleneck cost is at least  $r/(3\gamma_2)$ .

Thus, in all cases, we obtain an equilibrium flow with a bottleneck cost of at least  $r/(3\gamma_2)$ . However, in the construction above, the route  $H'_6, q, H'_7, e_2, H'_5, p, H'_9$  may not be simple, since  $p$  and  $q$  may not be vertex-disjoint. If this is the case, this route is technically not allowed by our model, where the flow is only routed through simple  $s - t$  paths. Nevertheless, the corresponding edge flow can be decomposed into the following three simple routes: (i)  $H'_1, e_2$ , and  $H'_3$ , (ii)  $H'_1, e_2, H'_5, p$ , and  $H'_9$ , and (iii)  $H'_6, q, H'_7, e_2$ , and  $H'_3$ , unless  $\min\{r_1^s, r_3^s\} \leq r/3$ . Moreover, if  $\min\{r_1^s, r_3^s\} \leq r/3$ , we can work as above, and saturate both  $H'_1$  and  $H'_3$  with at most  $r/3$  units of flow. The remaining  $2r/3$  units of flow can be routed (i) through  $H'_6, q, H'_7$ , and  $H'_8$ , and (ii) through  $H'_4, H'_5, p$ , and  $H'_9$ , and possibly either through  $H'_6$ , an  $s_2 - t_2$  path<sup>1</sup>, and  $H'_9$ , or through  $H'_4, H'_5$ , an  $s_1 - t_1$  path,  $H'_7$ , and  $H'_8$ , until either  $H'_4$  (or  $H'_5$ ) and  $H'_6$ , or  $H'_7$  (or  $H'_8$ ) and  $H'_9$  are saturated. This routing only uses simple routes. In addition,

<sup>1</sup>We note that if the paths  $p$  and  $q$  are not vertex-disjoint, we also have an  $s_1 - t_1$  path and an  $s_2 - t_2$  path in  $H'$ .

these saturated subedgeworks, together with the saturated subedgeworks  $H'_1$  and  $H'_3$ , form an  $s-t$  cut of saturated subedgeworks, and thus the worst equilibrium bottleneck cost is at least  $r/(3\gamma_2)$ .  $\square$

Propositions 14 and 15 immediately imply part (3) of the lemma, which, in turn, implies part (2).  $\square$

Each time we apply Lemma 11.4 to a  $\gamma$ -gap instance  $G$ , we obtain a  $4\gamma/3$ -gap instance  $G'$  with a number of vertices of at most 8 times the vertices of  $G$  plus the number of vertices of  $D$ . Therefore, if we start with an instance  $\mathcal{I} = (D, s_1, s_2, t_1, t_2)$  of 2-DDP, where  $D$  has  $k$  vertices, and apply Lemma 11.1 once, and subsequently apply Lemma 11.4 for  $\lfloor \log_{4/3} k \rfloor$  times, we obtain a  $k$ -gap instance  $\mathcal{G}'$ , where the network  $G'$  has  $n = O(k^{8 \cdot 23})$  vertices. Suppose now that there is a polynomial-time algorithm  $A$  that approximates the best subnetwork of  $G'$  within a factor of  $O(k^{1-\varepsilon}) = O(n^{0.121-\varepsilon})$ , for some small  $\varepsilon > 0$ . Then, if  $\mathcal{I}$  is a YES-instance of 2-DDP, algorithm  $A$ , applied to  $G'$ , should return a best subnetwork  $H$  with at least one copy of a good subnetwork of  $D$ . Since  $H$  contains a polynomial number of copies of subnetworks of  $D$ , and we can check whether a subnetwork of  $D$  is good in polynomial time, we can efficiently recognize  $\mathcal{I}$  as a YES-instance of 2-DDP. On the other hand, if  $\mathcal{I}$  is a NO-instance of 2-DDP,  $D$  includes no good subnetworks. Again, we can efficiently check that in the subnetwork returned by algorithm  $A$ , there are not any copies of a good subnetwork of  $D$ , and hence recognize  $\mathcal{I}$  as a NO-instance of 2-DDP. Thus, we obtain that:

**Theorem 11.5.** For bottleneck routing games with strictly increasing linear latencies, it is NP-hard to approximate BSubNBC within a factor of  $O(n^{0.121-\varepsilon})$ , for any constant  $\varepsilon > 0$ .

**Remark 11.6.** If in the network  $G$  in the proof of Lemma 11.1 (fig. 11.1) we replace the cost functions  $x$  and  $x/2$  with  $x^d$  and  $x^d/2^d$  respectively, we will get an instance with  $\gamma_1 = 4^d$  and  $\gamma_2 = 3^d$ , and thus  $G$  would be a  $(4/3)^d$ -gap instance. Moreover, if we apply the same techniques as in lemma 11.4, we can amplify the inapproximability gap. As in Lemma 11.4 we inductively create a new network using as a base the base network of figure 11.1 with cost functions  $x^d$  instead of  $x$  and  $x^d/2^d$  instead of  $x/2$ . In the new network the edges  $e_4, \dots, e_9$  are replaced with a copy of the old network with the known gap  $(4/3)^d$ . Edges  $e_1, e_3$  are replaced with a copy of the old network but with all the cost functions divided by  $2^d$ . This will result to a graph that gives an inapproximability gap of  $(4/3)^{2^d}$ . Doing this  $t = \log_{(4/3)^d} n$  times, we result to a network with  $O(n^{\log_{(4/3)^d} 8^{t+1}})$  vertices

and an inapproximability gap of  $n$ . So, in a similar way like before, we get that (unless  $P=NP$ ), we cannot polynomially approximate BSubNBC within a factor of  $O(n^{1/(\log_{(4/3)^d} 8+1)} - \varepsilon)$

Using  $\alpha^x$  instead of  $x$  and  $\alpha^{x/2}$  instead of  $x/2$  and applying the same technique for say  $t$  times we get a network with gap  $B^*(\mathcal{G})^{(4/3)^t-1}$

## 11.5 Networks with Quasipolynomially Many Paths

In this section, we approximate, in quasipolynomial-time, the best subnetwork and its worst equilibrium bottleneck cost for instances  $\mathcal{G} = (G, c, r)$  where the network  $G$  has quasipolynomially many  $s - t$  paths, the latency functions are continuous and satisfy a Lipschitz condition, and the worst Nash flow in the best subnetwork routes a non-negligible amount of flow on all used edges.

We highlight that the restriction to networks with quasipolynomially many  $s - t$  paths is somehow necessary, in the sense that Theorem 11.5 shows that if the network has exponentially many  $s - t$  paths, as it happens for the hard instances of 2-DDP, and thus for the networks  $G$  and  $G'$  constructed in the proofs of Lemma 11.1 and Lemma 11.4, it is NP-hard to approximate BSubNBC within any reasonable factor. Also, we can always assume, without loss of generality, that the worst Nash flow of the best subnetwork  $H^*$  assigns positive flow to all edges of  $H^*$ . Otherwise, we can remove any unused edges, without increasing the worst equilibrium bottleneck cost of  $H^*$ . In addition, we assume here that there is a constant  $\delta > 0$ , such that the worst Nash flow in  $H^*$  routes more than  $\delta$  units of flow on all edges of the best subnetwork  $H^*$ .

In the following, we normalize the traffic rate  $r$  to 1. This is for convenience and can be made without loss of generality<sup>2</sup>. Our algorithm is based on [42, Lemma 2], which applies Althöfer's "Sparsification" Lemma [5] (similar technique in [60], independently), and shows that any flow can be approximated by a "sparse" flow using logarithmically many paths.

**Lemma 11.7.** Let  $\mathcal{G} = (G(V, E), c, 1)$  be a routing instance, and let  $f$  be any  $\mathcal{G}$ -feasible flow. Then, for any  $\varepsilon > 0$ , there exists a  $\mathcal{G}$ -feasible flow  $\tilde{f}$  using at most  $k(\varepsilon) = \lceil \log(2m)/(2\varepsilon^2) \rceil + 1$  paths, such that for all edges  $e$ ,  $|\tilde{f}_e - f_e| \leq \varepsilon$ , if  $f_e > 0$ , and  $\tilde{f}_e = 0$ , otherwise.

<sup>2</sup>Given a bottleneck routing game  $\mathcal{G}$  with traffic rate  $r > 0$ , we can replace each latency function  $d_e(x)$  with  $d_e(rx)$ , and obtain a bottleneck routing game  $\mathcal{G}'$  with traffic rate 1, and the same Nash flows, PoA, and solutions to BSubNBC.

By Lemma 11.7, there exists a sparse flow  $\tilde{f}$  that approximates the worst Nash flow  $f$  on the best subnetwork  $H^*$  of  $G$ . Moreover, the proof of [42, Lemma 2] shows that the flow  $\tilde{f}$  is determined by a multiset  $P$  of at most  $k(\varepsilon)$  paths, selected among the paths used by  $f$ . Then, for every path  $p \in \mathcal{P}$ ,  $\tilde{f}_p = |P(p)|/|P|$ , where  $|P(p)|$  is number of times the path  $p$  is included in the multiset  $P$ , and  $|P|$  is the cardinality of  $P$ . Therefore, if the total number  $|\mathcal{P}|$  of  $s-t$  paths in  $G$  is quasipolynomial, we can find, in quasipolynomial-time, by exhaustive search, a flow-subnetwork pair that approximates the optimal solution of BSubNBC. Based on this intuition, we next obtain an approximation algorithm for BSubNBC on networks with quasipolynomially many paths, under the assumption that there is a constant  $\delta > 0$ , such that the worst Nash flow in the best subnetwork  $H^*$  routes more than  $\delta$  units of flow on all edges of  $H^*$ . This assumption is necessary so that the exhaustive search on the family of sparse flows of Lemma 11.7 can generate the best subnetwork  $H^*$ , which is crucial for the analysis.

**Theorem 11.8.** Let  $\mathcal{G} = (G(V, E), c, 1)$  be a bottleneck routing game with continuous latency functions that satisfy the Lipschitz condition with a constant  $\xi > 0$ , let  $H^*$  be the best subnetwork of  $G$ , and let  $f^*$  be the worst Nash flow in  $H^*$ . If for all edges  $e$  of  $H^*$ ,  $f_e^* > \delta$ , for some constant  $\delta > 0$ , then for any constant  $\varepsilon > 0$ , we can compute in time  $|\mathcal{P}|^{O(\log(2m)/\min\{\delta^2, \varepsilon^2/\xi^2\})}$  a flow  $f$  and a subnetwork  $H$  such that: (i)  $f$  is an  $\varepsilon/2$ -Nash flow in the subnetwork  $H$ , (ii)  $B(f) \leq B(H^*, 1) + \varepsilon$ , (iii)  $B(H, 1) \leq B(f) + \varepsilon/4$ , and (iv)  $B(f) \leq B(H, 1) + \varepsilon/2$ .

*Proof.* Let  $\varepsilon > 0$  be a constant, and let  $\varepsilon_1 = \min\{\delta, \varepsilon/(4\xi)\}$ , and  $\varepsilon_2 = \varepsilon/2$ . We show that a flow-subnetwork pair  $(H, f)$  with the desired properties can be computed in time  $|\mathcal{P}|^{O(k(\varepsilon_1))}$ , where  $k(\varepsilon_1) = \lfloor \log(2m)/\min\{2\delta^2, \varepsilon^2/(8\xi^2)\} \rfloor + 1$ . For convenience, we say that a flow  $g$  is a *candidate flow* if there is a multiset  $P$  of paths from  $\mathcal{P}$ , with  $|P| \leq k(\varepsilon_1)$ , such that  $g_p = |P(p)|/|P|$ , for each  $p \in \mathcal{P}$ . Namely, a candidate flow belongs to the family of sparse flows, which by Lemma 11.7, can approximate any other flow. Similarly, a subnetwork  $H$  is a *candidate subnetwork* if there is a candidate flow  $g$  such that  $H$  consists of the edges used by  $g$  (and only of them), and a subnetwork-flow pair  $(H, g)$  is a *candidate solution*, if  $g$  is a candidate flow,  $H$  is a candidate subnetwork that includes all the edges used by  $g$  (and possibly some other edges), and  $g$  is an  $\varepsilon_2$ -Nash flow in  $H$ .

By exhaustive search, in time  $|\mathcal{P}|^{O(k(\varepsilon_1))}$ , we generate all candidate flows, all candidate subnetworks, and compute the bottleneck cost  $B(g)$  of any candidate flow  $g$ . Then, for each pair  $(H, g)$ , where  $g$  is a candidate flow and  $H$  is a candidate subnetwork, we check, in polynomial time, whether  $g$  is an  $\varepsilon_2$ -Nash flow in  $H$ , and thus whether  $(H, g)$  is a candidate solution. Thus,

in time  $|\mathcal{P}|^{O(k(\epsilon_1))}$ , we determine all candidate solutions. For each candidate subnetwork  $H$  that participates in at least one candidate solution, we let  $\tilde{B}(H)$  be the maximum bottleneck cost  $B(g)$  of a candidate flow  $g$  for which  $(H, g)$  is a candidate solution. The algorithm returns the subnetwork  $H$  that minimizes  $\tilde{B}(H)$ , and a flow  $f$  for which  $(H, f)$  is a candidate solution and  $\tilde{B}(H) = B(f)$ .

The exhaustive search above can be implemented in  $|\mathcal{P}|^{O(k(\epsilon_1))}$  time. As for the properties of the solution  $(H, f)$ , the definition of candidate solutions immediately implies (i), i.e., that  $f$  is an  $\epsilon/2$ -Nash flow in  $H$ .

In the following we use Lemma 11.7, and show (ii), (iii), and (iv).

We first show (ii), i.e., that  $B(f) \leq B(H^*, 1) + \epsilon$ . We recall that  $H^*$  denotes the best subnetwork of  $\mathcal{G}$  and  $f^*$  denotes the worst Nash flow in  $H^*$ . Also, by hypothesis,  $f_e^* > \delta > 0$ , for all edges  $e$  of  $H^*$ .

By Lemma 11.7, there is a candidate flow  $\tilde{f}$  such that for all edges  $e$  of  $H^*$ ,  $|\tilde{f}_e - f_e^*| \leq \epsilon_1$ . Thus, since  $\epsilon_1 \leq \delta$ ,  $H^*$  is a candidate network, because  $\tilde{f}_e > 0$  for all edges  $e$  of  $H^*$ . Moreover, by the Lipschitz condition and the choice of  $\epsilon_1$ , for all edges  $e$  of  $H^*$ ,  $|d_e(\tilde{f}_e) - d_e(f_e^*)| \leq \epsilon/4$ . Therefore, since  $f^*$  is a Nash flow in  $H^*$ ,  $\tilde{f}$  is an  $\epsilon_2$ -Nash flow in  $H^*$ , and thus  $(H, \tilde{f})$  is a candidate solution. Furthermore,  $|B(\tilde{f}) - B(f^*)| \leq \epsilon/4$ , i.e., the bottleneck cost of  $\tilde{f}$  is within an additive term of  $\epsilon/4$  from the worst equilibrium bottleneck cost of  $H^*$ . In particular,  $B(\tilde{f}) \leq B(H^*, 1) + \epsilon/4$ .

We also need to show that for any other candidate flow  $g$  for which  $(H^*, g)$  is a candidate solution,  $B(g) \leq B(\tilde{f}) + 3\epsilon/4$ , and thus  $\tilde{B}(H^*) \leq B(\tilde{f}) + 3\epsilon/4 \leq B(H^*, 1) + \epsilon$ . To reach a contradiction, let us assume that there is a candidate flow  $g$  that is an  $\epsilon_2$ -Nash flow in  $H^*$  and has  $B(g) > B(\tilde{f}) + 3\epsilon/4$ . But then, we should expect that there is a Nash flow  $g'$  in  $H^*$  that closely approximates  $g$  and has a bottleneck cost of  $B(g') \approx B(g) > B(\tilde{f}) + 3\epsilon/4$ , a contradiction. Formally, since  $g$  is an  $\epsilon_2$ -Nash flow in  $H^*$ , the set of edges with  $d_e(g_e) \geq B(g) - \epsilon/2$  comprises an  $s - t$  cut in  $H^*$ . Then, by the continuity of the latency functions, we can fix a part of the flow routed essentially as in  $g$ , so that there is an  $s - t$  cut consisting of used edges with latency  $B(g) - \epsilon/2$ , and possibly unused edges with latency at least  $B(g) - \epsilon/2$ , and reroute the remaining flow on top of it, so that we obtain a Nash flow  $g'$  in  $H^*$ . But then,

$$B(g') \geq B(g) - \epsilon/2 > B(\tilde{f}) + \epsilon/4 \geq B(f^*),$$

which contradicts the hypothesis that  $f^*$  is the worst Nash flow in  $H^*$ .

Therefore,  $\tilde{B}(H^*) \leq B(H^*, 1) + \epsilon$ . Since the algorithm returns the candidate solution  $(H, f)$ , and not a candidate solution including  $H^*$ ,  $\tilde{B}(H) \leq B(H^*)$ . Thus, we obtain (ii), namely that  $\tilde{B}(H) = B(f) \leq B(H^*, 1) + \epsilon$ .

We proceed to show (iii), namely that  $B(H, 1) \leq B(f) + \varepsilon/4$ . To this end, we let  $g$  be the worst Nash flow in  $H$ . By Lemma 11.7, there is a candidate flow  $\tilde{g}$  such that for all edges  $e$  of  $H$ ,  $|\tilde{g}_e - g_e| \leq \varepsilon_1$ , if  $g_e > 0$ , and  $\tilde{g}_e = 0$ , otherwise. Therefore, by the Lipschitz condition and the choice of  $\varepsilon_1$ , for all edges  $e$  of  $H$ ,  $|d_e(\tilde{g}_e) - d_e(g_e)| \leq \varepsilon/4$ , if  $g_e > 0$ , and  $d_e(\tilde{g}_e) = d_e(g_e) = 0$ , otherwise. This implies that  $|B(\tilde{g}) - B(g)| \leq \varepsilon/4$ , i.e., that bottleneck cost of  $\tilde{g}$  is within an additive term of  $\varepsilon/4$  from the bottleneck cost of  $g$ . In particular,  $B(g) \leq B(\tilde{g}) + \varepsilon/4$ .

We also need to show that  $(H, \tilde{g})$  is a candidate solution. Since  $H$  is a candidate subnetwork and  $\tilde{g}$  is a candidate flow, we only need to show that  $\tilde{g}$  is an  $\varepsilon_2$ -Nash flow in  $H$ . Since  $g$  is a Nash flow in  $H$ , the set of edges  $C = \{e : d_e(g_e) \geq B(g)\}$  comprises an  $s - t$  cut in  $H$ . In fact, for all edges  $e \in C$ ,  $d_e(g_e) = B(g)$ , if  $g_e > 0$ , and  $d_e(g_e) \geq B(g)$ , otherwise. Let us now consider the latency in  $\tilde{g}$  of each edge  $e \in C$ . If  $g_e = 0$ , then  $d_e(\tilde{g}_e) = d_e(g_e) \geq B(g) \geq B(\tilde{g}) - \varepsilon/4$ . If  $g_e > 0$ , then

$$B(\tilde{g}) \geq d_e(\tilde{g}_e) \geq d_e(g_e) - \varepsilon/4 = B(g) - \varepsilon/4 \geq B(\tilde{g}) - \varepsilon/2.$$

Therefore, for the flow  $\tilde{g}$ , we have an  $s - t$  cut in  $H$  consisting of edges  $e$  either with  $\tilde{g}_e > 0$  and  $B(\tilde{g}) - \varepsilon/2 \leq d_e(\tilde{g}_e) \leq B(\tilde{g})$ , or with  $\tilde{g}_e = 0$  and  $d_e(\tilde{g}_e) \geq B(\tilde{g}) - \varepsilon/4$ . By the standard properties of  $\varepsilon$ -Nash flows (see also in Section 11.1), we obtain that  $\tilde{g}$  is a  $\varepsilon_2$ -Nash flow in  $H$ .

Hence, we have shown that  $(H, \tilde{g})$  is a candidate solution, and that  $B(g) \leq B(\tilde{g}) + \varepsilon/4$ . Therefore, the algorithm considers both candidate solutions  $(H, f)$  and  $(H, \tilde{g})$ , and returns  $(H, f)$ , which implies that  $B(\tilde{g}) \leq B(f)$ . Thus, we obtain (iii), namely that  $B(H, 1) = B(g) \leq B(f) + \varepsilon/4$ .

To conclude the proof, we next show (iv), namely that  $B(f) \leq B(H, 1) + \varepsilon/2$ . For the proof, we use the same notation as in (iii). The argument is essentially identical to that used in the second part of the proof of (ii). More specifically, to reach a contradiction, we assume that the candidate flow  $f$ , which is an  $\varepsilon_2$ -Nash flow in  $H$ , has  $B(f) > B(H, 1) + \varepsilon/2$ . Then, as before, we should expect that there is a Nash flow  $f'$  in  $H$  that approximates  $f$  and has a bottleneck cost of  $B(f') \approx B(f) > B(H, 1)$ , a contradiction. Formally, since  $f$  is an  $\varepsilon_2$ -Nash flow in  $H$ , the set of edges with  $d_e(f_e) \geq B(f) - \varepsilon/2$  comprises an  $s - t$  cut in  $H$ . Then, by the continuity of the latency functions, we can fix a part of the flow routed essentially as in  $f$ , so that there is an  $s - t$  cut consisting of used edges with latency  $B(f) - \varepsilon/2$ , and possibly unused edges with latency at least  $B(f) - \varepsilon/2$ , and reroute the remaining flow on top of it, so that we obtain a Nash flow  $f'$  in  $H$ . But then,  $B(f') \geq B(f) - \varepsilon/2 > B(H, 1)$ , which contradicts the definition of the worst equilibrium bottleneck cost  $B(H, 1)$  of  $H$ . Thus, we obtain (iv), namely that  $B(f) \leq B(H, 1) + \varepsilon/2$ .  $\square$

Therefore, the algorithm of Theorem 12.1 returns a flow-subnetwork pair  $(H, f)$  such that  $f$  is an  $\varepsilon/2$ -Nash flow in  $H$ , the worst equilibrium bottleneck cost of the subnetwork  $H$  approximates the worst equilibrium bottleneck cost of  $H^*$ , since  $B(H^*, 1) \leq B(H, 1) \leq B(H^*, 1) + 5\varepsilon/4$ , by (ii) and (iii), and the bottleneck cost of  $f$  approximates the worst equilibrium bottleneck cost of  $H$ , since  $B(H, 1) - \varepsilon/4 \leq B(f) \leq B(H, 1) + \varepsilon/2$ , by (iii) and (iv).



# Chapter 12

## Resolving Braess's Paradox in Random Networks

In this chapter, we study the approximability of the best subnetwork problem for the class of random Erdős-Rényi  $\mathcal{G}_{n,p}$  instances proven prone to Braess's paradox by (Roughgarden and Valiant, RSA 2010) and (Chung and Young, WINE 2010). Our main contribution is a polynomial-time approximation-preserving reduction of the best subnetwork problem for such instances to the corresponding problem in a simplified network where all neighbors of  $s$  and  $t$  are directly connected by 0 latency edges. Building on this, we obtain an approximation scheme that for any constant  $\varepsilon > 0$  and with high probability, computes a subnetwork and an  $\varepsilon$ -Nash flow with maximum latency at most  $(1 + \varepsilon)L^* + \varepsilon$ , where  $L^*$  is the equilibrium latency of the best subnetwork. Our approximation scheme runs in polynomial time if the random network has average degree  $O(\text{poly}(\ln n))$  and the traffic rate is  $O(\text{poly}(\ln \ln n))$ , and in quasipolynomial time for average degrees up to  $o(n)$  and traffic rates of  $O(\text{poly}(\ln n))$ .

### 12.1 Problem-Specific Definitions

We deal with a typical instance  $(G(V, E), (d_e)_{e \in E}, r)$  of a non atomic CG (*selfish routing game*). In such instances, as noted earlier, all used paths under a Nash flow have a unique minimum latency which we denote as  $L(G, d, r)$  or  $L(G, r)$ , for brevity, assuming that the latency function are given within  $G$ .

The paradox seems not an artifact of optimization theory [56, 77], and our motivation is whether in some practically interesting settings, where the paradox occurs, we can efficiently compute a set of edges whose re-

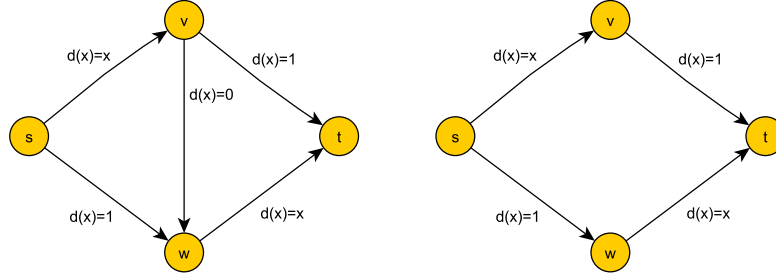

**Figure 12.1:**

(a) The optimal total latency social cost is  $3/2$ , achieved by routing half of the flow on each of the paths  $(s, v, t)$  and  $(s, w, t)$ . In the Nash flow, all traffic goes through the path  $(s, v, w, t)$  and has selfish cost 2, thus inducing the *worst* PoA =  $4/3$  for linear latencies. (b) If we remove the edge  $(v, w)$ , the Nash flow coincides with the optimal social flow. Hence the network (b) is the *best subnetwork* of network (a) and achieves the *best possible* PoA = 1, with no sacrificed players through slower paths.

removal significantly improves the equilibrium latency.

We only consider linear latencies  $d_e(x) = a_e x + b_e$ , with  $a_e, b_e \geq 0$ . We restrict our attention to instances where the coefficients  $a_e$  and  $b_e$  are randomly selected from a pair of random variables  $\mathcal{A}$  and  $\mathcal{B}$ . Following [24, 84], we say that  $\mathcal{A}$  and  $\mathcal{B}$  are *reasonable* if:

- $\mathcal{A}$  has bounded range  $[A_{\min}, A_{\max}]$  and  $\mathcal{B}$  has bounded range  $[0, B_{\max}]$ , where  $A_{\min} > 0$  and  $A_{\max}, B_{\max}$  are constants, i.e., they do not depend on  $r$  and  $|V|$ .
- There is a closed interval  $I_{\mathcal{A}}$  of positive length, such that for every non-trivial subinterval  $I' \subseteq I_{\mathcal{A}}$ ,  $\Pr[\mathcal{A} \in I'] > 0$ .
- There is a closed interval  $I_{\mathcal{B}}$ ,  $0 \in I_{\mathcal{B}}$ , of positive length, such that for every non-trivial subinterval  $I' \subseteq I_{\mathcal{B}}$ ,  $\Pr[\mathcal{B} \in I'] > 0$ . Moreover, for any constant  $\eta > 0$ , there exists a constant  $\delta_{\eta} > 0$ , such that  $\Pr[\mathcal{B} \leq \eta] \geq \delta_{\eta}$ .

**Flows and Nash Flows.** Two flows  $f$  and  $g$  are *different* if there is an edge  $e$  with  $f_e \neq g_e$ .

Given a flow  $f$ , let the latency of  $f$  be  $L(f) = \max_{p:f_p>0} d_p(f)$ . We sometimes write  $L_G(f)$  when the network  $G$  is not clear from the context.

For an instance  $(G(V, E), r)$  and a flow  $f$ , we let  $E_f = \{e \in E : f_e > 0\}$  be the set of edges used by  $f$ , and  $G_f(V, E_f)$  be the corresponding subnetwork of  $G$ . In a Nash flow  $f$ , all players incur a common latency on their

paths, which, according to the previous definitions, is  $L(f) = \min_p d_p(f) = \max_{p: f_p > 0} d_p(f)$ . A Nash flow  $f$  on a network  $G(V, E)$  is a Nash flow on any subnetwork  $G'(V', E')$  of  $G$  with  $E_f \subseteq E'$ .

Every instance  $(G, r)$  admits at least one Nash flow, and the players' latency is the same for all Nash flows (see e.g., [77]). For linear latency functions, a Nash flow can be computed efficiently, in strongly polynomial time, while for strictly increasing latencies, the Nash flow is essentially unique (see e.g., [77]).

**Best Subnetwork.** Recall, the *best subnetwork*  $H^*$  of  $(G, r)$  is a subnetwork of  $G$  with the minimum equilibrium latency, i.e.,  $H^*$  has  $L(H^*, r) \leq L(H, r)$  for any subnetwork  $H$  of  $G$ . We study the approximability of the *Best Subnetwork Equilibrium Latency* problem, or BestSubEL in short. In BestSubEL, we are given an instance  $(G, r)$ , and seek for the best subnetwork  $H^*$  of  $(G, r)$  and its equilibrium latency  $L(H^*, r)$ .

**Good Networks.** We restrict our attention to undirected  $s - t$  networks  $G(V, E)$ . We let  $n \equiv |V|$  and  $m \equiv |E|$ . For any vertex  $v$ , we let  $\Gamma(v) = \{u \in V : \{u, v\} \in E\}$  denote the set of  $v$ 's neighbors in  $G$ . Similarly, for any non-empty  $S \subseteq V$ , we let  $\Gamma(S) = \bigcup_{v \in S} \Gamma(v)$  denote the set of neighbors of the vertices in  $S$ , and let  $G[S]$  denote the subnetwork of  $G$  induced by  $S$ . For convenience, we let  $V_s \equiv \Gamma(s)$ ,  $E_s \equiv \{\{s, u\} : u \in V_s\}$ ,  $V_t \equiv \Gamma(t)$ ,  $E_t \equiv \{\{v, t\} : v \in V_t\}$ , and  $V_m \equiv V \setminus (\{s, t\} \cup V_s \cup V_t)$ . We also let  $n_s = |V_s|$ ,  $n_t = |V_t|$ ,  $n_+ = \max\{n_s, n_t\}$ ,  $n_- = \min\{n_s, n_t\}$ , and  $n_m = |V_m|$ . We sometimes write  $V(G)$ ,  $n(G)$ ,  $V_s(G)$ ,  $n_s(G)$ ,  $\dots$ , if  $G$  is not clear from the context.

It is convenient to think that the network  $G$  has a layered structure consisting of  $s$ , the set of  $s$ 's neighbors  $V_s$ , an "intermediate" subnetwork connecting the neighbors of  $s$  to the neighbors of  $t$ , the set of  $t$ 's neighbors  $V_t$ , and  $t$ . Then, any  $s - t$  path starts at  $s$ , visits some  $u \in V_s$ , proceeds either directly or through some vertices of  $V_m$  to some  $v \in V_t$ , and finally reaches  $t$ . Thus, we refer to  $G_m \equiv G[V_s \cup V_m \cup V_t]$  as the *intermediate subnetwork* of  $G$ . Depending on the structure of  $G_m$ , we say that:

- $G$  is a *random*  $\mathcal{G}_{n,p}$  network if (i)  $n_s$  and  $n_t$  follow the binomial distribution with parameters  $n$  and  $p$ , and (ii) if any edge  $\{u, v\}$ , with  $u \in V_m \cup V_s$  and  $v \in V_m \cup V_t$ , exists independently with probability  $p$ . Namely, the intermediate network  $G_m$  is an Erdős-Rényi random graph with  $n - 2$  vertices and edge probability  $p$ , except for the fact that there are no edges in  $G[V_s]$  and in  $G[V_t]$ .
- $G$  is *internally bipartite* if the intermediate network  $G_m$  is a bipartite graph with independent sets  $V_s$  and  $V_t$ .  $G$  is *internally complete bipartite* if every neighbor of  $s$  is directly connected by an edge to every

neighbor of  $t$ .

- $G$  is *0-latency simplified* if it is internally complete bipartite and every edge  $e$  connecting a neighbor of  $s$  to a neighbor of  $t$  has latency function  $d_e(x) = 0$ .

The *0-latency simplification*  $G_0$  of a given network  $G$  is a 0-latency simplified network obtained from  $G$  by replacing  $G[V_m]$  with a set of 0-latency edges directly connecting every neighbor of  $s$  to every neighbor of  $t$ . Moreover, we say that a 0-latency simplified network  $G$  is *balanced*, if  $|n_s - n_t| \leq 2n$ .

We say that a network  $G(V, E)$  is  $(n, p, k)$ -good, for some integer  $n \leq |V|$ , some probability  $p \in (0, 1)$ , with  $pn = o(n)$ , and some constant  $k \geq 1$ , if  $G$  satisfies that:

1. The maximum degree of  $G$  is at most  $3np/2$ , i.e., for any  $v \in V$ ,  $|\Gamma(v)| \leq 3np/2$ .
2.  $G$  is an *expander graph*, namely, for any set  $S \subseteq V$ ,  $|\Gamma(S)| \geq \min\{np|S|, n\}/2$ .
3. The edges of  $G$  have random reasonable latency functions distributed according to  $\mathcal{A} \times \mathcal{B}$ , and for any constant  $\eta > 0$ ,  $\Pr[\mathcal{B} \leq \eta/\ln n]np = \omega(1)$ .
4. If  $k > 1$  and we randomly partition  $V_m$  into  $k$  sets  $V_m^1, \dots, V_m^k$ , each of cardinality  $|V_m|/k$ , all the induced subnetworks  $G[\{s, t\} \cup V_s \cup V_m^i \cup V_t]$  are  $(n/k, p, 1)$ -good, with a possible violation of the maximum degree bound by  $s$  and  $t$ .

If  $G$  is a *random*  $\mathcal{G}_{n,p}$  network, with  $n$  sufficiently large and  $p \geq ck \ln n/n$ , for some large enough constant  $c > 1$ , then  $G$  is a  $(n, p, k)$ -good network with high probability (see e.g., [15]), provided that the latency functions satisfy condition (3) above. Similarly, the random instances considered in [24] are good with high probability. Also note that the 0-latency simplification of a good network is balanced, due to (1) and (2).

## 12.2 The Approximation Scheme and Outline of the Analysis

In this section, we describe the main steps of the approximation scheme (see also Algorithm 1), and give an outline of its analysis. We let  $\varepsilon > 0$  be

**Algorithm 2:** Approximation Scheme for BestSubEL in Good Networks

**Input:** Good network  $G(V, E)$ , rate  $r > 0$ , approximation guarantee  $\varepsilon > 0$

**Output:** Subnetwork  $H$  of  $G$  and  $\varepsilon$ -Nash flow  $g$  in  $H$  with  $L(g) \leq (1 + \varepsilon)L(H^*, r) + \varepsilon$

- 1 if  $L(G, r) < \varepsilon$ , return  $G$  and a Nash flow of  $(G, r)$  ;
- 2 create the 0-latency simplification  $G_0$  of  $G$  ;
- 3 if  $r \geq (B_{\max} n_+) / (\varepsilon A_{\min})$ , then let  $H_0 = G_0$  and let  $f$  be a Nash flow of  $(G_0, r)$  ;
- 4 else, let  $H_0$  be the subnetwork and  $f$  the  $\varepsilon/6$ -Nash flow of Thm. 12.7 applied with error  $\varepsilon/6$  ;
- 5 let  $H$  be the subnetwork and let  $g$  be the  $\varepsilon$ -Nash flow of Lemma 12.9 starting from  $H_0$  and  $f$  ;
- 6 return the subnetwork  $H$  and the  $\varepsilon$ -Nash flow  $g$  ;

the approximation guarantee, and assume that  $L(G, r) \geq \varepsilon$ . Otherwise, any Nash flow of  $(G, r)$  suffices.

Algorithm 1 is based on an approximation-preserving reduction of BestSubEL for a good network  $G$  to BestSubEL for the 0-latency simplification  $G_0$  of  $G$ . The first step of our approximation-preserving reduction is to show that the equilibrium latency of the best subnetwork does not increase when we consider the 0-latency simplification  $G_0$  of a network  $G$  instead of  $G$  itself. Since decreasing the edge latencies (e.g., decreasing  $d_{(v,w)}(x) = 1$  to  $d_{(v,w)}(x) = 0$  in Fig. 12.1.a) may trigger Braess's paradox, we need Lemma 12.2 and its careful proof to make sure that zeroing out the latency of the intermediate subnetwork does not cause an abrupt increase in the equilibrium latency.

Next, we focus on the 0-latency simplification  $G_0$  of  $G$  (step 2 in Alg. 1). We show that if the traffic rate is large enough, i.e., if  $r = \Omega(n_+/\varepsilon)$ , the paradox has a marginal influence on the equilibrium latency. Thus, any Nash flow of  $(G_0, r)$  is an  $(1 + \varepsilon)$ -approximation of BestSubEL (Lemma 12.3, step 4). If  $r = O(n_+/\varepsilon)$ , we use an approximate version of Caratheodory's theorem (Theorem 12.6) to prove that by an efficient exhaustive search we can obtain an  $\varepsilon/6$ -approximation of BestSubEL for  $(G_0, r)$  (Theorem 12.7, step 4), which in fact we obtain!

We now have a subnetwork  $H_0$  and an  $\varepsilon/6$ -Nash flow  $f$  that comprise a good approximate solution to BestSubEL for the simplified instance  $(G_0, r)$ . The next step of our approximation-preserving reduction is to extend  $f$  to an approximate solution to BestSubEL for the original instance  $(G, r)$ . The

intuition is that due to the expansion and the reasonable latencies of  $G$ , any collection of 0-latency edges of  $H_0$  used by  $f$  to route flow from  $V_s$  to  $V_t$  can be “simulated” by an appropriate collection of low-latency paths of the intermediate subnetwork  $G_m$  of  $G$ . We first prove this claim for a small part of  $H_0$  consisting only of neighbors of  $s$  and neighbors of  $t$  with approximately the same latency under  $f$  (Lemma 12.8, the proof draws ideas from [24, Lemma 5]). Then, using a careful latency-based grouping of the neighbors of  $s$  and of the neighbors of  $t$  in  $H_0$ , we extend this claim to the entire  $H_0$  (Lemma 12.9). Thus, we obtain a subnetwork  $H$  of  $G$  and an  $\varepsilon$ -Nash flow  $g$  in  $H$  such that  $L(g) \leq (1 + \varepsilon)L(H^*, r) + \varepsilon$  (step 5).

We summarize our main result. The proof follows by combining Lemma 12.2, Theorem 12.7, and Lemma 12.9 in the way indicated by Algorithm 1 and the discussion above.

**Theorem 12.1.** Let  $G(V, E)$  be  $(n, p, k)$ -good network, where  $k \geq 1$  is a large enough constant, let  $r > 0$  be any traffic rate, and let  $H^*$  be the best subnetwork of  $(G, r)$ . Then, for any  $\varepsilon > 0$ , Algorithm 1 computes in time  $n_+^{O(r^2 A_{\max}^2 / \varepsilon^2)} \text{poly}(|V|)$ , a flow  $g$  and a subnetwork  $H$  of  $G$  such that with high probability, wrt. the random choice of the latency functions,  $g$  is an  $\varepsilon$ -Nash flow of  $(H, r)$  and has  $L(g) \leq (1 + \varepsilon)L(H^*) + \varepsilon$ .

By the definition of reasonable latencies,  $A_{\max}$  is a constant. Also, by Lemma 12.3,  $r$  affects the running time only if  $r = O(n_+ / \varepsilon)$ . In fact, previous work on selfish network design assumes that  $r = O(1)$ , see e.g., [77]. Thus, if  $r = O(1)$  (or more generally, if  $r = O(\text{poly}(\ln \ln n))$ ) and  $pn = O(\text{poly}(\ln n))$ , in which case  $n_+ = O(\text{poly}(\ln n))$ , Theorem 12.1 gives a randomized polynomial-time approximation scheme for BestSubEL in good networks. Moreover, the running time is quasipolynomial for traffic rates up to  $O(\text{poly}(\ln n))$  and average degrees up to  $o(n)$ , i.e., for the entire range of  $p$  in [24, 84]. The next sections are devoted to the proofs of Lemmas 12.2 and 12.9, and of Theorem 12.7.

## 12.3 Network Simplification

We first show that the equilibrium latency of the best subnetwork does not increase when we consider the 0-latency simplification  $G_0$  of a network  $G$  instead of  $G$  itself.

**Lemma 12.2.** Let  $G$  be any network, let  $r > 0$  be any traffic rate, and let  $H$  be the best subnetwork of  $(G, r)$ . Then, there is a subnetwork  $H'$  of the 0-latency simplification of  $H$  (and thus, a subnetwork of  $G_0$ ) with  $L(H', r) \leq L(H, r)$ .

*Proof.* Throughout the proof, we assume wlog. that all the edges of  $H$  are used by the equilibrium flow  $f$  of  $(H, r)$  (otherwise, we can remove all unused edges from  $H$ ). The proof is constructive, and at the conceptual level, proceeds in two steps.

For the first step, given the equilibrium flow  $f$  of the best subnetwork  $H$  of  $G$ , we construct a simplification  $H_1$  of  $H$  that is internally bipartite and has constant latency edges connecting  $\Gamma(s)$  to  $\Gamma(t)$ .  $H_1$  also admits  $f$  as an equilibrium flow, and thus  $L(H_1, r) = L(H, r)$ . We also show how to further simplify  $H_1$  so that its intermediate bipartite subnetwork becomes acyclic.

To construct the simplification  $H_1$  of  $H$ , we let  $f$  be the equilibrium flow of  $H$ , and let  $L \equiv L(H, r)$ . For each  $u_i \in \Gamma(s)$  and  $v_j \in \Gamma(t)$ , we let  $f_{ij} = \sum_{p=(s, u_i, \dots, v_j, t)} f_p$  be the flow routed by  $f$  from  $u_i$  to  $v_j$ . The network  $H_1$  is obtained from  $H$  by replacing the intermediate subnetwork of  $H$  with a bipartite subnetwork connecting  $\Gamma(s)$  and  $\Gamma(t)$  with constant latency edges. More specifically, instead of the intermediate subnetwork of  $H$ , for each  $u_i \in \Gamma(s)$  and  $v_j \in \Gamma(t)$  with  $f_{ij} > 0$ , we have an edge  $\{u_i, v_j\}$  of constant latency  $b_{ij} = L - (a_{\{s, u_i\}} f_{\{s, u_i\}} + b_{\{s, u_i\}}) - (a_{\{v_j, t\}} f_{\{v_j, t\}} + b_{\{v_j, t\}})$  (the corresponding  $a_{ij}$  is set to 0). If  $f_{ij} = 0$ ,  $u_i$  and  $v_j$  are not connected in  $H_1$ . We note that by construction,  $H_1$  admits  $f$  as an equilibrium flow, and thus  $L(H_1, r) = L$ .

Furthermore, we modify  $H_1$  by deleting some edges from its intermediate subnetwork so that the induced bipartite subgraph  $H_1[\Gamma(s) \cup \Gamma(t)]$  becomes acyclic. Therefore, in the resulting network, for each  $u_i \in \Gamma(s)$  and each  $v_j \in \Gamma(t)$ , there is at most one  $(s, u_i, v_j, t)$  path in  $H_1$ . Hence, the resulting network admits a unique equilibrium flow with a unique path decomposition.

To this end, let us assume that there is a cycle  $C = (u_1, v_2, u_2, \dots, v_k, u_k, v_1, u_1)$  in the intermediate subnetwork  $H_1[\Gamma(s) \cup \Gamma(t)]$ . We let  $e_{k1} = \{u_k, v_1\}$  be the edge of  $C$  with the minimum amount of flow in  $f$ , and let  $f_{k1}$  be the flow through  $e_{k1}$  (see also Fig. 12.2). Then, removing  $e_{k1}$ , and updating the flows along the remaining edges of  $C$  so that  $f'_{ii} = f_{ii} + f_{k1}$ ,  $1 \leq i \leq k$ , and  $f'_{i(i+1)} = f_{i(i+1)} - f_{k1}$ ,  $1 \leq i \leq k-1$ , we “break” the cycle  $C$ , by eliminating the flow in  $e_{k1}$ , and obtain a new equilibrium flow  $f'$  of the same rate  $r$  and with the same latency  $L$  as that of  $f$ . Applying this procedure repeatedly to all cycles, we end up with an internally bipartite network  $H_1$  with an acyclic intermediate subnetwork that includes constant latency edges only. Moreover,  $H_1$  admits an equilibrium flow  $f$  of latency  $L$ . This concludes the first part of the proof.

The second part of the proof is to show that we can either remove some of the intermediate edges of  $H_1$  or zero their latencies, and obtain a subnetwork  $H'$  of the 0-latency simplification of  $H$  with  $L(H', r) \leq L(H, r)$ . To this end, we describe a procedure where in each step, we either remove

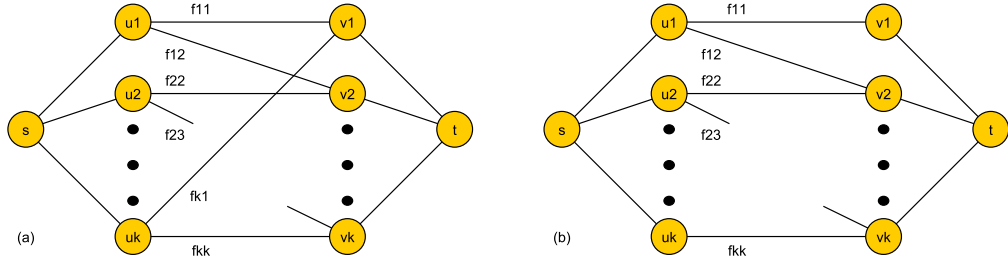

**Figure 12.2:** In (a), we have a cycle  $C = (u_1, v_2, u_2, \dots, v_k, u_k, v_1, u_1)$  in the intermediate subnetwork  $H_1[\Gamma(s) \cup \Gamma(t)]$ . We assume that  $f_{k1}$  is the minimum amount of flow through an edge of  $C$  in the equilibrium flow  $f$ . In (b), we have removed the edge  $e_{k1}$ , and show the corresponding change in the amount of flow on the remaining edges of  $C$ . Since the latency functions of the edges in  $C$  are constant, the change in the flow does not affect equilibrium.

some intermediate edge of  $H_1$  or zero its latency, without increasing the latency of the equilibrium flow.

Let us focus on an edge  $e_{kl} = \{u_k, v_l\}$  with  $b_{kl} > 0$ , and attempt to set its latency function to  $b'_{kl} = 0$ . We have also to change the equilibrium flow  $f$  to a new flow  $f'$  that is an equilibrium flow of latency at most  $L$  in the modified network with  $b'_{kl} = 0$ . We let  $r_p$  be the amount of flow moving from an  $s - t$  path  $p = (s, u_i, v_j, t)$  to the path  $p_{kl} = (s, u_k, v_l, t)$  during this change. We note that  $r_p$  may be negative, in which case,  $|r_p|$  units of flow actually move from  $p_{kl}$  to  $p$ . Thus,  $r_p$ 's define a rerouting of  $f$  to a new flow  $f'$ , with  $f'_p = f_p - r_p$ , for any  $s - t$  path  $p$  other than  $p_{kl}$ , and  $f'_{kl} = f_{kl} + \sum_p r_p$ .

Next, we show how to compute  $r_p$ 's so that  $f'$  is an equilibrium flow of cost at most  $L$  in the modified network (where we want to set  $b'_{kl} = 0$ ). We let  $\mathcal{P} = \mathcal{P}_{H_1} \setminus \{p_{kl}\}$  denote the set of all  $s - t$  paths in  $H_1$  other than  $p_{kl}$ . We let  $\bar{F}$  be the  $|\mathcal{P}| \times |\mathcal{P}|$  matrix, indexed by the paths  $p \in \mathcal{P}$ , where  $\bar{F}[p_1, p_2] = \sum_{e \in p_1 \cap p_2} a_e - \sum_{e \in p_1 \cap p_{kl}} a_e$ , and let  $\bar{r}$  be the vector of  $r_p$ 's. Then, the  $p$ -th component of  $\bar{F}\bar{r}$  is equal to  $d_p(f) - d_p(f')$ . In the following, we consider two cases depending on whether  $\bar{F}$  is singular or not.

If  $\bar{F}$  is non-singular, the linear system  $\bar{F}\bar{r} = \varepsilon \bar{1}$  has a unique solution  $\bar{r}_\varepsilon$ , for any  $\varepsilon > 0$ . Moreover, due to linearity, for any  $a \geq 0$ , the unique solution of the system  $\bar{F}\bar{r} = a \varepsilon \bar{1}$  is  $a \bar{r}_\varepsilon$ . Therefore, for an appropriately small  $\varepsilon > 0$ , the linear system  $\mathcal{Q}_\varepsilon = \{\bar{F}\bar{r} = \varepsilon \bar{1}, f_p - r_p \geq 0 \ \forall p \in \mathcal{P}, f_{kl} + \sum_p r_p \geq 0, d_{p_{kl}}(f') \leq L + b_{kl} - \varepsilon\}$  admits a unique solution  $\bar{r}$ . We keep increasing  $\varepsilon$  until one of the inequalities of  $\mathcal{Q}_\varepsilon$  becomes tight. If it first becomes  $r_p = f_p$  for some path  $p = (s, u_i, v_j, t) \in \mathcal{P}$ , we remove the edge  $\{u_i, v_j\}$  from  $H_1$  and adjust the constant latency of  $e_{kl}$  so that  $d_{p_{kl}}(f') = L - \varepsilon$ . Then, the flow  $f'$



is an equilibrium flow of cost  $L - \varepsilon$  for the resulting network, which has one edge less than the original network  $H_1$ . If  $\sum_p r_p < 0$  and it first becomes  $\sum_p r_p = -f_{kl}$ , we remove the edge  $e_{kl}$  from  $H_1$ . Then,  $f'$  is an equilibrium flow of cost  $L - \varepsilon$  for the resulting network, which again has one edge less than  $H_1$ . If  $\sum_p r_p > 0$  and it first becomes  $d_{p_{kl}}(f') = L + b_{kl} - \varepsilon$ , we set the constant latency of the edge  $e_{kl}$  to  $b'_{kl} = 0$ . In this case,  $f'$  is an equilibrium flow of cost  $L - \varepsilon$  for the resulting network that has one edge of 0 latency more than the initial network  $H_1$ .

If  $\bar{F}$  is singular, proceeding similarly, we compute  $r_p$ 's so that  $f'$  is an equilibrium flow of cost  $L$  in a modified network that includes one edge less than the original network  $H_1$ . When  $\bar{F}$  is singular, the homogeneous linear system  $\bar{F}\bar{r} = \bar{0}$  admits a nontrivial solution  $\bar{r} \neq \bar{0}$ . Moreover, due to linearity, for any  $a \in \mathbb{R}$ ,  $a\bar{r}$  is also a solution to  $\bar{F}\bar{r} = \bar{0}$ . Therefore, the linear system  $\mathcal{Q}_0 = \{\bar{F}\bar{r} = \bar{0}, f_p - r_p \geq 0 \ \forall p \in \mathcal{P}, f_{kl} + \sum_p r_p \geq 0\}$  admits a solution  $\bar{r} \neq \bar{0}$  that makes at least one of the inequalities tight. We recall that the  $p$ -th component of  $\bar{F}\bar{r}$  is equal to  $d_p(f) - d_p(f')$ . Therefore, for the flow  $f'$  obtained from the particular solution  $\bar{r}$  of  $\mathcal{Q}_0$ , the latency of any path  $p \in \mathcal{P}$  is equal to  $L$ . If  $\bar{r}$  is such that  $r_p = f_p$  for some path  $p = (s, u_i, v_j, t) \in \mathcal{P}$ , we remove the edge  $\{u_i, v_j\}$  from  $H_1$  and adjust the constant latency of  $e_{kl}$  so that  $d_{p_{kl}}(f') = L$ . Then, the flow  $f'$  is an equilibrium flow of cost  $L$  for the resulting network, which has one edge less than the original network  $H_1$ . If  $\bar{r}$  is such that  $\sum_p r_p = -f_{kl}$ , we remove the edge  $e_{kl}$  from  $H_1$ . Then,  $f'$  is an equilibrium flow of cost  $L$  for the resulting network, which again has one edge less than  $H_1$ .

Each time we apply the procedure above either we decrease the number of edges of the intermediate network by one or we increase the number of 0-latency edges of the intermediate network by one, without increasing the latency of the equilibrium flow. Moreover, if  $p_{kl}$  is disjoint to the paths  $p \in \mathcal{P}$ ,  $\bar{F}$  is non-singular (next paragraph) and the procedure above leads to a decrease in the equilibrium latency, and eventually to setting  $b'_{kl} = 0$ . So by repeatedly applying these steps, we end up with a subnetwork  $H'$  of the 0-latency simplification of  $H$  with  $L(H', r) \leq L(H, r)$ .

To show that if  $p_{kl}$  is disjoint to the paths  $p \in \mathcal{P}$ ,  $\bar{F}$  is non-singular we show that the matrix  $\bar{F}$  is positive definite (which implies that  $\bar{F}$  is non-singular). We first note that if  $p_{kl}$  is disjoint to all  $p \in \mathcal{P}$ , then for all  $p_1, p_2 \in \mathcal{P}$ ,  $\bar{F}[p_1, p_2] = \sum_{e \in p_1 \cap p_2} a_e$ . Hence, for all  $\bar{x} \in \mathbb{R}^{|\mathcal{P}|}$ ,  $\bar{x}^T \bar{F} \bar{x} = \sum_{e \in E(\mathcal{P})} a_e x_e^2 \geq 0$ , where  $E(\mathcal{P})$  denotes the set of edges included in the paths of  $\mathcal{P}$  and  $x_e = \sum_{p: e \in p} x_p$ . Since the intermediate network of  $H_1$  is acyclic and any flow in  $H_1$  has a unique path decomposition, if  $\bar{x}$  has one or more non-zero components, there is at least one edge  $e$  adjacent to either  $s$  or  $t$  such that  $x_e > 0$ , and thus  $\bar{x}^T \bar{F} \bar{x} > 0$ . Otherwise, the difference of the flow

defined by  $\bar{x}$  with the trivial flow defined by  $\bar{0}$  would indicate the existence of a cycle in the intermediate subnetwork of  $H_1$ . This is a contradiction, since by the first part of the proof, the intermediate part of  $H_1$  is acyclic.  $\square$

## 12.4 Approximating the Best Subnetwork of Simplified Networks

We proceed to show how to approximate the BestSubEL problem in a balanced 0-latency simplified network  $G_0$  with reasonable latencies. We may always regard  $G_0$  as the 0-latency simplification of a good network  $G$ . We first prove two useful lemmas (lemmas 12.3 and 12.4) about the maximum traffic rate  $r$  up to which BestSubEL remains interesting, and about the maximum amount of flow routed on any edge / path in the best subnetwork.

**Lemma 12.3.** Let  $G_0$  be any 0-latency simplified network, let  $r > 0$ , and let  $H_0^*$  be the best subnetwork of  $(G_0, r)$ . For any  $\varepsilon > 0$ , if  $r > \frac{B_{\max} n_+}{A_{\min} \varepsilon}$ , then  $L(G_0, r) \leq (1 + \varepsilon)L(H_0^*, r)$ .

*Proof.* We first show that for 0-latency simplified instances  $(G_0, r)$ , we can assume, essentially wlog., that the traffic rate  $r = O(n_+/\varepsilon)$ . Otherwise, a Nash flow  $f$  of  $(G_0, r)$  is an  $(1 + \varepsilon)$ -approximation of the BestSubEL problem in  $(G_0, r)$ .

To go on with the proof, we assume that  $r > \frac{B_{\max} n_+}{A_{\min} \varepsilon}$ , let  $f$  be a Nash flow of  $(G_0, r)$ , and consider how  $f$  allocates  $r$  units of flow to the edges of  $E_s \equiv E_s(G_0)$  and to the edges  $E_t \equiv E_t(G_0)$ . For simplicity, we let  $L \equiv L(G_0, r)$  denote the equilibrium latency of  $G_0$ , and let  $A_s = \sum_{e \in E_s} 1/a_e$  and  $A_t = \sum_{e \in E_t} 1/a_e$ .

Since  $G_0$  is a 0-latency simplified network and  $f$  is a Nash flow of  $(G_0, r)$ , there are  $L_1, L_2 > 0$ , with  $L_1 + L_2 = L$ , such that all used edges incident to  $s$  (resp. to  $t$ ) have latency  $L_1$  (resp.  $L_2$ ) in the Nash flow  $f$ . Since  $r > \frac{B_{\max} n_+}{A_{\min}}$ ,  $L_1, L_2 > B_{\max}$  and all edges in  $E_s \cup E_t$  are used by  $f$ . Moreover, by an averaging argument, we have that there is an edge  $e \in E_s$  with  $a_e f_e \leq r/A_s$ , and that there is an edge  $e \in E_t$  with  $a_e f_e \leq r/A_t$ . Therefore,  $L_1 \leq (r/A_s) + B_{\max}$  and  $L_2 \leq (r/A_t) + B_{\max}$ , and thus,  $L \leq \frac{r}{A_s} + \frac{r}{A_t} + 2B_{\max}$ .

On the other hand, if we ignore the additive terms  $b_e$  of the latency functions, the optimal average latency of the players is  $r/A_s + r/A_t$ , which implies that  $L(H_0^*, r) \geq r/A_s + r/A_t$ . Therefore,  $L \leq L(H_0^*, r) + 2B_{\max}$ . More-

over, since  $r > \frac{B_{\max} n_+}{A_{\min} \varepsilon}$ ,  $A_s \leq n_s / A_{\min}$ , and  $A_t \leq n_t / A_{\min}$ , we have that:

$$\begin{aligned} L(H_0^*, r) &\geq \frac{r}{A_s} + \frac{r}{A_t} \\ &\geq \frac{B_{\max} n_s}{A_{\min} \varepsilon} \frac{A_{\min}}{n_s} + \frac{B_{\max} n_t}{A_{\min} \varepsilon} \frac{A_{\min}}{n_t} \\ &\geq 2B_{\max} / \varepsilon \end{aligned}$$

Therefore,  $2B_{\max} \leq \varepsilon L(H_0^*, r)$ , and  $L \leq (1 + \varepsilon)L(H_0^*, r)$ . □

**Lemma 12.4.** Let  $G_0$  be a balanced 0-latency simplified network with reasonable latencies, let  $r > 0$ , and let  $f$  be a Nash flow of the best subnetwork of  $(G_0, r)$ . For any  $\varepsilon > 0$ , if  $\Pr[\mathcal{B} \leq \varepsilon/4] \geq \delta$ , for some constant  $\delta > 0$ , there exists a constant  $\rho = \frac{24A_{\max}B_{\max}}{\delta\varepsilon A_{\min}^2}$  such that with probability at least  $1 - e^{-\delta n_-/8}$ ,  $f_e \leq \rho$ , for all edges  $e$ .

*Proof.* We proceed to show that in a 0-latency simplified instance  $(G_0, r)$ , the best subnetwork Nash flow routes  $O(r/n_+)$  units of flow on any edge and on any  $s-t$  path with high probability (where the probability is with respect to the random choice of the latency function coefficients). Intuitively, we show that in the best subnetwork Nash flow, with high probability, all used edges and all used  $s-t$  paths route a volume of flow not significantly larger than their fair share. We first prove the following technical lemma:

**Lemma 12.5.** Let  $G_0$  be a balanced 0-latency simplified network with reasonable latencies, let  $r > 0$  be any traffic rate, and let  $f$  be any Nash flow of the best subnetwork of  $(G_0, r)$ . For any  $\varepsilon > 0$ , if  $L(G, r) \geq \varepsilon$  and  $\Pr[\mathcal{B} \leq \varepsilon/4] \geq \delta$ , for some constant  $\delta > 0$ , there exists a constant  $\gamma = \frac{24A_{\max}}{\delta A_{\min}}$  such that with probability at least  $1 - e^{-\delta n_-/8}$ , for all edges  $e$ ,  $f_e \leq \gamma r / n_+$ .

*Proof.* We let  $L \equiv L(G_0, r)$  denote the equilibrium latency and  $g$  denote a Nash flow of the original instance  $(G_0, r)$ . Since  $G_0$  is a 0-latency simplified network and  $g$  is a Nash flow of  $(G_0, r)$ , there are  $L_1, L_2 > 0$ , with  $L_1 + L_2 = L$ , such that: (i) for any edge  $e$  incident to  $s$ , if  $b_e < L_1$ ,  $g_e > 0$  and  $a_e g_e + b_e = L_1$ , while  $g_e = 0$ , otherwise, and (ii) for any edge  $e$  incident to  $t$ , if  $b_e < L_2$ ,  $g_e > 0$  and  $a_e g_e + b_e = L_2$ , while  $g_e = 0$ , otherwise. Namely, all used edges incident to  $s$  (resp. to  $t$ ) have latency  $L_1$  (resp.  $L_2$ ) in the Nash flow  $g$ . Wlog., we assume that  $L_1 \geq L_2$ , and thus,  $L_1 \geq L/2 \geq \varepsilon/2$ .

We next show that (i) if  $L \geq \varepsilon$  and  $\Pr[\mathcal{B} \leq \varepsilon/4] \geq \delta$ , then with probability at least  $1 - e^{-\delta n_-/8}$ ,  $L \leq \frac{24A_{\max}r}{\delta n_+}$ , and (ii) that for any  $e$ ,  $f_e \leq L/A_{\min}$ . The lemma follows by combining (i) and (ii).

We start with the proof of (i). Let  $e$  be any edge incident to  $s$  with  $b_e \leq \varepsilon/4$ . By the discussion above, in the Nash flow  $g$  of  $(G_0, r)$ ,  $g_e > 0$  and  $\alpha_e g_e + b_e = L_1$ . Using that  $L_1 \geq L/2 \geq \varepsilon/2$ , we obtain that:

$$L_1 = \alpha_e g_e + b_e \leq \alpha_e g_e + \varepsilon/4 \Rightarrow g_e \geq \frac{L_1 - \varepsilon/4}{\alpha_e} \geq \frac{L_1}{2\alpha_e} \geq \frac{L}{4A_{\max}} \quad (12.1)$$

Moreover, since  $\Pr[\mathcal{B} \leq \varepsilon/4] \geq \delta$ , we use Chernoff bounds (e.g., [48, (7)]), and obtain that:

$$\Pr[\{|e \in E_s(G_0) \text{ with } b_e \leq \varepsilon/4\}| \geq \delta n_s/2] \geq 1 - e^{-\delta n_s/8} \quad (12.2)$$

Combining (12.2) and (12.1), we obtain that if  $L \geq \varepsilon$  and  $\Pr[\mathcal{B} \leq \varepsilon/4] \geq \delta$ , with probability at least  $1 - e^{-\delta n_-/8}$ , the flow rate  $r$  is at least  $\frac{L\delta n_s}{8A_{\max}}$ , or equivalently, that:

$$L \leq \frac{8A_{\max}r}{\delta n_s} \leq \frac{24A_{\max}r}{\delta n_+} \quad (12.3)$$

The last inequality holds because  $G_0$  is balanced, and  $|n_s - n_t| \leq 2n_-$ . This concludes the proof of (i).

To prove (ii), we observe that in the best subnetwork equilibrium flow  $f$ , no used edge  $e$  has latency greater than  $L$ . Therefore, for any used edge  $e$  incident to either  $s$  or  $t$ , we have that:

$$\alpha_e f_e + b_e \leq L \Rightarrow f_e \leq \frac{L}{\alpha_e} \leq \frac{L}{A_{\min}} \quad (12.4)$$

Moreover, any edge  $e$  in the intermediate subnetwork of  $G$  has  $f_e \leq L/A_{\min}$  due to the flow conservation constraints. This concludes the proof of (ii).  $\square$

We recall that we always assume that  $L(G, r) \geq \varepsilon$ , since otherwise the problem of approximating BestSubEL is trivial. Moreover, by the definition of reasonable latency functions, we have that for any constant  $\varepsilon > 0$ , there is a constant  $\delta > 0$ , such that  $\Pr[\mathcal{B} \leq \varepsilon/4] \geq \delta$ . Combining these assumptions with Lemma 12.3 and Lemma 12.5, we obtain Lemma 12.4. So from now on, we can assume, with high probability and wlog., that the Nash flow in the best subnetwork of any simplified instance  $(G_0, r)$  routes  $O(1)$  units of flow on any used edge and on any used path.  $\square$

**Approximating the Best Subnetwork of Simplified Networks.** First we state an approximate version of Caratheodory's theorem, proved in [12], that is needed for proving the correctness and efficiency of our approximation scheme.

**Theorem 12.6** ([12], Theorem 3). Let  $X$  be a set of vectors  $X = \{x_1, \dots, x_n\} \subset \mathbb{R}^d$  and  $\varepsilon > 0$ . For every  $\mu \in \text{conv}(X)$  and  $2 \leq p \leq \infty$  there exist an  $O(\frac{p\gamma^2}{\varepsilon^2})$  uniform vector  $\mu' \in \text{conv}(X)$  such that  $\|\mu - \mu'\|_p \leq \varepsilon$ , where  $\gamma = \max_{x \in X} \|x\|_p$  and a  $k$  uniform vector is a vector that can be written as an average of  $k$  vectors of  $X$  with replacements allowed.

We proceed to derive an approximation scheme for the best subnetwork of any simplified instance  $(G_0, r)$ .

**Theorem 12.7.** Let  $G_0$  be a balanced 0-latency simplified network with reasonable latencies, let  $r > 0$ , and let  $H_0^*$  be the best subnetwork of  $(G_0, r)$ . Then, for any  $\varepsilon > 0$ , we can compute, in time  $n_+^{O(A_{\max}^2 r^2 / \varepsilon^2)}$ , a flow  $f$  and a subnetwork  $H_0$  consisting of the edges used by  $f$ , such that (i)  $f$  is an  $\varepsilon$ -Nash flow of  $(H_0, r)$ , (ii)  $L(f) \leq L(H_0^*, r) + \varepsilon/2$ , and (iii) there exists a constant  $\rho > 0$ , such that  $f_e \leq \rho + \varepsilon$ , for all  $e$ .

*Proof.* We will use theorem 12.6 to prove the existence of a flow with the properties (i), (ii) and (iii). Then by exhaustive search we will find one such.

For every path  $p_{ij} = (s, u_i, v_j, t)$  let  $x_{p_{ij}}$  be a vector indexed by the edges of  $E(G_0)$ , i.e.  $x_{p_{ij}} \in \mathbb{R}^{|E(G_0)|}$ , that contains everywhere 0, except from the slots that correspond to edges  $(s, u_i)$ ,  $(u_i, v_j)$  and  $(v_j, t)$  where it contains number  $r$ . Clearly, every feasible flow of  $G_0$  can be written as a convex combination of  $x_{p_{ij}}$ . Let  $k = n_+ \cdot n_-$  be the number of different paths in  $G_0$  and for ease of notation let  $X = \{x_1, \dots, x_k\}$  denote the set containing all  $x_{p_{ij}}$ 's, according to an arbitrary ordering.

Let  $\mu$  be the Nash flow of the best subnetwork  $H_0^*$ . Using theorem 12.6 with set  $X$  as defined above, the Nash flow  $\mu \in \text{conv}(X)$ , the  $\|\cdot\|_2$  norm, i.e.  $p=2$ , and with  $\gamma$  being  $\gamma = r\sqrt{3}$  we get that there is an  $O(\frac{A_{\max}^2 r^2}{\varepsilon^2})$  uniform vector  $f$  such that  $\|\mu - f\|_2 \leq \frac{\varepsilon}{4A_{\max}}$ , which directly implies  $|\mu_e - f_e| \leq \frac{\varepsilon}{4A_{\max}}$  and implies property (iii) for  $f$ , due to Lemma 12.4.

The cost of a path  $p_{ij} = (s, u_i, v_j, t)$  in  $H_0^*$  under  $f$  is  $d_{p_{ij}}(f) = a_i f_{(s,u_i)} + b_i + a_j f_{(v_j,t)} + b_j$ . Because of  $|\mu_e - f_e| \leq \frac{\varepsilon}{4A_{\max}}$  we have

$$a_i \mu_{(s,u_i)} + b_i - \frac{\varepsilon}{4} + a_j \mu_{(v_j,t)} + b_j - \frac{\varepsilon}{4} \leq d_{p_{ij}}(f) \leq a_i \mu_{(s,u_i)} + b_i + \frac{\varepsilon}{4} + a_j \mu_{(v_j,t)} + b_j + \frac{\varepsilon}{4},$$

which gives  $d_{p_{ij}}(\mu) - \frac{\varepsilon}{2} \leq d_{p_{ij}}(f) \leq d_{p_{ij}}(\mu) + \frac{\varepsilon}{2}$ . As  $\mu$  is the Nash flow of the best subnetwork  $H_0^*$  we get

$$L(H_0^*, r) - \frac{\varepsilon}{2} \leq d_p(f) \leq L(H_0^*, r) + \frac{\varepsilon}{2}, \quad (12.5)$$

for any path  $p$  in  $H_0^*$ .

Let  $H_0$  be the subnetwork induced by the paths used by  $f$ . By 12.5,  $f$  in  $H_0$  satisfies (i) and (ii) of the theorem.

One can find such an  $f$  in time  $k^{O(\frac{A_{\max}^2 r^2}{\varepsilon^2})}$  by exhaustively searching for this  $f$  in all possible  $O(\frac{A_{\max}^2 r^2}{\varepsilon^2})$  combinations of the  $k = n_+ \cdot n_-$  paths of  $G_0$ . By checking all possible  $O(\frac{A_{\max}^2 r^2}{\varepsilon^2})$  uniform vectors for each of these combinations and keeping, among all acceptable flows that satisfy (i) and (ii), the acceptable flow  $f$  that minimizes the maximum amount flow routed on any edge, we get  $f_e \leq \rho + \varepsilon$ , for all edges  $e$ , i.e. we get property (iii). The latter is because we know that any Nash flow  $g$  of  $(H_0^*, r)$  routes  $g_e \leq \rho$  units of flow on any edge  $e$  (Lemma 12.4), and that in the exhaustive search step, one of the acceptable flows  $f$  has  $|g_e - f_e| \leq \varepsilon$ , for all edges  $e$  which implies that there is an acceptable flow  $f$  with  $f_e \leq \rho + \varepsilon$ , for all edges  $e$ .  $\square$

## 12.5 Extending the Solution to the Good Network

Given a good instance  $(G, r)$ , we create the 0-latency simplification  $G_0$  of  $G$ , and using Theorem 12.7, we compute a subnetwork  $H_0$  and an  $\varepsilon/6$ -Nash flow  $f$  that comprise an approximate solution to BestSubEL for  $(G_0, r)$ . Next, we show how to extend  $f$  to an approximate solution to BestSubEL for the original instance  $(G, r)$ . The intuition is that the 0-latency edges of  $H_0$  used by  $f$  to route flow from  $V_s$  to  $V_t$  can be “simulated” by low-latency paths of  $G_m$ . We first formalize this intuition for the subnetwork of  $G$  induced by the neighbors of  $s$  with (almost) the same latency  $B_s$  and the neighbors of  $t$  with (almost) the same latency  $B_t$ , for some  $B_s, B_t$  with  $B_s + B_t \approx L(f)$ . We may think of the networks  $G$  and  $H_0$  in the lemma below as some small parts of the original network  $G$  and of the actual subnetwork  $H_0$  of  $G_0$ . Thus, we obtain the following lemma, which serves as a building block in the proof of Lemma 12.9.

**Lemma 12.8.** We assume that  $G(V, E)$  is a  $(n, p, 1)$ -good network, with a possible violation of the maximum degree bound by  $s$  and  $t$ , but with  $|V_s|, |V_t| \leq 3knp/2$ , for some constant  $k > 0$ . Also the latencies of the edges in  $E_s \cup E_t$  are not random, but there exist constants  $B_s, B_t \geq 0$ , such that for all  $e \in E_s$ ,  $d_e(x) = B_s$ , and for all  $e \in E_t$ ,  $d_e(x) = B_t$ . We let  $r > 0$  be any traffic rate, let  $H_0$  be any subnetwork of the 0-latency simplification  $G_0$  of  $G$ , and let  $f$  be any flow of  $(H_0, r)$ . We assume that there exists a constant  $\rho' > 0$ , such that for all  $e \in E(H_0)$ ,  $0 < f_e \leq \rho'$ . Then, for any  $\varepsilon_1 > 0$ , with high probability, wrt. the random choice of the latency functions of  $G$ , we can compute in  $\text{poly}(|V|)$  time a subnetwork  $G'$  of  $G$ , with  $E_s(G') = E_s(H_0)$  and  $E_t(G') = E_t(H_0)$ , and a flow  $g$  of  $(G', r)$  such that

- (i)  $g_e = f_e$  for all  $e \in E_s(G') \cup E_t(G')$ , (ii)  $g$  is a  $7\epsilon_1$ -Nash flow in  $G'$ , and (iii)  $L_{G'}(g) \leq B_s + B_t + 7\epsilon_1$ .

*Proof.* For convenience and wlog., we assume that  $E_s(G) = E_s(H_0)$  and that  $E_t(G) = E_t(H_0)$ , so that we simply write  $V_s$ ,  $V_t$ ,  $E_s$ , and  $E_t$  from now on. For each  $e \in E_s \cup E_t$ , we let  $g_e = f_e$ . So, the flow  $g$  satisfies (i), by construction.

We compute the extension of  $g$  through  $G_m$  as an “almost” Nash flow in a modified version of  $G$ , where each edge  $e \in E_s \cup E_t$  has a capacity  $g_e = f_e$  and a constant latency  $d_e(x) = B_s$ , if  $e \in E_s$ , and  $d_e(x) = B_t$ , if  $e \in E_t$ . All other edges  $e$  of  $G$  have an infinite capacity and a (randomly chosen) reasonable latency function  $d_e(x)$ .

We let  $g$  be the flow of rate  $r$  that respects the capacities of the edges in  $E_s \cup E_t$ , and minimizes  $\text{Pot}(g) = \sum_{e \in E} \int_0^{g_e} d_e(x) dx$ . Such a flow  $g$  can be computed in strongly polynomial time (see e.g., [85]). The subnetwork  $G'$  of  $G$  is simply  $G_g$ , namely, the subnetwork that includes only the edges used by  $g$ . It could have been that  $g$  is not a Nash flow of  $(G, r)$ , due to the capacity constraints on the edges of  $E_s \cup E_t$ . However, since  $g$  is a minimizer  $\text{Pot}(g)$ , for any  $u \in V_s$  and  $v \in V_t$ , and any pair of  $s-t$  paths  $p, p'$  going through  $u$  and  $v$ , if  $g_p > 0$ , then  $d_p(g) \leq d_{p'}(g)$ .

We next adjust the proof of [24, Lemma 5], and show that for any  $s-t$  path  $p$  used by  $g$ ,  $d_p(g) \leq B_s + B_t + 7\epsilon_1$ . To prove this, we let  $p = (s, u, \dots, v, t)$  be the  $s-t$  path used by  $g$  that maximizes  $d_p(g)$ . We show the existence of a path  $p' = (s, u, \dots, v, t)$  in  $G$  of latency  $d_{p'}(g) \leq B_s + B_t + 7\epsilon_1$ . Therefore, since  $g$  is a minimizer of  $\text{Pot}(g)$ , the latency of the maximum latency  $g$ -used path  $p$ , and thus the latency of any other  $g$ -used  $s-t$  path, is at most  $B_s + B_t + 7\epsilon_1$ , i.e.,  $g$  satisfies (iii). Moreover, since for any  $s-t$  path  $p$ ,  $d_p(g) \geq B_s + B_t$ ,  $g$  is an  $7\epsilon_1$ -Nash flow in  $G'$ .

Let  $p = (s, u, \dots, v, t)$  be the  $s-t$  path used by  $g$  that maximizes  $d_p(g)$ . To show the existence of a path  $p' = (s, u, \dots, v, t)$  in  $G$  of latency  $d_{p'}(g) \leq B_s + B_t + 7\epsilon_1$ , we start from  $S_0 = \{u\}$  and grow a sequence of vertex sets  $S_0 \subseteq S_1 \subseteq \dots \subseteq S_{i^*}$ , stopping when  $|\Gamma(S_{i^*})| \geq 3n/5$  for the first time. We use the expansion properties of  $G$ , and condition (3), on the distribution of  $\mathcal{B}$ , in the definition of good networks, and show that these sets grow exponentially fast, and thus,  $i^* \leq \ln n$ , with high probability. Moreover, we show<sup>1</sup> that there are edges of latency  $\epsilon_1 + o(1)$  from  $S_0 = \{u\}$  to each vertex of  $S_1$ , and edges of latency  $\epsilon_1 / \ln n + o(1/\ln n)$  from  $S_i$  to each vertex of  $S_{i+1}$ , for all  $i = 1, \dots, i^* - 1$ . Thus, there is a path of latency at most  $2\epsilon_1 + o(1)$  from  $u$  to each vertex of  $S_{i^*}$ . Similarly, we start from  $T_0 = \{v\}$  and grow a

<sup>1</sup>The intuition is that if among the edges  $e$  incident to  $V_s \cup V_t$ , we keep only those with  $b_e \leq \epsilon_1$ , and among all the remaining edges  $e$ , we keep only those with  $b_e \leq \epsilon_1 / \ln n$ , then due to condition (3) on the distribution of  $\mathcal{B}$ , a good network  $G$  remains an expander.

sequence of vertex sets  $T_0 \subseteq T_1 \subseteq \dots \subseteq T_{j^*}$ , stopping when  $|\Gamma(T_{j^*})| \geq 3n/5$  for the first time. By exactly the same reasoning, we establish the existence of a path of latency at most  $2\epsilon_1 + o(1)$  from each vertex of  $T_{j^*}$  to  $v$ . Finally, since  $|\Gamma(S_{i^*})| \geq 3n/5$  and  $|\Gamma(T_{j^*})| \geq 3n/5$ , the neighborhoods of  $S_{i^*}$  and  $T_{j^*}$  contain at least  $n/10$  vertices in common. With high probability, most of these vertices can be reached from  $S_{i^*}$  and from  $T_{j^*}$  using edges of latency  $\epsilon_1 + o(1)$ . Putting everything together, we find a  $u - v$  path (in fact, many of them) of length  $O(\ln n)$  and latency at most  $6\epsilon_1 + o(1) \leq 7\epsilon_1$ .

For completeness, we next give a detailed proof, by adjusting the arguments in the proof of [24, Lemma 5]. For convenience, for each vertex  $x$ , we let  $d_s(x)$  (resp.  $d_t(x)$ ) be the latency wrt  $g$  of the shortest latency path from  $s$  to  $x$  (resp. from  $x$  to  $t$ ). Also, for any  $\delta > 0$ , we let  $P_b(\delta) \equiv \Pr[\mathcal{B} \leq \delta]$  denote the probability that the additive term of a reasonable latency is at most  $\delta$ . Recall also that by hypothesis, there exists a constant  $\rho' > 0$ , such that for all  $e \in E(H_0)$ ,  $f_e \leq \rho'$ . Hence, the total flow through  $G$  (and through  $H_0$ ) is  $r \leq \rho' n_+$ .

At the conceptual level, the proof proceeds as explained above. We start with  $S_0 = \{u\}$ . By hypothesis, the flow entering  $u$  is at most  $\rho'$ . By the expansion property of good networks and by Chernoff bounds<sup>2</sup>, with high probability, there are at least  $P_b(\epsilon_1)np/4$  edges  $e$  adjacent to  $u$  with  $b_e \leq \epsilon_1$ . At most half of these edges have flow greater than  $\frac{8\rho'}{P_b(\epsilon_1)np}$ , thus there are at least  $P_b(\epsilon_1)np/8$  edges adjacent to  $u$  with latency, wrt  $g$ , less than  $\frac{8A_{\max}\rho'}{P_b(\epsilon_1)np} + \epsilon_1$ . We now let  $d_1 = B_s + \frac{8A_{\max}\rho'}{P_b(\epsilon_1)np} + \epsilon_1$  and  $S_1 = \{x \in V : d_s(x) \leq d_1\}$ . By the discussion above,  $|S_1| \geq P_b(\epsilon_1)np/8$ .

We now inductively define a sequence of vertex sets  $S_i$  and upper bounds  $d_i$  on the latency of the vertices in  $S_i$  from  $s$ , such that  $S_i \subseteq S_{i+1}$  and  $d_i < d_{i+1}$ . This sequence stops the first time that  $|\Gamma(S_i)| \geq 3n/5$ . We inductively assume that the vertex set  $S_i$  and the upper bound  $d_i$  on the latency of the vertices in  $S_i$  are defined, and that  $|\Gamma(S_i)| < 3n/5$ . By the expansion property of good networks  $|\Gamma(S_i) \setminus S_i| \geq np|S_i|/3$ , for sufficiently large  $n$ . Thus, with probability at least  $1 - e^{-P_b(\epsilon_1/\ln n)np|S_i|/24}$ , there are at least  $P_b(\frac{\epsilon_1}{\ln n})np|S_i|/6$  vertices outside  $S_i$  that are connected to a vertex in  $S_i$  by an edge  $e$  with  $b_e \leq \epsilon_1/\ln n$ . Let  $S'_i$  be the set of such vertices, and let  $E_i$  be the set of edges that for each vertex  $v \in S'_i$ , includes a unique edge  $e \in E_i$  with  $b_e \leq \epsilon_1/\ln n$  connecting  $v$  to a vertex in  $S_i$ . Since the flow  $g$  may be assumed to be acyclic, a volume  $r \leq \rho' n_+$  of flow is routed through the cut  $(S_i, V \setminus S_i)$ . Then, at most half of the edges in  $E_i$  have flow greater than

<sup>2</sup>We repeatedly use the following form of the Chernoff bound (see e.g., [48]): Let  $X_1, \dots, X_k$  be random variables independently distributed in  $\{0, 1\}$ , and let  $X = \sum_{i=1}^k X_i$ . Then, for all  $\epsilon \in (0, 1)$ ,  $\Pr[X < (1 - \epsilon)\mathbf{E}[X]] \leq e^{-\epsilon^2 \mathbf{E}[X]/2}$ , where  $e$  is the basis of natural logarithms.



$2\rho'n_+/|S'_i|$ . Consequently, at least half of the vertices  $v \in S'_i$  have latency from  $s$ :

$$\begin{aligned} d_s(x) &\leq d_i + \frac{\epsilon_1}{\ln n} + A_{\max} \frac{2\rho'n_+}{|S'_i|} \\ &\leq d_i + \frac{\epsilon_1}{\ln n} + \frac{12A_{\max}\rho'n_+}{P_b(\frac{\epsilon_1}{\ln n})np|S_i|} \end{aligned}$$

Thus, we define the next latency upper bound  $d_{i+1}$  in the sequence as:

$$d_{i+1} = d_i + \frac{\epsilon_1}{\ln n} + \frac{12A_{\max}\rho'n_+}{P_b(\frac{\epsilon_1}{\ln n})np|S_i|},$$

and we let  $S_{i+1} = \{x \in V(G) | d_s(x) \leq d_{i+1}\}$ . By the discussion above, and using the inductive definition of  $S_i$ 's, we obtain that:

$$\begin{aligned} |S_{i+1}| &\geq \left(\frac{1}{12}P_b(\epsilon_1/\ln n)np + 1\right)|S_i| \\ &\geq \left(\frac{1}{12}P_b(\epsilon_1/\ln n)np + 1\right)^i |S_1| \end{aligned}$$

We recall that  $i^*$  is the first index  $i$  such that  $|\Gamma(S_i)| \geq 3n/5$ . Then, the inequality above implies that:

$$i^* \leq \frac{\ln(3n/(5|S_1|))}{\ln\left(\frac{1}{12}P_b(\epsilon_1/\ln n)np + 1\right)} \leq \frac{\ln(24n/(5P_b(\epsilon_1)np))}{\ln\left(\frac{1}{12}P_b(\epsilon_1/\ln n)np + 1\right)}$$

Using that  $pn \geq \ln n$  and that  $P_b(\epsilon_1/\ln n)np = \omega(1)$ , the inequality above implies that  $i^* \leq \ln n$ , for sufficiently large  $n$ .

Therefore, we obtain an upper bound on the latency from  $s$  of any vertex in  $S_{i^*}$ :

$$\begin{aligned} d_{i^*} &\leq d_0 + i^* \frac{\epsilon_1}{\ln n} + \sum_{i=1}^{i^*} \frac{12A_{\max}\rho'n_+}{P_b(\frac{\epsilon_1}{\ln n})np|S_i|} \\ &\leq d_1 + \frac{\epsilon_1}{\ln n} \ln n + \sum_{i=1}^{\ln n} \frac{12A_{\max}\rho'n_+}{P_b(\frac{\epsilon_1}{\ln n})np \left(\frac{1}{12}P_b(\frac{\epsilon_1}{\ln n})np + 1\right)^i |S_1|} \\ &= d_1 + \epsilon_1 + \frac{12A_{\max}\rho'n_+}{P_b(\frac{\epsilon_1}{\ln n})np|S_1|} \sum_{i=1}^{\ln n} \left(\frac{1}{12}P_b(\frac{\epsilon_1}{\ln n})np + 1\right)^{-i} \\ &\leq \left(B_s + \frac{8A_{\max}\rho'}{P_b(\epsilon_1)np} + \epsilon_1\right) + \epsilon_1 + \frac{96A_{\max}\rho'n_+}{P_b(\frac{\epsilon_1}{\ln n})P_b(\epsilon_1)(np)^2} \sum_{i=1}^{\infty} 2^{-i} \\ &\leq B_s + 2\epsilon_1 + \frac{8A_{\max}\rho'}{P_b(\epsilon_1)np} + \frac{144A_{\max}\rho'k}{P_b(\frac{\epsilon_1}{\ln n})P_b(\epsilon_1)np} \end{aligned}$$

For the penultimate inequality, we use that  $P_b(\epsilon_1/\ln n)np = \omega(1)$ , which implies that  $1 + P_b(\epsilon_1/\ln n)np/12 \geq 2$ , for  $n$  sufficiently large. For the last inequality, we use that  $n_+ \leq 3knp/2$ , for some constant  $k > 0$ , by hypothesis.

Moreover, we observe that probability that the above construction fails is at most:

$$\begin{aligned} \sum_{i=1}^{i^*} e^{-P_b(\epsilon_1/\ln n)np|S_i|/24} &\leq \sum_{i=1}^{i^*} e^{-\left(\frac{1}{12}P_b(\epsilon_1/\ln n)np+1\right)^i|S_i|/24} \\ &\leq \ln n e^{-\left(\frac{1}{12}P_b(\epsilon_1/\ln n)np+1\right)P_b(\epsilon_1)np/192} \end{aligned}$$

Therefore, the construction above succeeds with high probability.

Similarly, we start from  $T_0 = \{v\}$ , and inductively define a sequence of vertex sets  $T_0 \subseteq T_1 \subseteq \dots \subseteq T_{j^*}$ , and a sequence of upper bounds  $d'_0 < d'_1 < \dots < d'_{j^*}$  on the latency from  $t$  of the vertices in each  $T_j$ . We let  $T_j = \{x \in V(G) | d_t(x) \leq d'_j\}$ . The sequence stops as soon as  $|\Gamma(T_j)| \geq 3n/5$  for the first time. Namely,  $j^*$  is the first index with  $|\Gamma(T_{j^*})| \geq 3n/5$ . Using exactly the same arguments, we can show that with high probability, we have that  $j^* \leq \ln n$ , and that:

$$d'_{j^*} \leq B_t + 2\epsilon_1 + \frac{8A_{\max}\rho'}{P_b(\epsilon_1)np} + \frac{144A_{\max}\rho'k}{P_b(\frac{\epsilon_1}{\ln n})P_b(\epsilon_1)np}$$

Wlog., we assume that  $S_{i^*} \cap T_{j^*} = \emptyset$ . Since  $|\Gamma(S_{i^*})| + |\Gamma(T_{j^*})| \geq 6n/5$ , there are at least  $n/10$  edge disjoint paths of length at most 2 between  $S_{i^*}$  and  $T_{j^*}$ . Furthermore, by Chernoff bounds, with high probability, there are at least  $P_b(\epsilon_1)^2 n/12$  such paths with both edges  $e$  on the path having  $b_e \leq \epsilon_1$ . At most half of these paths have flow more than  $2\frac{12\rho'n_+}{P_b(\epsilon_1)^2 n}$  and thus there is a path from a vertex of  $S_{i^*}$  to a vertex of  $T_{j^*}$  that costs at most  $2\epsilon_1 + 2A_{\max}\frac{24\rho'n_+}{P_b(\epsilon_1)^2 n}$ .

Putting everything together, we have that there is a path  $p'$  that starts from  $s$ , moves to  $u$ , goes through vertices of the sequence  $S_1, \dots, S_{i^*}$ , proceeds to a vertex of  $\Gamma(S_{i^*}) \cap \Gamma(T_{j^*})$ , and from there, continues through vertices of the sequence  $T_{j^*}, \dots, T_1$ , until finally reaches  $v$ , and then  $t$ . The latency of this path is:

$$d_{p'}(g) \leq B_s + B_t + 6\epsilon_1 + 2\left(\frac{8A_{\max}\rho'}{P_b(\epsilon_1)np} + \frac{48A_{\max}\rho'k}{P_b(\frac{\epsilon_1}{\ln n})P_b(\epsilon_1)np}\right) + \frac{48A_{\max}\rho'n_+}{P_b(\epsilon_1)^2 n}$$

We recall that since the flow  $g$  is a the minimizer of  $\text{Pot}(g)$ , for any  $g$ -used path  $p = (s, u, \dots, v, t)$ ,  $d_p(g) \leq d_{p'}(g)$ . Thus we obtain that any

$g$ -used path  $p = (s, u, \dots, v, t)$  has latency

$$d_p(g) \leq B_s + B_t + 6\epsilon_1 + 2\left(\frac{8A_{\max}\rho'}{P_b(\epsilon_1)np} + \frac{48A_{\max}\rho'k}{P_b(\frac{\epsilon_1}{\ln n})P_b(\epsilon_1)np}\right) + \frac{48A_{\max}\rho'n_+}{P_b(\epsilon_1)^2n}$$

Using the hypothesis that  $n_+ \leq 3knp/2$ , for constant  $k > 0$ , and that  $P_b(\epsilon_1/\ln n)np = \omega(1)$ , which is condition (3), in the definition of good networks, we obtain that for any constant  $\epsilon_1 > 0$ ,  $d_p(g) \leq B_s + B_t + 7\epsilon_1$ , for sufficiently large  $n$ .  $\square$

**Grouping the Neighbors of  $s$  and  $t$ .** Let us now consider the entire network  $G$  and the entire subnetwork  $H_0$  of  $G_0$ . Lemma 12.8 can be applied only to subsets of edges in  $E_s(H_0)$  and in  $E_t(H_0)$  that have (almost) the same latency under  $f$ . Hence, we partition the neighbors of  $s$  and the neighbors of  $t$  into classes  $V_s^i$  and  $V_t^j$  according to their latency. For convenience, we let  $\epsilon_2 = \epsilon/6$ , i.e.,  $f$  is an  $\epsilon_2$ -Nash flow, and  $L \equiv L_{H_0}(f)$ . By Theorem 12.7, applied with error  $\epsilon_2 = \epsilon/6$ , there exists a  $\rho$  such that for all  $e \in E(H_0)$ ,  $0 < f_e \leq \rho + \epsilon_2$ . Hence,  $L \leq 2A_{\max}(\rho + \epsilon_2) + 2B_{\max}$  is bounded by a constant.

We partition the interval  $[0, L]$  into  $\kappa = \lceil L/\epsilon_2 \rceil$  subintervals, where the  $i$ -th subinterval is  $I^i = (i\epsilon_2, (i+1)\epsilon_2]$ ,  $i = 0, \dots, \kappa - 1$ . We partition the vertices of  $V_s$  (resp. of  $V_t$ ) that receive positive flow by  $f$  into  $\kappa$  classes  $V_s^i$  (resp.  $V_t^i$ ),  $i = 0, \dots, \kappa - 1$ . Precisely, a vertex  $x \in V_s$  (resp.  $x \in V_t$ ), connected to  $s$  (resp. to  $t$ ) by the edge  $e_x = \{s, x\}$  (resp.  $e_x = \{x, t\}$ ), is in the class  $V_s^i$  (resp. in the class  $V_t^i$ ), if  $d_{e_x}(f_{e_x}) \in I_i$ . If a vertex  $x \in V_s$  (resp.  $x \in V_t$ ) does not receive any flow from  $f$ ,  $x$  is removed from  $G$  and does not belong to any class. Hence, from now on, we assume that all neighbors of  $s$  and  $t$  receive positive flow from  $f$ , and that  $V_s^0, \dots, V_s^{\kappa-1}$  (resp.  $V_t^0, \dots, V_t^{\kappa-1}$ ) is a partitioning of  $V_s$  (resp.  $V_t$ ). In exactly the same way, we partition the edges of  $E_s$  (resp. of  $E_t$ ) used by  $f$  into  $\kappa$  classes  $E_s^i$  (resp.  $E_t^i$ ),  $i = 0, \dots, \kappa - 1$ .

To find out which parts of the subnetwork  $H_0$  will be connected through the intermediate subnetwork of  $G$ , using the construction of Lemma 12.8, we further classify the vertices of  $V_s^i$  and  $V_t^j$  based on the neighbors of  $t$  and on the neighbors of  $s$ , respectively, to which they are connected by  $f$ -used edges in the subnetwork  $H_0$ . In particular, a vertex  $u \in V_s^i$  belongs to the classes  $V_s^{(i,j)}$ , for all  $j \in \{0, \dots, \kappa - 1\}$  such that there is a vertex  $v \in V_t^j$  with  $f_{\{u,v\}} > 0$ . Similarly, a vertex  $v \in V_t^j$  belongs to the classes  $V_t^{(i,j)}$ , for all  $i \in \{0, \dots, \kappa - 1\}$  such that there is a vertex  $u \in V_s^i$  with  $f_{\{u,v\}} > 0$ . We note that a vertex  $u \in V_s^i$  (resp.  $v \in V_t^j$ ) may belong to many different classes  $V_s^{(i,j)}$  (resp. to  $V_t^{(i,j)}$ ), and that the class  $V_s^{(i,j)}$  is non-empty iff the class  $V_t^{(i,j)}$  is non-empty, i.e., non-empty classes  $V_s^{(i,j)}$  and  $V_t^{(i,j)}$  appear in pairs. We let  $k \leq \kappa^2$  be the number of pairs  $(i, j)$  for which  $V_s^{(i,j)}$  and  $V_t^{(i,j)}$  are non-empty. We note that  $k$  is a constant, i.e., does not depend on  $|V|$  and  $r$ . We let  $E_s^{(i,j)}$

be the set of edges connecting  $s$  to the vertices in  $V_s^{(i,j)}$  and  $E_t^{(i,j)}$  be the set of edges connecting  $t$  to the vertices in  $V_t^{(i,j)}$ .

**Building the Intermediate Subnetworks of  $G$ .** The last step is to replace the 0-latency simplified parts connecting the vertices of each pair of classes  $V_s^{(i,j)}$  and  $V_t^{(i,j)}$  in  $H_0$  with a subnetwork of  $G_m$ . To this end, we randomly partition the set  $V_m$  of intermediate vertices of  $G$  into  $k$  subsets, each of cardinality (roughly)  $|V_m|/k$ , and associate a different such subset  $V_m^{(i,j)}$  with any pair of non-empty classes  $V_s^{(i,j)}$  and  $V_t^{(i,j)}$ . For each pair  $(i,j)$  for which the classes  $V_s^{(i,j)}$  and  $V_t^{(i,j)}$  are non-empty, we consider the induced subnetwork  $G^{(i,j)} \equiv G[\{s, t\} \cup V_s^{(i,j)} \cup V_m^{(i,j)} \cup V_t^{(i,j)}]$ , which is a  $(n/k, p, 1)$ -good network, by condition (4) in the definition of good networks, and because  $G$  is a  $(n, p, k)$ -good network. Therefore, we can apply Lemma 12.8 to  $G^{(i,j)}$ , with  $H_0^{(i,j)} \equiv H_0[\{s, t\} \cup V_s^{(i,j)} \cup V_t^{(i,j)}]$  in the role of  $H_0$ , the restriction  $f^{(i,j)}$  of  $f$  to  $H_0^{(i,j)}$  in the role of the flow  $f$ , and  $\rho' = \rho + \epsilon_2$ . Moreover, we let  $B_s^{(i,j)} = \max_{e \in E_s^{(i,j)}} d_e(f_e)$  and  $B_t^{(i,j)} = \max_{e \in E_t^{(i,j)}} d_e(f_e)$  correspond to  $B_s$  and  $B_t$ , and introduce constant latencies  $d'_e(x) = B_s^{(i,j)}$  for all  $e \in E_s^{(i,j)}$  and  $d'_e(x) = B_t^{(i,j)}$  for all  $e \in E_t^{(i,j)}$ , as required by Lemma 12.8. Thus, we obtain, with high probability, a subnetwork  $H^{(i,j)}$  of  $G^{(i,j)}$  and a flow  $g^{(i,j)}$  that routes as much flow as  $f^{(i,j)}$  on all edges of  $E_s^{(i,j)} \cup E_t^{(i,j)}$ , and satisfies the conclusion of Lemma 12.8, if we keep in  $H^{(i,j)}$  the constant latencies  $d'_e(x)$  for all  $e \in E_s^{(i,j)} \cup E_t^{(i,j)}$ .

The final outcome is the union of the subnetworks  $H^{(i,j)}$ , denoted  $H$  ( $H$  has the latency functions of the original instance  $G$ ), and the union of the flows  $g^{(i,j)}$ , denoted  $g$ , where the union is taken over all  $k$  pairs  $(i,j)$  for which the classes  $V_s^{(i,j)}$  and  $V_t^{(i,j)}$  are non-empty. By construction, all edges of  $H$  are used by  $g$ . We obtain lemma 12.9 by showing that if  $\epsilon_1 = \epsilon/42$  and  $\epsilon_2 = \epsilon/6$ , the flow  $g$  is an  $\epsilon$ -Nash flow of  $(H, r)$ , and satisfies  $L_H(g) \leq L_{H_0}(f) + \epsilon/2$ .

**Lemma 12.9.** Let any  $\epsilon > 0$ , let  $k = \lceil 12(A_{\max}(\rho + \epsilon) + B_{\max})/\epsilon \rceil^2$ , let  $G(V, E)$  be an  $(n, p, k)$ -good network, let  $r > 0$ , let  $H_0$  be any subnetwork of the 0-latency simplification of  $G$ , and let  $f$  be an  $(\epsilon/6)$ -Nash flow of  $(H_0, r)$  for which there exists a constant  $\rho' > 0$ , such that for all  $e \in E(H_0)$ ,  $0 < f_e \leq \rho'$ . Then, with high probability, wrt. the random choice of the latency functions of  $G$ , we can compute in  $\text{poly}(|V|)$  time a subnetwork  $H$  of  $G$  and an  $\epsilon$ -Nash flow  $g$  of  $(H, r)$  with  $L_H(g) \leq L_{H_0}(f) + \epsilon/2$ .

*Proof.* We consider the subnetwork  $H$  (with the original latency functions of  $G$ ), computed as the union of subnetworks  $H^{(i,j)}$ , and the flow  $g$ , computed as the union of the flows  $g^{(i,j)}$ , where the union is taken over all  $k$  pairs  $(i,j)$  for which the classes  $V_s^{(i,j)}$  and  $V_t^{(i,j)}$  are non-empty. We recall that by

construction, all edges of  $H$  are used by  $g$ . We show that if  $\epsilon_1 = \epsilon/42$  and  $\epsilon_2 = \epsilon/6$ , the flow  $g$  is an  $\epsilon$ -Nash flow of  $(H, r)$ , and satisfies  $L_H(g) \leq L_{H_0}(f) + \epsilon/2$ . We stress that the edge and path latencies here are calculated with respect to the original latency functions of  $G$  and under the edge congestion induced by the flow  $g$  (or the flow  $f$ ).

For convenience, we let  $B^{(i,j)} = B_s^{(i,j)} + B_t^{(i,j)}$  for any pair of non-empty classes  $V_s^{(i,j)}$  and  $V_t^{(i,j)}$ . Since the difference in the latency of any edges in the same group is at most  $\epsilon_2$ , we obtain that for any edge  $e \in E_s^{(i,j)}$ ,  $B_s^{(i,j)} - \epsilon_2 \leq d_e(f_e) \leq B_s^{(i,j)}$ , and similarly, that for any edge  $e \in E_t^{(i,j)}$ ,  $B_t^{(i,j)} - \epsilon_2 \leq d_e(f_e) \leq B_t^{(i,j)}$ . Therefore, since  $H_0$  is a 0-latency simplified network, and since by hypothesis, all the edges of  $H_0$  are used by  $f$ , for any pair of non-empty classes  $V_s^{(i,j)}$  and  $V_t^{(i,j)}$ , and for any  $s-t$  path  $p$  going through a vertex of  $V_s^{(i,j)}$  and a vertex of  $V_t^{(i,j)}$ ,

$$B^{(i,j)} - 2\epsilon_2 \leq d_p(f) \leq B^{(i,j)}$$

Moreover, since  $f$  is an  $\epsilon_2$ -Nash flow of  $(H_0, r)$ , for any  $s-t$  path  $p \in \mathcal{P}_{H_0}$ ,

$$L_{H_0}(f) - \epsilon_2 \leq d_p(f) \leq L_{H_0}(f)$$

Combining the two inequalities above, we obtain that for any pair of non-empty classes  $V_s^{(i,j)}$  and  $V_t^{(i,j)}$ ,

$$B^{(i,j)} - 2\epsilon_2 \leq L_{H_0}(f) \leq B^{(i,j)} + \epsilon_2 \quad (12.6)$$

As for the flow  $g$ , by construction, we have that  $g_e = f_e$  for all edges  $e \in E_s \cup E_t$ . Therefore, for any edge  $e \in E_s^{(i,j)}$ ,  $B_s^{(i,j)} - \epsilon_2 \leq d_e(g_e) \leq B_s^{(i,j)}$ , and similarly, for any edge  $e \in E_t^{(i,j)}$ ,  $B_t^{(i,j)} - \epsilon_2 \leq d_e(g_e) \leq B_t^{(i,j)}$ . Thus, by Lemma 12.8, and since all the edges of any subnetwork  $H^{(i,j)}$  are used by  $g$ , for any  $s-t$  path  $p$  in the subnetwork  $H^{(i,j)}$ ,  $B^{(i,j)} - 2\epsilon_2 \leq d_p(g) \leq B^{(i,j)} + 7\epsilon_1$ . Using that (12.6), we obtain that for any subnetwork  $H^{(i,j)}$  and any  $s-t$  path  $p$  of  $H^{(i,j)}$ ,

$$L_{H_0}(f) - 3\epsilon_2 \leq d_p(g) \leq L_{H_0}(f) + 2\epsilon_2 + 7\epsilon_1 \quad (12.7)$$

Furthermore, we recall that the subnetworks  $H^{(i,j)}$  only have in common the vertices  $s$  and  $t$ , and possibly some vertices of  $V_s \cup V_t$  and some edges of  $E_s \cup E_t$ . They have neither any other vertices in common, nor any edges connecting vertices in the intermediate parts of different subnetworks  $H^{(i,j)}$  and  $H^{(i',j')}$ . Hence, any  $s-t$  path  $p$  of  $H$  passes through a single subnetwork  $H^{(i,j)}$ . Therefore, and since by construction, all the edges and the paths of  $H$  are used by  $g$ , (12.7) holds for any  $s-t$  path  $p$  of  $H$ .

Thus, we have shown that  $g$  is a  $(5\epsilon_2 + 7\epsilon_1)$ -Nash flow of  $(H, r)$ , and that  $L_H(g) \leq L_{H_0}(f) + 2\epsilon_2 + 7\epsilon_1$ . Using  $\epsilon_2 = \epsilon/6$  and  $\epsilon_1 = \epsilon/42$ , we obtain the performance guarantees of  $g$  as stated in Lemma 12.9.  $\square$



## Chapter 13

# Congestion Games with Risk Averse Players

Congestion games ignore the stochastic nature of resource delays and the risk-averse attitude of the players to uncertainty. To take these aspects into account, we introduce two variants of atomic congestion games, one with *stochastic players*, where each player assigns load to her strategy independently with a given probability, and another with *stochastic edges*, where the latency functions are random. In both variants, the players are risk-averse, and their individual cost is a player-specific quantile of their delay distribution. We focus on parallel-link networks and investigate how the main properties of stochastic congestion games depend on the risk attitude and the participation probabilities of the players. In a nutshell, we prove that stochastic congestion games on parallel-links admit an efficiently computable pure Nash equilibrium if the players have either the same risk attitude or the same participation probabilities, and also admit a potential function if the players have the same risk attitude. On the negative side, we present examples of stochastic games with players of different risk attitudes that do not admit a potential function. As for the inefficiency of equilibria, for parallel-link networks with linear delays, we prove that the Price of Anarchy is  $\Theta(n)$ , where  $n$  is the number of stochastic players, and may be unbounded, in case of stochastic edges.

### 13.1 Introducing the Models

In this chapter we generalize atomic congestion games. Recall that a (standard) atomic CG is the tuple  $\mathcal{G}(N, E, (S_i)_{i \in N}, (d_e)_{e \in E})$ . On the corresponding sections we will get more specific on the generalization we do, by explicitly

defining the generalizing models.

In the technical part, we restrict our attention to symmetric congestion games on parallel-link networks, where strategies are singletons and there is a strategy for every resource. Since we mostly consider networks, we use the terms “resource” and “edge” and “strategy” and “path” interchangeably.

## 13.2 Congestion Games with Stochastic Players

### 13.2.1 The Model

In Congestion Games with Stochastic Players, each player  $i$  is described by a tuple  $(p_i, \delta_i)$ , where  $p_i \in [0, 1]$  is the probability that player  $i$  participates in the game, by assigning a unit of load to her strategy, and  $\delta_i \in [\frac{1}{2}, 1]$  is the *confidence level* (or risk-aversion) of player  $i$ . Essentially, each player  $i$  is associated with a Bernoulli random variable  $X_i$  that is 1 with probability  $p_i$ , and 0 with probability  $1 - p_i$ . Then, the load of each edge  $e$  in a configuration  $s$  is the random variable  $N_e(s) = \sum_{i: e \in s_i} X_i$ , and the cost of a strategy  $q$  in  $s$  is the random variable  $D_q(s) = \sum_{e \in q} d_e(N_e(s))$ .

Given that player  $i$  participates in the game, the delay of player  $i$  in  $s$  is given by the random variable:

$$D_i(s) = \sum_{e \in s_i} d_e \left( 1 + \sum_{j \neq i: e \in s_j} X_j \right).$$

Note that when  $X_i = 1$ ,  $D_i(s) = D_{s_i}(s)$ .

The (risk-averse) individual cost  $c_i(s)$  perceived by player  $i$  in  $s$  is the  $\delta_i$ -quantile (or value-at-risk) of  $D_i(s)$ . Formally,  $c_i(s) = \min\{t : \Pr[D_i(s) \leq t] \geq \delta_i\}$ . We note that for parallel-link networks, the (risk-averse) individual cost of the players can be computed efficiently. PNE are defined as before, but with respect to the risk-averse individual cost of the players.

Depending on whether players have the same participation probabilities  $p_i$  and/or the same confidence levels  $\delta_i$ , we distinguish between four classes of congestion games with stochastic players:

- *homogeneous*, where all players have the same participation probability  $p$  and confidence level  $\delta$ .
- *p-homogeneous*, where all players have the same participation probability  $p$ , but may have different confidence levels.



- $\delta$ -homogeneous, where all players have the same confidence level  $\delta$ , but may have different participation probabilities.
- heterogeneous, where both the participation probabilities and the confidence levels may be different.

### 13.2.2 Stochastic Players on Parallel Links: Existence and Computation of PNE

In the following, we restrict ourselves to Congestion Games with Stochastic Players on parallel-link networks, and investigate the existence and the efficient computation of PNE for the four cases considered above.

**Homogeneous Stochastic Players.** If the players are homogeneous, stochastic congestion games on parallel-links are equivalent to standard congestion games on parallel-links (but with possibly different latencies), because the (risk-averse) individual cost of each player in a configuration  $s$  depends only on the link  $e$  and its congestion  $s_e$ .

**Theorem 13.1.** Congestion Games with Homogeneous Stochastic Players on parallel-link networks admit an exact potential function. Moreover, a pure Nash equilibrium can be computed in polynomial time.

*Proof.* The existence of a potential function implies the existence of equilibrium. Rosenthal's potential function ([73]) suits this case as players, under any configuration, perceive exactly the same cost on any edge  $e$ , a cost that depends only on the number of players on  $e$ .

Formally, let  $p$  and  $\delta$  denote the common  $p_i$ 's and  $\delta_i$ 's of the players, and for each edge  $e$ , define a function  $f_e : \mathbb{N} \rightarrow \mathbb{R}$  with

$$f_e(r) = \begin{cases} 0, & \text{if } r = 0 \\ \min \left\{ t : \Pr \left[ d_e (1 + \sum_{i=1}^{r-1} Y_i) \leq t \right] \geq \delta \right\}, & \text{if } r > 0. \end{cases}$$

where for all  $i \in [r]$ ,  $Y_i$  is a Bernoulli random variable (independent of others) with probability of success  $p$ . Observe that for any configuration  $s$  and any player  $i$  with  $s_i = e$ , we have  $c_i(s) = f_e(s_e)$ .

Defining

$$\Phi(s) = \sum_e \sum_{i=1}^{s_e} f_e(i),$$

it is easy to verify that it is an exact potential function as for any player  $i$  and any two configurations  $s, s'$  such that  $s_{-i} = s'_{-i}$ ,  $s_i = e$  and  $s'_i = e'$

$$\Phi(s) - \Phi(s') = f_e(s_e) - f_{e'}(s_{e'} + 1) = c_i(s) - c_i(s').$$

In order to polynomially compute a PNE, we can simply use a *Greedy Best Response* algorithm. We insert the players in the game, one by one, and the player just inserted does a best response move. Each such move can be computed in time  $O(m + i^2)$ , where  $i$  is the number of players in the game so far, as for each edge  $e$ , the cumulative distribution function of  $D_e(s)$  can be computed via dynamic programming. One can easily verify, by induction, that on any round of this procedure, the players are in a PNE. Consequently, we get a PNE when the procedure terminates. Using memoization to avoid recalculations, the total time needed is  $O(n \cdot m + n^2)$ .  $\square$

**p-Homogeneous Stochastic Players.** In this case, a stochastic game is equivalent to a congestion game on parallel links with player-specific payoffs [63], as the (risk-averse) individual cost of each player in a configuration  $s$  depends only on the link  $e$ , its congestion  $s_e$ , and  $i$ 's confidence level  $\delta_i$ . Thus, we obtain:

**Corollary 13.2.** Congestion Games with  $p$ -Homogeneous Stochastic Players on parallel-link networks admit a PNE. Moreover, a PNE can be computed in polynomial time.

Milchtaich [63] proved that a parallel-link congestion game with general player-specific payoffs may not admit a potential function. In our case however, the players' individual costs are correlated with each other, as for any edge, there is a common distribution on which they depend. Nevertheless, we next show that parallel-link games with  $p$ -homogeneous stochastic players and linear latencies may not admit a potential function.

**Theorem 13.3.** There are Congestion Games with  $p$ -Homogeneous Stochastic Players on parallel-link networks with linear delays that do not admit a potential function.

*Proof.* It suffices to show that there is an infinite improvement cycle, i.e. an infinite sequence of deviations for which each deviating player perceives less cost. We will modify Milchtaich's counter-example ([63]) to fit our case. Since players have the same probability of participation  $p$ , the load on each edge  $e$  that player  $i$  considers is a binomial distribution:  $\sum_{j \neq i: e \in s_j} X_j$ .

Fix  $p = 0.75$ , and consider three edges,  $e_1$ ,  $e_2$  and  $e_3$ , and three players that will deviate, with  $\delta_1 = 0.75$ ,  $\delta_2 = 0.58$  and  $\delta_3 = 0.6$ . Also, assume that there are  $n_1 = 25$  extra players on  $e_1$ ,  $n_2 = 20$  extra players on  $e_2$  and  $n_3 = 9$  extra players on  $e_3$ . The latency functions of the edges are:  $f_1(k) = 3k + 71$ ,  $f_2(k) = 6k + 33$  and  $f_3(k) = 15k + 1$ .

In the following, an infinite better response cycle is described, consisting of six different configurations that interchangeably follow one another:

	$e_1$	$e_2$	$e_3$
i	{1, 2}	{3}	
ii	{1, 2}		{3}
iii	{2}		{1, 3}
iv		{2}	{1, 3}
v		{2, 3}	{1}
vi	{1}	{2, 3}	
	{1, 2}	{3}	

We will only write down (as a 3-dimensional vector, corresponding to players 1, 2 and 3) what load do the three players perceive on the edge they use in each step (excluding themselves):

- i.** (21, 20, 16)
- ii.** (21, 20, 7)
- iii.** (8, 19, 8)
- iv.** (8, 15, 8)
- v.** (8, 16, 16)
- vi.** (20, 16, 16)

The existence of the above infinite improvement cycle forbids the existence of any potential function.  $\square$

**$\delta$ -Homogeneous Stochastic Players.** In this case, players have the same confidence level  $\delta$ , but the participation probability  $p_i$  of each player  $i$  may be different. We next show how to efficiently compute a PNE in parallel-link networks. Specifically, we describe the  $p$ -Decreasing Greedy Best Response algorithm, or  $p$ DGBR in short, and show that it always results in a PNE:

- Sort players in *non-increasing* order of their  $p_i$ 's.
- Insert one player at a time, according to the previous order, to the edge that corresponds to her best response move.
- Repeat until all players are inserted.

**Theorem 13.4.** The **pDGBR** procedure computes a PNE for Congestion Games with Stochastic  $\delta$ -Homogeneous Players on parallel-link networks with general latency functions in time  $O(n \cdot m + n^2)$ .

*Proof.* The proof comes by induction on the number of players. The induction hypothesis is that before the next insertion we are at a PNE.

Assume that we are in the middle of the procedure, in a PNE, and player  $i$  has just chosen edge  $e$ . Players on other edges do not deviate because the only edge changed is  $e$  and it got an extra player. What remains to prove is that players on  $e$  do not deviate.

Let  $k$  be a player on  $e$ , inserted in a previous step ( $p_k \geq p_i$ ). In order to show that  $k$  doesn't deviate, it suffices to show that after step  $i$ , say under configuration  $s$  (with  $s_i = s_k = e$ ), we have that  $c_k(s) \leq c_i(s)$ , as edge  $e$  is a best response strategy for player  $i$  and the cost that  $i$  and  $k$  perceive on any other edge is the same.

Consider  $c_k(s)$  and  $c_i(s)$ . We have:

$$c_k(s) = \min \left\{ t : \Pr[d_e(1 + X_i + \sum_{j \neq i, k: s_j = e} X_j) \leq t] \geq \delta \right\},$$

$$c_i(s) = \min \left\{ t : \Pr[d_e(1 + X_k + \sum_{j \neq i, k: s_j = e} X_j) \leq t] \geq \delta \right\}.$$

Since  $p_k \geq p_i$ , for any  $r \in \mathbb{N}$ :

$$\begin{aligned} \Pr[X_k + \sum_{j \neq i, k: s_j = e} X_j \leq r] &= \Pr[\sum_{j \neq i, k: s_j = e} X_j \leq r] - \Pr[\sum_{j \neq i, k: s_j = e} X_j = r] \cdot p_k \\ &\leq \Pr[\sum_{j \neq i, k: s_j = e} X_j \leq r] - \Pr[\sum_{j \neq i, k: s_j = e} X_j = r] \cdot p_i \\ &= \Pr[X_i + \sum_{j \neq i, k: s_j = e} X_j \leq r]. \end{aligned}$$

Thus, since  $d_e$ 's are non decreasing,

$$\Pr[d_e(1 + X_k + \sum_{j \neq i, k: s_j = e} X_j) \leq d_e(r + 1)] \leq \Pr[d_e(1 + X_i + \sum_{j \neq i, k: s_j = e} X_j) \leq d_e(r + 1)]$$

and so  $c_k(s) \leq c_i(s)$ , as needed.

The total time needed for the procedure is  $O(n \cdot m + n^2)$ , as at each step  $i$ , the computations for the newly inserted player take  $O(m + i^2)$  time and we can use memoization to avoid recalculations.  $\square$

We can also show that games in this class admit a potential function, which can be thought of as a generalized lexicographic potential function in two dimensions.

**Theorem 13.5.** Congestion Games with Stochastic  $\delta$ -Homogeneous Players on parallel-link networks are potential games.

*Proof.* We will define a two dimensional lexicographic potential function. For that, we define, for each edge  $e$  and configuration  $s$ , a two dimensional vector  $v_{e,s}$  and a total order on these vectors. Right after, for  $s$ , we define a vector  $w_s$  that as components has exactly the vectors  $\{v_{e,s}\}_{e \in E}$  ordered increasingly (with the usual vector ordering). Any improvement step that turned the configuration from  $s$  to  $s'$  is such that  $w_s < w_{s'}$ . Any strictly decreasing function on vectors  $w_s$  works as (generalized) potential. Technical details follow.

Let  $c_e(s) = \min \left\{ t : \Pr[d_e(1 + N_e(s)) \leq t] \geq \delta \right\}$  be the *outside  $\delta$ -cost* of edge  $e$  under  $s$ , i.e. the cost that any player not in  $e$  computes for  $e$  when she considers moving to  $e$ . We have

$$c_e(s) = c_i(s_{-i}, e), \quad \forall i : s_i \neq e \quad (13.1)$$

$$c_e(s) \geq c_i(s), \quad \forall i : s_i = e. \quad (13.2)$$

Let  $v_{e,s} = (c_e(s), s_e)$  and consider the standard ordering on these pairs:

- $(x_1, y_1) < (x_2, y_2)$  iff  $x_1 < x_2$  or  $(x_1 = x_2$  and  $y_1 < y_2)$ .
- $(x_1, y_1) = (x_2, y_2)$  iff  $x_1 = x_2$  and  $y_1 = y_2$ .
- $(x_1, y_1) > (x_2, y_2)$  otherwise.

For a configuration  $s$ , let  $w_s$  be the vector that consists of the pairs  $\{v_{e,s}\}_{e \in E}$  in increasing order. We are going to show that after an improving step, the new configuration  $s'$  is such that  $w_s < w_{s'}$ .

Assume that player  $i$  did an improvement step by moving from  $e$  to  $e'$  and let  $s$  be the configuration with  $s_i = e$  and  $s'$  the configuration with  $s'_i = e'$ . Player  $i$  deviated because  $c_i(s) > c_i(s')$ . It is  $c_i(s') = c_i(s_{-i}, e') = c_{e'}(s)$  and, by (13.2),  $c_e(s) \geq c_i(s)$ . So, we get  $c_e(s) > c_{e'}(s)$ , which implies that

$$v_{e',s} < v_{e,s}.$$

Thus, if we consider the coordinates of  $w_s$ , we know that  $v_{e,s}$  is after  $v_{e',s}$  and so in order to show  $w_s < w_{s'}$ , it suffices to show that  $v_{e',s} < v_{e',s'}$  (inequality 13.3) and  $v_{e',s} < v_{e,s'}$  (inequality 13.4).

By the improving step, the only pairs that changed are  $v_{e,s}$  and  $v_{e',s}$ . In fact, it is  $s_e > s'_e$  and  $s_{e'} < s'_{e'}$  and it might be  $c_e(s) > c_e(s')$  or  $c_{e'}(s) < c_{e'}(s')$ . Whichever is the case, we have:

$$v_{e',s} < v_{e',s'} \quad (13.3)$$

Because  $i$  did an improving step to  $e'$  and by  $s_i \neq e'$  and (13.1) we get  $c_i(s) > c_i(s_{-i}, e') = c_{e'}(s)$ . Also, by  $s'_i \neq e$  and (13.1) we get  $c_i(s) = c_i(s'_{-i}, e) = c_e(s')$ . Thus,  $c_{e'}(s) < c_e(s')$  and

$$v_{e',s} < v_{e,s'} \quad (13.4)$$

Let  $\Phi$  be any strictly decreasing function on  $w_s$ . Clearly, for any configuration  $s$ , any edges  $e, e'$  and any player  $i$  it is

$$c_i(s_{-i}, e) - c_i(s_{-i}, e') > 0 \Rightarrow \Phi(s_{-i}, e) - \Phi(s_{-i}, e') > 0$$

and thus  $\Phi$  is a generalized potential.  $\square$

### 13.2.3 Price of Anarchy for Games with Affine Latencies

In Stochastic Congestion Games with Stochastic Players, the *social cost* of a configuration  $s$  is defined as  $C(s) = \mathbf{E}\left[\sum_{i \in N} X_i D_i(s)\right]$ , as this seems to be the most natural generalization of the definition of the Social Cost in standard atomic CGs.

Letting  $o$  denote an optimal configuration, i.e.  $c(o) = \min_s \{C(s)\}$ , the Price of Anarchy is formally defined as  $PoA = \max \left\{ \frac{C(s)}{C(o)} : s \text{ is a PNE} \right\}$ .

In the following we convert  $C(s)$  to a more convenient form and right after we give upper and lower bounds on the PoA for games with affine latency functions as the expected values related to the random distributions  $d_e(N_e(s))$  for general latency functions are hard to handle.

As already noted,  $D_i(s) = D_{s_i}(s)$  with  $X_i = 1$ , and so  $X_i \cdot D_i(s) = X_i \cdot D_{s_i}(s)$ . Thus,

$$C(s) = \mathbf{E}\left[\sum_{i \in N} X_i \cdot D_{s_i}(s)\right] = \sum_e \mathbf{E}[N_e(s) \cdot d_e(N_e(s))].$$

For affine latency functions of the form  $d_e(k) = a_e k + b_e$ , it is

$$C(s) = \sum_e \mathbf{E}[N_e(s) \cdot (a_e N_e(s) + b_e)] = \sum_e [a_e (\mathbf{E}[N_e(s)]^2 + \mathbf{Var}[N_e(s)]) + b_e \mathbf{E}[N_e(s)]].$$

**Theorem 13.6.** Congestion Games with Stochastic Players and affine latency functions on parallel-link networks have  $PoA = O(n)$ .

*Proof.* Let  $d_e(k) = a_e k + b_e$  denote the latency of an edge  $e$ . Two things should be pointed out for the proof.

i) The costs that players perceive on each edge is almost at least as large as it would be if they were considering as load the expectation of other players on each edge plus themselves, i.e.  $c_i(s) \geq a_e \mathbf{E}[\sum_{j: e=s_j} X_j] - a_e + b_e$ , for any  $s$  and  $i : s_i = e$ .

This is the case as, if we assume that edges have affine delay functions,  $d_e(k) = a_e k + b_e$ , then the cost that player  $i$  perceives for edge  $e$  under a configuration  $s$  with  $s_i = e$  is

$$\begin{aligned} c_i(s) &= \min \left\{ t \mid \Pr \left[ d_e \left( 1 + \sum_{j \neq i: e=s_j} X_j \right) \leq t \right] \geq \delta_i \right\} \\ &= \min \left\{ t \mid \Pr \left[ a_e \left( 1 + \sum_{j \neq i: e=s_j} X_j \right) + b_e \leq t \right] \geq \delta_i \right\} \\ &= a_e \left( 1 + \min \left\{ t \mid \Pr \left[ \sum_{j \neq i: e=s_j} X_j \leq t \right] \geq \delta_i \right\} \right) + b_e. \end{aligned}$$

For the median and the mean of the random variable  $\sum_{j \neq i: e=s_j} X_j$  it is (see e.g [80])

$$\left| \mathbf{E} \left[ \sum_{j \neq i: e=s_j} X_j \right] - \min \left\{ t \mid \Pr \left[ \sum_{j \neq i: e=s_j} X_j \leq t \right] \geq 1/2 \right\} \right| \leq 1.$$

Thus, for player  $i : s_i = e$ ,

$$\begin{aligned} c_i(s) &\geq a_e \left( 1 + \min \left\{ t \mid \Pr \left[ \sum_{j \neq i: e=s_j} X_j \leq t \right] \geq 1/2 \right\} \right) + b_e \\ &\geq a_e \mathbf{E} \left[ \sum_{j \neq i: e=s_j} X_j \right] + b_e \geq a_e \mathbf{E} \left[ \sum_{j: e=s_j} X_j \right] - a_e + b_e \end{aligned}$$

ii) At equilibrium, all players on the used edges perceive a cost not greater than  $n(a + b)$ , where  $a + b = \min_e \{a_e + b_e\}$ .

This is the case, or else a player that perceives a greater cost would have an incentive to deviate to the edge  $e$  with  $d_e(k) = ak + b$ .

To prove the theorem, let  $f$  be a Nash equilibrium and  $o$  be an optimal configuration. We wish to bound the cost of  $f$ ,  $C(f)$ , by a factor of the form  $n \cdot C(o)$ .

Denote  $F_e \equiv N_e(f)$  and  $O_e \equiv N_e(o)$ . We have

$$\begin{aligned} C(f) &= \sum_e \left( a_e (\mathbf{E}[F_e]^2 + \mathbf{Var}[F_e]) + b_e \mathbf{E}[F_e] \right) = \sum_e \mathbf{E}[F_e] \left( a_e \mathbf{E}[F_e] + b_e + a_e \frac{\mathbf{Var}[F_e]}{\mathbf{E}[F_e]} \right) \\ &\leq \sum_e \mathbf{E}[F_e] \left( c_{max} + a_e + a_e \frac{\mathbf{Var}[F_e]}{\mathbf{E}[F_e]} \right) \leq 3 \sum_e \mathbf{E}[F_e] c_{max}. \end{aligned}$$

where  $c_{max}$  is the greatest cost that a player perceives under  $f$ . The inequalities follow from point (i) above,  $c_{max} \geq a_e$  for all  $e$  under use and  $\frac{\mathbf{Var}[F_e]}{\mathbf{E}[F_e]} \leq 1$ .

From point (ii) above, with  $a + b = \min_e \{a_e + b_e\}$ , we get that

$$\begin{aligned} C(f) &\leq 3c_{\max} \sum_e \mathbf{E}[F_e] \leq 3n(a + b) \sum_e \mathbf{E}[F_e] = 3n(a + b) \sum_{i \in N} p_i \\ &= 3n(a + b) \sum_e \mathbf{E}[O_e] \leq 3n \sum_e \mathbf{E}[O_e](a_e + b_e) \\ &\leq 3n \sum_e \mathbf{E}[O_e] \left( a_e \frac{\mathbf{E}[O_e]^2 + \mathbf{Var}[O_e]}{\mathbf{E}[O_e]} + b_e \right) = 3nC(o). \end{aligned}$$

The last inequality follows by  $\frac{\mathbf{E}[O_e]^2 + \mathbf{Var}[O_e]}{\mathbf{E}[O_e]} = \frac{\mathbf{E}[O_e^2]}{\mathbf{E}[O_e]} \geq 1$ .  $\square$

Next, we give a class of fully symmetric games with stochastic players, on singleton strategies and linear latency functions, that has  $PoA = \Omega(n)$ .

**Theorem 13.7.** There are Congestion Games with Homogeneous Players that have  $PoA = \Omega(n)$ .

*Proof.* Let  $k \in \mathbb{N}$ . Consider the parallel links game with  $n$  players and  $k + 1$  edges. The first edge,  $e_1$ , has delay function  $d_1(x) = x$  and the others,  $e_2, \dots, e_{k+1}$ , have  $d_j(x) = (n - k)x$ ,  $j = 2, \dots, k + 1$ . Players play with (common) probability  $p$  and are fearful, i.e. all of them have  $\delta = 1$ , and so they consider that all players on their edge use it.

Let  $f$  be the configuration where  $n - k$  players are on  $e_1$  and the other  $k$  players are one on each of the  $k$  remaining edges. This is a PNE, since each player perceives a cost of  $n - k$ .

All edges  $\{e_i\}_{i=1 \dots k+1}$  have  $b_{e_i} = 0$ . So, the social cost of  $f$  is

$$C(f) = \sum_e [a_e(\mathbf{E}[N_e(f)]^2 + \mathbf{Var}[N_e(s)])]$$

For  $e_1$  it is:  $a_{e_1}(\mathbf{E}[N_{e_1}(f)]^2 + \mathbf{Var}[N_{e_1}(s)]) = (n - k)^2 p^2 + (n - k)p(1 - p)$

For all  $e \in \{e_i\}_{i=2 \dots k+1}$  it is:  $a_e(\mathbf{E}[N_e(f)]^2 + \mathbf{Var}[N_e(s)]) = p(n - k)$ .

So

$$C(f) = (n - k)^2 p^2 + (n - k)p(1 - p) + kp(n - k).$$

Now let configuration  $o$  be the one in which every player plays  $e_1$ . It is

$$C(o) = n^2 p^2 + np(1 - p)$$

So, for  $k = \frac{n}{2}$  and  $p = \frac{1}{n}$

$$PoA \geq \frac{C(f)}{C(o)} = \frac{(n - k)^2 p^2 + (n - k)p(1 - p) + kp(n - k)}{n^2 p^2 + np(1 - p)} = \frac{1}{2} + \frac{n - 1}{8 - \frac{4}{n}} = \Omega(n),$$

as needed.  $\square$



## 13.3 Congestion Games with Stochastic Edges

### 13.3.1 The Model

In Congestion Games with Stochastic Edges, players are deterministic, i.e. they always participate in the game and are represented only by their confidence levels  $\delta_i$ . On the other hand, edges have a stochastic behavior. For an edge  $e$ , its latency function is an independent random variable:

$$d_e(k) = \begin{cases} f_e(k), & \text{with probability } 1 - p_e \\ g_e(k), & \text{with probability } p_e. \end{cases}$$

The cost of an edge  $e$  with load  $k$  is:  $X_e(k) = (1 - p_e) \cdot f_e(k) + p_e \cdot g_e(k)$  and the cost of a player  $i$  with strategy  $s_i$ , is the random variable:  $D_i(s) = \sum_{e \in s_i} X_e(s_e)$

The cost that player  $i$  perceives is:  $c_i(s) = \min \left\{ t \mid \Pr [D_i(s) \leq t] \geq \delta_i \right\}$  and the *social cost* of a configuration  $s$  is defined as:  $C(s) = \mathbf{E} \left[ \sum_{i \in N} D_i(s) \right]$ , i.e. similar to the stochastic players case.

**Classes of congestion games.** Here we only define two classes of congestion games with stochastic edges:

- *homogeneous*, where all players have the same  $\delta_i$ 's.
- *heterogeneous*, where players may have different  $\delta_i$ 's.

The class of congestion games with stochastic edges and homogeneous players boils down to the class of potential games, while the class of congestion games with stochastic edges and heterogeneous players boils down to the class of congestion games with *player specific cost functions* ([63]).

### 13.3.2 Stochastic Edges on Parallel Links: Existence and Computation of PNE

In the following, we restrict ourselves to Congestion Games with Stochastic Edges on parallel-link networks, and investigate the existence and the efficient computation of PNE for the two cases considered above.

**Homogeneous Stochastic Players.** If the players are homogeneous, stochastic congestion games on parallel-links are equivalent to standard congestion games on parallel-links (but with possibly different latencies), because the (risk-averse) individual cost of each player in a configuration  $s$  depends only on the link  $e$  and its congestion  $s_e$ .

**Theorem 13.8.** Stochastic Congestion Games with Stochastic Edges and Homogeneous Players on parallel-link networks are potential games. Moreover, a PNE can be computed in time  $O(n \cdot m)$ .

*Proof.* Recall that  $D_i(s) = \sum_{e \in s_i} X_e(s_e)$  and the cost that players perceive is  $c_i(s) = \min \left\{ t \mid \Pr [D_i(s) \leq t] \geq \delta_i \right\}$  and observe that since players have the same  $\delta$ , the cost that any player  $i$  perceives on edge  $e$  when there are  $s_e$  players in total on edge  $e$  is the same for all  $i$ , and equal to:

$$c_e(s_e) = \begin{cases} f_e(s_e), & \text{if } 1 - p_e \geq \delta \\ g_e(s_e), & \text{otherwise} \end{cases}$$

We now define the standard potential function:

$$\Phi(s) = \sum_e \sum_{j=1}^{s_e} c_e(s)$$

It is easy now to verify that the above function is indeed an exact potential function. Observe that there is no restriction for  $p_e, f_e(n)$  and  $g_e(n)$ .

Regarding the computation of a PNE, we can again use a standard *Greedy Best Response* algorithm. We insert the players in the game, one by one, and the player just inserted does a best response move. Since all players perceive the same costs, it is clear that at each step we have a PNE, and so, when the procedure terminates, we are still in a PNE. As for the time needed, at each step the calculation of the best response move takes time  $O(m)$ , and so the total time needed is  $O(n \cdot m)$ .  $\square$

**Heterogeneous Stochastic Players.** In this case, a stochastic game is equivalent to a congestion game on parallel links with player-specific payoffs [63], as the (risk-averse) individual cost of each player in a configuration  $s$  depends only on the link  $e$ , its congestion  $s_e$ , and  $i$ 's confidence level  $\delta_i$ . Thus, we obtain:

**Corollary 13.9.** Congestion Games with Heterogeneous Stochastic Players and Stochastic Edges on parallel-link networks admit a PNE. Moreover, a PNE can be computed in polynomial time.

In ([63]) it is proved that congestion games with player specific payoff functions always possess a PNE. We now prove that the class of Congestion Games with Stochastic Edges does not admit any kind of potential, even if we restrict ourselves to affine latency functions.

**Theorem 13.10.** There is no potential function for the class of Congestion Games with Stochastic Edges and deterministic risk-averse players.

*Proof.* We consider 3 players and 3 links, with the same “failure” probabilities. The latency functions are:

$$f_1(k) = \begin{cases} 3k + 21, & \text{with probability 0.8} \\ 5k + 22, & \text{with probability 0.2} \end{cases}$$

$$f_2(k) = \begin{cases} 6k + 16, & \text{with probability 0.8} \\ 22k + 5, & \text{with probability 0.2} \end{cases}$$

$$f_3(k) = \begin{cases} k + 24, & \text{with probability 0.8} \\ 25k + 1, & \text{with probability 0.2} \end{cases}$$

Players 1 and 2 have confidence level  $\delta_1 = \delta_2 = 0.7$  and player 3 has confidence level  $\delta_3 = 0.9$ . We now construct the following cycle:

$e_1$	$e_2$	$e_3$
{1, 2}	{3}	
{1, 2}		{3}
{2}		{1, 3}
	{2}	{1, 3}
	{2, 3}	{1}
{1}	{2, 3}	
{1, 2}	{3}	

One can verify that this is a better response cycle and thus no potential function exists. □

### 13.3.3 Price of Anarchy

The risk aversion of the players combined with their selfish behavior may give unlimited degradation to the network.

**Theorem 13.11.** There are Stochastic Congestion Games with Stochastic Edges that have unbounded PoA.

*Proof.* We will use a simple network with two parallel edges and two players:

$$f_1(k) = \begin{cases} ak + 1, & \text{with probability } 0.50 + \epsilon \\ Ak + 1, & \text{with probability } 0.50 - \epsilon, \end{cases}$$

$$f_2(k) = 2ak + 1 + \epsilon, \text{ with probability } 1.$$

(Assume that  $\epsilon < 1/2$ .)

Both players have confidence level  $\delta_1 = \delta_2 = \delta = 0.5$ . We assume that  $A > 2a$ . As a result, both players “see” the good part of edge  $e_1$ , and so

they both prefer it. Let  $s = (e_1, e_1)$  be the configuration vector of the PNE. The social cost of  $s$  is  $C(s) = 2[(2a + 1)(0.5 + \epsilon) + (2A + 1)(0.5 - \epsilon)]$ , while an optimal configuration is  $o = (e_2, e_2)$  with social cost  $C(o) = 2(4a + 1 + \epsilon)$ . We have:

$$\begin{aligned}
 PoA &= \frac{C(s)}{C(o)} = \frac{2[(2a + 1)(0.5 + \epsilon) + (2A + 1)(0.5 - \epsilon)]}{2(4a + 1 + \epsilon)} \\
 &= \frac{(2a + 1)(0.5 + \epsilon)}{4a + 1 + \epsilon} + \frac{(2A + 1)(0.5 - \epsilon)}{4a + 1 + \epsilon} \\
 &\geq \frac{(0.5 - \epsilon)(2A + 1)}{4a + 1 + \epsilon} \\
 &\geq \frac{(0.5 - \epsilon)2A}{4a + 1 + \epsilon} \\
 &\geq \frac{(0.5 - \epsilon)A}{2a + 1}
 \end{aligned}$$

Thus,  $PoA \rightarrow \infty$ , if  $\frac{(0.5 - \epsilon)A}{2a + 1} \rightarrow \infty$  (e.g.  $\epsilon < 0.4$  and  $\frac{A}{2a + 1} \rightarrow \infty$ ).

□

## Chapter 14

# Improving Selfish Routing through Risk Aversion

In this chapter, we investigate how and to which extent one can exploit risk-aversion and modify the perceived latencies of the players so that the Price of Anarchy (PoA) wrt. the total latency of the players is improved. The starting point is to introduce some small (and carefully selected) random perturbations to the edge latencies so that the expected latency does not change, but the perceived cost of the players increases, due to risk-aversion. To provide a simple and general theoretical model of this behavior, we introduce  $\gamma$ -modifiable routing games where the latency function of each edge  $e$  can increase from  $\ell_e(x)$  to  $(1 + \gamma_e)\ell_e(x)$ , for some selected  $\gamma_e \in [0, \gamma]$ . For  $\gamma$ -modifiable games in parallel-links and in series-parallel networks, we fully characterize the values of  $\gamma$  for which  $\gamma$ -bounded latency modifications can decrease the PoA to 1. Moreover, we show how to (efficiently) compute a set of  $\gamma$ -bounded latency modifications so that the PoA of the resulting game improves significantly as  $\gamma$  increases. E.g., for linear latencies, the resulting PoA is at most  $\max\{1, (1 - (1 - \gamma)^2/4)^{-1}\}$ . We prove that our PoA analysis is tight, even for two parallel links, and also discuss the difficulty of extending our characterization and our construction to general networks.

### 14.1 Introducing $\gamma$ -modifiable CGs

In order to introduce  $\gamma$ -modifiable CGs, we first discuss how (typically small) random perturbations in the edge latencies can be performed so that the expected latency does not change, but the latency perceived by the players increases, due to risk aversion. E.g., let us consider an edge  $e$

with latency function  $d_e(x)$  where we can increase the latency temporarily up to  $(1 + a_1)d_e(x)$  and decrease it temporarily (and for relatively short time intervals) up to  $(1 - a_2)d_e(x)$ . If we implement the former change with probability  $p_1$  and the latter with probability  $p_2 < 1 - p_1$  (the probabilities here essentially correspond to proportions of time in which  $e$  operates in each state), the latency function of  $e$  in a given time step is a random variable  $\ell_e(x)$  with expectation:

$$\mathbf{E}[\ell_e(x)] = [p_1(1 + a_1) + p_2(1 - a_2) + (1 - p_1 - p_2)]d_e(x)$$

Adjusting  $p_1$  and  $p_2$  (and possibly  $a_1$  and  $a_2$ ) so that  $p_1 a_1 = p_2 a_2$ , we have  $\mathbf{E}[\ell_e(x)] = d_e(x)$ , i.e., for any given flow, the expected delay through  $e$  does not change. On the other hand, if the players are risk-averse and their individual cost is given by an  $(1 - p_1 + \varepsilon)$ -quantile of the delay distribution (e.g., as in [68, 6]), for some  $\varepsilon > 0$ , the latency perceived by the players on  $e$  is  $(1 + a_1)d_e(x)$ . Similarly, if the individual cost of the risk-averse players are given by the expectation plus the standard deviation of the delay distribution (e.g., as in [67]), the latency perceived by the players on  $e$  is  $(1 + \sqrt{p_1 a_1^2 + p_2 a_2^2})d_e(x)$ . In both cases, we can have a significant increase in the latency perceived by the risk-averse players on  $e$ , while the expected latency remains unchanged. A similar result could be achieved with any latency distribution on  $e$  (possibly more sophisticated and with larger support), as long as its expectation is  $d_e(x)$ .

In most practical situations, the increase and, especially, the decrease in the latency functions that can be implemented are bounded (and relatively small). The same is particularly true for the proportion of time in which an edge can operate in an “abnormal” state of increased or decreased latency. Combined with the formula providing the individual cost of the risk-averse players, these factors determine an upper bound  $\gamma_e$  on the multiplicative increase of the latency perceived by the players on each edge  $e$ . Thus, motivated by such considerations, we introduce the so-called  *$\gamma$ -modifiable selfish routing games* as a simple and general abstraction of how one can exploit risk-aversion towards improving the PoA of selfish routing.

**$\gamma$ -Modifiable Routing Games.** A selfish routing game  $\mathcal{G} = (G, d, r)$  is  *$\gamma$ -modifiable* if for each edge  $e \in G$ , we can choose a  $\gamma_e \in [0, \gamma]$  and change the edge latency functions perceived by the players from  $d_e(x)$  to  $(1 + \gamma_e)d_e(x)$  by small random perturbations, as discussed above. Any vector  $\Gamma = (\gamma_e)_{e \in E}$ , where  $\gamma_e \in [0, \gamma]$  for each edge  $e$ , is called a  $\gamma$ -modification of  $\mathcal{G}$ . Given a  $\gamma$ -modification  $\Gamma$ , we let  $\mathcal{G}^\Gamma$  denote the  $\gamma$ -modified routing game  $\mathcal{G}^\Gamma = (G, (1 + \Gamma)d, r)$ , with a latency function  $(1 + \gamma_e)d_e(x)$  on each edge  $e$ , obtained from  $\mathcal{G}$ . To simplify notation, we sometimes write  $G^\Gamma$ , instead of  $\mathcal{G}^\Gamma$ .

Given a flow  $f$ , the latency perceived by the players on a path  $p$  in  $\mathcal{G}^\Gamma$  is calculated wrt the modified latencies and is equal to  $d_p^\Gamma(f) = \sum_{e \in p} (1 + \gamma_e) d_e(f_e)$ <sup>1</sup>. A flow  $f$  is a *Nash flow* for the modified game, if it routes all traffic on minimum perceived latency paths, i.e., if for every path  $p$  with  $f_p > 0$ , and every path  $p'$ ,  $d_{p'}^\Gamma(f) \leq d_p^\Gamma(f)$ . Again, to simplify notation, we usually write  $d_p(f)$ , instead of  $d_p^\Gamma(f)$ , as long as it is clear from the context that the path latencies are wrt. the modified game  $\mathcal{G}^\Gamma$ .

Given a routing game  $\mathcal{G}$ , we say that a flow  $f$  is  $\gamma$ -*enforceable*, or simply *enforceable*, if there exists a  $\gamma$ -modification  $\Gamma$  of  $\mathcal{G}$  such that  $f$  is a Nash flow of  $\mathcal{G}^\Gamma$ .

We always assume that  $\gamma$ -modifications keep the expected latency functions unchanged. Since for any flow  $f$ , the expected latency of any edge  $e$  in  $\mathcal{G}^\Gamma$  is equal to the latency of  $e$  in  $\mathcal{G}$  under  $f$ , the (expected) total latency of  $f$  in both  $\mathcal{G}^\Gamma$  and  $\mathcal{G}$  is equal to  $C(f) = \sum_{e \in E} f_e d_e(f_e)$ . Hence, the optimal flow  $o$  of  $\mathcal{G}$  is also an optimal flow of  $\mathcal{G}^\Gamma$ .

The Price of Anarchy  $\text{PoA}(\mathcal{G}^\Gamma)$  of the modified game  $\mathcal{G}^\Gamma$  is equal to  $C(f)/C(o)$ , where  $f$  is the Nash flow of  $\mathcal{G}^\Gamma$ . For a  $\gamma$ -modifiable game  $\mathcal{G}$ , the Price of Anarchy of  $\mathcal{G}$  under  $\gamma$ -modifications, denoted  $\text{PoA}_\gamma(\mathcal{G})$ , is the best PoA that we can achieve by some  $\gamma$ -modification. Formally,  $\text{PoA}_\gamma(\mathcal{G}) = \min\{\text{PoA}(\mathcal{G}^\Gamma) \mid \Gamma \text{ is a } \gamma\text{-modification of } \mathcal{G}\}$ . For routing games with cost functions in a class  $\mathcal{D}$ ,  $\text{PoA}_\gamma(\mathcal{D})$  denotes the maximum  $\text{PoA}_\gamma(\mathcal{G})$  over all  $\gamma$ -modifiable games  $\mathcal{G}$  with latency functions in class  $\mathcal{D}$ .

**Connection to Marginal-Cost Tolls.** A sufficient condition for the optimal flow to be  $\gamma$ -enforceable can be obtained through optimal marginal-cost tolls, that assign an additive toll of  $o_e d'_e(o_e)$  to any edge  $e$  (see e.g., [77]).

**Proposition 16.** *Let  $o$  be the optimal flow of a  $\gamma$ -modifiable instance  $\mathcal{G}$ . If for all links  $e$  with  $o_e > 0$ ,  $\frac{o_e d'_e(o_e)}{d_e(o_e)} \leq \gamma$ , then  $o$  is  $\gamma$ -enforceable in  $\mathcal{G}$ .*

*Proof.* For each edge  $e$  with  $o_e > 0$  (and thus, with  $d_e(o_e) > 0$ ), we let  $\gamma_e = \frac{o_e d'_e(o_e)}{d_e(o_e)}$ , while for each edge  $e$  with  $o_e = 0$ , we let  $\gamma_e = 0$ . By hypothesis, this defines a  $\gamma$ -modification  $\Gamma$  of  $\mathcal{G}$ . Moreover, if we change the latency functions of  $\mathcal{G}$  from  $d_e(x)$  to  $d_e(x) + x d'_e(x) = (1 + \gamma_e) d_e(x)$ , for all edges  $e$ , [77, Cor. 2.4.6] implies that the optimal flow  $o$  of  $\mathcal{G}$  is a Nash flow of the modified game  $\mathcal{G}^\Gamma$ . □ □

<sup>1</sup>To simplify the model and make it easily applicable to general networks, we make the convenient assumption that the latency modifications (and the resulting individual costs of the players) are separable, although most common notions of individual cost for risk-averse players result in non-separable costs (see e.g., [72, 68, 67, 6], but see also [71], where the simplifying assumption of independence among randomized schedulers of different edges also implies the separability of individual costs). The separable costs assumption only affects the extension of our results to series-parallel networks.

Proposition 16 demonstrates that our approach is applicable to any routing game. Moreover, if  $\mathcal{G}$  has polynomial latency functions of degree  $d$ , then the optimal flow is  $\gamma$ -enforceable for any  $\gamma \geq d$ . However, Proposition 16 only provides a necessary condition and does not fully characterize the class of  $\gamma$ -modifiable routing games for which the optimal flow is enforceable (see also Section 14.2). Thus, we develop, in the next sections, a complete characterization of  $\gamma$ -modifiable routing games in parallel-link and in series-parallel networks with  $\gamma$ -enforceable optimal flows.

## 14.2 Modifying Routing Games in Parallel-Link Networks

We proceed to study  $\gamma$ -modifiable instances in parallel-link networks. We first deal with the question of characterizing the  $\gamma$ -modifiable instances where we can enforce the optimal flow. Then, we provide matching upper and lower bounds on the  $PoA_\gamma$  for  $\gamma$ -modifiable instances where the optimal flow is not enforceable. We also show how to compute  $\gamma$ -modifications that guarantee these  $PoA_\gamma$  bounds.

We note that the converse of Proposition 16 is not necessarily true. E.g., let us consider a  $\frac{1}{2}$ -modifiable instance  $\mathcal{G}$  on 2 parallel links with  $d_1(x) = x$ ,  $d_2(x) = x + 2$  and  $r = 3$ . The optimal flow is  $o = (2, 1)$ , and thus, enforceable in  $\mathcal{G}$ . On the other hand, the ratios of the marginal cost tolls to the optimal latencies are 1 and  $1/4$ , for links 1 and 2, respectively. Hence, Proposition 16 only ensures that the optimal flow is enforceable if  $\mathcal{G}$  is 1-modifiable. Therefore, we proceed to develop a characterization of  $\gamma$ -modifiable games for which the optimal flow is enforceable.

**Theorem 14.1.** Let  $\mathcal{G}$  be a  $\gamma$ -modifiable game on parallel links and let  $o$  be the optimal flow of  $\mathcal{G}$ . The following are equivalent:

- (i)  $o$  is  $\gamma$ -enforceable in  $\mathcal{G}$ .
- (ii) for all links  $e, e' \in E$  with  $o_e > 0$ ,  $d_e(o_e) \leq (1 + \gamma)d_{e'}(o_{e'})$ .

*Proof.* (i)  $\rightarrow$  (ii): Let  $\Gamma = (\gamma_e)_{e \in E}$  be a  $\gamma$ -modification that makes  $o$  the Nash flow of  $\mathcal{G}^\Gamma$  and consider a pair of edges  $e$  and  $e'$ . Assume w.l.o.g. that  $d_{e'}(o_{e'}) \leq d_e(o_e)$  and  $o_e > 0$ . Flow  $o$  is a Nash flow in the modified network and thus  $(1 + \gamma_e)d_e(o_e) \leq (1 + \gamma_{e'})d_{e'}(o_{e'})$  which directly implies

$$d_e(o_e) \leq (1 + \gamma_e)d_e(o_e) \leq (1 + \gamma_{e'})d_{e'}(o_{e'}) \leq (1 + \gamma)d_{e'}(o_{e'})$$

(ii)  $\rightarrow$  (i): Assume that for any pair of edges  $e$  and  $e'$ , if  $o_e > 0$  then  $d_e(o_e) \leq (1 + \gamma)d_{e'}(o_{e'})$ . Let  $d_{max} = \max_e\{d_e(o_e) | o_e > 0\}$  be the maximum cost between all used edges under  $o$ . Assign for each edge  $e$  with  $o_e > 0$ ,



$\gamma_e = \frac{d_{max} - l_e(o_e)}{d_e(o_e)}$ . It is  $\gamma_e \leq \gamma$ , for all  $e$ , as by hypothesis  $d_{max} \leq (1 + \gamma)d_e(o_e)$ , for all  $e$ . Assign for each edge  $e$  with  $o_e = 0$ ,  $\gamma_e = 0$ . Let  $\Gamma = (\gamma_e)_{e \in E}$ . It is  $\forall e : o_e > 0 \Rightarrow (1 + \gamma_e)d_e(o_e) = d_{max}$ . Moreover,  $\forall e' : o_{e'} = 0 \Rightarrow d_{e'}(o_{e'}) \geq d_{max}$  as by (e.g.) corollary 2.4.6 in [77], for an  $e' : o_{e'} = 0$  and an  $e : o_e > 0$  and  $d_e(o_e) = d_{max}$ , it is  $d_{e'}(o_{e'}) \geq d_e(o_e) + o_e d'_e(o_e) \geq d_{max}$ . Thus  $o$  is a Nash flow in  $\mathcal{G}^\Gamma$ .  $\square$

Next, in the following Lemma, for any  $\gamma$ -modifiable instance  $\mathcal{G}$  with optimal solution  $o$ , we prove the existence of a pair  $(f, \Gamma)$  with specific suitable properties. This Lemma is the key both for proving the bound on the  $PoA_\gamma$  and guaranteeing an efficient computation of a pair  $(f, \Gamma)$  that falls in that bound.

**Lemma 14.2.** Let  $\mathcal{G} = (G, d, r)$  be a parallel-links  $\gamma$ -modifiable instance and let  $o$  be the optimal flow of  $\mathcal{G}$ . There is a feasible flow  $f$  and a  $\gamma$ -modification  $\Gamma$  of  $\mathcal{G}$  such that

- i)  $f$  is a Nash flow in  $\mathcal{G}^\Gamma$ .
- ii) for any edge  $e$ : if  $f_e < o_e$  then  $\gamma_e = 0$  and if  $f_e > o_e$  then  $\gamma_e = \gamma$ .

*Proof.* Consider  $\mathcal{G} = (G, d, r)$  and its optimal solution  $o$ . If  $o$  can be  $\gamma$ -enforced, then by definition, there is a  $\gamma$ -modification  $\Gamma$  for which  $o$  is the Nash flow of  $\mathcal{G}^\Gamma$ . Thus for  $f = o$  and the above  $\Gamma$ , the Lemma holds. For all other cases we will use induction on the number of edges in  $G$ .

In the base case of a single edge, under any rate  $r$ ,  $f$  and  $o$  coincide and thus under any modification, the Lemma holds.

For the inductive step let  $e_m$  be a used edge with maximum cost under  $o$ . Remove  $e_m$  from the network, remove the flow through  $e_m$ , i.e.  $o_{e_m}$ , and let the instance  $\mathcal{G}_m = (G_m, d, r' = r - o_e)$  denote the new instance. For  $\mathcal{G}_m$ , by induction hypothesis, the Lemma holds. Thus there is a flow  $f'$  and a  $\gamma$ -modification  $\Gamma' = (\gamma'_e)_{e \in E_m}$  of  $\mathcal{G}_m$  such that: i)  $f'$  is the Nash flow in  $\mathcal{G}_m^{\Gamma'}$ , ii) for any edge  $e$ : if  $f'_e < o'_e$  then  $\gamma'_e = 0$  and if  $f'_e > o'_e$  then  $\gamma'_e = \gamma$ , where  $o'$  is the optimal solution of  $\mathcal{G}_m$ .

Now we will put back edge  $e_m$  and the removed flow. If there is a  $\gamma_{e_m}$  so as  $(1 + \gamma_{e_m})d_{e_m}(o_{e_m}) = L(G_m, (1 + \Gamma')d, r')$  then we can add  $\gamma_{e_m}$  to  $\Gamma'$  and get  $\Gamma$  and the Lemma will hold for  $\mathcal{G}^\Gamma$ , with  $f$  being such that  $f_{e_m} = o_{e_m}$  and  $f_e = f'_e$  for all other edges. Else it should be  $d_{e_m}(o_{e_m}) > L(G_m, (1 + \Gamma')d, r')$  as for any used edge  $e$  under  $f'$ , with  $f'_e < o_e$ , it is  $d_e(f'_e) \leq d_e(o_e) \leq d_{e_m}(o_{e_m})$  and for any used edge  $e'$  with  $f'_{e'} \geq o_{e'}$  it is  $d_{e'}(f'_{e'}) = (1 + \gamma'_{e'})d_{e'}(f'_{e'}) \geq d_{e'}(f'_{e'})$  by properties i) and ii) of the induction hypothesis.

It remains to handle the case  $d_{e_m}(o_{e_m}) > L(G_m, (1 + \Gamma')d, r')$ . Intuitively we will reroute flow from  $e_m$  to the rest of the edges so as the equilibrium property in  $G_m$  is not destroyed. Our final goal is to make  $e_m$  cost equal

to the Nash flow cost of  $G_m$ . During this procedure though, we have to be careful also not to destroy property *ii*). This could happen if we carelessly push flow to edges of  $G_m$  with  $f'_e < o_e$ . To take care of this, while rerouting, if such an edge  $e$  gets flow equal to  $o_e$  we stop rerouting through it but, in order to keep the equilibrium property, we unlock its  $\gamma_e$  and change its value<sup>2</sup> until it becomes  $\gamma$ . It also may be that during this procedure  $e_m$  gets empty of flow but this case is covered by the induction hypothesis for the instance  $(G_m, r)$ . Details follow.

Let  $0 \leq x_m \leq o_{e_m}$  be the maximum value (amount of flow) such that:

(a) there exist a  $\gamma$ -modification  $\Gamma^*$  of  $G_m$  such that under flow  $r' + x$ , the Nash flow  $f^*$  of  $G_m^{\Gamma^*}$  is such that for any edge  $e \in G_m^{\Gamma^*}$ : if  $f'_e \geq o_e$  and  $\gamma'_e = \gamma$  then  $f_e^* \geq f'_e > o_e$  and  $\gamma_e^* = \gamma (= \gamma'_e)$ , if  $f'_e < o_e$  then  $f'_e \leq f_e^* \leq o_e$  and  $\gamma_e^* = 0 (= \gamma_e)$ , if  $f'_e = o_e$  and  $\gamma'_e < \gamma$  then  $f_e^* = o_e (= f'_e)$  and  $\gamma_e^* \leq \gamma_e \leq \gamma$ .

(b)  $d_{e_m}(o_{e_m} - x_m) \geq L(G_m, (1 + \Gamma^*)d, r' + x_m)$

It is  $x_m > 0$ . To see this, let  $E_{lock}$  be the set of edges that have  $f'_e = o_e$  and  $\gamma'_e < \gamma$  and  $E_{free}$  the rest of the used edges under  $f'$ . For  $\epsilon$  small enough, because of continuity, we can reroute flow from  $e_m$  to edges in  $E_{free}$  so as the equilibrium property in  $E_{free}$  is kept, the inequalities of (a) hold and these edges remain in  $E_{free}$ , with the inequality of their new flow with  $o_e$  having the same direction. By continuity and for  $\epsilon$  small enough, we can also grow (until the value  $\gamma$ ) the  $\gamma_e$ 's of the edges in  $E_{lock}$  so as the equilibrium property holds in  $E_{lock}$ . Combining these facts we can reroute an amount of flow  $\epsilon$  from  $e_m$  to edges in  $E_{free}$  and allowably change some of the  $\gamma_e$  values of edges in  $E_{lock}$  so as the equilibrium property in  $G_m$  is kept with inequality (b) still holding (recall that (b) was not tight).

By the same reasoning, unless (b) is tight or  $x_m = o_{e_m}$ , it should be that: (I) for  $x_m$  and its corresponding  $\Gamma^*$  and  $f^*$  there exists an  $e$  such that  $[(f'_e < o_e \text{ and } f_e^* = o_e \text{ and } \gamma_e^* = 0 (= \gamma_e)) \text{ or } (\gamma'_e < \gamma \text{ and } f_e^* = o_e (= f'_e) \text{ and } \gamma_e^* = \gamma)]$ . This means that either an edge in  $E_{free}$  under  $f'$  with  $f'_e < o_e$  will get in  $E_{lock}$  under  $f^*$  by gaining flow or an edge in  $E_{lock}$  under  $f'$  will move to  $E_{free}$  under  $f^*$  by getting  $\gamma_e^* = \gamma$  and having  $f_e^* = o_e$ . Note that an edge  $e \in E_{free}$  with  $f'_e \geq o_e$  and  $\gamma_e^* = \gamma$  cannot get in  $E_{lock}$  under any  $f^*$  that satisfies (a).

If inequality (b) is tight then we first let  $\gamma_{e_m} = 0$  and add it to  $\Gamma^*$  to make a  $\gamma$ -modification  $\Gamma$ . We then let  $f_{e_m} = o_{e_m} - x_m$  and  $f_e = f_e^*$  for all other edges. The pair  $(f, \Gamma)$  satisfies the Lemma. If inequality (b) is not tight but  $x_m = o_{e_m}$ <sup>3</sup>, then we first let  $\gamma_{e_m} = 0$  and add it to  $\Gamma^*$  to make a  $\gamma$ -modification

<sup>2</sup>this doesn't destroy property *ii*), as the flow through  $e$  would be  $o_e$

<sup>3</sup>which implies  $d_{e_m}(0) > L(G_m, (1 + \Gamma^*)d, r)$

$\Gamma$  and then we let  $f_{e_m} = 0$  and  $f_e = f_e^*$ . The pair  $(f, \Gamma)$  satisfies the Lemma.<sup>4</sup>

If inequality (b) is not tight and  $x_m < o_{e_m}$  then set  $f' = f^*$ ,  $o_{e_m} = o_{e_m} - x_m$ ,  $r' = r' + x_m$  and  $\Gamma' = \Gamma^*$  and repeat the procedure.

To complete the proof, it suffices to show that, the above steps are finite and in the final step, inequality (b) holds with equality or  $e_m$  is empty of flow. To see this, first observe that at any step (that ended without (b) being tight and without  $e_m$  being empty of flow), because of (I), the number of edges that have either  $f'_e < o_e$  or ( $f'_e = o_e$  and  $\gamma'_e < \gamma$ ) drops down by at least one. In the worst case, this number will drop down to zero and thus in the next step either (b) will get tight or  $x_m = o_{e_m}$ , as then the rerouting may continue unrestricted.  $\square$

Next we give an upper bound of the  $PoA_\gamma$  of  $\gamma$ -modifiable instances with latency functions in class  $\mathcal{D}$ . The pair  $(f, \Gamma)$  of Lemma 14.2 is used in an analysis similar to [29]. The notable difference comes to the factor  $-\gamma(x - y)d(x)$  that arises in  $\sup_{d \in \mathcal{D}, x \geq y \geq 0} \frac{y(d(x) - d(y)) - \gamma(x - y)d(x)}{xd(x)}$  because of the ability to  $\gamma$ -modify the instances.

**Theorem 14.3.** For  $\gamma$ -modifiable parallel-links instances with cost functions in class  $\mathcal{D}$ , it is

$$PoA_\gamma(\mathcal{D}) \leq \rho_\gamma(\mathcal{D}) = \max \left\{ 1, \frac{1}{1 - \beta_\gamma(\mathcal{D})} \right\},$$

where  $\beta_\gamma(\mathcal{D}) = \sup_{d \in \mathcal{D}, x \geq y \geq 0} \frac{y(d(x) - d(y)) - \gamma(x - y)d(x)}{xd(x)}$

*Proof.* Let  $\mathcal{G} = (G, r)$  be a parallel links instance with cost functions in class  $\mathcal{D}$  and  $o$  be its optimal solution. For  $\mathcal{G}$ , Lemma 14.2 holds. Let  $f$  and  $\Gamma$  be the flow and the  $\gamma$ -modification given by Lemma 14.2. By definition, it is  $PoA_\gamma(\mathcal{G}) \leq PoA(\mathcal{G}^\Gamma)$ . We will bound  $PoA(\mathcal{G}^\Gamma)$ .

Let  $E_{max}^f$  be the set of edges that have  $f_e < o_e$ ,  $E_{min}^f$  be the set of edges that have  $f_e > o_e$  and  $E_{int}^f$  be the set of used edges with  $f_e = o_e$ . Clearly  $E = E_{max}^f \cup E_{min}^f \cup E_{int}^f$

It is  $PoA(\mathcal{G}^\Gamma) = \frac{\sum_{e \in E} f_e d_e(f_e)}{\sum_{e \in E} o_e d_e(o_e)}$ . Using variational inequality and the  $\gamma_e$ 's of  $\Gamma$  (for which we have a Nash flow) we get

$$\begin{aligned} & \sum_{e \in E_{max}^f} f_e d_e(f_e) + \sum_{e \in E_{min}^f} f_e (1 + \gamma) d_e(f_e) + \sum_{e \in E_{int}^f} f_e (1 + \gamma_e) d_e(f_e) \\ & \leq \sum_{e \in E_{max}^f} o_e d_e(f_e) + \sum_{e \in E_{min}^f} o_e (1 + \gamma) d_e(f_e) + \sum_{e \in E_{int}^f} o_e (1 + \gamma_e) d_e(f_e) \end{aligned}$$

<sup>4</sup>induction hypothesis for the instance  $(G_m, r)$  could also be applied

$$\begin{aligned}
& \Downarrow \\
\sum_{e \in E} f_e d_e(f_e) & \leq \sum_{e \in E} o_e d_e(f_e) - \sum_{e \in E_{\min}^f} \gamma(f_e - o_e) d_e(f_e) - \sum_{e \in E_{\text{int}}^f} \gamma_e(f_e - o_e) d_e(f_e) \\
& \leq \sum_{e \in E} o_e (d_e(f_e) - d_e(o_e)) + \sum_{e \in E} o_e d_e(o_e) - \sum_{e \in E_{\min}^f} \gamma(f_e - o_e) d_e(f_e) \\
& \leq \sum_{e \in E} o_e d_e(o_e) + \sum_{e \in E_{\min}^f} (o_e (d_e(f_e) - d_e(o_e)) - \gamma(f_e - o_e) d_e(f_e))
\end{aligned}$$

Setting  $\beta_\gamma(\mathcal{D}) = \sup_{d \in \mathcal{D}, x \geq y \geq 0} \frac{y(d(x)-d(y))-\gamma(x-y)d(x)}{xd(x)}$  we get

$$\begin{aligned}
\sum_{e \in E} f_e d_e(f_e) & \leq \sum_{e \in E} o_e d_e(o_e) + \sum_{e \in E_{\min}^f} \frac{(o_e (d_e(f_e) - d_e(o_e)) - \gamma(f_e - o_e) d_e(f_e)) f_e d_e(f_e)}{f_e d_e(f_e)} \\
& \leq \sum_{e \in E} o_e d_e(o_e) + \beta_\gamma(\mathcal{D}) \sum_{e \in E_{\min}^f} f_e d_e(f_e) \\
& \Downarrow \\
\frac{\sum_{e \in E} f_e d_e(f_e)}{\sum_{e \in E} o_e d_e(o_e)} & \leq \frac{1}{1 - \beta_\gamma(\mathcal{D})} = \rho_\gamma(\mathcal{D})
\end{aligned}$$

Putting everything together, we have

$$PoA_\gamma(\mathcal{G}) \leq PoA(\mathcal{G}^\Gamma) = \frac{\sum_{e \in E} f_e d_e(f_e)}{\sum_{e \in E} o_e d_e(o_e)} \leq \rho_\gamma(\mathcal{D})$$

Thus, for the class of games with latency functions in class  $\mathcal{D}$  it is

$$PoA_\gamma(\mathcal{D}) \leq \rho_\gamma(\mathcal{D})$$

□

Next we give upper bounds for specific classes of  $\gamma$ -modifiable instances.

**Corollary 14.4.** For  $\gamma$ -modifiable instances with degree  $d$  polynomial latency functions

$$PoA = 1, \text{ if } \gamma \geq d \text{ and } PoA \leq \frac{1}{1 - d \left( \frac{\gamma+1}{d+1} \right)^{\frac{d+1}{d}} + \gamma}, \text{ if } \gamma < d$$

*Proof.* Let  $\mathcal{G}$  be a  $\gamma$ -modifiable instance with degree  $d$  polynomial latency functions and let  $o$  be the optimal solution of  $\mathcal{G}$ .

By (e.g.) [77]  $o$  is the Nash flow of a game with the same underlying network and traffic rate  $r$  but cost functions changed from  $d_e(x)$  to  $(xd_e(x))'$ . Thus, for polynomials of degree  $d$ ,  $o$  coincides with the Nash flow of a game with the same underlying network and rate  $r$  but cost functions changed from  $\sum_{i=0}^d a_i x^i$  to  $\sum_{i=0}^d (i+1)a_i x^i$ .

If  $\gamma \geq d$ , it is  $\sum_{i=0}^d (i+1)a_i x^i \leq (\gamma+1) \sum_{i=0}^d a_i x^i$  and thus there exist  $\gamma_e$ 's so as for any edge  $e$   $\sum_{i=0}^d (i+1)a_i o_e^i \leq (1+\gamma_e) \sum_{i=0}^d a_i o_e^i$ , which implies that  $o$  is  $d$ -enforceable.

For  $\gamma < d$  we bound  $\beta_\gamma(\mathcal{D})$ . It is  $\frac{y(d(x)-d(y))-\gamma(x-y)d(x)}{xd(x)} = \frac{y}{x} \left(1 + \gamma - \frac{d(y)}{d(x)}\right) - \gamma$ . For a polynomial of degree  $d$ ,  $d(x) = \sum_{i=0}^d a_i x^i$ , and  $y \leq x$  it is  $\frac{d(y)}{d(x)} \geq \frac{y^d}{x^d}$  as  $y^{d-i} \leq x^{d-i} \Rightarrow \sum a_i y^i x^d \geq \sum a_i x^i y^d$ . Thus  $\frac{y}{x} \left(1 + \gamma - \frac{d(y)}{d(x)}\right) - \gamma \leq \frac{y}{x} \left(1 + \gamma - \frac{y^d}{x^d}\right) - \gamma$ . This quantity is maximized for  $y$  satisfying  $(y^{d+1})' = (1+\gamma)x^d$  which gives  $y = \sqrt[d]{\frac{\gamma+1}{d+1}}x$ ,  $\beta_\gamma(\mathcal{D}) = d \left(\frac{\gamma+1}{d+1}\right)^{\frac{d+1}{d}} - \gamma$  and  $\rho_\gamma(\mathcal{D}) = \frac{1}{1 - d \left(\frac{\gamma+1}{d+1}\right)^{\frac{d+1}{d}} + \gamma}$   $\square$

By setting  $d = 1$  to Corollary 14.4 we bound the price of anarchy for affine latencies.

**Corollary 14.5.** For  $\gamma$ -modifiable instances with affine latencies

$$PoA = 1, \text{ if } \gamma \geq 1 \text{ and } PoA \leq \frac{1}{1 - \frac{(1-\gamma)^2}{4}}, \text{ if } \gamma < 1$$

**Remark 14.6.** Relating  $\rho(\mathcal{D})$  (from [29]) with  $\rho_\gamma(\mathcal{D})$  for the class  $\mathcal{D}$  of affine latencies we get that  $\rho_\gamma(\mathcal{D}) = \frac{1}{1 + \frac{\gamma(2-\gamma)}{3}} \rho(\mathcal{D})$  which drops down quickly as  $\gamma$  grows from 0 to 1.

Next we show that these bounds are essentially tight.

**Theorem 14.7.** For any class of latency functions  $\mathcal{D}$ , and any  $\epsilon > 0$  there is an instance  $\mathcal{G}$  with latency functions in  $\mathcal{D}$  with  $PoA_\gamma(\mathcal{G}) \geq \rho_\gamma(\mathcal{D}) - \epsilon$

*Proof.* Let  $\epsilon > 0$  and consider a  $\gamma$ -modifiable instance  $\mathcal{G}$  of two parallel links,  $e_1$  and  $e_2$ , flow rate  $r$  and cost functions: an arbitrary cost function  $d_1(x) = d_e(x)$  (to be fixed later) in class  $\mathcal{D}$  for link  $e_1$  and the constant function  $d_2(x) = (1+\gamma)d_e(r)$  for link  $e_2$ .

Under any  $\gamma$ -modification  $\Gamma = (\gamma_1, \gamma_2)$ , at Nash flow  $f$  of  $\mathcal{G}^\Gamma$ , all the flow goes through link  $e_1$  and thus  $SC^f = r d_e(r)$ . At optimal flow  $o$ , let  $o_1$  be the flow that goes through link  $e_1$ . It is  $SC^o = (r - o_1)(\gamma + 1)d_e(r) + o_1 d_e(o_1)$  and

$$PoA = \frac{r d_e(r)}{(r - o_1)(\gamma + 1)d_e(r) + o_1 d_e(o_1)} = \frac{1}{1 - \frac{o_1(d_e(r) - d_e(o_1)) - \gamma(r - o_1)d_e(r)}{r d_e(r)}}$$

Flow  $o$  is optimal and thus  $o_1 \in [0, r]$  is exactly the value that minimizes social cost and eventually maximizes  $\frac{rd_\epsilon(r)}{(r-o_1)(\gamma+1)d_\epsilon(r)+o_1d_\epsilon(o_1)}$  and so maximizes

$$\frac{o_1(d_\epsilon(r) - d_\epsilon(o_1)) - \gamma(r - o_1)d_\epsilon(r)}{rd_\epsilon(r)} \quad (14.1)$$

Recall that  $\beta_\gamma(\mathcal{D}) = \sup_{d \in \mathcal{D}, x \geq y \geq 0} \frac{y(d(x)-d(y))-\gamma(x-y)d(x)}{xd(x)}$  and let  $d_\epsilon(x)$  be a cost function such that  $\sup_{x \geq y \geq 0} \frac{y(d_\epsilon(x)-d_\epsilon(y))-\gamma(x-y)d_\epsilon(x)}{xd_\epsilon(x)} \geq \beta_\gamma(\mathcal{D}) - \frac{\epsilon(1-\beta_\gamma(\mathcal{D}))^2}{1-\epsilon(1-\beta_\gamma(\mathcal{D}))}$ . Because  $o_1$  maximizes (14.1), it is  $\frac{o_1(d_\epsilon(r)-d_\epsilon(o_1))-\gamma(r-o_1)d_\epsilon(r)}{rd_\epsilon(r)} \geq \beta_\gamma(\mathcal{D}) - \frac{\epsilon(1-\beta_\gamma(\mathcal{D}))^2}{1-\epsilon(1-\beta_\gamma(\mathcal{D}))}$  and thus

$$PoA \geq \frac{1}{1 - \beta_\gamma(\mathcal{D}) + \frac{\epsilon(1-\beta_\gamma(\mathcal{D}))^2}{1-\epsilon(1-\beta_\gamma(\mathcal{D}))}} = \rho_\gamma(\mathcal{D}) - \epsilon$$

□

Based on Lemma 14.2, we present an algorithmic approach that given a  $\gamma$ -modifiable instance  $\mathcal{G}$  computes a  $\gamma$ -modification  $\Gamma$  such that the Nash flow  $f$  of  $\mathcal{G}^\Gamma$  is such that  $\frac{SC^f}{SC^o} \leq \rho(\mathcal{D})$ , with  $\mathcal{D}$  being the class of latency functions of  $\mathcal{G}$ .

**Lemma 14.8.** Let  $o$  be the optimal flow of a parallel links instance  $\mathcal{G}$ . A flow  $f$  and a  $\gamma$ -modification  $\Gamma$  of  $\mathcal{G}$  with the properties of Lemma 14.2 can be computed in time  $\frac{|E|(|E|+1)}{2} \text{Time}(\text{AlgPar})$ , where  $\text{Time}(\text{AlgPar})$  denotes the time complexity of an algorithm  $\text{AlgPar}$  that computes Nash flows in parallel links networks.

*Proof.* We first compute the optimal solution  $o$  of  $\mathcal{G}$  and delete all unused by  $o$  edges, so we assume that w.l.o.g. all edges of  $G$  are used by  $o$ . Then, we search efficiently in the space of flows for an  $f$  that can be combined with a  $\gamma$ -modification  $\Gamma$  of  $\mathcal{G}$  such that  $f$  and  $\Gamma$  satisfy Lemma 14.2. The key point we use from Lemma 14.2 (and prove later on) is that for the pair  $(f, \Gamma)$  of the proposition, the edges that have  $f_e < o_e$  are the most costly used edges under  $o$  while the edges that have  $f_e > o_e$  are the less costly edges under  $o$ .

In detail, for a combination  $(k, l) : k + l \leq |E|$  find sets  $E_{\max} : |E_{\max}| = k$  and  $E_{\min} : |E_{\min}| = l$  such that  $E_{\max}$  contains the  $k$  most costly edges of  $G$  under  $o$  and  $E_{\min}$  contains the  $l$  less costly edges of  $G$  under  $o$ <sup>5</sup>. Let  $\mathcal{G}'$  be the  $\gamma$ -modifiable instance that has only the edges  $E_{\max}$  and  $E_{\min}$ , traffic rate  $r' = \sum_{e \in E_{\max} \cup E_{\min}} (o_e)$  and the latency functions of edges in  $E_{\min}$  changed from  $d_e(x)$  to  $(1 + \gamma)d_e(x)$ .

<sup>5</sup>so as  $E_{\max} \cap E_{\min} = \emptyset$

For all combinations of  $(k, l) : k + l \leq |E|$ , we compute the Nash flow  $f'$  of  $\mathcal{G}'$ . If  $f'$  is such that (1)  $\forall e \in E_{max} : f'_e \leq o_e$ , (2)  $\forall e \in E_{min} : f'_e \geq o_e$  and (3)  $\forall e \in E \setminus (E_{max} \cup E_{min}) : \frac{1}{1+\gamma}L(\mathcal{G}') \leq d_e(o_e) \leq L(\mathcal{G}')$  then we let for each edge  $e \in E \setminus (E_{max} \cup E_{min})$ ,  $\gamma_e = \frac{L(\mathcal{G}')}{d_e(o_e)} - 1$ . Clearly for any such  $e$  it is  $0 \leq \gamma_e \leq \gamma$ . By setting  $\gamma_e = \gamma$  for all edges in  $E_{min}$  and  $\gamma_e = 0$  for all edges in  $E_{max}$  we get a  $\gamma$ -modification  $\Gamma$  such that the Nash flow  $f$  of  $\mathcal{G}^\Gamma$  satisfies Lemma 14.2 and thus Theorem 14.3 applies.

It remains to show that there is a pair  $(k, l)$  such that (1), (2) and (3) hold. By Lemma 14.2, there is a feasible flow  $f$  and a  $\gamma$ -modification  $\Gamma$  of  $\mathcal{G}$  such that

i)  $f$  is the Nash flow in  $G^\Gamma$ .

ii) for any edge  $e$ : if  $f_e < o_e$  then  $\gamma_e = 0$  and if  $f_e > o_e$  then  $\gamma_e = \gamma$ .

Let  $E_{max} = \{e \in E | f_e < o_e\}$ ,  $E_{min} = \{e \in E | f_e > o_e\}$  and  $E_{int} = \{e \in E | f_e = o_e\}$ . Because  $f$  is a Nash flow in  $G^\Gamma$ , for any  $e_{max} \in E_{max}$ ,  $e_{min} \in E_{min}$ ,  $e_{int} \in E_{int}$  it is  $d_{e_{max}}(f_{e_{max}}) \geq (1 + \gamma_{e_{int}})d_{e_{int}}(f_{e_{int}}) \geq (1 + \gamma)d_{e_{min}}(f_{e_{min}})$ . This, combined to [for  $e \in E_{max}$  it is  $d_e(o_e) \geq d_e(f_e)$ , for  $e \in E_{int}$  it is  $d_e(o_e) = d_e(f_e)$  and for  $e \in E_{min}$  it is  $d_e(o_e) \leq d_e(f_e)$ ] implies that  $E_{max}$  contains the most costly edges under  $o$  and  $E_{min}$  contains the less costly edges under  $o$ . Thus for pair  $(|E_{max}|, |E_{min}|)$ , properties (1), (2) and (3) hold.

Clearly the above procedure needs at most  $\frac{|E|(|E|+1)}{2}$  (possible pairs of  $(k, l)$ ) computations of the Nash flow of  $G'$  under the different flow rates that may arise. Thus the lemma follows.  $\square$

### 14.3 Connection to Routing Games with Restricted Tolls

Bonifaci et al. in [17] studied routing games where along with each edge, an upper bound on the allowable toll on that edge is given. They provide a characterization for the flows that can be imposed by the restricted tolls and compute the optimal tolls when the optimal flow is inducible. We have drawn an iff condition (Theorem 14.1 for parallel links and a similar one for series parallel networks) that better suites our multiplicative approach and is also needed to follow the other results.

Also in [17], based on the previous characterization, they manage to compute the tolls that induce the smallest cost at equilibrium for parallel link networks. Their approach is essentially using a convex programming solver that solves several convex programs. One of these convex programs considers exactly the edges that is used by the best modification. This way though, no information about the nature of the solution is given.

Our approach intuitively applies Karush Kuhn Tucker conditions to the convex program that considers exactly the edges that is used by the

best modification and tries to follow them. It does so, by restricting the  $(f_e, \gamma_e)$  pairs on the edges in a way similar to the restrictions provided by the Karush Kuhn Tucker conditions (Lemma 14.2).

This approach has two major benefits. The first of them is that it relates the complexity of finding a good (wrt PoA bounds)  $\gamma$ -modification to the complexity of finding Nash flows. The second one is that it allows to get a simpler mathematical expression as a bound for the PoA. This expression is both giving a better insight for the improvement that can be achieved via  $\gamma$ -modifications<sup>6</sup> and applies to cases with more general latency functions (for which a tight example is given) than the polynomial latency functions considered in [17]<sup>7</sup>.

As a last positive comment for our work<sup>8</sup>, we point out that by our approach, uncertainty is applied only to edges that intuitively have to get some uncertainty while by the approach of [17] more or less all edges get some uncertainty which is the minimum between their toll bound or their marginal toll. Their derived bounds rely to the fact that in worst case examples there are edges of constant cost that take no toll. Thus in our approach the total amount of uncertainty is kept lower while for cases “away” from the worst case examples our modifications ought to give better improvement results.

## 14.4 Modifying Routing Games in more General Settings

In this section we show a way for generalizing the results of the parallel links case to the case of series parallel networks and to the case of parallel links with heterogeneous players and more general restrictions on the uncertainty added to each edge.

### Series Parallel Networks

The main goal is to get a  $\gamma$ -modification similar to the one of Lemma 14.2 which restricts the pairs  $(f_e, \gamma_e)$  to be such that if  $f_e > o_e$  then  $\gamma_e = \gamma$  and if  $f_e < o_e$  then  $\gamma_e = 0$ . Once such a Lemma is proved, the analysis of the PoA bound of Theorem 14.3 can be applied and a similar Theorem would hold.

<sup>6</sup>compare the PoA bound of  $\gamma$ -modifiable games with our approach, i.e.  $\frac{1}{1-\beta_\gamma(\mathcal{D})}$ , where  $\beta_\gamma(\mathcal{D}) = \sup_{d \in \mathcal{D}, x \geq y \geq 0} \frac{y(d(x)-d(y))-\gamma(x-y)d(x)}{xd(x)}$ , to the PoA bound of standard CGs (without tolls), i.e.  $\frac{1}{1-\beta(\mathcal{D})}$ , where  $\beta(\mathcal{D}) = \sup_{d \in \mathcal{D}, x \geq y \geq 0} \frac{y(d(x)-d(y))}{xd(x)}$ .

<sup>7</sup>for general latency functions the approach of [17] is not guaranteed to give better bounds than the ones without tolls.

<sup>8</sup>for series parallel networks.



To prove such a Lemma, we use induction on the decomposition of the series parallel network. The complicated part of the induction is the parallel composing one. Assuming that for each of the parallel composing networks the induction hypothesis of the lemma holds we start rerouting flow from one network to the other in a careful way so as the properties for the  $(f_e, \gamma_e)$  pairs do not break. The way the rerouting occurs is similar to the rerouting in the parallel links case, i.e. all the  $\gamma_e$ 's are locked and get unlocked only if  $f_e$  gets equal to  $o_e$  during the rerouting which itself reduces the largest fraction of used paths with common ends until it reaches  $\gamma + 1$ .

The constructive nature of this lemma will allow us also to get such a flow in time polynomially related to the time for computing a Nash flow, i.e. an analogue of Lemma 14.8 can be derived. The rerouting procedure will have to stop either to lock or unlock a  $\gamma_e$  of an edge  $e$  or to leave an edge empty of flow. Because each of these incidents may happen only once for each edge, we get that the rerouting will stop at most  $O(|E|)$  number of times. For the exact flow that gets rerouted each time, a binary search in the space of flows has to be made, that calls several times a Nash flow solver, which at the end returns a flow for which one of the above incidents happens.

### Parallel Links with Heterogeneous Players

The main goal is again to get a  $\gamma$ -modification similar to the one of Lemma 14.2. When players are heterogeneous then at equilibrium the more risk averse players get to higher expected cost edges. We assume that the edges are ordered according to their cost under optimal flow.

The new thing with the rerouting when trying to follow the proof of Lemma 14.2 is that it should stop also whenever a type of risk averse players entirely leaves an edge to get to the next one. If during the rerouting this happens, then the rerouting should continue up to that edge until this specific edge gets a cost equal to the cost of the next edge, where the cost is wrt the cost of the less risk averse users on this edge. That will allow the rerouting to continue to the next edges and the new player type to enter the next edge.

To compute such a flow-modification pair, a more sophisticated approach than the homogeneous case is needed. We know that in such a flow-modification pair only some of the highest cost (under optimal flow) edges,  $E_h$ , will get no uncertainty added, only some of the lowest cost (under optimal flow) edges,  $E_l$  will get all the uncertainty they could and all other edges,  $E_i$ , will have  $f_e = o_e$ . For each combination of possible  $(E_h, E_i, E_l)$  triples, we do a binary search to see the amount of flow that will

go through  $E_h$  (which will directly give the amount of flow that goes through  $E_i$ ) in order to have a (Nash flow,  $\gamma$ -modification) pair with the desired properties. For some triples we will have to stop the procedure as there may be no such pair for them, though, because of the previous lemma it ought to be a triple for which such a pair exists and which we eventually will find.

To derive a bound on the PoA we may follow a variational inequality approach, one for each risk aversion type. Then all these variational inequalities can be combined but with the risk averse factor on each edge being the lowest one on that edge. Thus in total a PoA bound (that is in fact tight) similar to Theorem 14.3 can be derived for the smallest risk averse factor among the players.

The above approach was allowing  $\gamma$ -modification on the edges. Another way to see  $\gamma$ -modifications is to allow  $\gamma_e$ 's on the edges so as  $\|(\gamma_e)_{e \in E}\|_\infty \leq \gamma$ . So to generalize the approach we may let  $\gamma_e$ 's to be such that  $\|(\gamma_e)_{e \in E}\|_p \leq \gamma$  for any chosen  $p$ -norm. We then can show that treating such a  $p$ -norm allowable modification as in a  $(\gamma/\sqrt[p]{|E|})$ -modifiable CG, we can derive asymptotically tight results on the improvement of the PoA.

# Chapter 15

## Discussion

In the previous chapters we revealed our tiny contribution in the research arena, concerning Braess Paradox in bottleneck routing games, resolving Braess's paradox in random networks and studying CGs with uncertain delays and risk averse players. Yet, many things are open for research.

### 15.1 Braess' Paradox in Additive Costs Games

Research on Braess's Paradox for additive costs congestion games doesn't have many open fields, as there is a big portion of literature concerning it. One open problem that seems interesting to us is the one arose when resolving the paradox for random graphs.

Recall the steps we followed to establish the approximation algorithm. We first simplified the random instance we were given (the good whp network), then we approximately solved the simplified instance via an algorithm based on an approximate version of Caratheodory's Theorem ([12]) and finally we extended the result to the initial instance. Although the approximation factor relies both on the solution for the simplified instance and on the extension to the initial instance, the most costly part of the running time of the algorithm is the intermediate one where we solved the simplified instance.

To recall the problem see figure 15.1. Given a simplified instance, one should suitably remove some of the internal edges (edges from neighbors of  $s$ ,  $N_s$ , to neighbors of  $t$ ,  $N_t$ ) so as to minimize, under traffic rate  $r$ , the Nash flow cost in the remaining network. Edges adjacent to  $s$  or  $t$  have affine latencies, i.e. of the form  $ax + b$ , while the internal edges have zero latency.

The problem can be formulated as a linear program with linearly com-

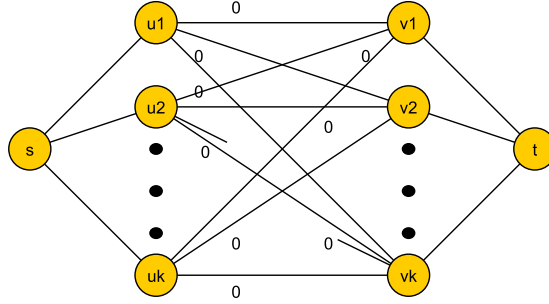

**Figure 15.1:** A simplified network. All edges adjacent to  $s$  or  $t$  have affine latency functions while all other edges, the internal edges, have zero latency

plementarity constraints (lplcc).

$$\begin{aligned}
 & \text{minimize } l \\
 \text{s.t. } & a_i f_i + b_i = l_i \quad \forall i \in N_s \\
 & a_j f_j + b_j = l_j \quad \forall j \in N_t \\
 & \sum_{i \in N_s} f_i = r \\
 & \sum_{j \in N_t} f_j = r \\
 & \sum_{j \in N_t} f_{ij} = f_i \quad \forall i \in N_s \\
 & \sum_{i \in N_s} f_{ij} = f_j \quad \forall j \in N_t \\
 & f_{ij}(l - l_i - l_j) = 0 \\
 & l_i, l_j, f_i, f_j, f_{ij} \geq 0 \quad \forall i \in N_s, \forall j \in N_t
 \end{aligned}$$

Variables  $f_i, f_j, f_{ij}$  correspond to the flow that is routed through the  $i$ -th neighbor of  $s$ ,  $u_i$ , the  $j$ -th neighbor of  $t$ ,  $v_j$ , and edge  $\{u_i, v_j\}$  respectively. Variables  $l_i$  and  $l_j$  correspond to the costs of edges  $\{s, u_i\}$  and  $\{v_j, t\}$  respectively, under flow  $f_i$  and  $f_j$  respectively. Variable  $f_{ij}$  corresponds to the flow through edge  $\{u_i, v_j\}$ .

The first two constraints capture the relation between the flow routed through edges neighboring to  $s$  or  $t$  and their corresponding costs. The next four constraints model flow conservation. The complementarity constraint ensures that if a path  $s - u_i - v_j - t$  takes a positive flow, i.e.  $f_{ij} > 0$ , then its cost is  $l$ . If  $f_{ij} = 0$  then we do not care about  $l_i + l_j = l$  as we can remove edge  $\{u_i, v_j\}$  in the subnetwork.

This formulation seems to tightly capture the problem. Solving general lplcc's is NP-hard but this case is not exactly of the form proved to be NP-hard as  $l - l_i - l_j$  need not be non negative and also a feasible solution can be easily found (the equilibrium of the initial network satisfies the restrictions). Additionally, the size of the intermediate network, or more precisely, the many, long and correlated paths between  $s$  and  $t$ , is a key factor in the

*NP*-hardness reduction of [78]. Thus the complexity of finding the best subnetwork in simplified networks, even for linear latencies, remains well open (as far as we know) and seems quite intriguing.

## 15.2 Braess' Paradox in Bottleneck Costs Games

As we earlier saw, the inapproximability results of [52] did not really shed light on the approximability of the (simple, non-selective) network design problem in the simplest, and most interesting, setting of non-atomic bottleneck routing games with a common origin-destination pair for all players. In our work, concerning the paradox in bottleneck costs games, we followed this direction and managed to prove strong *NP* hardness results for detecting the paradox and approximating the best subnetwork.

In the model we studied, the players were considering the bottleneck cost of their paths and the social cost function was equal to the bottleneck cost of the network. Yet, there is another interesting variant of bottleneck games where the social cost is the average (instead of the maximum) bottleneck cost of the players, studied by Cole, Dodis, and Roughgarden [27] and subsequently by Mazalov et al. [62]. For this variant of non-atomic bottleneck congestion games, as far as we know, neither the problem of detecting the paradox nor the one of finding the best subnetwork has been studied. It feels like the techniques similar to the ones presented here could be used to prove results on these problems that seem to lay in between the problems for additive costs congestion games and the problems for bottleneck costs games with social cost function equal to the maximum congestion.

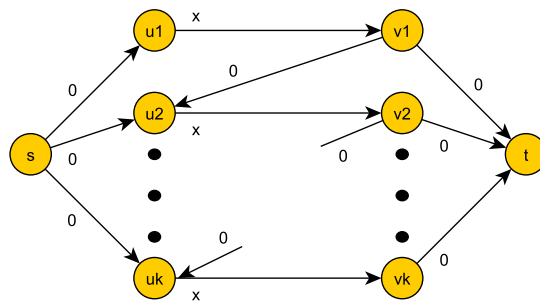

**Figure 15.2:** A network with  $\Theta(n)$  PoA. Optimally all the flow is splitted equally to the  $k$  direct paths while a bad Nash flow routes the traffic through path  $s - u_1 - v_1 - u_2 - v_2 - \dots - u_k - v_k - t$

Another research goal could be to derive results on the existence of

the paradox in random graphs under bottleneck costs. The analog of the additive costs case, i.e. to study random  $\mathcal{G}_{n,p}$ 's could be a first goal. The intuition suggests that a proof of existence of the paradox in random bottleneck costs networks should not be hard and that is because an analog of the bad example's "backedges" (edges going in "opposite" direction, from neighbors of  $t$  to neighbors of  $s$ ) e.g. in [27] or figure 15.2 can probably be easily found in many models of random networks. In a bad Nash flow these backedges are used by the players in sequence and thus all paths from  $s$  to  $t$  cost much and the network behaves bad.

In addition to these, one could try using the techniques we used for exploiting the paradox in random graphs under additive costs so as to exploit the paradox. If specific expansion properties for the random graph models hold then this goal seems tractable and would be of interest.

### 15.3 Stochastic Congestion Games

While the above problems seem quite interesting, our focus is turned to stochastic congestion games and risk averse players. The natural models we proposed for the study of risk aversion under stochastic delays do not seem to easily "cooperate" with networks other than parallel links. This is not a problem that arises only in our models. The players' cost functions used in both models, do not have the property of being the sum of the costs of the edges on the players' paths, i.e. the costs are non-separable, and examining games with non separable costs is not an easy task. An interesting task would be to formulate players' behaviors in a "network familiar" way so as to be able to draw meaningful results for these games in general networks.

Staying in our model though still has some intriguing open problems. One of them is whether games with heterogeneous stochastic players admit an equilibrium. Our intuition is not clear. Another problem is to examine the case of games with stochastic edges and derive results on the existence of equilibrium and potential functions when networks are layered, with the basic property that all  $s - t$  paths have the same length. In this case the paths' costs might be separable and we would be able to draw meaningful results for networks different from parallel links.

## 15.4 Abusing Uncertainty

In the direction of abusing uncertainty, we saw that when risk averse players act under uncertainty, a large portion of them might prefer choosing heavy in expectation but low variance links rather than light in expectation but high variance links. Adding some uncertainty to the network could help in improving its behavior. The results presented here hold for special cases of networks and homogeneous risk averse users.

There are two main open problems in this field. One is how can heterogeneity in the players risk aversion help in improving the network's performance. In this direction we have (almost) proved that heterogeneity can also help in improving the network's performance, yet in the worst case the improvement is similar to the one achieved when players are homogeneous.

The second and probably more interesting problem is how can we abuse uncertainty in more general networks under natural player's risk averse cost functions and draw meaningful results on improving the price of anarchy. When trying to analyze such cases the problem of non separable costs arises once more requiring risk averse cost functions that are both network familiar and capturing the averse behavior of the players.





## Bibliography

- [1] Heiner Ackermann, Heiko Röglin, and Berthold Vöcking, *On the impact of combinatorial structure on congestion games.*, 47th Annual IEEE Symposium on Foundations of Computer Science (FOCS 2006), 2006.
- [2] ———, *Pure nash equilibria in player-specific and weighted congestion games.*, WINE (Paul G. Spirakis, Marios Mavronicolas, and Spyros C. Kontogiannis, eds.), Lecture Notes in Computer Science, vol. 4286, Springer, 2006, pp. 50–61.
- [3] Heiner Ackermann and Alexander Skopalik, *Complexity of pure nash equilibria in player-specific network congestion games.*, Internet Mathematics **5** (2008), no. 4, 323–342.
- [4] Sebastian Aland, Dominic Dumrauf, Martin Gairing, Burkhard Monien, and Florian Schoppmann, *Exact price of anarchy for polynomial congestion games*, STACS, 2006, pp. 218–229.
- [5] Ingo Althöfer, *On sparse approximations to randomized strategies and convex combinations*, Linear Algebra and Applications **99** (1994), 339–355.
- [6] H. Angelidakis, D. Fotakis, and T. Lianas, *Stochastic congestion games with risk-averse players*, Proc. of the 6th International Symposium on Algorithmic Game Theory (SAGT '13), LNCS, vol. 8146, 2013, pp. 86–97.
- [7] Itai Ashlagi, Dov Monderer, and Moshe Tennenholtz, *Resource selection games with unknown number of players*, Proc. of the 5th International Conference on Autonomous Agents and Multiagent Systems (AAMAS 06), 2006, pp. 819–825.
- [8] Baruch Awerbuch, Yossi Azar, and Amir Epstein, *The price of routing unsplittable flow*, Proceedings of the Thirty-seventh Annual ACM

- Symposium on Theory of Computing (New York, NY, USA), STOC '05, ACM, 2005, pp. 57–66.
- [9] Baruch Awerbuch, Yossi Azar, Amir Epstein, Vahab S. Mirrokni, and Alexander Skopalik, *Fast convergence to nearly optimal solutions in potential games.*, ACM Conference on Electronic Commerce (Lance Fortnow, John Riedl, and Tuomas Sandholm, eds.), ACM, 2008, pp. 264–273.
- [10] Yossi Azar and Amir Epstein, *The hardness of network design for unsplittable flow with selfish users*, Proc. of the 3rd Workshop on Approximation and Online Algorithms (WAOA '05), LNCS, vol. 3879, 2005, pp. 41–54.
- [11] Ron Banner and Ariel Orda, *Bottleneck routing games in communication networks*, IEEE Journal on Selected Areas in Communications **25** (2007), no. 6, 1173–1179.
- [12] Siddharth Barman, *Approximating carathéodory's theorem and nash equilibria*, CoRR **abs/1406.2296** (2014).
- [13] Martin Beckmann, C.B. McGuire, and Christopher B. Winsten, *Studies in the economics of transportation*, Yale University Press, New Haven (1956).
- [14] Kshipra Bhawalkar, Martin Gairing, and Tim Roughgarden, *Weighted congestion games: Price of anarchy, universal worst-case examples, and tightness.*, ESA (2) (Mark de Berg and Ulrich Meyer, eds.), Lecture Notes in Computer Science, vol. 6347, Springer, 2010, pp. 17–28.
- [15] Béla Bollobás, *Random Graphs, 2nd Ed.*, Cambridge Studies in Advanced Mathematics, no. 73, Cambridge University Press, 2001.
- [16] Vincenzo Bonifaci, Tobias Harks, and Guido Schäfer, *Stackelberg routing in arbitrary networks*, Math. Oper. Res. **35** (2010), no. 2, 330–346.
- [17] Vincenzo Bonifaci, Mahyar Salek, and Guido Schäfer, *Efficiency of restricted tolls in non-atomic network routing games*, Proceedings of the 4th International Conference on Algorithmic Game Theory (Berlin, Heidelberg), SAGT'11, Springer-Verlag, 2011, pp. 302–313.
- [18] Costas Busch and Malik Magdon-Ismail, *Atomic routing games on maximum congestion*, **410** (2009), 3337–3347.

- [19] Ioannis Caragiannis, Clemente Galdi, and Christos Kaklamanis, *Network load games*, Proc. of the 16th Symposium on Algorithms and Computation (ISAAC '05), LNCS, vol. 3827, 2005, pp. 809–818.
- [20] Ioannis Caragiannis, Christos Kaklamanis, and Panagiotis Kanellopoulos, *Taxes for linear atomic congestion games*, ESA (Yossi Azar and Thomas Erlebach, eds.), Lecture Notes in Computer Science, vol. 4168, Springer, 2006, pp. 184–195.
- [21] Steve Chien and Alistair Sinclair, *Convergence to approximate nash equilibria in congestion games*, Proceedings of the Eighteenth Annual ACM-SIAM Symposium on Discrete Algorithms (Philadelphia, PA, USA), SODA '07, Society for Industrial and Applied Mathematics, 2007, pp. 169–178.
- [22] George Christodoulou and Elias Koutsoupias, *On the price of anarchy and stability of correlated equilibria of linear congestion games*, Proceedings of the 13th Annual European Conference on Algorithms (Berlin, Heidelberg), ESA05, Springer-Verlag, 2005, pp. 59–70.
- [23] George Christodoulou and Elias Koutsoupias, *The price of anarchy of finite congestion games*, Proceedings of the Thirty-seventh Annual ACM Symposium on Theory of Computing (New York, NY, USA), STOC '05, ACM, 2005, pp. 67–73.
- [24] Fan Chung and Stephen J. Young, *Braess's paradox in large sparse graphs*, WINE (Amin Saberi, ed.), Lecture Notes in Computer Science, vol. 6484, Springer, 2010, pp. 194–208.
- [25] Fan Chung, Stephen J. Young, and Wenbo Zhao, *Braess's paradox in expanders*, Random Struct. Algorithms **41** (2012), no. 4, 451–468.
- [26] Richard Cole, Yevgeniy Dodis, and Tim Roughgarden, *Pricing network edges for heterogeneous selfish users*, STOC, ACM, 2003, pp. 521–530.
- [27] ———, *Bottleneck links, variable demand, and the tragedy of the commons*, 2006, pp. 668–677.
- [28] José R. Correa, Andreas S. Schulz, and Nicolás E. Stier Moses, *Selfish routing in capacitated networks*, Math. Oper. Res. **29** (2004), no. 4, 961–976.
- [29] J.R. Correa, A.S. Schulz, and Nicolás Stier Moses, *Selfish Routing in Capacitated Networks*, Mathematics of Operations Research **29** (2004), no. 4, 961–976.

- [30] Juliane Dunkel and Andreas S. Schulz, *On the complexity of pure-strategy nash equilibria in congestion and local-effect games*, In Proc. of the 2nd Int. Workshop on Internet and Network Economics (WINE, Springer Verlag, 2006, pp. 62–73.
- [31] Amir Epstein, Michal Feldman, and Yishay Mansour, *Efficient graph topologies in network routing games*, Games and Economic Behaviour **66** (2009), no. 1, 115–125.
- [32] Eyal Even-dar, Alex Kesselman, and Yishay Mansour, *Convergence time to nash equilibria*, In ICALP, Springer-Verlag, 2003, pp. 502–513.
- [33] Alex Fabrikant, Christos Papadimitriou, and Kunal Talwar, *The complexity of pure nash equilibria*, ACM Press, 2004, pp. 604–612.
- [34] Amos Fiat and Christos H. Papadimitriou, *When the players are not expectation maximizers*, Proc. of the 3th International Symposium on Algorithmic Game Theory (SAGT '10), LNCS, vol. 6386, 2010, pp. 1–14.
- [35] L. Fleischer, K. Jain, and M. Mahdian, *Tolls for Heterogeneous Selfish Users in Multicommodity Networks and Generalized Congestion Games*, 2004, pp. 277–285.
- [36] Lisa Fleischer, Kamal Jain, and Mohammad Mahdian, *Tolls for heterogeneous selfish users in multicommodity networks and generalized congestion games*, FOCS, IEEE Computer Society, 2004, pp. 277–285.
- [37] Steven Fortune, John E. Hopcroft, and James Wyllie, *The directed subgraph homeomorphism problem*, Theor. Comput. Sci. **10** (1980), 111–121.
- [38] Dimitris Fotakis, *Stackelberg strategies for atomic congestion games*, ESA (Lars Arge, Michael Hoffmann, and Emo Welzl, eds.), Lecture Notes in Computer Science, vol. 4698, Springer, 2007, pp. 299–310.
- [39] ———, *Congestion games with linearly independent paths: Convergence time and price of anarchy*, Theory of Computing Systems **47** (2010), no. 1, 113–136.
- [40] Dimitris Fotakis, Alexis C. Kaporis, Thanasis Lianeas, and Paul G. Spirakis, *Resolving braess's paradox in random networks*, WINE (Yiling Chen and Nicole Immorlica, eds.), Lecture Notes in Computer Science, vol. 8289, Springer, 2013, pp. 188–201.

- [41] ———, *On the hardness of network design for bottleneck routing games*, Theor. Comput. Sci. **521** (2014), 107–122.
- [42] Dimitris Fotakis, Alexis C. Kaporis, and Paul G. Spirakis, *Efficient methods for selfish network design*, Proc. of the 36th Colloquium on Automata, Languages and Programming (ICALP-C '09), LNCS, vol. 5556, 2009, pp. 459–471.
- [43] Dimitris Fotakis, George Karakostas, and Stavros G. Kolliopoulos, *On the existence of optimal taxes for network congestion games with heterogeneous users*, SAGT (Spyros C. Kontogiannis, Elias Koutsoupias, and Paul G. Spirakis, eds.), Lecture Notes in Computer Science, vol. 6386, Springer, 2010, pp. 162–173.
- [44] Dimitris Fotakis, Spyros Kontogiannis, and Paul G. Spirakis, *Selfish Unsplittable Flows*, Theoretical Computer Science **348** (2005), 226–239.
- [45] Dimitris Fotakis and Paul G. Spirakis, *Cost-balancing tolls for atomic network congestion games*, WINE (Xiaotie Deng and Fan Chung Graham, eds.), Lecture Notes in Computer Science, vol. 4858, Springer, 2007, pp. 179–190.
- [46] Martin Gairing and Max Klimm, *Congestion games with player-specific costs revisited.*, SAGT (Berthold Vocking, ed.), Lecture Notes in Computer Science, vol. 8146, Springer, 2013, pp. 98–109.
- [47] Fan Chung Graham, Stephen J. Young, and Wenbo Zhao, *Braess's paradox in expanders*, Random Struct. Algorithms **41** (2012), no. 4, 451–468.
- [48] Torben Hagerup and Christine Rüb, *A guided tour of chernoff bounds*, Inf. Process. Lett. **33** (1990), no. 6, 305–308.
- [49] Michael A. Hall, *Properties of the equilibrium state in transportation networks*, Transportation Sci. **12(3)** (1978), 208–216.
- [50] Tobias Harks and Max Klimm, *On the existence of pure nash equilibria in weighted congestion games*, Mathematics of Operations Research **37** (2012), no. 3, 419–436.
- [51] Martin Hoefer, Lars Olbrich, and Alexander Skopalik, *Taxing sub-networks.*, WINE (Christos H. Papadimitriou and Shuzhong Zhang, eds.), Lecture Notes in Computer Science, vol. 5385, Springer, 2008, pp. 286–294.

- [52] Haiyang Hou and Guochuan Zhang, *The hardness of selective network design for bottleneck routing games*, Proc. of the 4th Conference on Theory and Applications of Models of Computation (TAMC '07), LNCS, vol. 4484, 2007, pp. 58–66.
- [53] Tomas Jelinek, Marcus Klaas, and Guido Schäfer, *Computing Optimal Tolls with Arc Restrictions and Heterogeneous Players*, 31st International Symposium on Theoretical Aspects of Computer Science (STACS 2014) (Dagstuhl, Germany) (Ernst W. Mayr and Natacha Portier, eds.), Leibniz International Proceedings in Informatics (LIPIcs), vol. 25, Schloss Dagstuhl–Leibniz-Zentrum fuer Informatik, 2014, pp. 433–444.
- [54] George Karakostas, *Edge pricing of multicommodity networks for heterogeneous selfish users*, In Proceedings of the 45th Annual Symposium on Foundations of Computer Science (FOCS, Press, 2004, pp. 268–276.
- [55] George Karakostas and Stavros G. Kolliopoulos, *The Efficiency of Optimal Taxes*, Proc. of the 1st Workshop on Combinatorial and Algorithmic Aspects of Networking (CAAN '04), LNCS, vol. 3405, 2005, pp. 3–12.
- [56] Frank Kelly, *The mathematics of traffic in networks*, In *The Princeton Companion to Mathematics* (Editors: T. Gowers, J. Green and I. Leader). Princeton University Press, 2008.
- [57] Elias Koutsoupias and Christos Papadimitriou, *Worst-case equilibria*, *STACS 1563 (1999)*, 404–413.
- [58] Henry Lin, Tim Roughgarden, Éva Tardos, and Asher Walkover, *Braess's Paradox, Fibonacci Numbers, and Exponential Inapproximability*, LNCS, vol. 3580, 2005, pp. 497–512.
- [59] Henry Lin, Tim Roughgarden, and Éva Tardos, *A stronger bound on braess's paradox*, *Proceedings of the Fifteenth Annual ACM-SIAM Symposium on Discrete Algorithms (Philadelphia, PA, USA)*, SODA '04, Society for Industrial and Applied Mathematics, 2004, pp. 340–341.
- [60] Richard J. Lipton and Neal E. Young, *Simple strategies for large zero-sum games with applications to complexity theory*, *Proceedings of the Twenty-Sixth Annual ACM Symposium on Theory of Computing*, 23–25 May 1994, Montréal, Québec, Canada, 1994, pp. 734–740.

- [61] Mavronicolas, Marios, Milchtaich, Igal, Monien, Burkhard, Tiemann, and Karsten, *Congestion games with player-specific constants.*, *MFCS (Ludek Kucera and Antonin Kucera, eds.), Lecture Notes in Computer Science*, vol. 4708, Springer, 2007, pp. 633-644.
- [62] Vladimir Mazalov, Burkhard Monien, Florian Schoppmann, and Karsten Tiemann, *Wardrop equilibria and price of stability for bottleneck games with splittable traffic*, *LNCS*, vol. 4286, 2006, pp. 331-342.
- [63] Igal Milchtaich, *Congestion Games with Player-Specific Payoff Functions*, *Games and Economic Behavior* **13** (1996), 111-124.
- [64] \_\_\_\_\_, *Network topology and the efficiency of equilibrium*, *Games and Economic Behavior* **57** (2006), 321-346.
- [65] \_\_\_\_\_, *Network topology and equilibrium existence in weighted network congestion games*, 2009.
- [66] Dov Monderer and Lloyd Shapley, *Potential Games*, *Games and Economic Behavior* **14** (1996), 124-143.
- [67] Evdokia Nikolova and Nicolás Stier Moses, *Stochastic selfish routing*, *Proc. of the 4th International Symposium on Algorithmic Game Theory (SAGT '11)*, *LNCS*, vol. 6982, 2011, pp. 314-325.
- [68] Fernando Ordóñez and Nicolás Stier Moses, *Wardrop equilibria with risk-averse users*, *Transportation Science* **44** (2010), no. 1, 63-86.
- [69] Panagiota N. Panagopoulou and Paul G. Spirakis, *Algorithms for pure nash equilibria in weighted congestion games.*, *ACM Journal of Experimental Algorithmics* **11** (2006).
- [70] Arthur C. Pigou, *The economics of welfare*, Macmillan, 1924.
- [71] Georgios Piliouras, Evdokia Nikolova, and Jeff S. Shamma, *Risk sensitivity of price of anarchy under uncertainty*, *Proceedings of the Fourteenth ACM Conference on Electronic Commerce (New York, NY, USA), EC '13*, ACM, 2013, pp. 715-732.
- [72] R. Tyrell Rockafellar, *Coherent Approaches to Risk in Optimization Under Uncertainty*, *Tutorials in Operations Research* (2007), 38-61.
- [73] Robert W. Rosenthal, *A class of games possessing pure-strategy nash equilibria*, *International Journal of Game Theory* (1973), no. 2, 65-67.

- [74] Tim Roughgarden, *The price of anarchy is independent of the network topology*, *J. Comput. Syst. Sci.* **67** (2003), no. 2, 341-364.
- [75] ———, *Stackelberg scheduling strategies*, *SIAM J. Comput.* **33** (2004), no. 2, 332-350.
- [76] ———, *Selfish routing and the Price of Anarchy*, MIT press, 2005.
- [77] ———, *Selfish Routing and the Price of Anarchy*, MIT press, 2005.
- [78] ———, *On the severity of braess's paradox: Designing networks for selfish users is hard*, *J. Comput. Syst. Sci.* **72** (2006), no. 5, 922-953.
- [79] ———, *Intrinsic robustness of the price of anarchy*, *Proceedings of the 41st Annual ACM Symposium on Theory of Computing (New York, NY, USA), STOC '09*, ACM, 2009, pp. 513-522.
- [80] Alan Siegel, *Median bounds and their application*, 1999, pp. 776-785.
- [81] Alexander Skopalik and Berthold Vöcking, *Inapproximability of pure nash equilibria*, IN *PROCEEDINGS OF THE 40TH ANNUAL ACM SYMPOSIUM ON THEORY OF COMPUTING (STOC, 2008)*, pp. 355-364.
- [82] Chaitanya Swamy, *The effectiveness of stackelberg strategies and tolls for network congestion games*, *SODA (Nikhil Bansal, Kirk Pruhs, and Clifford Stein, eds.)*, SIAM, 2007, pp. 1133-1142.
- [83] Amos Tversky and Daniel Kahneman, *Prospect theory: An analysis of decision under risk*, *Econometrica* **47** (1979), no. 2, 263-291.
- [84] Gregory Valiant and Tim Roughgarden, *Braess's paradox in large random graphs*, *Random Struct. Algorithms. (Preliminary version in Proc. of EC'06)* **37** (2010), no. 4, 495-515.
- [85] László A. Végh, *Strongly polynomial algorithm for a class of minimum-cost flow problems with separable convex objectives*, *Proceedings of the Forty-fourth Annual ACM Symposium on Theory of Computing, STOC '12*, 2012, pp. 27-40.
- [86] Hai Yang and Hai-Jun Huang, *The multi-class, multi-criteria traffic network equilibrium and systems optimum problem*, *Transportation Research* **38** (2004), 1-15.



## List of Figures

1.1	Χάρτης Δικτυακών Παιγνίων Συμφορησης . . . . .	34
1.2	Το Παράδοξο σε Παίγνια με Προσθετικά Πόση . . . . .	42
1.3	Το Παράδοξο σε Παίγνια με Κόστη Συγκέντρωσης . . . . .	44
2.1	Τοποθέτηση στο Χάρτη του Αποτελέσματός μας για τα Παίγνια με Κόστη Συγκέντρωσης . . . . .	51
2.2	Η Τοποθέτηση των Τυχαίων Παιγνίων που Εξετάζονται . . . . .	53
2.3	Τα Στοχαστικά Μοντέλα και η Θέση τους στο Χάρτη Παιγνίων Συμφορησης . . . . .	56
4.1	The network of the reduction and the YES instance case . . . . .	73
4.2	Possible subnetworks of a NO instance . . . . .	75
4.3	The gap amplification's network and the Yes instance case . . . . .	78
4.4	Subnetworks of the gap amplification network in a No instance . . . . .	82
5.1	Braess Paradox in additive costs CGs revisited . . . . .	92
5.2	Eliminating the "cycles" of a best subnetwork . . . . .	98
8.1	Network Congestion Games (small) map . . . . .	144
8.2	Braess's Paradox in Additive Costs Congestion Games . . . . .	153
8.3	Braess's Paradox in Bottleneck Costs Congestion Games . . . . .	155
9.1	Placement on the CGs' map of our work on Bottleneck Games . . . . .	160
9.2	The placement for the Random Networks under study . . . . .	162
9.3	The Stochastic Models and their positioning on CGs' map . . . . .	165
11.1	The network of the reduction and the YES instance case . . . . .	183
11.2	Possible subnetworks of a NO instance . . . . .	184
11.3	The gap amplification's network and the Yes instance case . . . . .	187
11.4	Subnetworks of the gap amplification network in a No instance . . . . .	192
12.1	Braess Paradox in additive costs CGs revisited . . . . .	202
12.2	Eliminating the "cycles" of a best subnetwork . . . . .	208

15.1 0-simplified network with unknown BestSub's complexity .	252
15.2A worst case PoA network for Bottleneck CGs . . . . .	253



