

**Diese Arbeit wurde vorgelegt am Lehrstuhl für Systemverfahrenstechnik**  
The present work was submitted to Chair of Process Systems Engineering

Conceptual design for an early stage process analysis of reaction and separation processes in future biorefineries

Masterthesis

presented by  
Michail Rekkas Ventiris  
353124

Aachen, 21.09.2015

This work is dedicated to my family

# Acknowledgment

This Diploma Thesis was carried out within the Erasmus framework at RWTH Aachen University, laboratory of process systems engineering under the supervision of Professor Alexander Mitsos to whom I would to express my deep and sincere gratitude. I would also like to thank very much the researcher and PhD student, Kirsten Ulonska for the continuous monitoring and support of this work. Last but not least my deep and sincere appreciation should be also expressed to Professor Antonios Kokossis who gave me the opportunity to participate in this Erasmus program.

# Abstract

Biofuels serve as a renewable alternative to fossil fuels and a lot of research is carried out about them in the EU with the ambition of reducing the carbon dioxide's emissions and improve the EU's security of supply. The aim of this work is to add a complementary criterion in Reaction Network Flux Analysis(RNFA) regarding the separations processes which until now were considered ideal. The methodology should be able to be implemented to every reaction network with the precondition that the properties of the compounds are known. The backbone of this work is a code written in Matlab®concerning firstly the choice of the separation process for the binary system examined and then the estimation of the cost and the energy demand. The ranking of the fuel candidates tends to change when implementing lower separation efficiencies and this indicates the necessity of this complementary criterion concerning the separation processes. As a result this complementary criterion may be crucial for the evaluation of the fuel candidates pathways. The results of the evaluation are presented and then a sensitivity and a monte carlo analysis are executed to appraise the reliability of the methodology. The analysis shows that the results can be reliable at an early stage design of a biorefinery, despite some uncertainties that may appear in some calculations. The methodology leads to some safe conclusions as well as some possible improvements that could be made.

# Contents

List of Figures	vii
List of Tables	ix
<b>1. Introduction</b>	<b>1</b>
<b>2. State of the art</b>	<b>3</b>
2.1. Tailor-Made Fuels from Biomass . . . . .	3
2.2. Reaction Network Flux Analysis . . . . .	4
2.2.1. Reaction Networks . . . . .	4
2.2.2. Evaluation criteria . . . . .	5
2.2.2.1. Mass-related criteria . . . . .	5
2.2.2.2. Energy-related criteria . . . . .	6
2.2.2.3. Cost-related criteria . . . . .	7
2.2.2.4. Environmental-related criteria . . . . .	7
2.3. Other approaches and tools . . . . .	8
<b>3. Methodology</b>	<b>10</b>
3.1. Scope and state of the art . . . . .	10
3.2. Separation Processes . . . . .	11
3.2.1. Drawbacks . . . . .	13
3.3. Split factors choice and calculations . . . . .	15
3.3.1. Distillation . . . . .	17
3.3.2. Flash . . . . .	18
3.3.3. Azeotropic Distillation . . . . .	19
3.3.4. Crystallization . . . . .	21
3.3.5. Liquid Liquid Extraction . . . . .	22
3.3.6. Gas phase . . . . .	24

*Contents*

---

<b>4. Results and case study</b>	<b>25</b>
4.1. RNFA results . . . . .	27
4.2. Influence of the separation efficiency on biofuels ranking . . . . .	29
4.3. Cost and energy calculations of separation processes . . . . .	32
4.4. Sensitivity analysis . . . . .	35
4.4.1. Prices of utilities . . . . .	36
4.4.2. Rule of thumb constants . . . . .	37
4.4.3. Solvent price and solvent losses . . . . .	40
4.4.4. Separation efficiencies . . . . .	41
4.4.5. Energy demand deviation for the most promising fuel . . . . .	42
4.4.6. Boundaries of split factors . . . . .	43
4.5. Monte carlo analysis . . . . .	43
<b>5. Conclusions and future steps</b>	<b>46</b>
<b>Appendices</b>	<b>48</b>
<b>A. Appendix</b>	<b>49</b>
<b>Bibliography</b>	<b>57</b>

## List of Figures

2.1. Tailor-Made Fuels from Biomass[22] . . . . .	3
3.1. State of the art(I) and the goal(II), adopted from K. Ulonska,2015, personal communications	
3.2. Citric Acid concentration in water at various temperatures[8],[9] . . . . .	14
3.3. Itaconic Acid concentration in water at various temperatures[15],[24], [9] . . . . .	14
3.4. Succinic Acid concentration in water at various temperatures[18],[8] . . . . .	14
3.5. Glutamic Acid concentration in water at various temperatures[9] . . . . .	15
3.6. Pressure swing distillation[23] . . . . .	20
4.1. The reaction network from Ulonska et al. (2015) . . . . .	26
4.2. Fuel candidates . . . . .	28
4.3. Influence of the separation efficiencies on TAC for three promising fuel candidates	29
4.4. Influence of the separation efficiencies on Environmental Impact for three promising fuel candidates	
4.5. Influence of the separation efficiencies on Hydrogen requirement . . . . .	31
4.6. Influence of the separation efficiencies on the yield(MJ/MJ fuel) . . . . .	32
4.7. Ranking of the fuel candidates regarding the separation processes . . . . .	35
4.8. How steam price affects some fuel candidates . . . . .	36
4.9. How electricity price affects some fuel candidates . . . . .	37
4.10. Influence at the results of the constant concerning distillation steam requirements	38
4.11. Influence at the results of the constant concerning flash steam requirements . . . . .	39
4.12. Influence at the results of the constant concerning electricity requirement . . . . .	39
4.13. Solvent losses influence on the total cost of some fuel candidates . . . . .	40
4.14. Separation efficiency influence on the cost and the energy demand . . . . .	41
4.15. Energy demand deviation for the most promising fuel candidates . . . . .	42
4.16. Monte Carlo analysis results for promising fuel candidates . . . . .	44
4.17. Monte Carlo analysis results for 2-MF(I) and 2-MF(V) in comparison to 2,5DMF(II)	45
A.1. Ethanol and butanol pathways . . . . .	49
A.2. 3-MTHF pathway . . . . .	49

*List of Figures*

---

A.3. Ethyllevulinate pathway . . . . .	50
A.4. 2-MTHF(I) pathway . . . . .	50
A.5. 2-MTHF(II) pathway . . . . .	51
A.6. 2-MTHF(III) pathway . . . . .	51
A.7. 2-MTHF(IV) pathway . . . . .	52
A.8. 2-MTHF(V) pathway . . . . .	52
A.9. 2-MF(I) pathway . . . . .	53
A.10.2-MF(II) pathway . . . . .	53
A.11.2-MF(III) pathway . . . . .	53
A.12.2-MF(IV) pathway . . . . .	54
A.13.2-MF(V) pathway . . . . .	54
A.14. THF pathway . . . . .	55
A.15.2.5DMF(I) pathway . . . . .	55
A.16.2.5DMF(II) pathway . . . . .	56
A.17.2.5DMTHF(I) pathway . . . . .	56
A.18.2.5DMTHF(II) pathway . . . . .	56



# List of Tables

2.1. Mass-related evaluation criteria[26]	6
2.2. Energy-related evaluation criteria[26]	6
2.3. Cost-related evaluation criteria[26]	7
2.4. Environment-related evaluation criteria[26]	8
3.1. Common separation processes and the corresponding properties according to Jakslund et al.	
3.2. Heat of fusion follows a different pattern from the gradient and the solubility at 0°C	15
3.3. Utilities and their prices	16
4.1. Fuel candidates and their corresponding number of pathways	25
4.2. Basic evaluation criteria	27
4.3. Additional evaluation criteria	27
4.4. Hydrogen requirements	27
4.5. Parameters values[25] , [2]	33
4.6. Promising fuel candidates	33
4.7. Fuel candidates that can be excluded	34
4.8. More fuel candidates	34
4.9. Parameters values for the sensitivity analysis	36
4.10. Parameter with the most significant influence for the most promising fuel candidates	43

# 1. Introduction

The last decades fossil fuels tend to be not enough to cover increasing human's needs taking also into account the augmented energy needs. So scientists all over the world are trying to figure out new ways to cover this energy demand. Under these circumstances renewable raw materials are attaining particular interest in the production of chemicals and fuels. However the energy demands is not the only reason that forces scientists to invent new ways to cover our energy needs. The environmental problem caused mainly by the increased CO<sub>2</sub> emissions should not be ignored. To make a long story short, some years ago the idea of creating fuels from biomass came under extensive investigation and that is how first generation bio-fuels were created.

Although the idea was innovative, first generation biofuels are competing with food production. That is a problem needed to be solved. Second Generation bio-fuels have been developed to overcome the limitations of first generation bio-fuels. They are produced from non-food crops such as wood, organic waste, food crop waste and specific biomass crops, therefore eliminating the main problem with first generation bio-fuels. Nowadays plenty of different bio-fuels are produced or there are plans and proposals to be produced mainly from lignin, cellulose and hemicellulose. Until today ethanol is the most used one but a lot of research is done in order to find other competitive bio-fuels. Second generation plants are expected to decrease oil dependency from high risk countries, stimulate economic growth and address climate change through emissions reduction. All over the world but mainly in US, Europe and China large investments are available to bring lab-scale developments into commercial scale, according to a recent study (EuropaBio,2011)[10].

Research now is also focused on finding bio-fuels that are competitive to ethanol. Moreover several possible candidates can be considered as promising bio-fuels. In few words there are huge networks with many candidates that need to be evaluated. A screening tool is trustworthy for a first and fast evaluation aiming mainly to exclude the fuel candidates that have no chances to compete ethanol.

## *1. Introduction*

---

At RWTH Aachen university many scientists are trying to find sustainable tailor-made bio-fuels for clean combustion. This idea has become reality for example with RNFA (Reaction Network Flux Analysis) methodology or Superstructural approach. The pathways are evaluated mainly in economical and ecological perspective. However the RNFA methodology until now was built on ideal separations. This work is based on RNFA methodology while trying to implement complementary criteria concerning the separation processes. This model based screening method (RNFA) tries to generate a systematic assessment of reaction pathways in the early stage of process design.

Within this work the RNFA methodology is extended on this matter, taking into consideration the efficiency of separation processes, choosing the appropriate one and calculating the costs and the energy demand of the separation processes.

In the following chapter the Tailor Made Fuels from Biomass (TMFB) concept as well as the RNFA methodology are explained. Afterwards the methodology and the theory of this work are introduced and the reaction network is presented. Furthermore the algorithm is explained and the new criteria are presented as well as the uncertainties of the algorithm and how they affect the results. Then the first results are shown so the influence of separation processes becomes obvious. A sensitivity analysis is executed to test the reliability of the results and at the last chapter future challenges are presented.

## 2. State of the art

This work is a project which is included in the initiative of the RWTH Aachen University to develop Tailor-Made fuels from biomass. Moreover Reaction Network Flux Analysis is the idea that this work is based on. Both are described at this chapter as they are necessary in order to comprehend the methodology and the results that follow.

### 2.1. Tailor-Made Fuels from Biomass

The Tailor-Made Fuels from Biomass(TMFB) is a cutting-edge research initiative originated in 2007 from a cluster of excellence at RWTH Aachen University. According to the originators their vision is to "establish innovative and sustainable processes for the conversion of whole plants into fuels which are tailor-made for novel low-temperature combustion engine processes with high efficiency and low pollutant emissions, paving the way for 3rd generation bio-fuels".[22] Tailor-Made Fuels from Biomass are considered "well-defined blends of distinct molecular components with optimized physicochemical properties for future combustion systems, which can be produced by sustainable and economical production properties".[22] The production route of bio-fuels from biomass is presented in figure 2.1 together with a desired goal of the above mentioned TMFB research initiative[22].

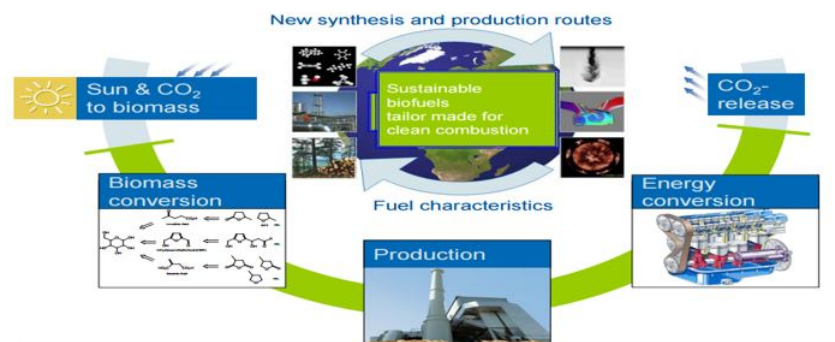

Figure 2.1.: Tailor-Made Fuels from Biomass[22]

The advantage of TMFB is derived not only from the molecular structure of the product but from its optimized production process as well.[14] All research activities carried out within TMFB initiative are aiming towards the production of an optimized tailor-made fuel. Primarily, this requires that the bio-fuels should exhibit specific properties under particular conditions. An ideal, tailor-made fuel from biomass should be sustainable, clean while its production and combustion is energetically optimized[1].

## 2.2. Reaction Network Flux Analysis

The production of bio-fuels with the properties previously mentioned requires the identification of the pathways that could be superior to existing bio-fuels, such as ethanol, and the corresponding production processes. To achieve this goal an evaluation tool called Reaction Network Flux Analysis (RNFA) has been proposed [26], [1]. A production pathway practically is considered as series of consecutive steps through which the starting materials are transformed to the final target compound. RNFA methodology is used for the assessment of these pathways in regard to specific criteria which are presented in the following sections.

### 2.2.1. Reaction Networks

For given raw materials and final product, there are a lot of reaction pathways possible that can produce the same result. A network of the considered reaction network is set up first as a basis. Initially the pathways of the reaction network should be identified. Then extensive literature research must be carried out in order to collect all the data needed concerning the reactions. Afterwards the properties of the compounds should be found. In some occasions however it might be difficult to retrieve all the required data from the literature. The next step is the construction of the reaction network. In order to overcome this difficult task some tools, like the Rule Input Network Generator (RING)[5], could be employed. The structure of the reaction network including the stoichiometric equations of the reactions is vital for RNFA. Many experimental data are available already in several databases, but there are some cases where prediction of some properties is needed in order to obtain acceptable estimations taking into consideration the uncertainties of the methodology.

The network design can be exhibited as a graph consisting of nodes resembling the substances and arcs resembling the reactions. The arcs show the direction of the reaction while they can

connect more than two nodes, if a reaction has multiple reactants or products[1]. As a result, the stationary material balances of the network can be formulated as follows

$$A * f = 0 \quad (2.1)$$

where A is the matrix of the stoichiometric coefficients and f the vector of the molar fluxes.

In addition the molar balance should be introduced :

$$A * f = b \quad (2.2)$$

where b vector covers all molar product flows.[26]

### 2.2.2. Evaluation criteria

The evaluation criteria consist the backbone of the RNFA methodology. After the network construction and the creation of the appropriate databases a code is needed to be able to extract results that should be reviewed in a way permitting to exclude some of the pathways and identify the most promising of them.

The criteria used can be classified into four categories related to[1]:

1. Mass
2. Energy
3. Cost
4. Environment

#### 2.2.2.1. Mass-related criteria

Reaction routes vary in both main and auxiliary reactants as well as in by-products formation. To calculate these amounts, mass balances of the reactions are used. In every case it should be taken into consideration either how much raw material is required for a certain amount of production or how much product is produced from a certain amount of raw material. Regardless of the choice of this approach material supply  $f_{1,i}$ (biomass, hydrogen, water) and the product formation  $b_i$  must be considered for all relevant substances. When biomass is converted, the

## 2. State of the art

---

flows of hydrogen  $f_{H_2}$  by-products water,  $b_{H_2O}$  and carbon dioxide,  $b_{CO_2}$ , should be taken into account.[26] Table 2.1 shows the evaluation criteria.

Evaluation criteria	Definition
raw materials	$f_{1,i}$
main reactant	$f_{1,react}$
hydrogen	$f_{1,h_2}$
main product	$b_{tar}$
water	$b_{h_2O}$
carbon dioxide	$b_{CO_2}$
product yield	$Y_{tar} = \frac{b_{tar}}{f_{1,react}}$
number of reaction steps	$N_R$
carbon efficiency	$n_C = \frac{b_{tar} N_{C,tar}}{\sum_{i=1}^s f_{1,i} N_{C,i}}$

Table 2.1.: Mass-related evaluation criteria[26]

### 2.2.2.2. Energy-related criteria

Except from mass-related criteria, a number of additional criteria is introduced for the evaluation of the energy balance of every reaction pathway. On the table below two energy related criteria are demonstrated as well as the equation for their calculation. Both of them calculate the energy efficiency. The first one is based on the enthalpy of combustion  $H_{com,i}$  and the second one on the enthalpy of formation  $H_{form,i}$  always at standard conditions (1 atm, 25 °C). [26]

Evaluation criteria	Definition
combustion	$n_{E,com} = \frac{b_{tar} H_{com,tar}}{\sum_{i=1}^s f_{1,i} H_{form,i}}$
formation	$n_{E,form} = \frac{b_{tar} H_{form,tar}}{\sum_{i=1}^s f_{1,i} H_{form,i}}$

Table 2.2.: Energy-related evaluation criteria[26]

### 2.2.2.3. Cost-related criteria

Lange (2001)[16] also pursues the idea of deriving more criteria from a simple energy balance. Based on Lange , A. Voll and W. Marquardt[1] connects the Investment Cost(IC) with the loss of energy ( $\Delta E$ ) of a production system determining the parameters Invest1 and Invest2 to  $3 * 10^6$  and 0.84 based on historical data. Then at the table 2.3 the calculation of the Total Annualized Cost (TAC) is illustrated, based on IC using the interest rate  $z$ , the integer plant lifetime  $t_{run}$ , the raw material cost  $p_i$  and the material flows  $f_{1,i}$  (Biegler et al., 1997)[4]. The equations are demonstrated in table 2.3.[26]

The energy loss  $\Delta E$  can be determined from [26]

$$\Delta E = \sum_{i=1}^n f_{1,i} |H_{com,i}| - b_{tar} |H_{com,tar}| \quad (2.3)$$

Evaluation criteria	Definition
investment cost	$IC = Invest1 * \Delta E^{Invest2}$
total annualized cost	$TAC = \frac{IC * z}{1 - (1 + z)^{t_{run}}} + \sum_{i=1}^s f_{1,i} p_i$
raw material cost	$p_{max, reac} = \frac{b_{tar} p_{tar} - \frac{IC * z}{1 - (1 + z)^n}}{f_{1, reac}}$

Table 2.3.: Cost-related evaluation criteria[26]

### 2.2.2.4. Environmental-related criteria

The environmental impact criterion which is taken into consideration for RNFA methodology is based on the eco-efficiency analysis (EEA) of Saling et al. (2002). The RNFA takes into consideration only four of the total six indicators of the EEA because the other two(land use and risk potential) must be used in a later design stage due to lack of input data at this stage. [26]

The indicators that are used are the following

1. Energy consumption
2. Resource consumption



3. Emissions
4. Toxicity

In the table 2.4 it is demonstrated how the four indicators are calculated, normalized by the maximum value they reach in any pathway and then summed up to come up with the environmental impact(EI).[26]

Evaluation criteria	Definition
energy consumption	$EC = \frac{\Delta E}{M_{tar}b_{tar}}$
resource consumption	$RC = \frac{\sum_{i=1}^s f_{1,i}b_{tar}}{M_{tar}b_{tar}}$
emission impact	$Em = \frac{M_{CO}b_{CO} + M_{CO_2}b_{CO_2} + 25M_{CH_4}b_{CH_4}}{M_{tar}b_{tar}}$
toxicity	$TP = M_{tar}b_{tar}TS_{tar}$
environmental impact	$EI = \frac{EC}{ EC _{\infty}} + \frac{RC}{ RC _{\infty}} + \frac{Em}{ Em _{\infty}} + \frac{TP}{ TP _{\infty}}$

Table 2.4.: Environment-related evaluation criteria[26]

Here it is also introduced the normalized environmental impact[26]:

$$EI' = \frac{EI}{|EI|_{\infty}} \quad (2.4)$$

## 2.3. Other approaches and tools

Several different approaches for pathway evaluation can be found in the literature. Among which superstructure optimization has received much attention. Moreover some additional tools, like RING, are also available for generating reactions networks.[5]

According to Daoutidis et al.(2013) RING tool is used to generate all possible reactions and products using as inputs the reactants and the corresponding reaction rules. Therefore this particular computational tool could work complementary to the RNFA methodology because with RING all possible pathways are revealed which at the next step are evaluated by RNFA.[5]

Superstructure optimization is an alternative systematic method used among others for the evaluation of chemical process networks. It is a strategy for the optimization of a process system in regard to fulfillment of the production demands while taking into consideration a series of constraints like raw material availability, environmental concerns etc[11]. In other words it practically addresses the process synthesis problem to identify the optimal process structure and operational conditions. Usually all the objective functions create a global optimization problem which is transformed to a Mixed Integer Non linear Programming problem and a computer aided solution is obtained. However according to Henao and Maravelias [11] this kind of problems can't be always solved effectively. In most cases the objective function that is tried to be optimized is cost.

The basic difference of the superstructure optimization from RNFA methodology is that in the former both the network and the chemical processes are examined in detail using software like Aspen Plus while in the latter the necessary details for a safe conclusion are much less.

The steps of superstructure optimization are the following[21]

1. Problem definition
2. Development of superstructure : All potential alternatives in the processing network are represented by a particular schematic form, which is called the superstructure (Grossmann, 1990)
3. Modeling : The proposed optimization model includes
  - Mass balance constraints
  - Objective function
4. Computational issues
  - Linearization of mixed integer products
  - Solution of the optimization formulation
  - Comparison and discussion of the results

## 3. Methodology

At this chapter the methodology as well as the network examined at this work are presented. The purpose is to create a general applicable methodology however all the tests are executed at the network which is presented in the following sections.

### 3.1. Scope and state of the art

Until now the RNFA methodology was generating results assuming ideal separations. So the results were from one side reliable however from the other side it was clear that the pathways differ in terms of the number of separation processes and their cost.

This work intends to implement also the separation processes as additional variables and determine their influence on the evaluation criteria. The first step was the implementation of different separation efficiencies where a change of solvent is needed in order to check according to the evaluation criteria, which are already discussed, how much it affects its pathway.

Then a code in Matlab is written which can automatically suggest, according to simple criteria, separation processes and calculate an approximate cost of the process. For this purpose more extended databases are needed for the compounds of the network. As a result new criteria are considered enabling the calculation of the cost and the energy needed for each separation process.

Figure 3.1 represents the state of the art and the goal of this work. The blue nodes refer to the compounds at a pathway and the red squares refer to the separation processes that this work implements.

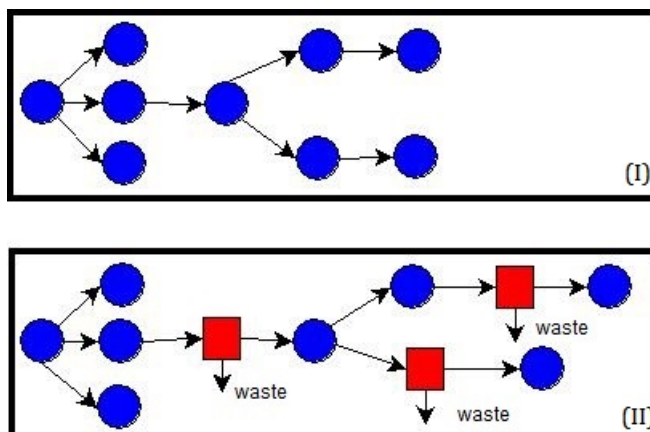

Figure 3.1.: State of the art(I) and the goal(II), adopted from K. Ulonska,2015, personal communications

The purpose of this work was to develop a generally applicable methodology to address every network of reactions provided that the databases with the necessary properties of the compounds are available. To achieve this some assumptions are needed so the code could be proved fast and effective. The assumptions adopted for this work are as follows.

1. Only binary separations are considered.
2. A five percent loss of solvent is taken into consideration for the extraction.
3. Separation were considered only during the solvent change and in cases that it is necessary to increase the concentration.
4. The rule of thumb proposed by Hermann (2006) [12] is employed for calculating the energy needed for distillation.
5. The properties of the compounds that were not found in the literature were estimated through CAMD/Aspen.

## 3.2. Separation Processes

In a conventional refinery several separation processes are needed to finally produce a fuel. In a biorefinery the procedure from this respect does not differ substantially as several separation

### 3. Methodology

---

processes are employed in every potential pathway in order for the biofuel to be produced. Keeping this in mind, the idea was a complementary evaluation criterion to be implemented regarding the separation processes. At this point it should be mentioned that at this work it is considered that separation processes are needed only in cases of changing solvents and in few cases in which a concentration increase is mandatory. Moreover, all the separations are considered as binary separations.

The influence of the separation efficiency for each pathway is presented. Moreover it is examined whether this change affects the ranking order of the biofuels presented at tables 4.2 and 4.3. Then the ability of the code for the estimation of the cost of each separation process is demonstrated.

The idea of implementing a complementary evaluation criterion concerning the separation processes needs to be materialized. The only step that was required in every approach, was the one where the separation processes had to be chosen. Moreover a way has to be found in order for this identification to be carried out in a fast and effective way without using simulations for every separation.

The methodology of Jaksland et al.[13] includes a systematic analysis of a wide range of physical and chemical properties of the components of the mixture to be separated. Then it identifies the suitable separation techniques, based on differences in these properties among the components to be separated.

In other words Jaksland attempts to connect every separation process with physicochemical properties that can be found in databases or can be calculated through models. So for binary systems the proposal was to set some limits for these properties and then these limits will determine if a separation process is feasible or not.

In our case as already mentioned all the mixtures are binaries so according to Jaksland et al. a corresponding ratio,  $r_{i,j}$  could be calculated from :

$$r_{i,j} = \frac{P_{AJ}}{P_{BJ}} \quad (3.1)$$

Table 3.1 depicts these separation processes and their corresponding properties.

Jakscland et al.(1995) [13] have proposed a complete algorithm that is supposed to work effectively for all the binary mixtures. However before implementing the proposed algorithm

Separation Process	Important pure component property
Azeotropic Distillation	Formation of azeotrope
Crystallization	Heat of fusion
Distillation	Vapor pressure and boiling points
Flash	Vapor pressure and boiling points
Liquid Liquid extraction	Solubility parameter

Table 3.1.: Common separation processes and the corresponding properties according to Jaksland et al. (1995) [13]

an evaluation was necessary. This was applied in our network for binaries mixtures. However some drawbacks were noticed.

#### 3.2.1. Drawbacks

For the majority of the cases of the binary mixtures examined in our work the algorithm proposed by Jaksland was working efficiently. However in some particular cases in our network the results included many uncertainties that could be vital for the evaluation. Moreover in the paper published on this subject from Jaksland et al. (1995) [13] some of the necessary limits to make the algorithm work were not available.

At the table 3.2 it can be noticed one problem concerning the Crystallization. Two important criteria when we have experimental data are the solubility at a low temperature( i.e. 5°C or 0°C) and the gradient which shows how the solubility is decreasing when the temperature is decreased,as presented at the figures 3.2 ,3.4, 3.3 and 3.5. The criterion proposed by Jaksland should follow the same pattern as these two characteristics. However as shown at table 3.2 the heat of fusion in the example demonstrated has a different pattern from these two criteria. As a result heat of fusion is not always adequate to determine the feasibility of crystallization.

### 3. Methodology

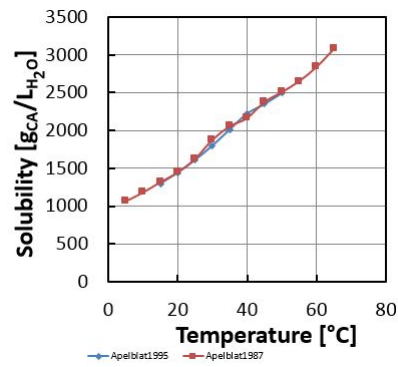

Figure 3.2.: Citric Acid concentration in water at various temperatures[8],[9]

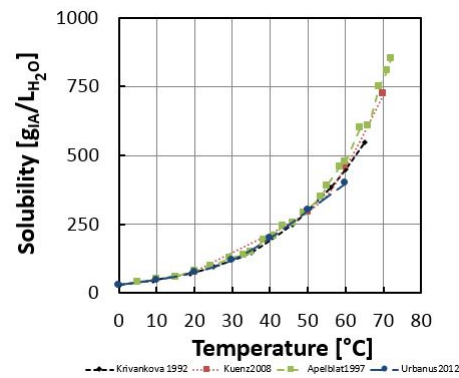

Figure 3.3.: Itaconic Acid concentration in water at various temperatures[15],[24], [9]

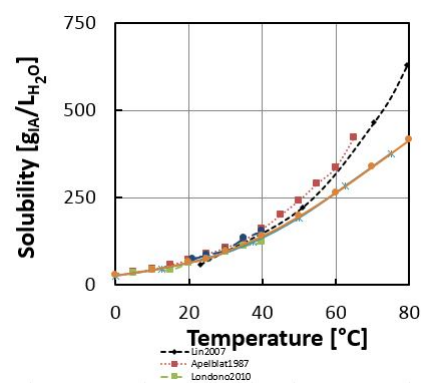

Figure 3.4.: Succinic Acid concentration in water at various temperatures[18],[8]

### 3. Methodology

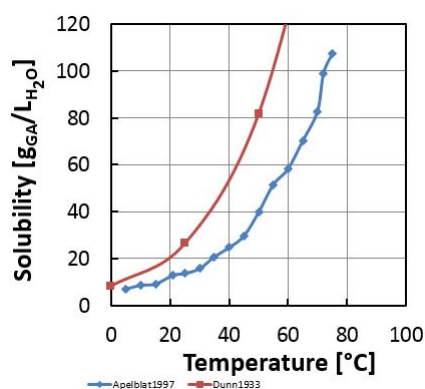

Figure 3.5.: Glutamic Acid concentration in water at various temperatures[9]

	Itaconic Acid	Succinic Acid	Glutamic Acid	Citric acid
Heat of fusion ( $j/mol$ )	24440	32945	38080	36680
Gradient	7.95	3.54	0.5	30
Solubility at 0°C ( $g/L$ )	30	40	7	1100

Table 3.2.: Heat of fusion follows a different pattern from the gradient and the solubility at 0°C

From table 3.2 it can be noticed that crystallization is not feasible for citric acid aquatic solution however its values for heat of fusion is between the values of the other three compounds that can be separated efficiently from water with crystallization.

Another problem with Jaksland's algorithm and methodology is the fact that some separation processes are connected with properties like the refractive index or the dipole moment (azeotropic distillation) which are difficult to be found from reliable sources for all the possible compounds of every network. However even if these properties are found, at the published paper there are no specific limits that determine the feasibility of a process.

### 3.3. Split factors choice and calculations

For the reasons mentioned at the previous chapter an extensive research was carried out to find the best split factors for the five following separation processes.

1. Azeotropic Distillation



### 3. Methodology

---

2. Crystallization
3. Distillation
4. Flash
5. Liquid-Liquid extraction

Before analyzing the split factors of every single separation process the rationale behind this idea should be clarified. The aim of this work is to create a code that will be able, using appropriate databases, to select the appropriate separation process and calculate the energy needed and finally the cost. The choice of the split factors is critical for the construction of the code and the concept is based on Jaksland's work. These five separation processes are connected to physicochemical properties and according to them the type of the separation process is determined. However, in most of the cases in order to decrease the uncertainties more split factors are added and some other are modified or completely changed. When the separation process is chosen then a simple and sufficient way should be applied to calculate the energy needed for each process and then its cost. So the next step for the construction of the code is the calculation of the energy demand based on the quantities and the basic properties of the compounds that need to be separated. There is no doubt there are uncertainties at the calculations as there is an attempt to be fast and efficient for every network. Most of the estimations are based on models found in literature with assumptions which will be mentioned in every different separation process[3].

The next step is the calculation of the cost of the separation processes. After the estimation of the energy demand the cost of the utilities is employed for this purpose. The table 3.3 presents all the utilities used for the separation processes as well as their prices.

Utilities	Price (\$)	Abbreviations
Electricity	70	el
Steam	36	st
Refrigeration	42	refr
Cooling water	61	cw

Table 3.3.: Utilities and their prices

### 3.3.1. Distillation

Distillation is probably the most common separation process for which many data for binary mixtures can be found. Therefore it was the one selected for the thorough investigation of the split factor choice. The connection of the distillation feasibility with the vapor pressure and the boiling points seems rational. However a simple and efficient way should be found. The goal is to avoid using phase diagrams with a lot of data for every single binary mixture.

Within the code the following steps are followed for checking the feasibility of the distillation:

1. Relative volatility check considering all the mixtures as ideal.
2. Check melting and boiling points to avoid solids in the mixtures

So the main criterion is well described by the following mathematical expression[13]:

$$1.5 < r_{i,j} = \frac{Vp_i}{Vp_j} < 10 \quad (3.2)$$

The mathematical expression 3.2 shows that the fraction of the vapor pressures of the compounds of the binary system should be between 1,5 and 10 in order for the distillation to be feasible. There is no doubt that the criterion used has uncertainties. However it worked adequately for many binary systems. Therefore it could be considered a good approximation which can be used efficiently at an early stage design.

The upper limit is set because after a specific value, flash could be feasible which is a cheaper choice.

An efficient and fast way to calculate the energy needed for the process is also crucial. A rational approach could be the use of McCabe-Thiele method[20] , [17]. However this method makes the algorithm complicated and the data needed in order to have reliable results are difficult to be found for every single compound of the network. It should be also kept in mind that the goal of this work is an algorithm which should be simple and efficient for every given network.

The rule of thumb proposed by Hermann (2006)[12] could be adopted as it fits the scope of the algorithm developed in this work. The application of the rule of thumb for a compound that is about to be evaporated requires :

1. The amount of the compound

#### 2. The heat of vaporization

So the equation to calculate the energy needed is the following:

$$Energy(kJ) = 1,3 * HoV * Q \quad (3.3)$$

where  $Q$  refers to the quantity of the most volatile compound and  $HoV$  to the heat of vaporization.

At this point also the cost needs to be estimated. It is assumed that all the energy needed is provided by steam. Consequently the cost is calculated as follows:

$$Cost(\$) = E(MWh) * Pr_{st} \quad (3.4)$$

Where  $E$  refers to the energy and  $Pr_{st}$  to the price of the steam

#### 3.3.2. Flash

The procedure for flash separation process is similar to distillation. The only difference here relates to the limits of  $r_{i,j}$  as we can see below[13]:

$$10 < r_{i,j} = \frac{Vp_i}{Vp_j} \quad (3.5)$$

For flash separation the criterion chosen has uncertainties as well but it worked efficiently for many binary systems with known properties.

In some of the binary mixtures examined at the network of this work flash separation process is feasible. The compounds of this binary mixture display a big difference on their vapor pressure. The energy of this process is calculated based again on Hermann's approach for the multistage vaporization of water[12]. This approach indicates that both steam and electricity are necessary. However different factors are used in each case. The equations 3.6 and 3.7 demonstrate Hermann's approach.

$$Energy_{st}(kJ) = 0,5 * HoV * Q \quad (3.6)$$

$$Energy_{el}(kWh) = 0,05 * Q \quad (3.7)$$

$$Energy_{el}(kJ) = Energy_{el}(kWh) * 3,6 * 10^3 \quad (3.8)$$

At the equation 3.9 the total energy requirement is calculated and also the units of the Energy for electricity are changed to kJ. In addition the factors of primary energy demand (PED) are used[7]. So in order to calculate the primary energy demand the following equation is used:

$$PED(kJ) = (E_{st} * 1.5031) + (E_{el} * 2.57) \quad (3.9)$$

The next step is the calculation of the cost. For each type of energy, as mentioned before, a different price is employed as follows:

$$Cost_{st}(\$) = E_{st}(MWh) * Pr_{st} \quad (3.10)$$

$$Cost_{el}(\$) = E_{el}(MWh) * Pr_{el} \quad (3.11)$$

$$Cost_{total}(\$) = Cost_{st} + Cost_{el} \quad (3.12)$$

#### 3.3.3. Azeotropic Distillation

For azeotropic distillation the idea of split factors could not be applied, as it is very difficult to connect a simple physicochemical property with the creation of an azeotrope. For the most used solvents in the network developed in this work a database was created with the solutes with which azeotropes are created. In this way the only thing needed is a correct and sufficient database to be read for all the binary mixtures of the network.

The network of this work also includes binary mixtures that form an azeotrope. The separation of these mixtures can be accomplished with either azeotropic distillation or Liquid-Liquid extraction. As far as azeotropic distillation is concerned there are four types

### 3. Methodology

1. Pressure swing distillation
2. Homogeneous azeotropic distillation
3. Heterogeneous azeotropic distillation
4. Extractive distillation

All types except from pressure swing distillation need an entrainer. The idea that the code should be able to be applied to every network indicates that for this stage the identification of the appropriate entrainer should be avoided. Therefore it is assumed that all the azeotropic distillations are based on the different compositions of the azeotrope at different pressures.

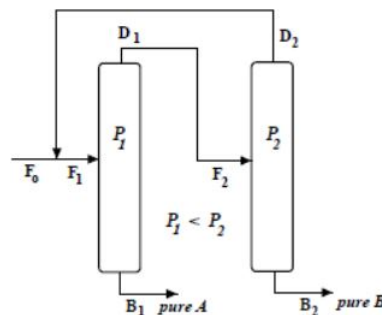

Figure 3.6.: Pressure swing distillation[23]

At this point the way that the energy demand is calculated should be demonstrated[23]. Figure 3.6 presents the model on which the calculations are based. In all our cases the boiling point of the azeotrope is lower than the boiling point of both compounds of the binary system, so at the first column the azeotrope is evaporated. At the second column it is assumed that the azeotrope which is formed includes the whole amount of the compound that has a lower boiling point and a very small amount of the other compound, which is not taken into consideration. This is the way that the quantities which are evaporated are calculated. In the network examined azeotropes like water-ethanol and water-butanol are faced.

The equation 3.13 presents what was described at the previous paragraph:

$$Energy(kJ) = (1,3 * HoV_{comp2} * Q_2) + (1,3 * HoV_{comp1} * Azcomp * Q_2 * 2) \quad (3.13)$$

where HoV refers to heat of vaporization, Q to the amount of the compounds and Azcomp to the composition of the azeotrope that is formed at 1 atm. The second part of the equation 3.13 is multiplied by 2 as a specific amount of the most volatile compound is evaporated twice.

The concept followed for distillation and flash separation processes is also applied for azeotropic distillation. Hence the equation 3.14 presents the calculation of the cost.

$$Cost(\$) = E(MWh) * Pr_{st} \quad (3.14)$$

#### 3.3.4. Crystallization

The approach used for this process is similar to Azeotropic distillation. Also for crystallization the choice is based on using databases for mixtures with water as solvent. As it was mentioned at the previous chapter Jakslund's approach on this topic is has many uncertainties and in some cases it is not efficient. So the split factors are based again on experimental data.

As there are enough experimental data the two final split factors chosen are as follows :

1. Solubility at 0°C
2. And the gradient of the graph temperature vs concentration

The solubility at 0°C could be a good indicator of how much solute can be obtained. Furthermore is not so expensive to reach 0°C. It should be mentioned that the gradient plays also an important role on the decision for the feasibility of crystallization. The criteria selected for the feasibility are presented below:

1. solubility at 0°C < 36g/L
2. gradient of temperature vs concentration > 40
3. solubility at 0°C < 100g/L and gradient of temperature vs concentration > 15

These values were chosen after some tests with binaries systems for which the feasibility of crystallization is known. There are some uncertainties but they can be accepted in an early stage design.

### 3. Methodology

---

As it was mentioned at the previous chapter experimental data are used to investigate the feasibility of crystallization. One of the two criteria which were used is the solubility of a compound at 0 °C. The mixture should reach 0°C. In the network there are reactions taking place in high temperatures. Therefore in some cases the temperature should be decreased more than 200°C.

The idea at this point was to reach 30°C with cooling water and then use refrigeration until 0°C. The energy needed for this process can be calculated from the following equation:

$$Energy(kJ) = Q_1 * C_{p1} * \Delta T + Q_2 * C_{p2} * \Delta T - HoF_{solute} * Q_{solute} \quad (3.15)$$

where Q refers to the amounts of the compounds,  $C_p$  to the heat capacity and  $\Delta T$  to the temperature difference. At equation 3.15 energy is gained by the transformation of the solute to a solid state. So HoF refers to heat of fusion which is multiplied with the amount that changes phase.

For crystallization cooling water can be used to reach 30°C and then refrigeration to reach 0°C. So the amount of energy calculated from equation 3.15 was divided in two parts:

1.  $T_{solution} \rightarrow 30^\circ C$  :

$$Energy_1 = E * \frac{T_{solution} - 30}{T_{solution}} \quad (3.16)$$

2.  $30^\circ C \rightarrow 0^\circ C$  :

$$Energy_2 = E * \frac{30}{T_{solution}} \quad (3.17)$$

So the cost is calculated as follows:

$$Cost(\$) = E_1 * Pr_{cw} + E_2 * Pr_{refr} \quad (3.18)$$

#### 3.3.5. Liquid Liquid Extraction

For this separation process the partition coefficient was chosen as the most reliable split factor. The following equation shows how the partition coefficient works:

$$P_{octanol/water} = \log\left(\frac{[solute]_{octanol}}{[solute]_{water}}\right) \quad (3.19)$$

### 3. Methodology

---

Based on equation 3.19 for a mixture with water as solvent and negative partition coefficient, octanol can be used to obtain the solute. This is also working in the opposite way where octanol is the solvent but the partition coefficient is positive water can be used to obtain the solute. In both cases an extra separation process is needed, probably distillation.

The criterion for the feasibility of liquid-liquid extraction is the partition coefficient of the solute as shown at the equation 3.19. As a result using this coefficient the tendency of a compound to create a mixture either with water or with octanol is determined. Consequently there are two cases:

1. A solute dissolved in water is more soluble in octanol
2. A solute dissolved in octanol is more soluble in water

At the first case octanol should be bought and at the second water. However in order to obtain the extractive agent a second separation process is needed. In this work distillation is always effective for these cases. Hence the energy demand is calculated with the rule of thumb as demonstrated at the corresponding chapter.

At this case the cost is related mainly with the amount of the solvent that is needed to be bought. For this work it is assumed that the loss of solvent is 5 percent and that the amount used is the same with the amount of the solvent at the first mixture. So the equation depicts the cost for the extraction.

$$Cost(\$) = Q_{solvent} * Pr_{solvent} \quad (3.20)$$

However as it was mentioned before there are two cases:

1. the solvent is water so the price is 0.27\$ per tonne [6]
2. the solvent is octanol so the price is 500.5\$ per tonne[2]

In this work distillation works in every case. Therefore both an additional cost and an energy demand should be calculated for the distillation as explained at the corresponding chapter.



### 3.3.6. Gas phase

The concept for the case that a mixture appears in gas phase is to bring it at a temperature where one of the two compounds is liquefied and separate them. The two split factors are shown at the following list:

1. Vapor pressure fraction :  $10 < r_{i,j} = \frac{Vp_i}{Vp_j}$
2. Difference of boiling points  $|Bp_a - Bp_b| \geq 10^\circ C$

In case of mixtures at gas phase, the relative volatility is determining the feasibility of the separation process. Then the difference of their boiling points is measured and if found bigger than  $10^\circ C$  the solution might be to liquefy the compound with the higher boiling point.

So the energy needed is directly connected with the energy to decrease the temperature to one or two degrees lower than the higher boiling point. The equation for the calculation is the following:

$$Energy(kJ) = Q_1 * C_{p1} * \Delta T + Q_2 * C_{p2} * \Delta T - HoV_{solute} * Q_{solute} \quad (3.21)$$

where at this case  $\Delta T$  refers to the different change from the temperature of the mixture to a degree lower than the higher boiling point. Now energy is obtained from the liquefaction of the compound so heat of vaporization is used.

Therefore the same concept is followed for the calculation of the cost at this case. The equation 3.22 demonstrates the calculation.

$$Cost(\$) = E(MWh) * Pr_{cw} \quad (3.22)$$

## 4. Results and case study

Firstly at this chapter the network examined is demonstrated. All the results generated, before and after implementing the separation efficiencies as an complementary criterion, are also presented. First results concerning ideal separation are exhibited and then follows the case study after the implementation of the separation efficiencies.

As described above the whole strategy of RNFA is based on a network of reactions that should be well analyzed, while the appropriate databases should be also taken into consideration.

In figure 4.1 the highlighted compounds are the fuel candidates and for some of them there is more than one way for their production. Therefore these alternative pathways should be considered together with their possible combinations.

At table 4.1 there is a list of all the fuel candidates and the number of pathways which are evaluated in this work. At the appendix all the pathways are presented.

Compound	Number of pathways
3-MTHF	1
2-MF	5
2-MTHF	5
Ethanol	1
Butanol	1
Ethyllevulinate	1
2,5 DMF	2
2,5 DMTHF	2

Table 4.1.: Fuel candidates and their corresponding number of pathways

#### 4. Results and case study

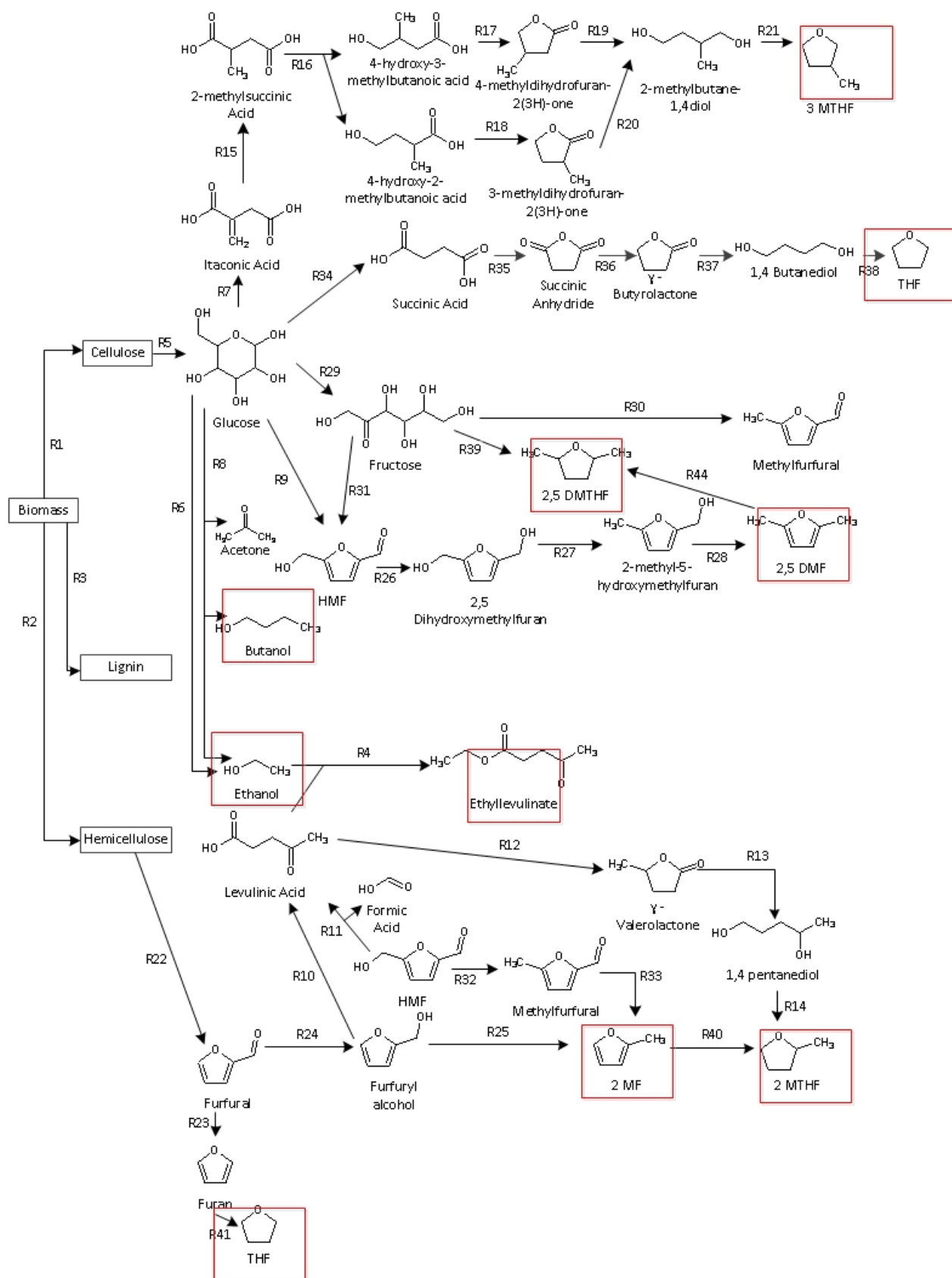

Figure 4.1.: The reaction network from Ulonska et al. (2015)

## 4.1. RNFA results

Based on the code which assumes ideal separations, a series of preliminary results were generated. Adopting TAC and environmental impact as the evaluation criteria the biofuels are ranked as presented at table 4.2. When considering other evaluation criteria like hydrogen requirements, the product yield and the energy yield the ranking is modified as shown in table 4.3.

TAC	Values	Environmental Impact	Values
Ethyllevulinate	39.4	Ethyllevulinate	0.8
Ethanol	+0.6%	2.5 DMTHF (I)	+12.4%
2-MTHF (V)	+44.9%	2-MTHF (V)	+13.1%
2.5 DMTHF (I)	+59.6%	Ethanol	+21.8%
2-MTHF(I)	+60.9%	2-MTHF(I)	+26.7%

Table 4.2.: Basic evaluation criteria

Yield (g product/g biomass)	Values	Yield (MJ fuel/MJ biomass)	Values
Ethyllevulinate	0.41	2-MTHF (V)	0.8
Ethanol	-12.2%	2.5 DMTHF (I)	-1.1%
2-MTHF (V)	-17.6%	Ethyllevulinate	-11.6%
2.5 DMTHF (I)	-21%	2-MTHF(I)	-12.1%
2-MTHF(I)	-27.3%	Ethanol	-14.1%

Table 4.3.: Additional evaluation criteria

From all tables 4.2 ,4.3 and 4.4 it can be concluded that some compounds such as ethyllevulinate could be initially considered possible alternatives to ethanol.

Hydrogen requirements	Values
Ethyllevulinate	0.25
Ethanol	0
Butanol (V)	0
2-MF (I)	0
2-MF(II)	0

Table 4.4.: Hydrogen requirements

#### 4. Results and case study

However this claim should be thoroughly investigated finalizing such a proposal. Moreover from the above list some compounds could be excluded for cost and environmental reasons. Some examples are 2-MF(II) and 2-MTHF(IV).

Another way to present the above data is to plot the fuel candidates using the TAC and the environmental impact as illustrated in figure 4.2. The bio-fuels that are closer to zero indicate their potential to be alternatives to ethanol as they exhibit minimal environmental impact relatively to the cluster of compounds shown in the upper part of the figure.

As a result RNFA methodology can adequately differentiate the bio-fuels based for example on TAC and environmental impact resulting in the exclusion of some candidates.

However other additional, process related, criteria could be considered to further improve the selection procedure. More in particular the separation efficiency is considered at this work. Then a new code was developed to find out which is the appropriate separation processes in each case. Finally the energy demand and the cost of the processes are estimated and considered as complementary separation criteria.

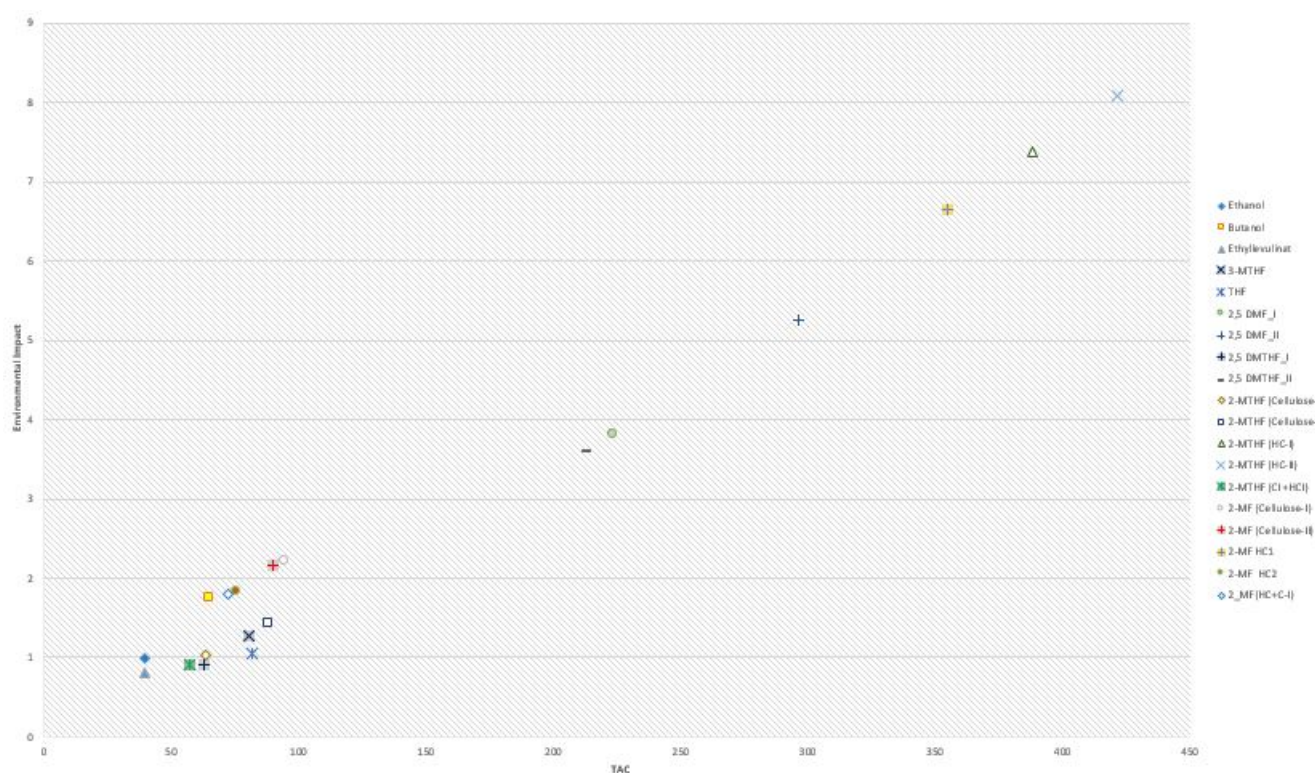

Figure 4.2.: Fuel candidates

A first conclusion can be that the most promising pathways according to RNFA methodology, without considering separation processes, are those which have less and more efficient chemical processes until their production. The heat of combustion of the fuel candidate plays also a significant role because it determines the quantity of the biomass needed.

### 4.2. Influence of the separation efficiency on biofuels ranking

At a first glance the results showed that after the inclusion of the separation efficiency as variable all the the criteria were affected resulting in the modification of the ranking order of the bio-fuels in specific cases. Obviously this effect is more pronounced when multiple separation processes are in place.

However from an engineering point of view it should also be considered especially at the cost-related criteria which separation process is needed because for example flash separation process may be cheaper than a typical liquid liquid extraction. For this reason at the next chapter a new separation criterion related with the cost of the process was implemented.

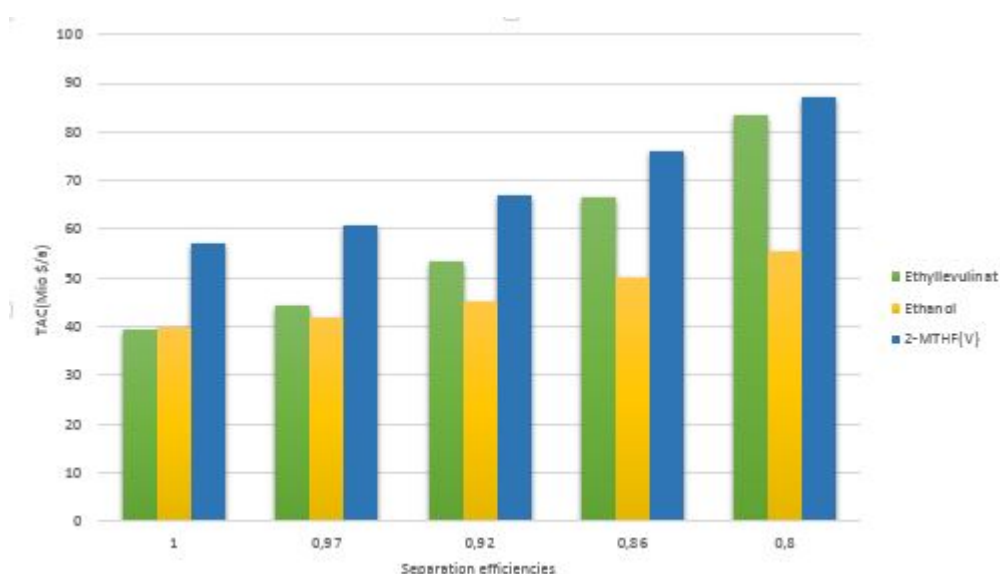

Figure 4.3.: Influence of the separation efficiencies on TAC for three promising fuel candidates

#### 4. Results and case study

In this section figures and charts should be presented so the influence of the separation processes is realized. The effect of the separation efficiency on the TAC and the environmental impact is demonstrated in figures 4.3,4.4, 4.5 and 4.6.

More in particular from figure 4.3 and figure 4.4 it can be observed that all the three pathways are affected to a significant extent. However ethanol seems to be less affected. It should be also mentioned that the ranking order does change in regard to total annualized cost which is also the case when environmental impact evaluation criteria is considered where ethyllevulinate is far more affected than ethanol. The explanation of this different behavior of ethanol and ethyllevulinate is that at the pathway for the production of ethanol only one separation is taking place while at the pathway of ethyllevulinate seven separation processes are occurring. More in particular there are six changes of solvent and one mandatory increase of concentration.

While the number of the separation processes needed for the production of the bio-fuel evidently affects the evaluation outcome of the pathway it should be also taken into account the type of the separation process as well. For example two flash separation processes may be cheaper compared to a liquid-liquid extraction where probably a distillation is needed to recycle the solvent that is used.

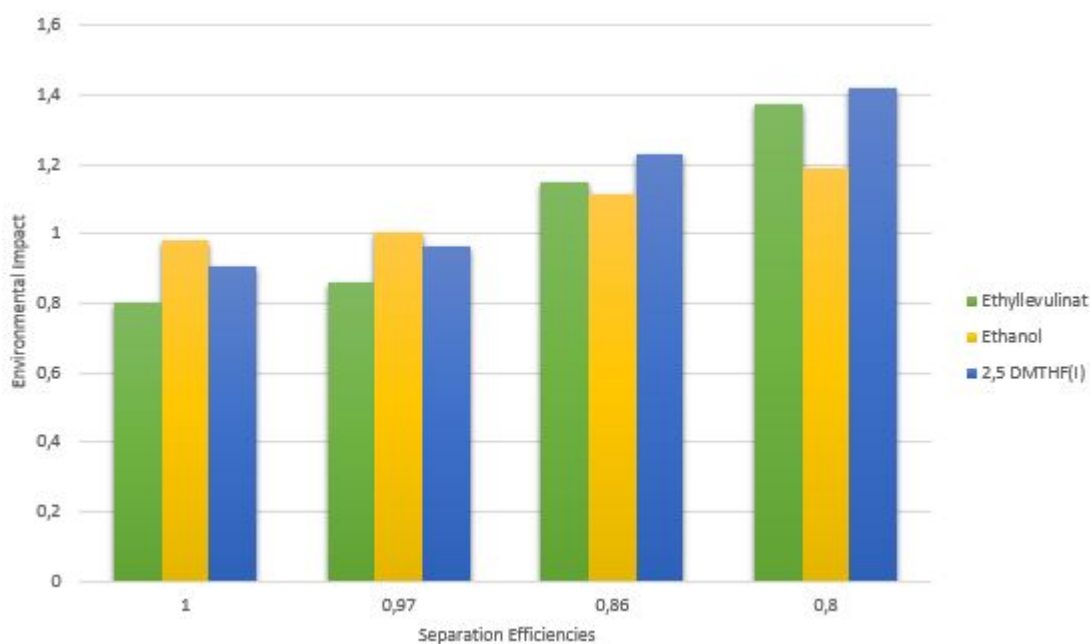

Figure 4.4.: Influence of the separation efficiencies on Environmental Impact for three promising fuel candidates

#### 4. Results and case study

In order to emphasize the influence of the separation processes, three compounds were chosen and as shown in figure 4.5 hydrogen requirements are modified in a significant way. At this stage only the number of the separations plays an important role for the ranking of the fuel candidates.

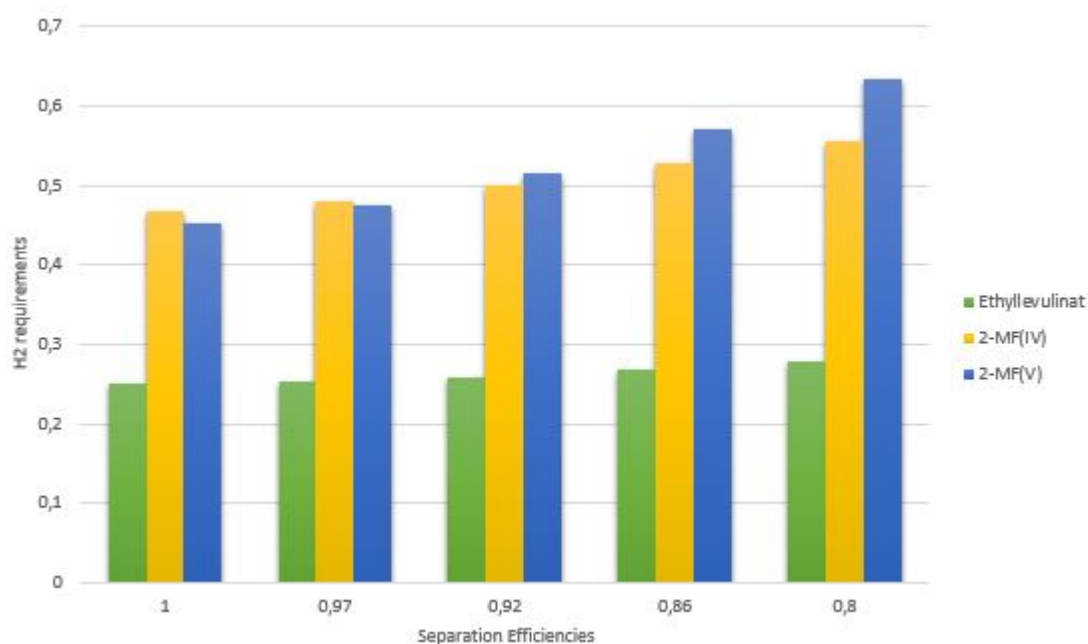

Figure 4.5.: Influence of the separation efficiencies on Hydrogen requirement

In figure 4.6 the yield (MJ/MJ fuel) seems to be also affected in a different extent for the three fuel candidates chosen.

In order to be able to evaluate the influence of the separation processes in an effective way from an early stage of design a methodology should be used to support our decision, within acceptable precision limits, which type of separation process will be adopted. At this section the fuel candidates are chosen in order to demonstrate the influence of the separation processes in an effective way. Of course there are more changes at the ranking order but the goal at this point is to realize the significance of the separation process at the evaluation.



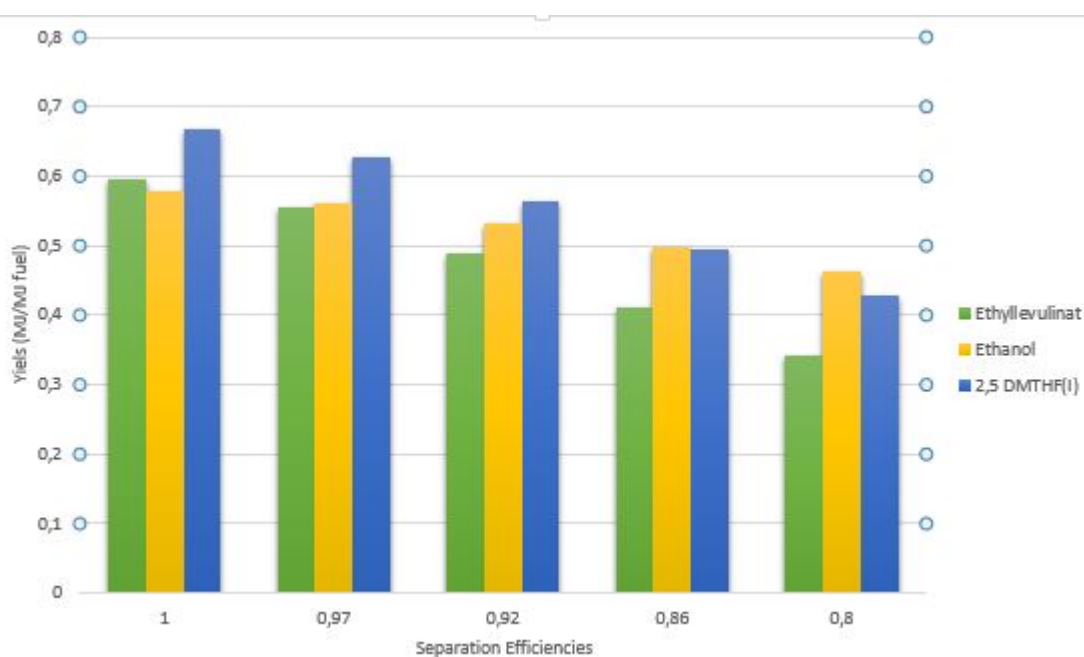

Figure 4.6.: Influence of the separation efficiencies on the yield(MJ/MJ fuel)

### 4.3. Cost and energy calculations of separation processes

At this chapter a first evaluation of the pathways is executed regarding the cost and the energy demand of the separation processes in each case. At the table 4.5 all the values of the parameters used are presented.

The calculations were executed in Matlab for every pathway and the results are presented at the tables 4.6 , 4.7. At the table 4.6 some promising pathways are exhibited while at the table 4.7 the least promising. It should be mentioned that the total cost includes the separation cost and TAC.

The promising pathways for the fuel candidates at table 4.6 can be identified because of the values of the total cost which includes also the separation cost and the energy demand which indicates how many *MJ* are needed per *MJ* that can be produced from the fuel candidate. For the case of ethanol and butanol only two separations are faced. The first is about increasing the concentration of glucose in order to make its fermentation feasible and the second concerning the separation of water and ethanol is relatively cheap with limited energy demands. Regarding 3-MTHF the total cost is higher than the two previous cases however the separations cost and

#### 4. Results and case study

Parameters	Values	Units
Separation efficiency	0.97	-
Water price	0.27	\$/tonne
Octanol price	500.5	\$/tonne
Rule of thumb constant <sub>1</sub>	1.3	-
Rule of thumb constant <sub>2</sub>	0.5	-
Rule of thumb constant <sub>3</sub>	0.05	-
Electricity price	70	\$/MWh
Steam price	36	\$/MWh
Cooling water	1.61	\$/MWh
Refrigeration	42	\$/MWh
Solvent losses	5%	-

Table 4.5.: Parameters values[25] , [2]

Fuel candidate	Total cost(\$/MJ fuel)	Percent of separation cost	Energy demand(MJ/MJ fuel)	Primary energy demand
Ethanol	$7.95 * 10^{-6}$	36%	0.165	$6.8 * 10^{11}$
Butanol	$9.51 * 10^{-6}$	24%	0.21	$8.8 * 10^{11}$
3-MTHF	$1.58 * 10^{-5}$	2%	0.026	$5.5 * 10^{10}$
THF	$1.74 * 10^{-5}$	15%	0.21	$5.5 * 10^{11}$

Table 4.6.: Promising fuel candidates

the energy demand for the separations processes is relatively low. The reason for this result is that for the crystallization to separate water and itaconic acid cooling water is used until 30°C. Tetrahydrofuran's production pathway has four separation processes:

1. water-furfural
2. Hydrogen-furan
3. Water-succinic acid
4. Increase of the concentration of glucose

For the first binary mixture distillation is used because of the high concentration of furfural the amount of the water that is needed to be vaporized. For the two other binary mixtures the temperature is decreased mainly with cooling water. In conclusion the separation processes at this occasion are not costly which is not the case for table 4.7.

#### 4. Results and case study

The main reason for the high cost of these pathways is the water - fructose separation where all the water needs to be evaporated and this really influences the steam required. For the case of 2-MF(I) the separation of water and methylfurfural is expensive for the same reason.

Fuel candidate	Total cost(\$/MJ fuel)	Percent of separation cost	Energy demand(MJ/MJ fuel)	Primary energy demand
2-MF(I)	$5.35 * 10^{-5}$	88%	2.45	$8.7 * 10^{12}$
2-MF(II)	$5.23 * 10^{-5}$	75%	2.74	$1.1 * 10^{12}$
2-MTHF(I)	$2.74 * 10^{-5}$	54%	1.74	$5.5 * 10^{10}$

Table 4.7.: Fuel candidates that can be excluded

At the table 4.8 two different cases with high cost are presented. For ethyllevulinate the relatively high cost of the separation processes is a result of the seven separation processes needed for its production. At the case of 2,5 DMTHF(I) only two separations are taking place. However they are both costly. First a water - fructose separation is needed and then a liquid-liquid extraction for the water and 2,5 DMTHF (I) is necessary which is followed from a distillation to obtain the solvent. However they are both costly. First a water - fructose separation is needed and then an liquid-liquid extraction for the for water and 2,5 DMTHF (I) is necessary which is followed from a distillation to obtain the solvent.

Fuel candidate	Total cost(\$/MJ fuel)	Percent of separation cost	Energy demand(MJ/MJ fuel)	Primary energy demand
2,5 DMTHF(I)	$4.67 * 10^{-5}$	73%	0.77	$3.1 * 10^{12}$
Ethyllevulinate	$1.74 * 10^{-5}$	64%	0.84	$3.3 * 10^{12}$

Table 4.8.: More fuel candidates

At the figure 4.7 the ranking of all the fuel candidates is presented concerning only the separation costs and the separation energy demand.

## 4. Results and case study

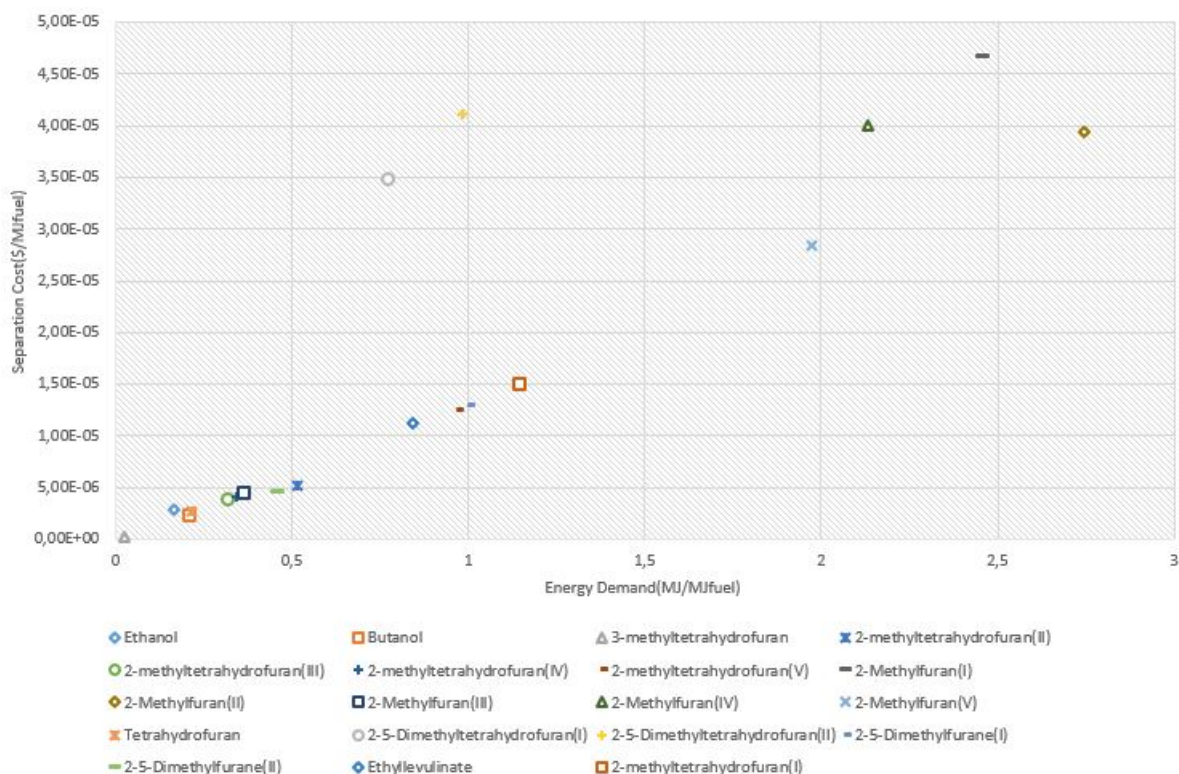

Figure 4.7.: Ranking of the fuel candidates regarding the separation processes

### 4.4. Sensitivity analysis

At the previous sections all the parameters used are mentioned and the results generated are also presented. However it should be pointed out that the values of the parameters-variables may differ from place to place like the electricity price or may have uncertainties like the constants of the rule of thumb. For these reasons a sensitivity analysis is carried out to clarify the influence of possible changes at the parameters at the results.

Generally for the sensitivity analysis of this work more than 20 values are tested between the limits presented at the table 4.9. The separation efficiencies consist an exception as only four values are tested like in the previous chapter.

The results are presented selectively for the fuel candidates that are significantly influenced for all parameters, which are classified in groups.

#### 4. Results and case study

Parameters	Upper limit	lower limit
Separation efficiency	0.97	0.8
Water price	0.29	0.25
Octanol price	528	475
Rule of thumb constant <sub>1</sub>	1.5	1.08
Rule of thumb constant <sub>2</sub>	0.7	0.28
Rule of thumb constant <sub>3</sub>	0.07	0.028
Electricity price	87	57
Steam price	44	29
Cooling water	2	1.3
Refrigeration	52	34
Solvent losses	10%	0%

Table 4.9.: Parameters values for the sensitivity analysis

#### 4.4.1. Prices of utilities

The energy demand is covered from different utilities for every separation process. For example crystallization needs cooling water until 30°C and then refrigeration to 0°C, while for distillation steam is the utility needed.

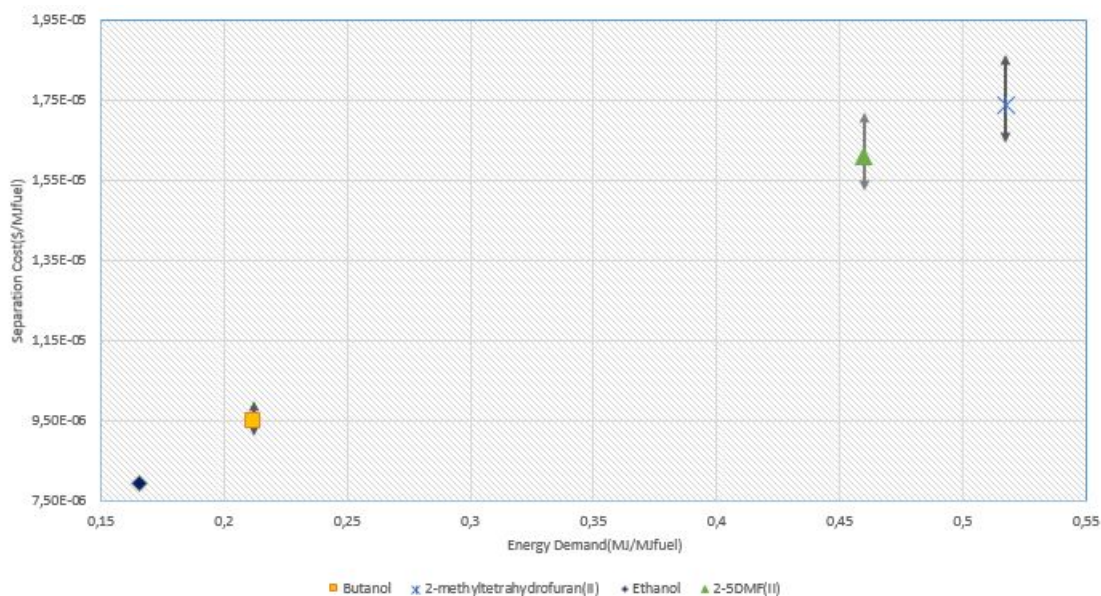

Figure 4.8.: How steam price affects some fuel candidates

At the figure 4.8 the influence of the steam price on some promising fuel candidates is presented. The pathways which are affected by the price of steam are those where distillation ,

## 4. Results and case study

azeotropic distillation or flash is used. However the extent of the influence depends on the amount of the compound that needs to be vaporized.

At the figure 4.9 it is demonstrated how the electricity price affects some of the fuel candidates. The electricity price affects only the pathways in which flash separation process is used. The influence is relatively important as generally electricity is the most expensive utility in comparison with all the utilities used.

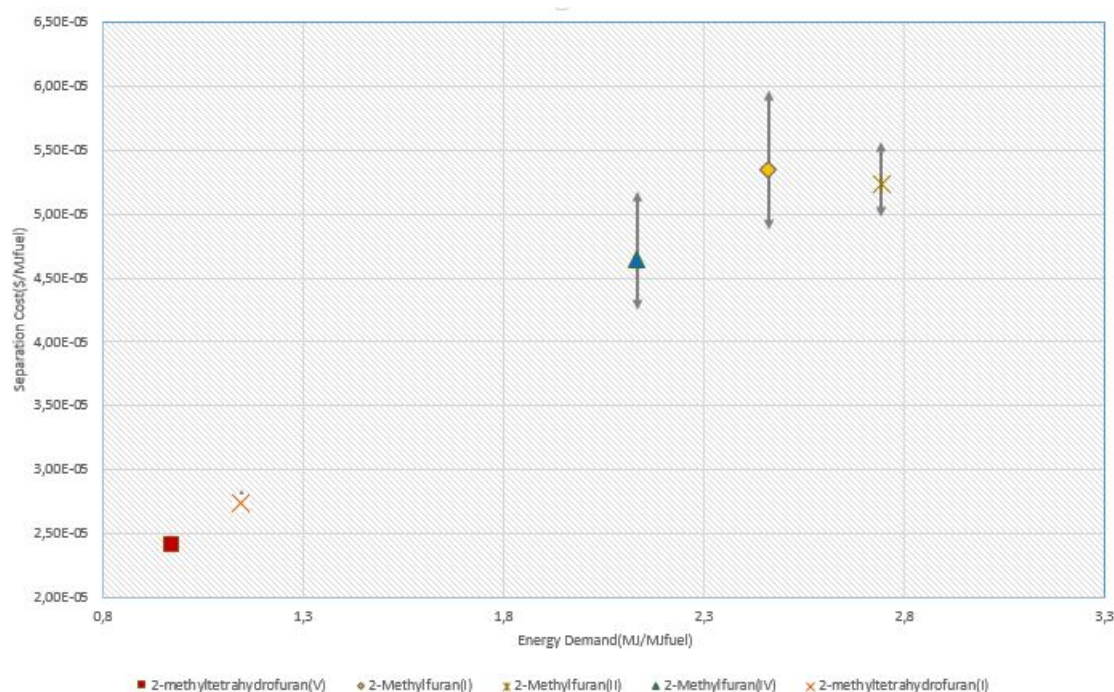

Figure 4.9.: How electricity price affects some fuel candidates

The price of cooling water does not alter the separation cost significantly as it is in every case really small in comparison to the prices of the other utilities. Regarding refrigeration, even if the price is relatively high, it is used in a very small extent so the influence again is not significant. In numbers for both cases the values calculated at the first case do not alter more than 0.5%.

### 4.4.2. Rule of thumb constants

As mentioned at the previous chapter the rule of thumb is used in order to estimate the energy needed for distillation and flash separation process. So changes at the values of the constants

#### 4. Results and case study

of this approach will affect the pathways in which these separation processes are used more or for bigger amounts of the compounds.

The constant regarding distillation which has the value of 1.3 [12] is affecting the fuel candidates which need distillation or azeotropic distillation to be produced. In figure 4.10 it can be noticed that fuel candidates which have two or more distillations or azeotropic distillations at its pathway are more affected than fuels like ethanol or THF which have one separation process affected by the constant of the equation 3.5.

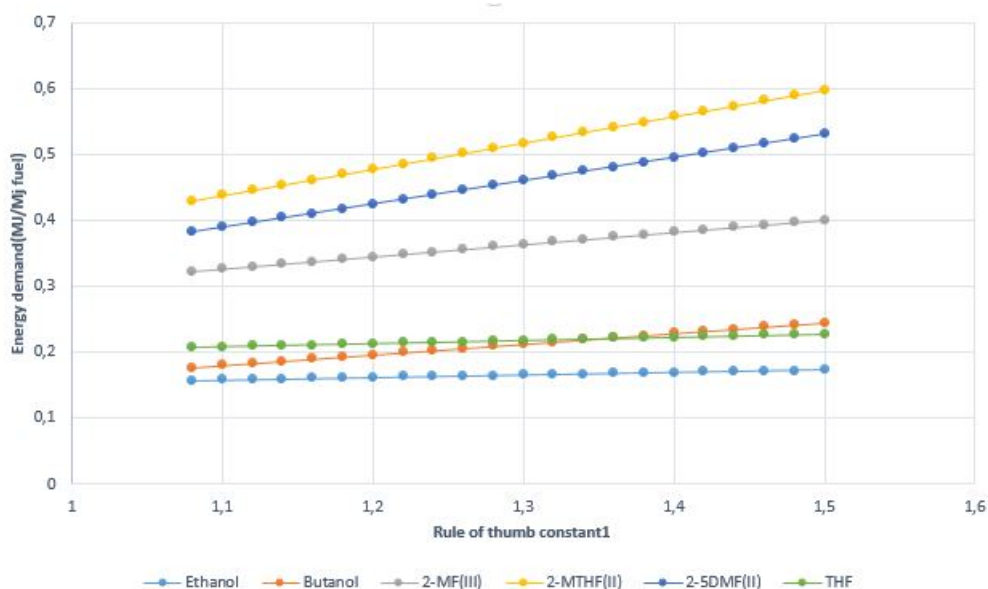

Figure 4.10.: Influence at the results of the constant concerning distillation steam requirements

The other two constants are used only in pathways in which flash separation process is needed. Two remarks should be made at this point. First when comparing the figures 4.11 and 4.12 it can be perceived that the constant regarding the steam requirement has more significant influence on the energy demand.

#### 4. Results and case study

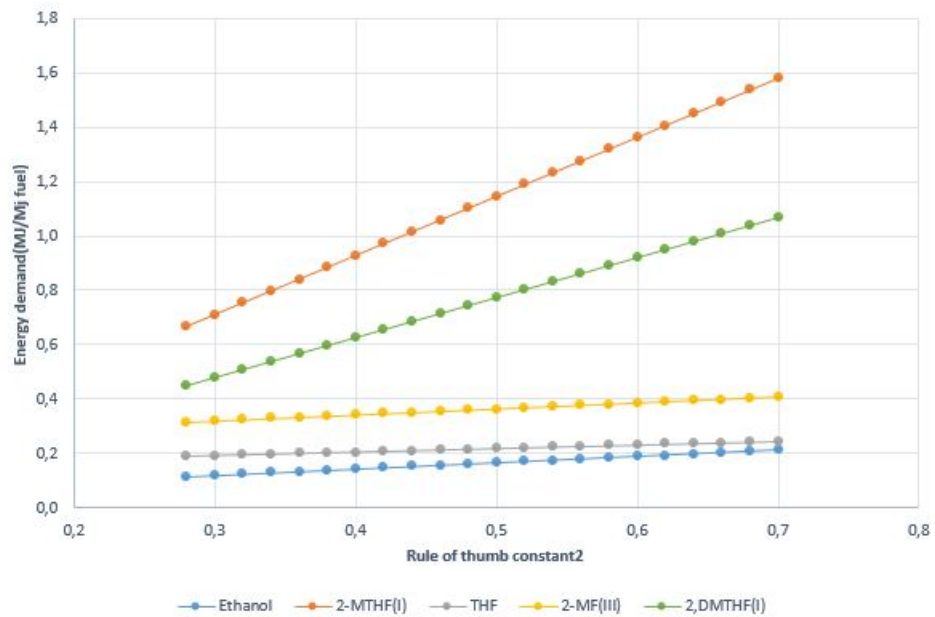

Figure 4.11.: Influence at the results of the constant concerning flash steam requirements

The explanation is that the value of the constant regarding the steam requirement is ten times bigger than the constant regarding the electricity requirement.

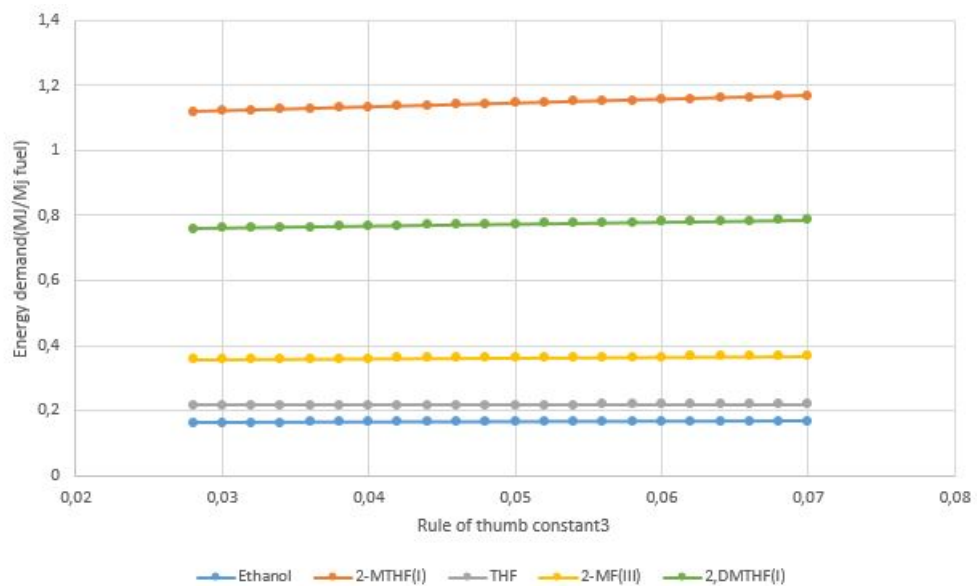

Figure 4.12.: Influence at the results of the constant concerning electricity requirement

The second observation concerns the fuel candidates that are more affected than others from



the change of the same parameter. For example 2-MTHF(I) and 2,5DMTHF(I) are more affected because the equations 3.6 and 3.7 are used for more than one separation for considerable amounts of compounds. More specifically at the case of 2-MTHF(I) two flash separation processes are needed that are both costly mainly because of the considerable amounts of the compounds that need to be separated. In figure 4.12 it can be observed that the influence of the constant regarding the electricity demand is not so critical.

### 4.4.3. Solvent price and solvent losses

At the network introduced at this work there are only two fuel candidates that are affected from changes concerning the solvents. The reason is that only for two fuel candidates liquid-liquid extraction is used for their production, and actually only one binary system is separated with liquid-liquid extraction. However it should be mentioned that only the solvent losses affect in a significant way the total cost of the pathways.

The solvent losses affect the total cost substantially and alter the position of the two fuel candidates as shown in figure 4.13.

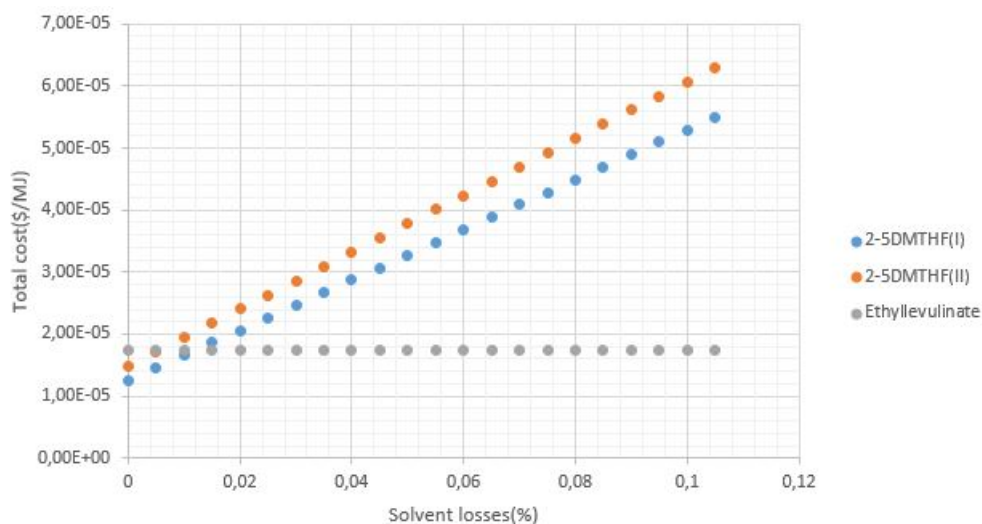

Figure 4.13.: Solvent losses influence on the total cost of some fuel candidates

Regarding the solvent prices the influence is not significant considering 10% change at the price of octanol. In numbers the influence is about 3% considering a normal change at the price of octanol.

#### 4.4.4. Separation efficiencies

This parameter is directly connected with the amount of the compounds that need to be separated and as a consequence with the biomass needed to be used at first. In other words if at a separation process the goal is to produce a specific amount of product but the separation efficiency is, for example, 92% that means that educt needed is increased in comparison to ideal separation or separation efficiencies close to 100%, where the amount of the educt depends only on the efficiency of the chemical process. Moreover if a pathway has more than one separation processes this logic works as a chain and finally the need of biomass is increased as well as the amount of the educt for all the chemical and separation processes.

At figure 4.14 it is demonstrated the effect of the separation efficiencies on various fuel candidates regarding the total cost and the energy demand.

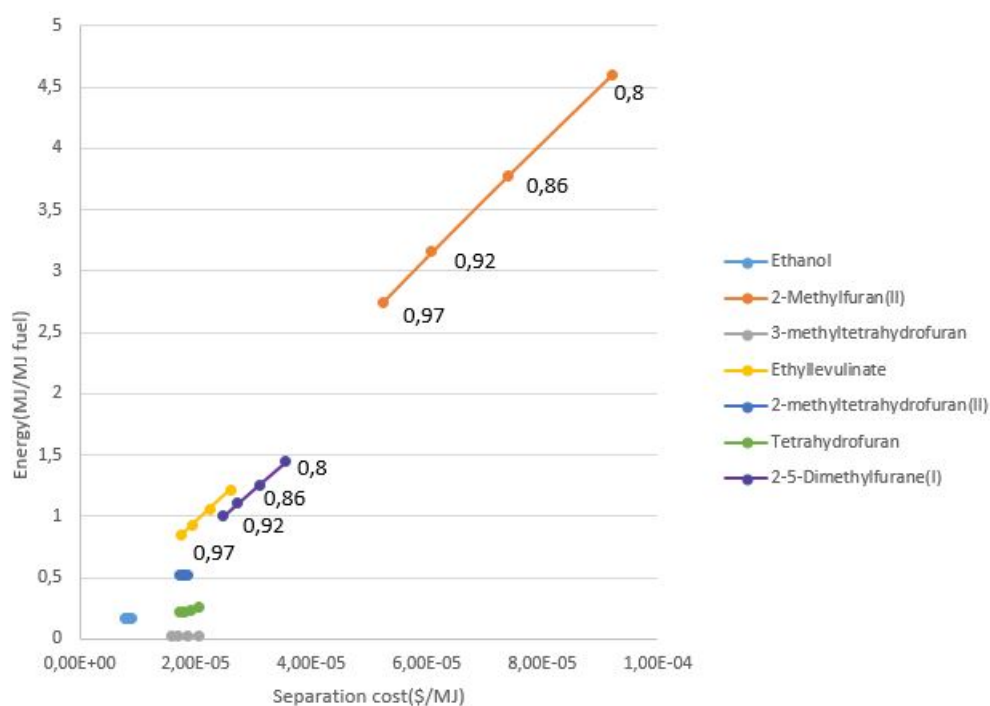

Figure 4.14.: Separation efficiency influence on the cost and the energy demand

Fuel candidates like ethanol or 3-MTHF are not significantly affected as their pathways do not have so many separation processes and the cost of this processes is not affected that much from the quantities that are needed to be separated. From the other side fuel candidates like 2-MF(II) and 2,5DMF(I) are significantly influenced as their pathways have more separation

processes and the energy demand is dependent on the already considerable amounts of the compounds that need to be, in most cases, evaporated.

#### 4.4.5. Energy demand deviation for the most promising fuel

From the previous sections it can be observed that every different parameter affects the evaluation criteria of the fuel candidates in a different extent. In figure 4.15 the most promising fuel candidates and the highest deviation found at the sensitivity analysis are plotted and at the table 4.15 the parameter that affects most the energy demand of the fuel candidate is presented. For the case of 3-MTHF which is the most promising in the context of separation processes the influence from every single parameter is insignificant. It is plotted just to picture the difference from the other fuel candidates.

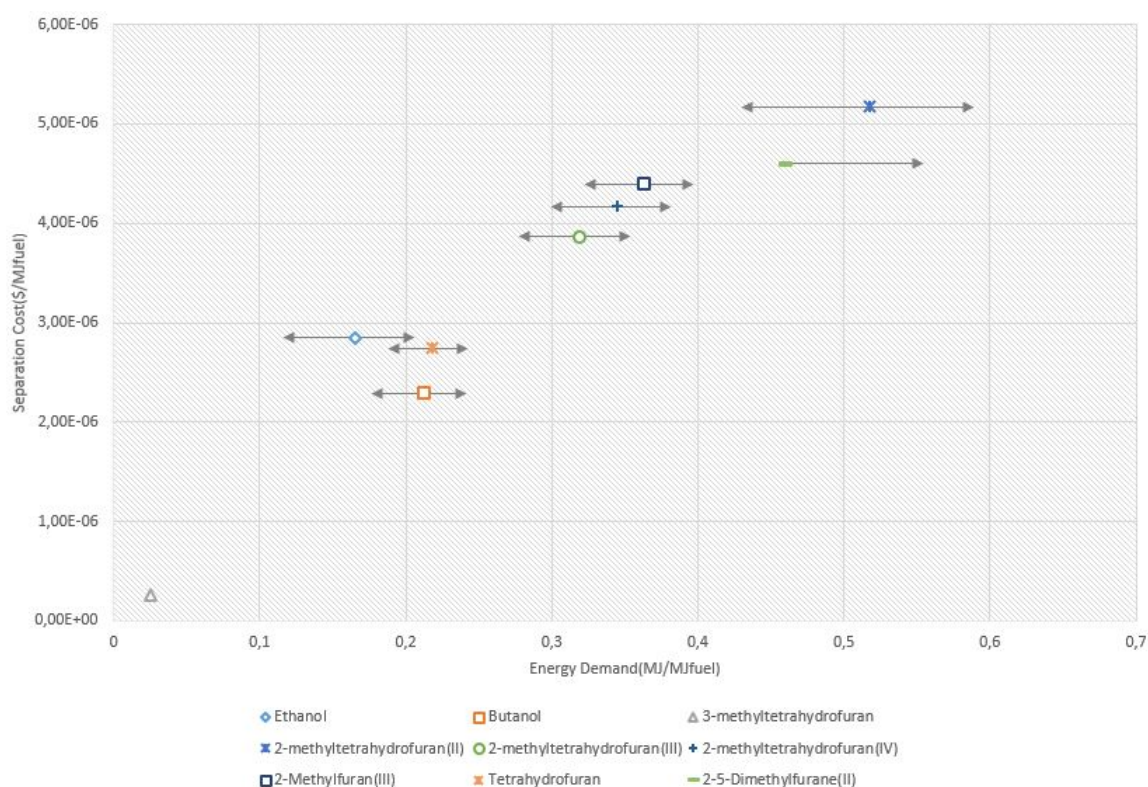

Figure 4.15.: Energy demand deviation for the most promising fuel candidates

The following table depicts the parameters that cause this deviation to the fuel candidates of figure 4.15.

Fuel candidates	Parameter with the most significant influence
Ethanol	Rule of Thumb Constant <sub>2</sub>
THF	Rule of Thumb Constant <sub>2</sub>
Butanol	Rule of Thumb Constant <sub>1</sub>
2-MTHF(III)	Rule of Thumb Constant <sub>2</sub>
2-MTHF(IV)	Rule of Thumb Constant <sub>2</sub>
2-MF(III)	Rule of Thumb Constant <sub>1</sub>
2,5DMF(II)	Separation Efficiencies
2-MTHF(II)	Rule of Thumb Constant <sub>1</sub>

Table 4.10.: Parameter with the most significant influence for the most promising fuel candidates

#### 4.4.6. Boundaries of split factors

A sensitivity analysis was carried out also for the boundaries of the split factors and it was found out that there are two binary systems, the separations of which, are not feasible after a 3% of change of the boundaries. These binaries systems are as follows:

1. dioxane - 3-MTHF (distillation)
2. water - succinic acid (crystallization)

### 4.5. Monte carlo analysis

From the previous section it can be concluded that all the parameters examined have an influence on the results. They do not always alter the ranking but the effect can't be ignored. Therefore it can be useful to use monte carlo analysis and combine in a random way the parameters within the limits presented in the table 4.9.

For the monte carlo analysis according to the Joint Research Center of the European Commission the number of the Monte Carlo experiments should be at least ten times the number of the model parameters. At this work the number of the parameters is eleven so the experiments should be at least 110 [19]. For the ensurance of the evaluation 150 experiments are done.

At first the behavior of some of the most promising fuel candidates is presented and then compare one or two of them with other fuel candidates which are more sensitive at the changes of the parameters.

#### 4. Results and case study

In figure 4.17 the behavior of the most promising fuel candidates is demonstrated.

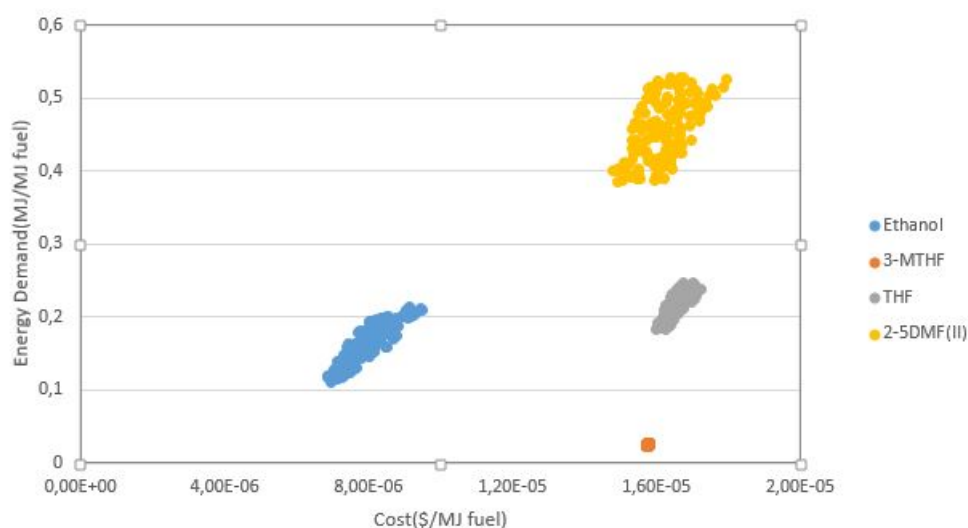

Figure 4.16.: Monte Carlo analysis results for promising fuel candidates

From the other side fuel candidates that already have high costs and high energy demand tend to be more sensitive at this kind of changes of the parameters. Generally, the candidates that have more separation processes at its production tend to be more sensitive. In other words the more separation processes a pathway includes the more parameters are used and as a result the sensitivity of the final results at the monte carlo analysis is higher. Moreover the pathways in which bigger amounts of compounds are needed to be separated tend to be more sensitive because the parameters have a direct relation with the amounts as shown at the equations of the previous chapter concerning the methodology of the calculations.

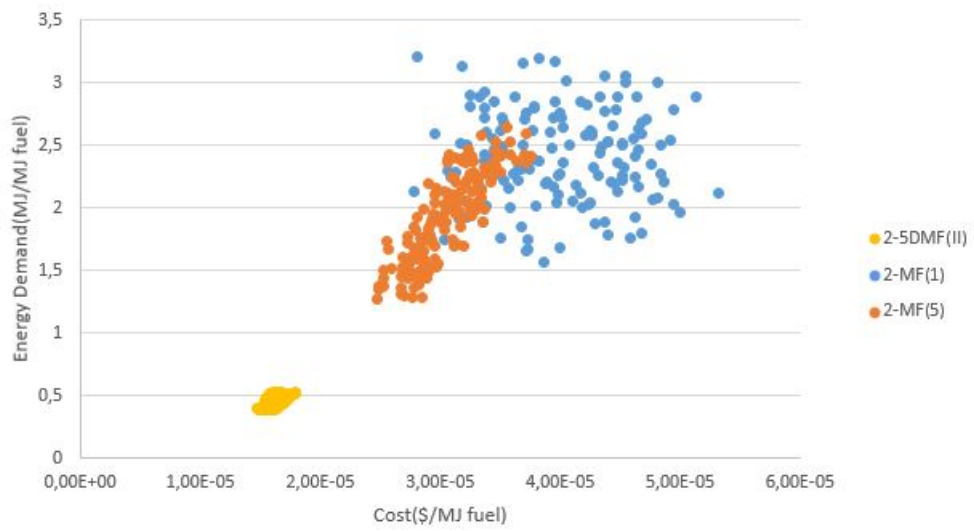

Figure 4.17.: Monte Carlo analysis results for 2-MF(I) and 2-MF(V) in comparison to 2,5DMF(II)

## 5. Conclusions and future steps

Plenty of scientists argue that biofuels will dominate the energy domain the next years. This diploma thesis intends to contribute at the selection of fuel candidates in an early stage design of a biorefinery. The goal of this work is the creation of a methodology able to be implemented in every reaction network similar to the one examined here. It is believed that the goal of the general applicability of the methodology is achieved as it is proven from this network. The only requirement is the properties of the compounds existing in the network. There was an effort for the methodology to be fast and effective, even if it is difficult to combine these two characteristics. However after the sensitivity analysis it is proven that the results can be reliable in an early stage design because the ranking order did not alter in an utmost extent after the monte carlo analysis.

In addition some simple and safe conclusions should be underlined:

1. The number of the separation processes is an important factor.
2. The amounts of the compounds that need to be separated play a substantial role at the result.
3. The criterion introduced works only complementary to the other criteria already used by Voll et al. [26]

Of course also the vulnerabilities should be mentioned. The models which are used for the calculations did not really cause significant uncertainties for an early stage design as proven by the monte carlo analysis. However there are some things concerning mainly the split factors that cause uncertainties. The following list highlights the most crucial.

1. The possibility of implementing other types of azeotropic distillation should be examined because at this work all the azeotropic distillations are considered as pressure swing distillations.

## 5. Conclusions and future steps

---

2. Binary systems like fructose and water should be examined again because with the separation process proposed from the code the cost is really high. Maybe there are other more complex separation processes that are feasible.

The most important remark concerns the boundaries for the feasibility of the separation processes. The boundaries used, both from Jaksland[13] and for the feasibility of the crystallization, have uncertainties. For example for the binary mixture of dioxane and 3-MTHF was proven that distillation is not feasible after a change of 3% of the boundaries. The same observation was made for water and succinic acid. After a change of 3% of the boundaries crystallization was not feasible.

Taking into consideration the lean thinking approach which is recently evolved as flexible and agile manufacturing, a future window of opportunity could be the implantation of the above mentioned engineering concept in the production of biofuel. For example two or more biofuels could be produced from the same raw materials or the same biofuel can be produced from two or more pathways. The plant could be able to adopt its production to the market demands.



# Appendices

# A. Appendix

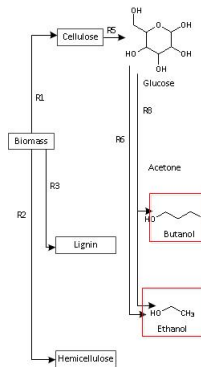

Figure A.1.: Ethanol and butanol pathways

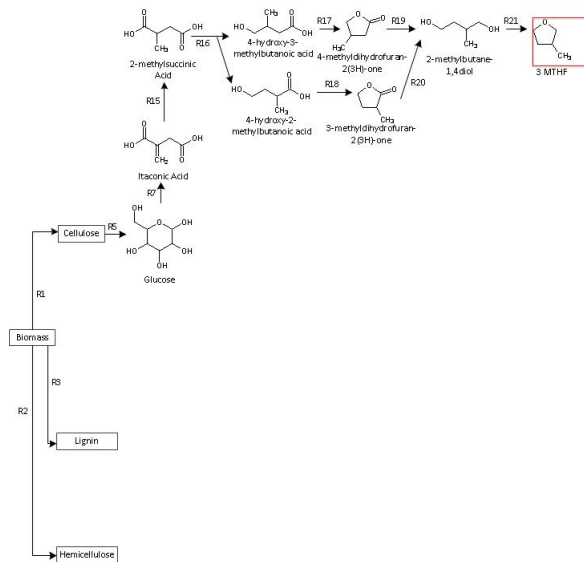

Figure A.2.: 3-MTHF pathway

## A. Appendix

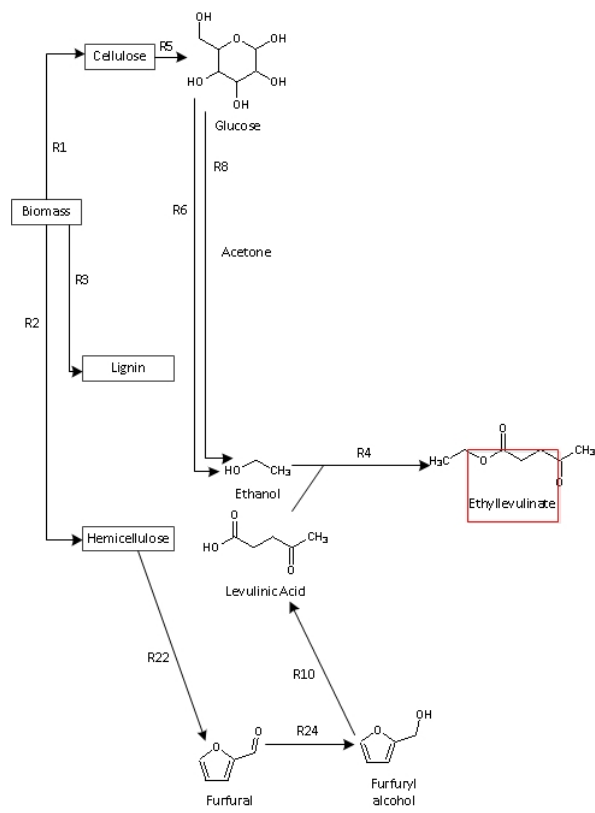

Figure A.3.: Ethyllevulinate pathway

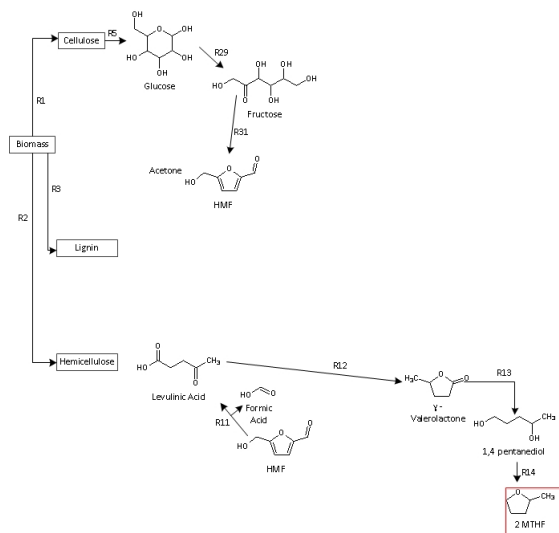

Figure A.4.: 2-MTHF(I) pathway

## A. Appendix

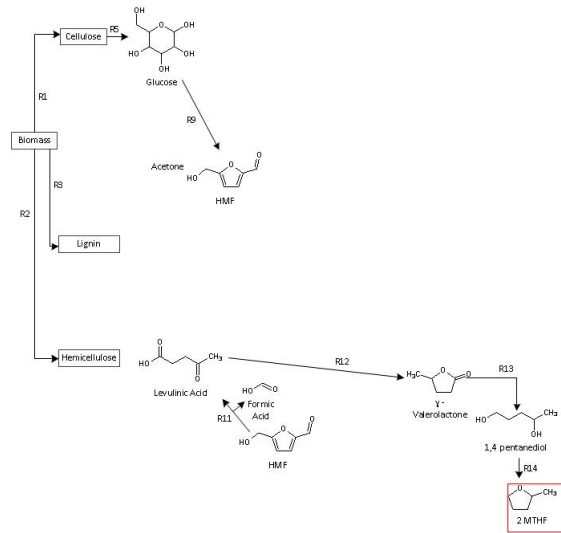

Figure A.5.: 2-MTHF(II) pathway

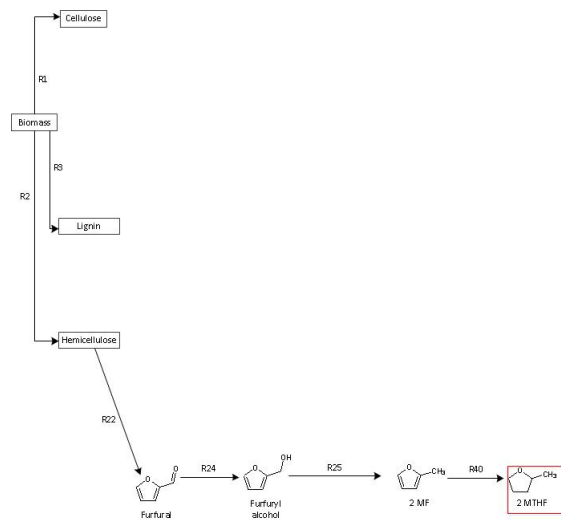

Figure A.6.: 2-MTHF(III) pathway

## A. Appendix

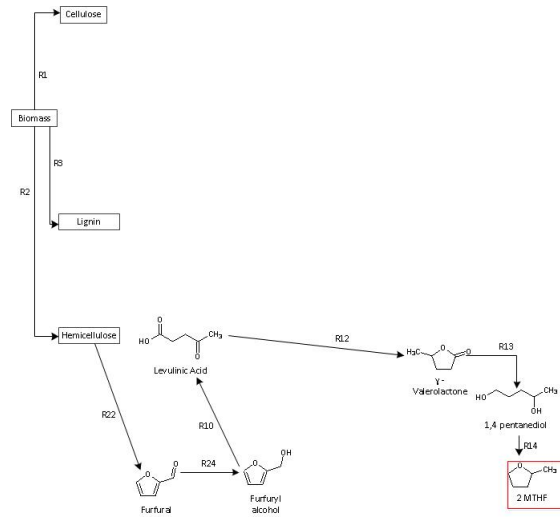

Figure A.7.: 2-MTHF(IV) pathway

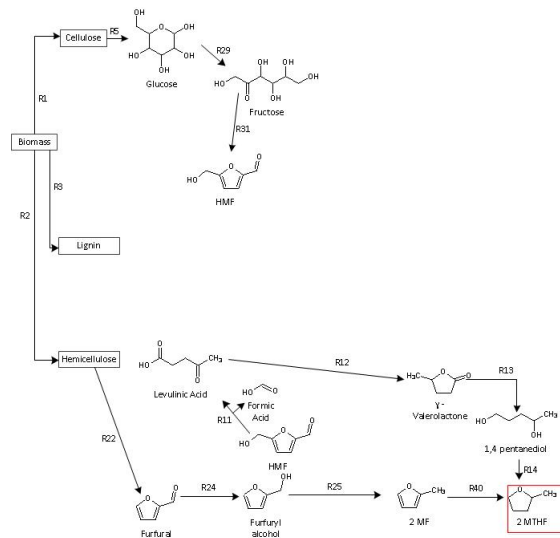

Figure A.8.: 2-MTHF(V) pathway

## A. Appendix

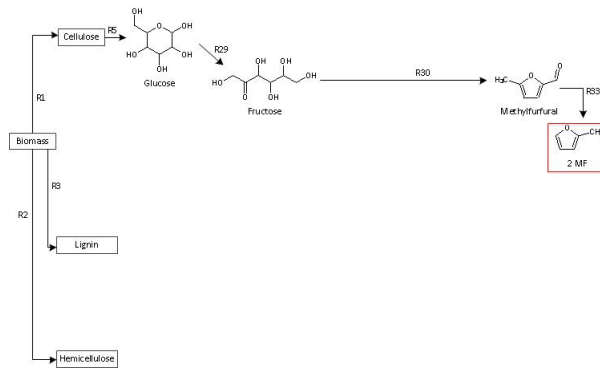

Figure A.9.: 2-MF(I) pathway

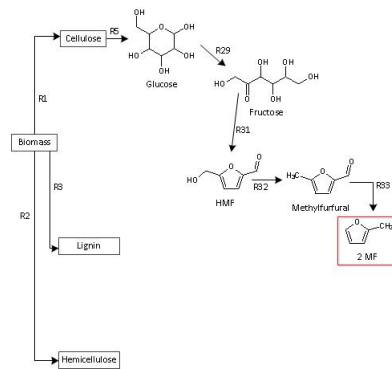

Figure A.10.: 2-MF(II) pathway

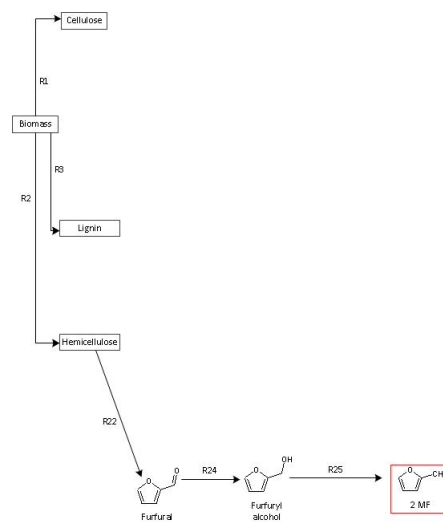

Figure A.11.: 2-MF(III) pathway

## A. Appendix

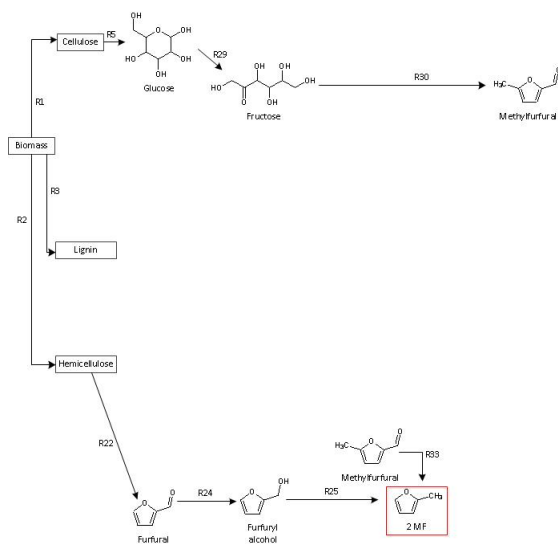

Figure A.12.: 2-MF(IV) pathway

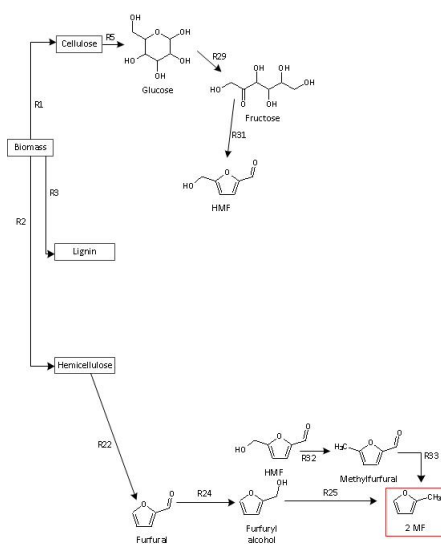

Figure A.13.: 2-MF(V) pathway

## A. Appendix

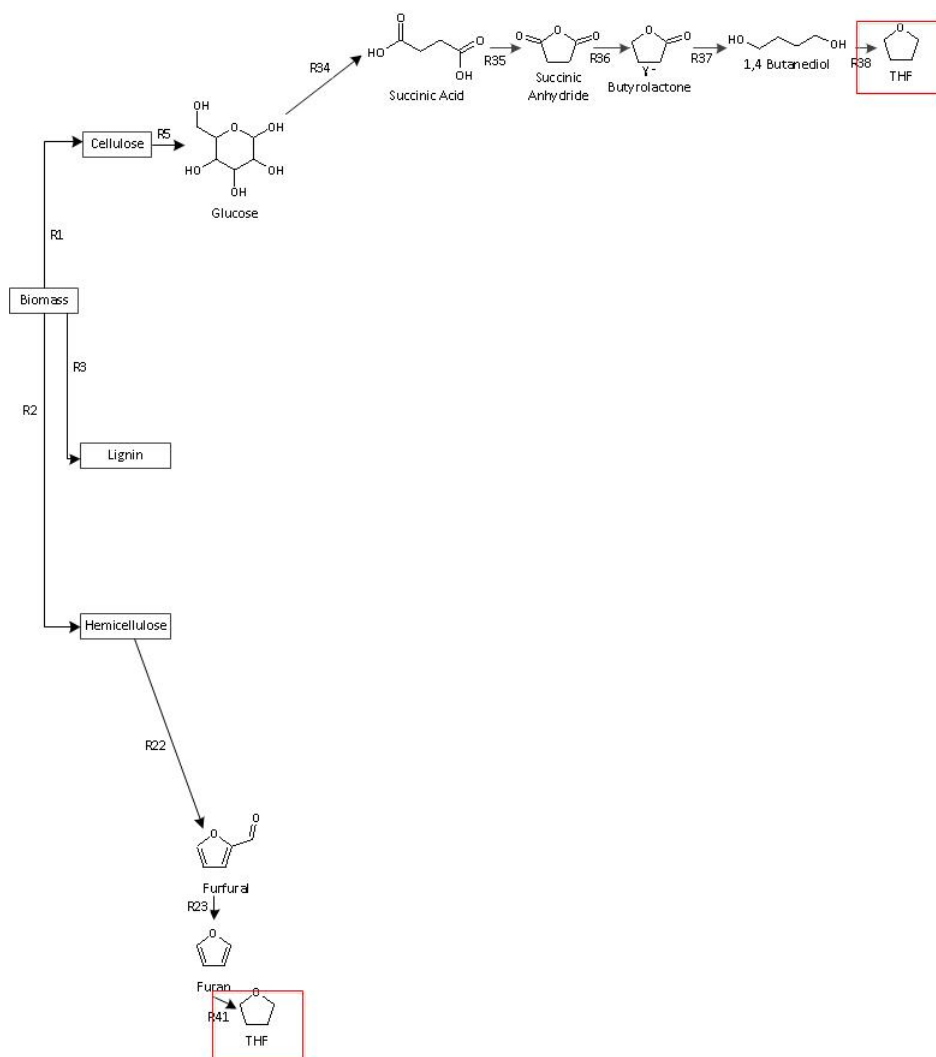

Figure A.14.: THF pathway

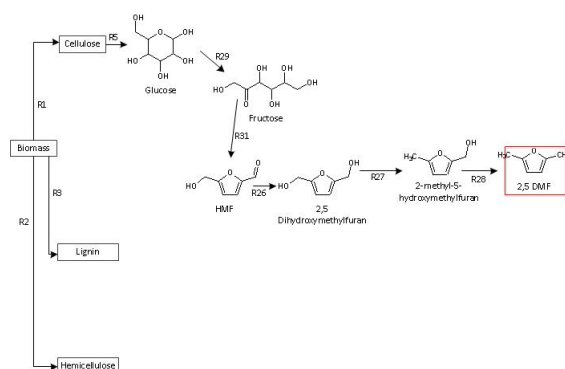

Figure A.15.: 2,5DMF(l) pathway



## A. Appendix

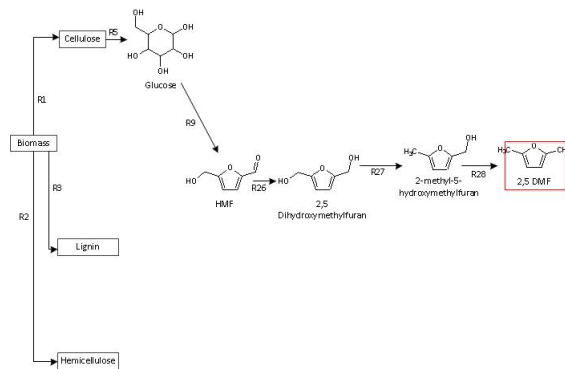

Figure A.16.: 2,5DMF(II) pathway

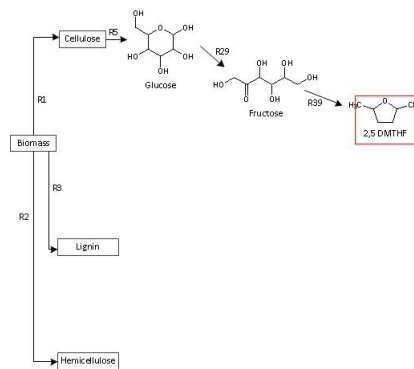

Figure A.17.: 2,5DMTHF(I) pathway

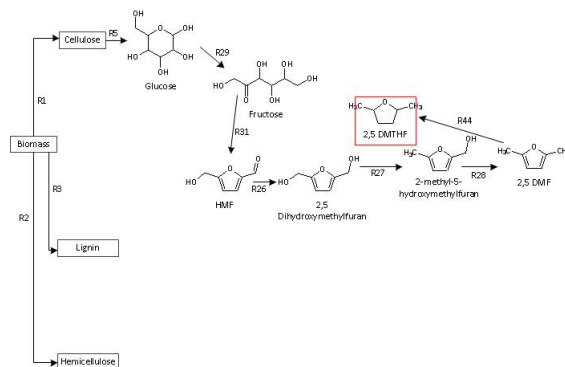

Figure A.18.: 2,5DMTHF(II) pathway

## Bibliography

- [1] W. Marquardt A. Voll. Reaction network flux analysis: Optimization-based evaluation of reaction pathways for biorenewables processing. *AIChE J. (AIChE Journal)*, page 17881801, 2012.
- [2] Alibaba, 2013. Available at <http://www.alibaba.com/showroom/octanol.html>.
- [3] Inc. Aspen Technology. Aspen physical property system physical property models v7.3.2.
- [4] Lorenz T Biegler, Ignacio E Grossmann, and Arthur W Westerberg. Systematic methods for chemical process design. 1997.
- [5] Prodromos Daoutidis, W. Alex Marvin, Srinivas Rangarajan, and Ana I. Torres. Engineering biomass conversion processes: A systems perspective. *AIChE Journal*, 59(1):3–18, 2013.
- [6] Wiebren De Jong and Gianluca Marcotullio. Overview of biorefineries based on co-production of furfural, existing concepts and novel developments. *International journal of chemical reactor engineering*, 8(1), 2010.
- [7] Ecoinvent. Lci datasets lcia results, 2013. Available at <http://www.ecoinvent.org/database/ecoinvent-version-3/how-to-use-ecoinvent-3>
- [8] Apelblat et al. Solubility of oxalic, malonic, succinic, adipic, maleic, malic, citric, and tartaric acids in water from 278.15 to 338.15 k. *J. Chemical Thermodynamics*, 1987.
- [9] Apelblat et al. Solubilities of l-aspartic, dl-aspartic, dl-glutamic, p-hydroxybenzoic, o-anistic, p-anistic, and itaconic acids in water from t=278 k to t=345k. *J. Chemical Thermodynamics*, 1997.
- [10] EuropaBio. Biorefinery feasibility study, 2011. Available at <http://www.europabio.org/biorefinery-feasibility-study>.

- [11] Carlos A. Henao. *A Superstructure Modeling Framework for Process Synthesis Using Surrogate Models*. University of Wisconsin at Madison, Madison, WI, USA, 2012. AAI3508825.
- [12] B. G. Hermann and M. Patel. Today's and tomorrow's bio-based bulk chemicals from white biotechnology. *Science, Technology Society*, 2006.
- [13] Cecilia A Jaksland, Rafiqul Gani, and Kristian M Lien. Separation process design and synthesis based on thermodynamic insights. *Chemical Engineering Science*, 50(3):511–530, 1995.
- [14] Andreas J. Janssen, Florian W. Kremer, Jan H. Baron, Martin Muether, Stefan Pischinger, and Juergen Klankermayer. Tailor-made fuels from biomass for homogeneous low-temperature diesel combustion. *Energy & Fuels*, 25(10):4734–4744, 2011.
- [15] Irena Krivankova, Maja Marcisinova, and Otakar Sohnel. Solubility of itaconic and kojic acids. *Journal of Chemical and Engineering Data*, 37(1):23–24, 1992.
- [16] Jean-Paul Lange. Fuels and chemicals manufacturing; guidelines for understanding and minimizing the production costs. *Cattech*, 5(2):82–95, 2001.
- [17] JW Lee, S Huan, KM Lien, and AW Westerberg. A graphical method for designing reactive distillation columns. ii. the mccabe-thiele method. In *Proceedings of the Royal Society of London A: Mathematical, Physical and Engineering Sciences*, volume 456, pages 1965–1978. The Royal Society, 2000.
- [18] Ho-Mu Lin, Hsin-Yi Tien, Ying-Tzu Hone, and Ming-Jer Lee. Solubility of selected dibasic carboxylic acids in water, in ionic liquid of [bmim][bf 4], and in aqueous [bmim][bf 4] solutions. *Fluid Phase Equilibria*, 253(2):130–136, 2007.
- [19] Jason L Loeppky, Jerome Sacks, and William J Welch. Choosing the sample size of a computer experiment: A practical guide. *Technometrics*, 51(4), 2009.
- [20] Warren L McCabe and EW Thiele. Graphical design of fractionating columns. *Industrial & Engineering Chemistry*, 17(6):605–611, 1925.
- [21] Muhammad Rizwan, Jay H. Lee, and Rafiqul Gani. Optimal processing pathway for the production of biodiesel from microalgal biomass: A superstructure based approach. *Computers & Chemical Engineering*, 58:305–314, 2013.

## Bibliography

---

- [22] Fuelcenter RWTH. Tailor-made fuels from biomass, 2014. Available at <http://www.fuelcenter.rwth-aachen.de/index.php?id=341&L=2>.
- [23] Dr. Stathis Skouras. Azeotropic distillation methods, 2014. Available at [http://www.chemeng.ntua.gr/courses/mad/files/Azeotropic%20distillation\\_Decemb](http://www.chemeng.ntua.gr/courses/mad/files/Azeotropic%20distillation_Decemb)
- [24] J Urbanus, CPM Roelands, D Verdoes, and JH ter Horst. Intensified crystallization in complex media: Heuristics for crystallization of platform chemicals. *Chemical Engineering Science*, 77:18–25, 2012.
- [25] Jörn Viell, Andreas Harwardt, Jan Seiler, and Wolfgang Marquardt. Is biomass fractionation by organosolv-like processes economically viable? a conceptual design study. *Bioresource technology*, 150:89–97, 2013.
- [26] Anna Voll. *Model-based Screening of Reaction Pathways for Processing of biorenewables*. 2013.