



NATIONAL TECHNICAL UNIVERSITY OF ATHENS  
SCHOOL OF MINING AND METALLURGICAL ENGINEERING

Master thesis

# **Comparative Analysis between Drill and Blast and Mechanical Excavation in Underground Construction**

## **Supervisor**

Andreas Benardos  
Associate Professor

## **Student**

Pedro Costa Feijóo

Athens 2019

*Abstract*

The selection of the excavation method to be used is a challenging task as there are a lot of different parameters to be considered, while on the same time there are unique characteristics in each project. In this thesis, a methodology for the selection of the most suitable method between drill and blast and mechanical excavation is presented, based on the cost and the timing of the excavating operations. In order to further analyse the influence of rock mass characteristics, the cost variation with respect to the rock mass quality has been analysed, allowing the selection of the most suitable method. Finally, in order to address uncertainty issues, a probabilistic analysis using the Monte Carlo simulation has been also incorporated.

## Table of Content

1. Introduction and Objectives .....	4
2. Background and Literature Research.....	5
3. Excavation .....	9
3.1. Excavation Parameters.....	9
3.1.1. Excavability .....	11
3.1.2. Drillability .....	18
3.2. Types of Excavation .....	20
3.2.1. Conventional Excavation.....	20
3.2.2. Drill & Blast.....	22
3.2.3. Mechanical Excavation .....	34
4. Comparison between Drill and Blast and Mechanical Excavation Methods.....	51
4.1. Mechanical Excavation vs Drill and Blast.....	51
4.1.1. Impact Hammer vs Drill and Blast .....	51
4.1.2. Vibro Ripper vs Drill and Blast .....	52
4.1.3. Road-header vs Drill and Blast .....	52
4.2. Model Tunnel Excavation.....	53
4.3. Cost Assessment.....	54
5. Analysis .....	55
5.1. Data.....	55
5.1.1. Equipment and Staff Cost Data .....	56
5.1.2. Drill and Blast.....	57
5.1.3. Mechanical Excavation .....	73
5.2. Analysis.....	78
5.2.1. Start Point Analysis.....	78
5.2.2. Section Variation Analysis .....	80
5.2.3. Length Variation Analysis .....	81
5.2.4. Monte Carlo Simulation .....	82
6. Conclusions .....	84
7. References.....	87

## 1. Introduction and Objectives

Tunnelling and underground space construction is an activity that has always gone hand in hand with human necessities. It is easy to think about tunnelling as part of the road development produced by the appearance of cars, but it is possible to find examples of tunnelling or underground space structures all along history in all those places where there has been a need of them. This need can be people transport or housing, water transport, mining or any other activities which requires the use of underground space. For the last years, tunnelling has been closely related with transport facilities and a big development on excavating technology has been achieved, both in excavation techniques and machinery and construction materials.

Tunnel construction is a difficult activity to develop but is also a difficult activity to organise, been the significance of it in some cases underestimated and therefore, cost increasing and delay over deadline date are common on civil working world. For a proper tunnel excavation management, both in mining and in civil working, right selection of excavation method is the key parameter. There are several excavation types with their own advantages and limitations and it is the engineer's job to know under what circumstances to use one or another.

Tunnelling is not only about the excavation method selection, there are some principal factors that require special attention. These are geology and geotechnics. The ground or rock conditions are a dominant element because they dictate to a great extent whether or not mechanical excavation methods can be used, they define the wear of the cutting tools and finally they influence the support requirements of the underground excavation. Because of all the above this, the analysis presented in the thesis takes into account the geology and geotechnics so as to come up with more accurate assessment on the excavation requirements and properties of each method examined.

In this document, most common excavation methods are going to be explained and analysed in detail paying particular attention to the selection criteria.

The objective of this thesis is to perform a comparative analysis between the drill and blast method and the mechanical excavation on tunnel construction either on civil works or mining. The main goal is to develop a methodology that allows the selection of the most suitable excavation method according to the characteristics of the ground as well as the tunnel design, especially in cases where the application of both methods is possible. This comparison is mainly influenced by the use of economic performance as well as by the required time to complete the tunnel excavation.

In order to analyse all aspects of the methods, this study requires the complete understanding of the excavation methods, their characteristics, applicability, limitations, cost and how all the above are influenced by ground properties and geotechnical factors. In this manner, the first part of this thesis will be focused on describing in detail all the background information needed for the cost evaluation.

Another small part of this thesis is the study and analysis of the vibro ripper method, a new mechanical excavation technology which has arisen in the last years and is gaining importance all around the world.

The information will be used to develop this thesis is taken from different places, references and case studies. Nevertheless every excavation is different with different conditions encountered, different, geology and machines so the results reached in this thesis represent a good starting point that can be used to draw conclusions. If more detailed analysis is required the methodology presented can be used, but only after having properly adjusted parameters so as to model the unique characteristics of the excavation under investigation.

## 2. Background and Literature Research

Selecting drill and blast over mechanical excavation has always been a key point in the analysis of tunnelling technology. So, before starting with the study in this thesis, it is important to know what research other authors have made previously in the field of comparing drill and blast and mechanical excavation methods. This investigation is a good starting point for the development of this thesis and a good way of gathering information.

Several studies exist about the different excavation methods or the generation of vibrations produced during excavation over nearby structures or the affectation of the rock mass. On the following pages, some of them, the most relevant for this thesis will be quoted.

A study of the selection between D&B and mechanical excavation can be found in “Bore-and-blast techniques in different types of rock: Sweden’s experience” (Nord et al., [1988](#)). In this article, several factors as geometry and length of the tunnel, geological conditions, unconfined compression strength, joint distance, rock quality or water conditions are considered. The authors fix the selection criteria over four different categories:

- Geology and rock material.
- Geometry of the tunnel.
- Site conditions
- Economic conditions of the contract.

The conclusions of the study are that in addition to the borability of the rock, and the categories defined previously, supporting requirements are needed to consider as long they are, in some cases, much more time-consuming with the use of explosives.

A comparative study between different excavation methods is “Comparative studies on the performance of a road-header, impact hammer and drilling and blasting method in the excavation of metro station tunnels in Istanbul” (Ocak et al., [2010](#)). The study empathises the importance of the performance prediction over time scheduling and tunnel excavation economy. Figure 1 shows real data of timing of the different operations of every method.

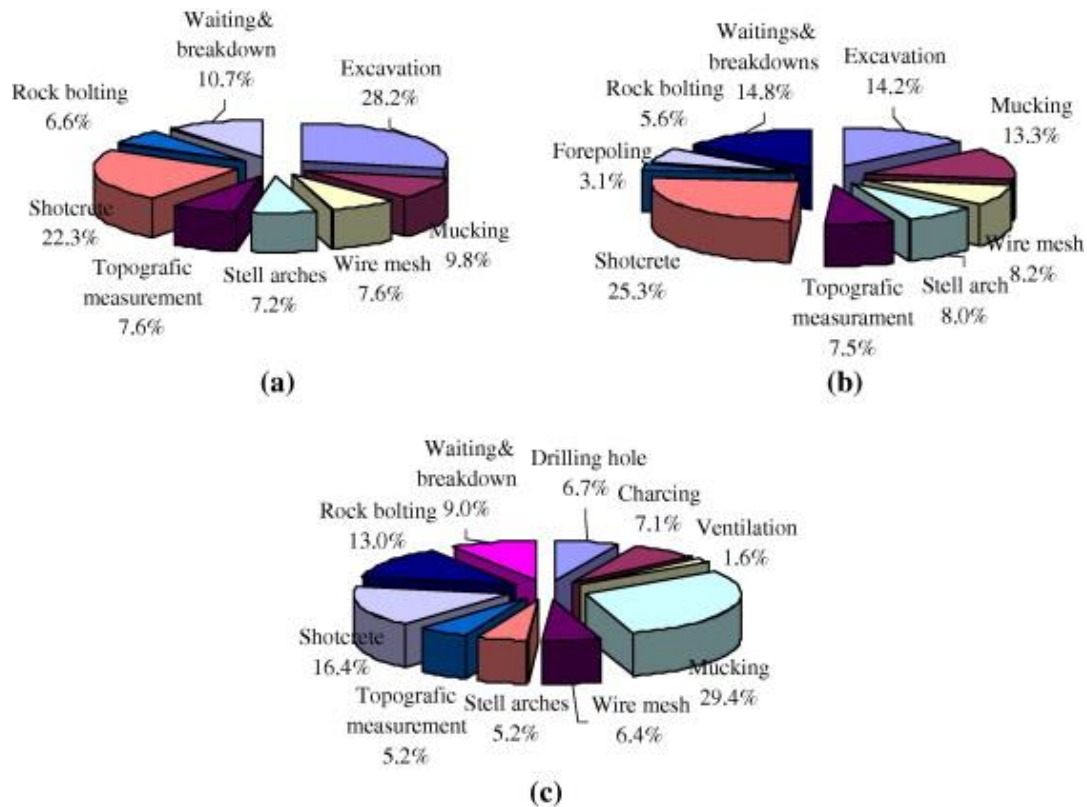

Figure 1. Timing Distribution: (a) road-header, (b) average of impact hammers and (c) D&B (Ocak et al., 2010)

This article gives the opportunity to compare three different excavation methods under similar excavation characteristics. One of the conclusions reached by the authors is that dip and joint's strikes must be considered on the predicting models.

Another interesting article about Istanbul metro is "Performance prediction of impact hammer using ensemble machine learning techniques" (Ocak et al., 2018). When the most suitable excavation method is about to be selected is important to know the advantages and limitations every one of them provide. On the article, impact hammers are studied as an alternative to drill and blast excavation. According to the authors, selection of the method should be based on factors as advancing rate, costs, set up time, feasibility and the ability to overcome geological conditions. A large number of parameters are defined as factors affecting the excavation performance. These parameters are intact rock properties, excavability of the rock mass (UCS, abrasivity, etc), rock mass properties (joints, fractures, etc), machine parameters, cutting tools, operator skills among some others.

Talking about impact hammers there is a lot of information about their use on the Istanbul metro tunnels excavation on the articles "Impact hammer applications in Istanbul metro tunnels" (Tunçdemir, 2008) and "The performance of impact hammers from Schmidt hammer rebound values in Istanbul tunnel drivages" (Bilgin et al., 2002). This information will be used as part of the data for the cost analysis. On this articles we can find information as the graph below.

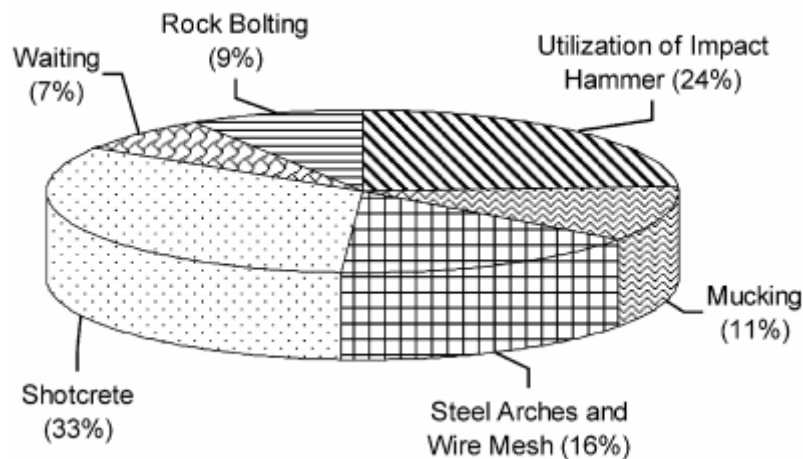

Figure 2.. Timing Distribution of Tunnel Drivages in Metro Tunnels Phase 1. (Levent Line-2, Upper Section)

Data showed in this graph is significantly different from the one in Figure 1 (b). This shows how different the excavation can be according with the geological conditions.

One of the most complete comparisons is found on the article “Mechanical Excavation and Drilling and Blasting – A Comparison Using Discrete Event Simulation” (Skawina et al., 2014). This article focus on the study on the advance rate and it is a comparison between drill and blast and mechanical excavation through a modular mobile mining machine (Figure 3). Regarding the study and only considering the advance rate, the modular machine is more interesting than drill and blast methods. This is because the work with the modular machine is more mechanised and there is a better utilisation of the time. The conclusion to take from this article is that more mechanisation entails better performances and therefore better advance rate. From the study is possible to take the timing of the processes, but there are reasons to think the values are not trustable as long as the timing of the drill and blast cycle is extremely large. Anyway the conclusions of the study are applicable in very excavation, more mechanisation entails bigger performances.



Figure 3. Modular Mobile Machine (Atlas Copco)

Comparison between drill and blast and TBM can be found on the article “Criteria for the selection of construction method at the Ovit mountain tunnel (Turkey)” (Ozcelik, 2016). In this case, although the length of the tunnel is largest than 14 km drill and blast is considered the most suitable method. The authors reach the conclusion that if there are not external factors limiting the use of one or another method (vibration limitation, geometry, etc) the selection must be made only by taking into account economic criteria.

During excavation, one of the most important parameters needed to be controlled is the disturbance over the rock mass on the surroundings of the excavation. That is not the objective of this thesis but is important to know the differences between the damage produced using explosives and the one produced by mechanical excavation. It is also important on the final cost of the excavation. The use of explosives produces over-excavation, this means the excavated section is bigger than the required one, so bigger amount of concrete is needed. A study about this affectation can be found on the article "Blast induced rock mass damage around tunnels" (Verma et al., 2018). Some graphical representation of the damage is shown in Figure 4. Other studies about affectation over the rock mass can be found on "Analysis model for the excavation damage zone in surrounding rock mass of circular tunnel" (Haiqing et al, 2013)

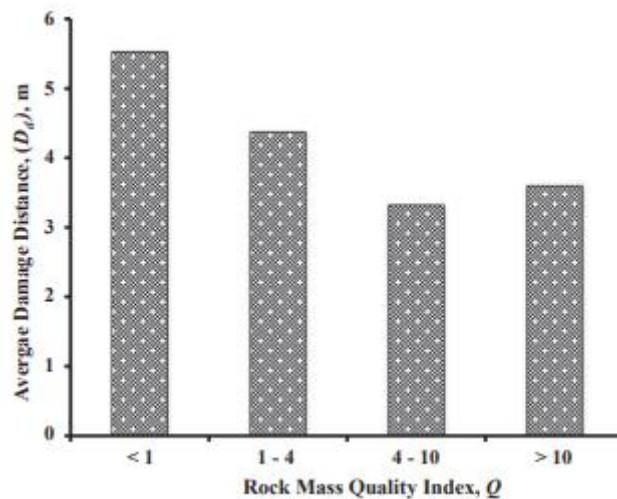

Figure 4. Variation of Damage Distance ( $D_d$ ) with Rock Mass Quality Index (Verma et al., 2018)

The information provided by the study indicates the affectation caused by the use of explosives is bigger on rock masses with poor geotechnical properties. For rock masses with better properties average damage distance remains uniform.

Rock mass affectation is even more important on the construction of nuclear waste repositories. In this aspect, several studies have been done about the excavation methods and its affectation to the rock mass. The use of explosives on this kind of excavation is discouraged because its affectation over the surrounding rock mass. This is discussed on the article "Predicting excavation damage zone depths in brittle rocks" (Perras, et al., 2016) where a numerical method is employed for depth damage predictions.

Another very important parameter needed to study are the vibrations produced during the excavation. As it's known, vibrations can produce affectation over nearby structures so they must be properly controlled. The use of explosives produces higher vibration than mechanical excavation and that's one of the main reasons explosives are not used on urban areas. There are some studies about damages produced in surface buildings, and its



importance is perfectly explained on “The use of vibration monitoring to record the blasting works impact on buildings surrounding open-pit mines” (Soltys et al., [2018](#)). The article is focus on open pit-mines but its importance is the same for underground excavation. Some interesting research is on “Evaluation of Rock Vibration Generated in Blasting Excavation of Deep-buried Tunnels” (Yang et al., [2018](#)) which is a very complete study about the effect of vibrations after blasting on deep tunnels. It is found out that vibration produced by stress release beyond about 50 meters of the blasting point is bigger than vibrations produced by the blasting itself.

### 3. Excavation

Underground excavation is an essential engineering task to facilitate the need to the utilisation of the subsurface and the creation of underground space of various needs. There are numerous examples for the different uses the underground space had during history. We can see it, for household needs in Cappadocia with the underground city located there, for water transport in some Roman tunnels or in mining on the case of Nazlet Safaha (Peer et al., [2002](#)), one of the most ancient mines. Since the ancient times, the excavation techniques have changed and the technology has appeared to improve the excavation methods.

Nowadays tunnels structures are mostly used to:

- Road and Rail Transport
- Water conveyance
- Mining
- Communication and Utilities

Underground space utilization has been focused for a long time on the development of transport infrastructure as metros or road tunnels, but the possibilities of underground space go much further than this. The development of the modern cities involves the demands of underground solutions for surface problems. The better comprehension of rock mechanics, excavation and support techniques will allow the construction of more complex project even in areas where such type of construction was not considered an option (Kaliampakos et al., [2008](#)).

Another use of underground space is on mining, when the mineral vein is located at a high depth, or when the deposit has been mined with outdoors mining and the stripping ratio ( $m^3/ton$ ) is very high, indoors mining is the only economic way to exploit the deposit.

#### 3.1. Excavation Parameters

When it is time to plan an underground construction is necessary to have some data that will allow the engineers to decide the excavation method, the type of support needed and a bunch of some other factors. The two most important parameters needed to know and for the kind of research this thesis is, are going to be excavability and drillability.

Before to start talking about the excavation parameters is necessary to dive a little inside the geotechnics. It is important to have knowledge about the rock mass is been excavated, and one of the easiest ways to do it is through the geomechanical classification. There are mainly two methods, Bieniawski's RMR and Barton's Q, being the Barton classification the most used in tunnelling.

Barton's index is calculated through 6 different parameters in the following equation (Barton, [1988](#)):

$$Q = \left(\frac{RQD}{J_n}\right) \cdot \left(\frac{J_r}{J_a}\right) \cdot \left(\frac{J_w}{SRF}\right)$$

Let's explain the meaning of every term in the equation.

RQD = Rock Quality Designation. It is defined as the length in percent of measured length of the unweathered drill core bits longer than 10 cm (Deere, [1963](#)).

$J_n$  = joint set number

$J_r$  = joint roughness number (of least favourable discontinuity of joint set)

$J_a$  = joint alteration number (of least favourable discontinuity or joint set)

$J_w$  = joint water reduction factor

SRF = stress reduction factor

This is the meaning of every term, but the ratios have a different meaning as it's going to be explained.

$\left(\frac{RQD}{J_n}\right)$  = rock blocks size. As long the RQD is measured in cm it will be measured in centimetres.

$\left(\frac{J_r}{J_a}\right)$  = shear strength between the blocks

$\left(\frac{J_w}{SRF}\right)$  = influence of the tensional state

According to Barton classification, the quality of the ground will be classified from exceptionally bad to exceptionally good as it is shown in Table 1.

Table 1. Barton's Q Values (Barton, 1988)

Q (Barton)		Quality
0	0,01	Exceptionally Bad
0,01	0,1	Extremely Bad
0,1	1	Very Bad
1	4	Bad
4	10	Medium
10	40	Good
40	100	Very Good
100	400	Extremely Good
400	1.000	Exceptionally Good

### 3.1.1. Excavability

Of all the excavation parameters, excavability is the most important one. It describes the influence of different parameters over the excavation and it is a measurement of how difficult it is to remove materials from the ground. Excavability is described as a function of the geotechnical characteristics of the rock mass or, in another words, it evaluates the possibility of the mechanical excavation of the ground.

Excavability is comprised by different parameters of the materials that constitutes the rock mass where abrasivity, compressive strength (UCS), toughness and tock mass structure are the most important ones. The study and comprehension of all of these parameters is going to allow the engineers to understand to a greater extend the behaviour of the rock mass before the beginning of the excavation and use that knowledge to select the most suitable excavation method.

### Uniaxial Compressive Strength (UCS)

Uniaxial or Unconfined Compressive Strength is a measurement of how strength the rock is. This kind of test provides a chart like the one on Figure 5 where the behaviour of the material can be studied.

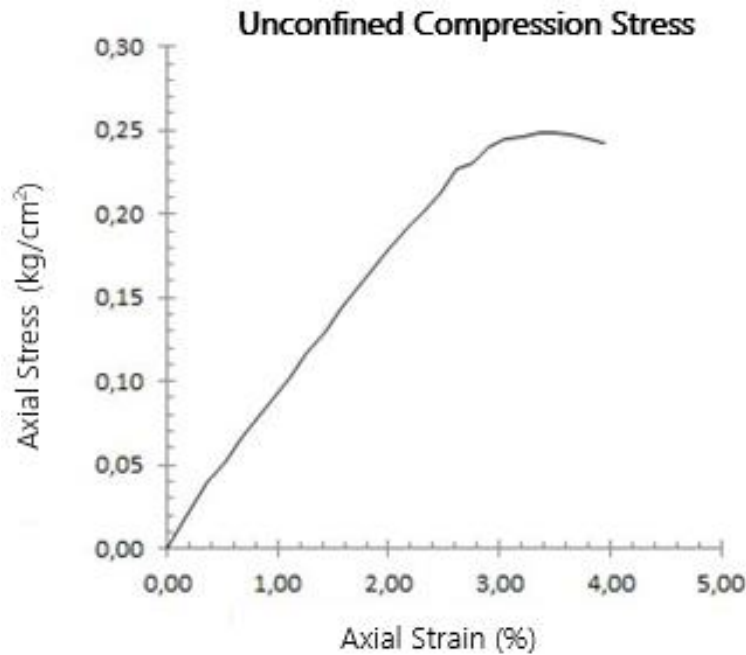

Figure 5. Unconfined Compression Strength

The test takes place mainly to measure the uniaxial compressive strength of a rock sample, but also for determining stress-strain curves, Young modulus and Poisson's ratio (ISRM).

UCS is the maximum uniaxial compressive stress that a test sample can withstand under unconfined conditions and it is represented by the maximum value on the previous graph. The amount of stress needed to break the rock is defined by this parameter.

Young's Modulus defines the relationship between stress and strain of a material and it is defined as the UCS test curve.

Poisson Ratio is an elastic constant which represents the width variation of the section of a sample material as long this is linear and isotropic when it is submitted to the compressive forces.

It is important to emphasize that higher is the UCS of the rock, bigger is the energy needed to break it. This means that for higher UCS values more powerful equipment is needed for excavate it.

There is another method to obtain the UCS of the rock mass in situ instead through laboratory tests and it is using the Schmidt hammer. The hammer works measuring the number of rebounds of a spring-loaded mass when it impacts against a surface, in this case the excavation face of the tunnel for example, with a defined energy. Schmidt hammer must be used several times on the same surface, and the rebounds value will be the mean of all the measurements despising the highest and lowest value to avoid measurement errors. Once the number of rebounds is known, and knowing the density of the rock is possible to enter the graph of Figure 6 and obtain the UCS of the rock mass.

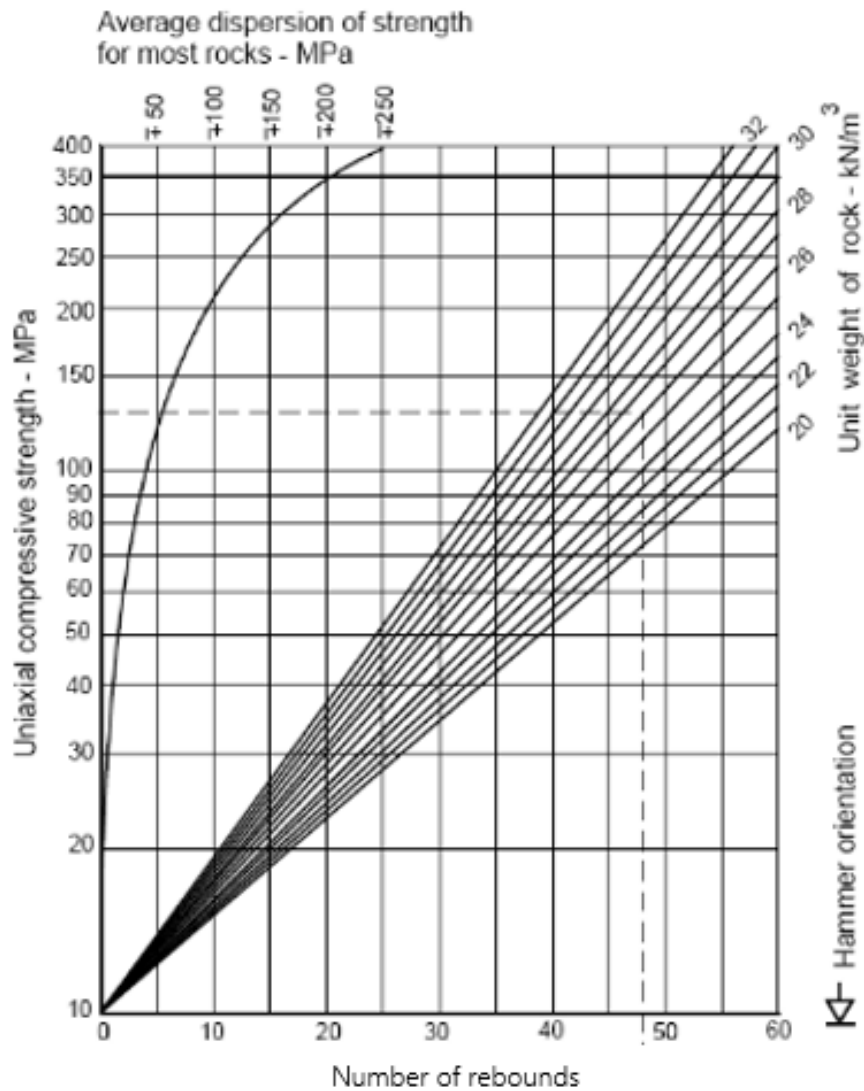

Figure 6. Schmidt Hammer UCS Estimation (Miller, [1966](#))

### Abrasivity

The term abrasivity describes the potential of a rock or soil to cause wear over the excavation tools and, marginally, over the transport systems. Consequently, abrasivity is an important rock parameter to be determined and to be described in the course of any larger road, tunnel or mining project in order to allow the contractor to assesses economical aspects of excavation methods (Plinninger, [2010](#)). When talking about excavability, and mostly when talking about mechanical excavation, abrasivity is the main parameter to consider.

It is important to know what wear is and its types. Some authors (Nilsen, [2006](#)) talk about primary and secondary wear, where the primary one occurs over the excavation tools and the secondary one over the hold support structures of the excavation tools when the primary one is excessive. Highly abrasive rocks are going to entail bigger and faster wear of the excavation tools, but also important wear over the transportation rigs. This big wear

means that the excavation tools are needed to be replaced in shorter times, increasing the total cost of the excavation process.

There are different indexes to measure the abrasivity of one soil or rock mass. The most important one is the Cerchar test (CAI). This is a laboratory method for obtaining the abrasivity of the rocks (Tugraz, 2019). With this test, it is possible to build graphs and relate abrasivity with UCS as it is shown on Figure 7.

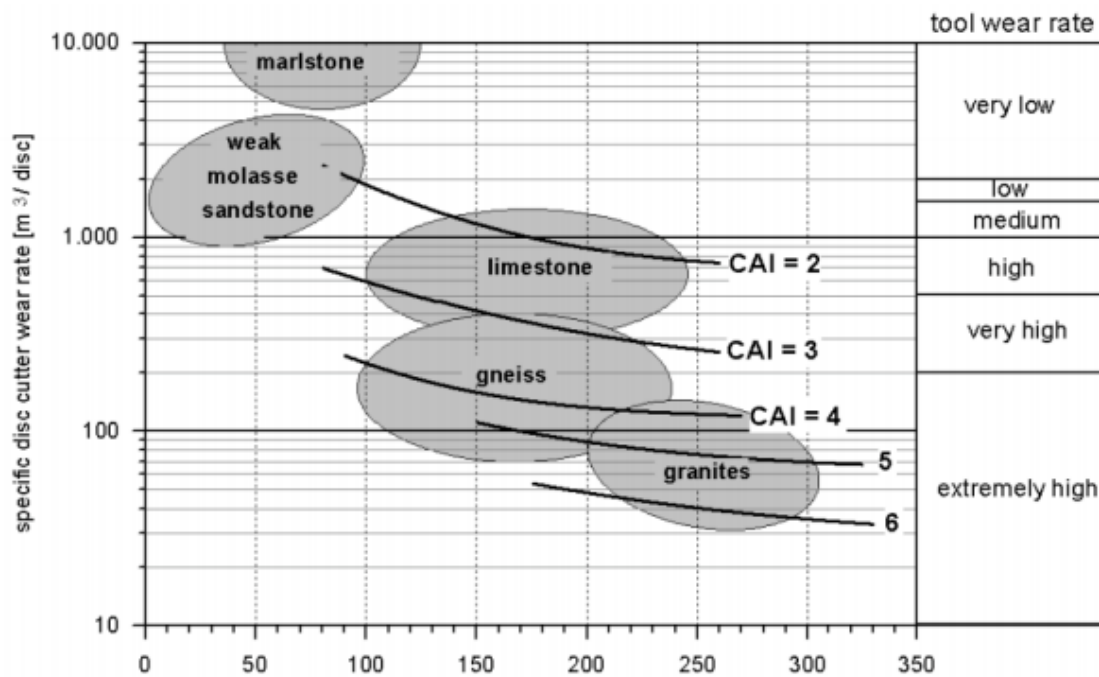

Figure 7. Correlation of TBM Cutter Life, UCS and CAI for some Common Rock Types (Maidl et al., 2001)

Studying the graph, biggest values of the Cerchar test are related with hard rocks as granites where the tool wear rate is very high while the lowest values correspond with also low UCS values and medium-low tool wear rate.

Other one of that indexes is the quartz content, which is a measurement of the amount of the relative content of quartz mineral in a rock (Akhavan, 2004). Using this index, some graphs have been made as the ones showed on Figure 8, where is possible to study the wear on the drilling picks in function of the quartz content of the soil.

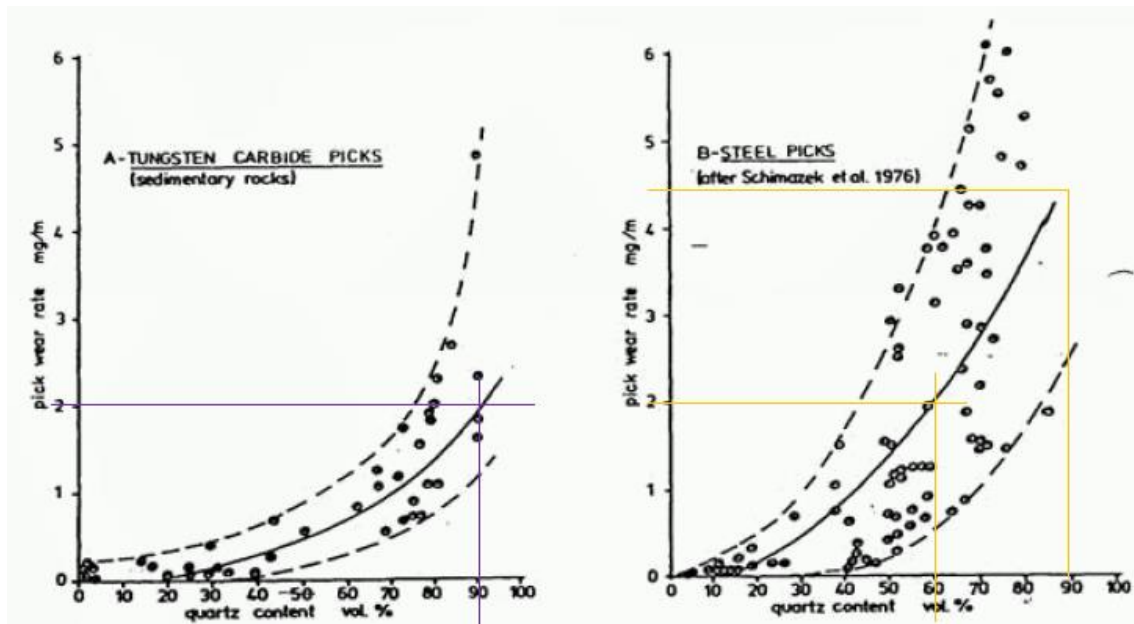

Figure 8. Pick Wear vs Quartz Content

Regarding the graph, the wear of the drilling picks increases with the quartz content as is expected. Per this, the conclusion is that in rocks with higher quartz contents, and therefore with higher wear of the drilling picks the cost is going to be bigger than in rocks with lower quartz contents due to the drilling picks will be needed to be replaced in shorter times. Also, in the graphs it is shown that for the same quartz content, tungsten carbide picks are better than steel picks because their wear is lower, as it is shown, to reach the same wear it is needed a quartz content value over the double for steel picks, but they are also more expensive. Is a task for the engineers to decide between more expensive drilling picks or cheaper ones but with shorter live span and therefore, with more stops to change them.

There are other tests to study the abrasivity of the rocks as the Schimazek coefficient but it is not going to study it in this document.

### Toughness

Toughness is described, in the world of mining, as the behaviour of the minerals when they are submitted to different type of efforts as breaking, crushing or bending. It can be also described as the total deformation energy which a material is capable to absorb or accumulate before to break and can be expressed as the area below the stress-strain curve.

There are different behaviours a rock mass can experiment, the most common ones are shown:

- Brittleness
- Elasticity
- Ductility
- Plasticity

For all these behaviours, the most important and the one who deserves to talk about it is brittleness.

### Brittleness

By the name of brittleness is known as one of the most important mechanical properties of rock masses, and it plays an important role on evaluating the risk of rock bursts, which is one of the most important risks on underground workings. It is defined as the ability of a rock to accumulate elastic energy during the pre-peak stage and to self-sustain fracture propagation in the post-peak stage (Ai et al., 2016). Brittle is a type of behaviour of some materials where there is little or no ductile deformation once the yield point was reached producing failure.

The knowledge of this parameter is important to predict damage around excavation and to design a supporting with full guaranties for the stability of the tunnel.

### Specific Energy

Another important point to talk about in this point is specific energy. For excavation of the rock a quantity of energy is needed, but the amount of energy will depend entirely on the nature of the rock (Teale, 1964). This is shown in Figure 9 where the specific energy is the energy required for ripping 1 cubic meter of rock.

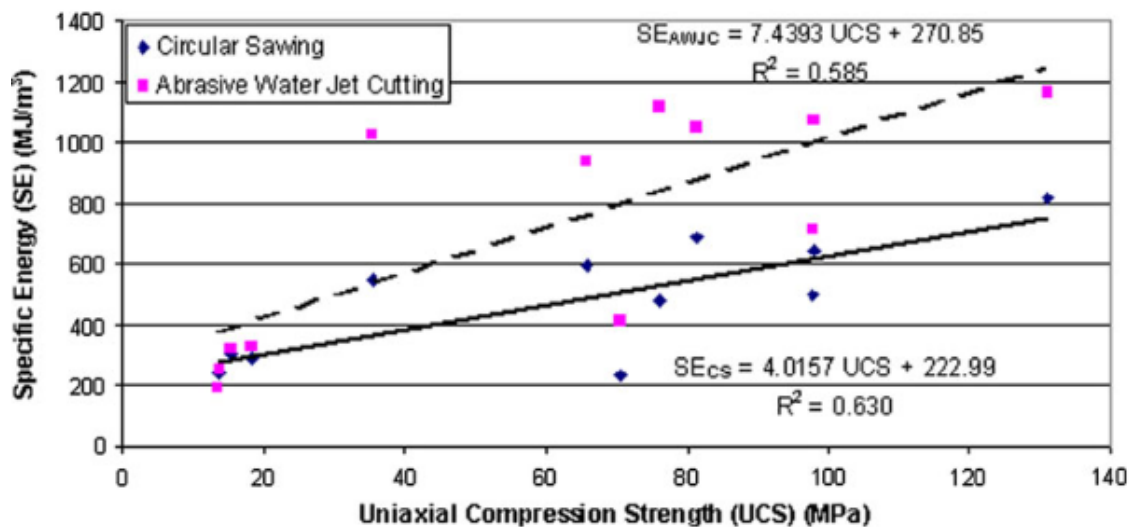

Figure 9. Specific Energy vs Compressive Strength (Engin et al., 2013)



As is possible to see on the graph, the required energy increases with the hardness of the rock, this means harder rocks are more difficult to excavate and requires more energy to do it.

The main use of this parameter is to evaluate the possibility of the use of road-headers in excavation, so it is a good indicator for the application of mechanical methods,

### Rock Mass Structure

There is a large number of parameters to consider when planning an excavation with mechanical methods. These parameters are the employed on the geomechanical classifications as the RQD, joint family number, orientation and spacing among other parameters.

The number of methods which classify the excavability of the rock mass according to the geomechanical parameters is wide, but one of the most famous is the Franklin classification. Franklin suggests to classify the rock masses considering spacing and UCS and considers 4 categories as mechanical excavation, ripping, pre-blasting and blasting. Franklin classification is shown on Figure 10.

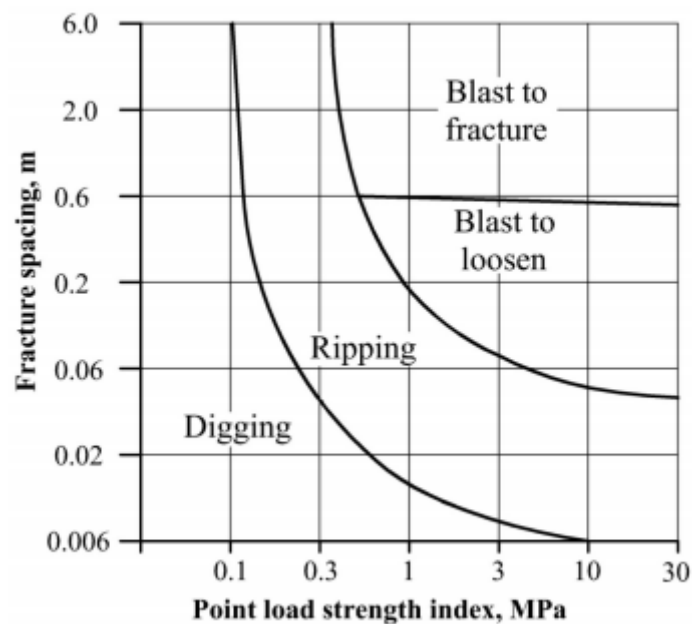

Figure 10. Franklin Method (Franklin et al., 1971)

The graph represents the fracture spacing, known as the RQD against the point load strength index, but it can also be referred to the UCS or Schmidt value, which is easier to use.

### 3.1.2. Drillability

Rock drillability is another of the most important parameters on the planning stages of an excavation project. It can be defined as the ability of the rock to be drilled or bored, and it considers the influence of properties as breakability and blastability have during drilling and boring (Macias, [2017](#)) and is a key parameter on determining drilling costs and over determining the properties of the drilling tools. There is a wide number of methodologies that can be used to define the drillability but almost all of them are related with the empirical properties of the intact rock, as uniaxial compressive strength, surface hardness of the rock or abrasivity among others and the specifications of drilling equipment (Arabi Shad et al., [2016](#)).

In the study of drillability there are two key parameters which are the most valuable ones. These parameters are the net drilling rate (in meters per minute) and the bit life span (in meters per drilling bit) in a homogenous tunnel section (Thuro et al., [2003](#)). Let's see what these parameters refer to.

- Drilling rate index (in meters per minute): it is derived from the time of drilling one single blasthole and is also known as the drilling performance. It allows the engineers to predict the drilling performance in drill and blast excavation. Figure 11 shows how to find out the drilling rate index from the brittleness test and the Sievers J-miniature drill test.

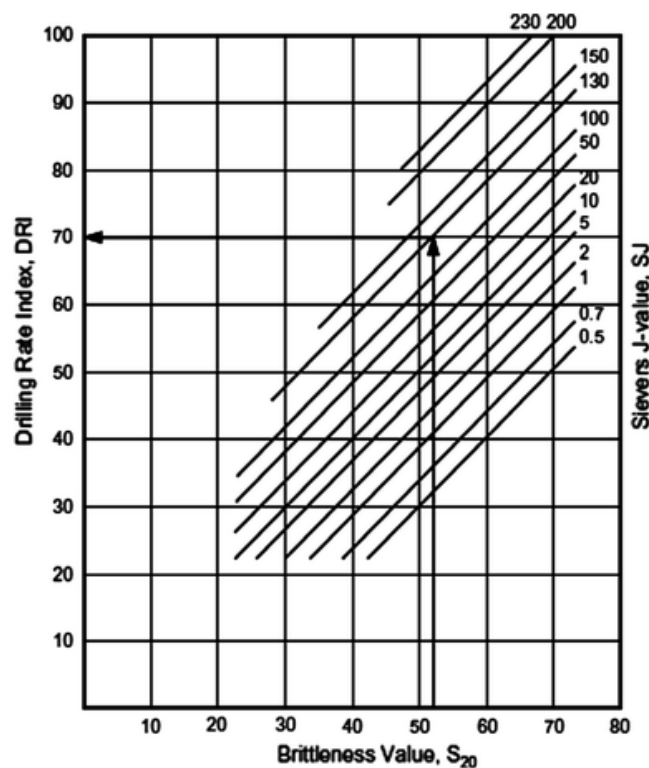

Figure 11. Drilling Rate Index (Dahl, [2003](#))

- Bit life span (in meters per drilling hour): drilling bits life span is an important parameter in the economy of the excavation, it is going to tell the engineers the perfect moment to change the drill bit, so it will allow to achieve the knowledge of the number of drilling bits that there are going to be needed and, according to that, the total cost of the drilling process.

### Breakability

Breakability is one of the intact rock properties drillability considers. Can be considered inside breakability a bunch of different properties as strength, brittleness and surface hardness properties. There are different laboratory tests to determine the breakability of the rock (Macias et al., [2017](#)) as the uniaxial compressive strength test, the Brazilian tensile strength test or the brittleness value.

### Blastability

This term is only used in the frame of drill and blast excavation and it is a measurement of the difficulty to blast rock masses under determined blasting conditions and explosive properties (Chatziangelou et al., [2019](#)).

Blastability index allows the engineer the collation of geotechnical information to a decent estimate of the in-situ characteristics of the rock mass and approximate its response to explosive energy of the blasting (Kealeboga Segetsho, [2017](#)).

There are four parameters whose importance on blasting performance is significant, these parameters are Structural Nature (RMD), Joint Plane Spacing (JPS), Joint Plane Orientation (JPO) and Specific Gravity (SGI) and Hardness (H) according with Lilly (Lilly, [1986](#)) the blasting index can be calculated as:

$$BI = 0,5 \cdot (RMD + JPS + JPO + SGI + H)$$

Low values of blastability index indicate difficulty for blasting and high values indicate easy rocks to blast.

Another interesting parameter to know is the powder factor. Is known under this name the relationship between how much rock is broken and the amount of explosive that is needed to break that amount of rock. It is calculated as:

$$\text{Powder Factor} = \frac{\text{Rock Blasted}}{\text{Amount of Explosive}}$$

## 3.2. Types of Excavation

When engineers must face the excavation, there are several excavation methods they can choose, and the selection of the most suitable one is going to be based only in economic and temporal criteria. At this point, only most used methods and the differences between them will be described.

The most employed types of excavation are:

- Conventional Excavation
- Drill & Blast
- Mechanical Excavation

Inside every group is possible to find different excavation methods as is going to be explained in the following lines.

### 3.2.1. Conventional Excavation

#### 3.2.1.1. *Traditional Method*

Traditional methods consist on the excavation of the ground through the use of manual or mechanical methods but without or with very low mechanisation. When talking about traditional method is possible to talk about traditional method in rocks or traditional method in grounds. The traditional method in rocks is based in the use of explosives, but in this document its use is going to be considered apart as long as they are one of the central points of this study.

Into the traditional method, the degree of mechanisation of the ground is going to be a variable dependent on two parameters as:

- Dimensions of the Gallery: if the dimensions of the gallery allows the use of excavation rig, the mechanisation of the works is going to be bigger as so the production and, as consequence, the cost per cubic meter lower.
- Geotechnical Characteristics of the Country Rock: this parameter is going to define the need of supporting of the gallery. On rock masses with very poor bearing capacities, basically soils or very fractured rocks, the advance entail big support problems, so it must be small. That is a problem for the use of heavy equipment, because big machines do not allow little advances.

Between these two parameters, the geotechnical conditions is going to be the constraining factor.

Traditional method is not one only method, is a general name for a methodology which consists on divide the full gallery in small sections and sequence the advance to keep the stability of the whole tunnel. In Figure 12 can see a sketch of the Belgium Method, one of the different methodologies inside the traditional method.

As seen in the figure, this method consists on attacking at first place the crown of the gallery, then the drift walls and finally the rest of the tunnel.



Figure 12. Belgium Method



Figure 13. Austrian Method

There are other different methodologies as the Austrian Method, which is shown in Figure 13. In this method the drift walls are the last part to attack. Multiple different methodologies can be found, and the use of one or another depends on the confidence of the engineer on the method and in the characteristics of the ground.

Is important to say, that both drift walls cannot be attacked at the same time. The excavation of drift walls is the critical part of the traditional method and

it is one of the most dangerous moments, because it can induce the collapse of the excavated structure.

Other methods execute the excavation of the drift walls at first place to protect the crown. Basically, the order of excavation works is sequenced in function of the characteristics of the country rock and always with the priority to guarantee safety conditions on the excavation.

When the engineers are facing grounds, where the characteristics are unfavourable, there is impossible the use of machines in some stages of the working, this force to the use of manual methods. Figure 14 is an example of this. Is possible to see how in the crown of the gallery there is a new phase of the excavation whose size is smaller than one person, this is because the support necessities of the ground are significant. For this reason, the use of machinery is impossible.



Figure 14 Excavation of a Gallery with Manual Methods (Professor García Menéndez, 2018)

When the conditions of the excavation allow the use of some kind of excavation rig, the production and the economics of the working are going to be more productive. This method consists on the use of excavator to attack directly the ground from the face of the excavation. Instead of manual excavation is going to be mechanical excavation so the performance is bigger than the manual methods. For this to be possible, the ground must be diggable or at least rippable. This show the importance of previous studies as was discussed previously explaining the Franklin classification (Figure 10).

### Pros, Cons and Limitations

The use of traditional method is relegated to when no other method can be employed, this means that the use of this method presents some drawbacks. These are

- Poor production performances even when in some few cases with particular conditions these methods mechanised with excavators can face road-headers in performance (Professor García Menéndez, 2018)
- Very specialized staff is needed even for excavating and planning.
- Dangerous workings. The risk of the crown to fall is big.

### 3.2.2. Drill & Blast

Drill and blast methods consists on the use of explosives to break the rock of the face of the tunnel. The break mechanism is produced due to the high gas pressures generated during the detonation of the explosive. When the explosive releases its energy, it generates a high-pressure shockwave (from 1 to 30 GPa) which is propagated at speeds in the order

of magnitude of the sound. The propagation of the high pressures on a compressed blasthole causes the break of the rock.

Nowadays, the use of explosives in tunnelling is one of the most common methods of excavation and it is improved in which is known as the New Austrian Modified Method (NATM). This is a methodology which reduces the necessity of support allowing the rock mass to deform within some reasonable limits. For this is necessary the use of passive support, special rockbolts which start acting after a significant amount of deformation of the rock mass calculated previously.

Drill and blast is a whole methodology composed for different processes, and the objective of the excavation for this method is to achieve the lowest cost in the whole process and not on the blasting. Figure 15 shows the objective between the cost of every part of the process and the result of the blasting or the degree of fragmentation.

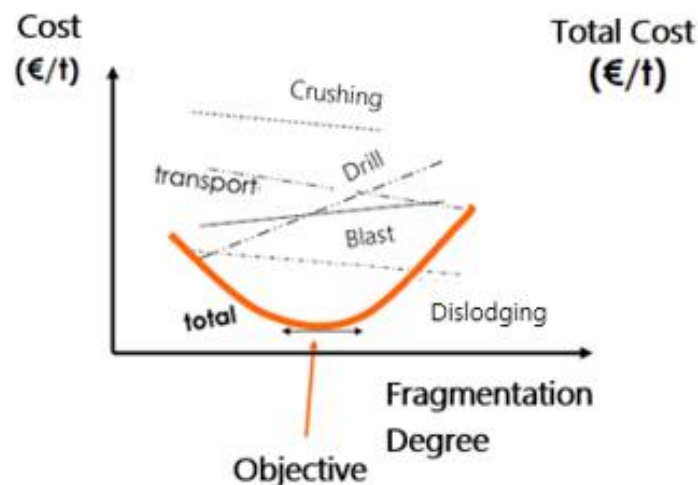

Figure 15. Drill and Blast Objective (Professor Martínez Torres, [2018](#))

When talking about drill and blast on tunnelling there are some considerations that there are needed to make.

- It must be created a relief, perpendicular to the face of the tunnel (free face) with the blast of the first blastholes with the objective to create a second free face to ease the fragmentation and the movement of the blasted rock.
- The blastholes must be overload on explosive to compensate confinement of the rock.
- As result of confinement and the lack of free faces, the delay between blastholes must be bigger than in an outdoor blasting to allow the movement of the rock of the previous blastholes.
- Blastholes at the perimeter of the excavation must have an angle to outside to keep the section of the tunnel constant. This is called the angle of adjust.

- The burden of the blasting is calculated at the bottom of the drills, considering the angle of adjust.

### 1. Production cycle.

For the correct understanding of this method, it is necessary to define the whole production cycle of it. It will also be important because the costs of every small part are important to be known to develop the following study. The production cycle has been defined in Figure 16.

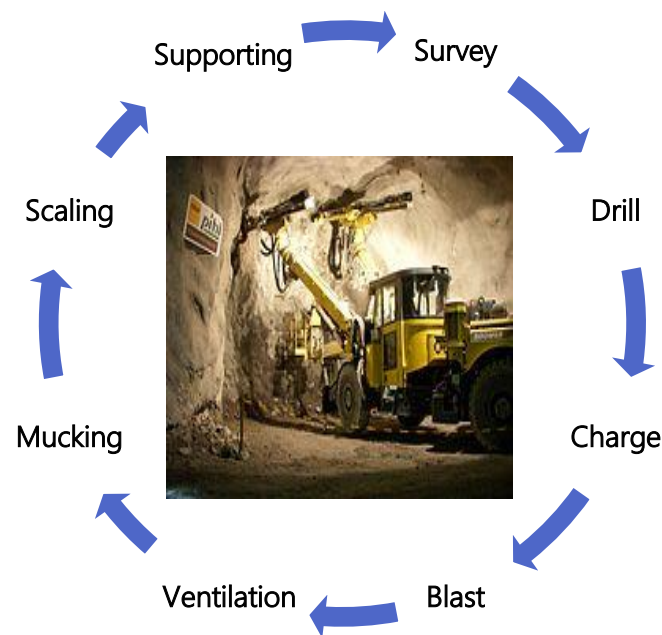

Figure 16. Drill & Blast Production Cycle

Once the production cycle is defined it is time to explain every one of the operations which takes part on it.

#### Survey

On underground excavation and specially on the frame of the New Austrian Modified Method (NATM), the study of the face of excavation at the beginning of every production cycle is needed. NATM support is calculated through geotechnical classification, most commonly Barton's Q system, and the characteristics of the country rock can change during excavation. Because of this a geologist is needed to examine the tunnel face at the beginning of every production cycle.

In blasting, survey is very important for:



- Checking the changes on the geology and modify the blasting design according to it.
- Analyse the result of the previous blasting and measures the advance of the pass.
- Check it is safe to drill on the face of the tunnel.
- Set the correct direction of the advance according to the project considerations

## Drill

Drilling is the critical part of the drill and blast method. A proper drilling produces a controlled blast and reduces costs, but problems on drilling can produce the increase of the cost of blasting (more explosive needed) or even catastrophic fails in blasting.

Nowadays, drilling on underground excavations is performed by special machines called jumbos. These jumbos are hydraulic rigs constituted for 1 to 3 booms which can be employed on manual, semi-automatic or automatic drilling.

The figure of the drill runner is one of the most important ones in the whole excavation because he is the one who can notice the changes on the geology of the rock mass behind the face of excavation and can also notice drilling failure during the process. Drilling failure can make the whole blasting to fail.

## Drilling Failure

They exist different drilling failures which can make fail the whole blasting, some of them are going to be discussed now.

Figure 17 represent the failure on the parallelism of the blastholes. Because of this problem, the burden at the bottom of the drill is going to be bigger than the calculated and, because of that, the amount of needed explosive is bigger. The result of a blasting with this fail will be very poor fragmentation of the rock.

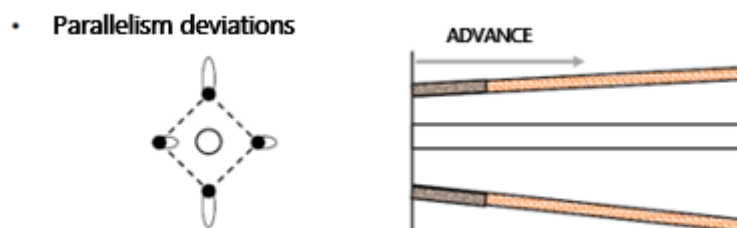

Figure 17. Parallelism Deviations

Figure 18 is an example of a small expansion blasthole. In tunnel blasting, the cut is the part of the blasting responsible of opening a new free face, it is achieved through expansion blastholes with bigger diameter than the blast blastholes. In this case is not going to be

generated a new free face, so the result of the blasting will be poor fragmentation and no displacement of the blasted material.

- **Small diameter on the expansion borehole**

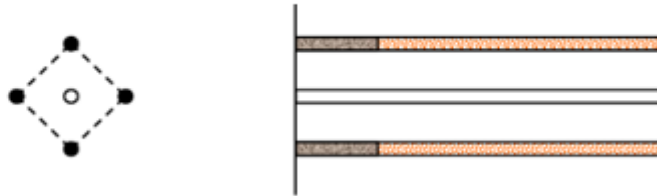

Figure 18. Small Expansion Drill Diameter

Figure 19 represents another common perforation problem, which is variations on the length of the drill. Expansion blasthole are drilled to create the free face for the blasting to go out, any drill length over the length of the expansion blasthole is a waste of explosive. This happens because the house rock is submitted to big containment. It can be interesting the expansion blasthole to be from 15 to 30 cm longer than the blasting blastholes to increase the blasting advance.

- **Blasthole length variation**

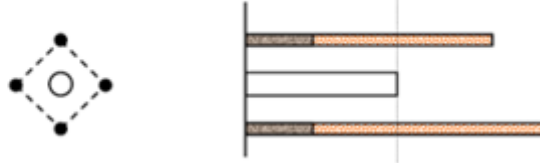

Figure 19. Length Drill Variation

Another important failure is irregular spacing as shown in Figure 20. This means the burden between the drills is going to be different so the necessity of explosives in every drill will be different and, as consequence, the blasting result is not going to be the expected.

- **Irregular drill spacing**



Figure 20. Irregular Drill Spacing

## Charge

Once the blastholes are drilled is necessary to fill them with the explosive and make the connections with the proper detonators for the correct result of the blasting. About the type of explosives, detonators and timing of the blasting will be talked about further on this document.

On the charge of the explosive is necessary to differentiate between the use of cartridges or the use of liquid explosives. For the use of liquid explosives is necessary to prepare a primer or even a booster at the bottom of the blasthole as long the detonator is not electric. Electric detonators are usually employed at the top of the blasthole.

For the use of cartridge of explosive are different ways to prepare the blasting. One way is to introduce one or two cartridges, stemming, and repeat the process until the blasthole is prepared. Another way to do it is to tie the cartridges to a long wood stick with the use of tape or similar and introduce the wooden stick on the blasthole and at the end stemming. Of course, when preparing the blasting the primer is placed at the bottom of the blasthole.

When all the blastholes are filled with explosives, it is necessary to assign times to every blasthole. Detonators have a retard time, but the retard can also be given on the tunnel face.

## Blasting

Once the blastholes are prepared it is necessary to start the blasting. If the detonators used are NONEL type, they are started with an electric detonator attached to the NONEL main tube. In case of using electric or electronic detonators is only needed to connect them to the blasting machine and start the blasting.

## Ventilation

After the blasting, blasting gases (CO, NO, and NO<sub>2</sub>) and dust are produced. To continue with the production cycle is necessary to dissipate that gases and dust. Tunnelling present the problem the excavation is at end of line so it is necessary a ventilation system to remove the gases and the dust.

They exist 3 different types of ventilation, blowing, exhausting and mixed. The differences between them won't be explained, just to tell that for TBM it's usually employed exhausting and for the rest of methods blowing.

## Mucking

Once the tunnel is ventilated is time to muck the blasted material from the face of the tunnel. The material is charged into tracks by excavators (backhoe, crawlers, loaders...) or carried directly out of the tunnel by a LHD loader, selected according to the dimensions of the gallery and the expected production.

On the selection of the number of transport units (LHD, tracks, dumpers or continuous transportation systems) is necessary to consider that as the tunnel advances the transportation distance increases and the time of this part of the production cycle is going to be increased.

### Scaling

When excavating a tunnel, its final geometry is defined by the project requirements. In this point engineers can face two problems:

- The excavated section is smaller than the requirements of the project, this is called under-excavation
- The excavated section is bigger than the project requirements, this is called over-excavation.

From these two problems, under-excavation is preferred. During scaling the final section can be achieved but with lower production performances using hydraulic hammer or other mechanical methods. If over-excavation is produced the only solution is the use of concrete to fill the gap, and concrete is expensive, being able to increase the cost of the project in a large extent.

### Supporting

Supporting is the most important part on tunnel excavation. One famous sentence in tunnelling world says that is easy to excavate a tunnel, but is difficult to support the excavated rock mass. Drill and blast method produces big affectation on the rock mass, so supporting must be carefully designed to guarantee tunnel stability. Supporting design is not a part of this thesis but is important to know some things about it to calculate the timing and the total cost of the production cycle.

There are three basic types of supporting:

- Shotcrete: consists on the application of projected concrete over the tunnel walls to obtain an immediate support.
- Rockbolts: are used to sew the joints and its use transfers the loads from the face to the interior of the rock mass.
- Steel sets: are used when the ground geotechnical properties are really low. It consists on a steel structure built to support the rock mass.

## *II. Blasting Design*

Once the production cycle is known, it is time to design the blasting. Tunnel blasting is more complicated than outdoors blasting due to the only existence of one free face and the high degree of containment the rock mass is submitted to. It is necessary to create another free face to allow the blasting the possibility of move the rock and achieve good fragmentation and advance.

The creation of this new free face is made through the cut. Define what is a cut, its importance and explain the different types of cuts it exists. The contour of the blasting is also important as the section must be maintained unvarying all along the tunnel length.

There are two methodologies inside tunnel blasting depending on the section of the tunnel which are whole section blasting or heading and bench blasting. It is preferred to blast the tunnel in whole section but in some cases, when the section is big, is needed to advance a small part of the section with tunnelling blasting techniques and the rest of the section with outdoor mining techniques having better performances.

As it's shown on Figure 21 the blasting is divided in different parts as cut, contra-cut, blast and contour.

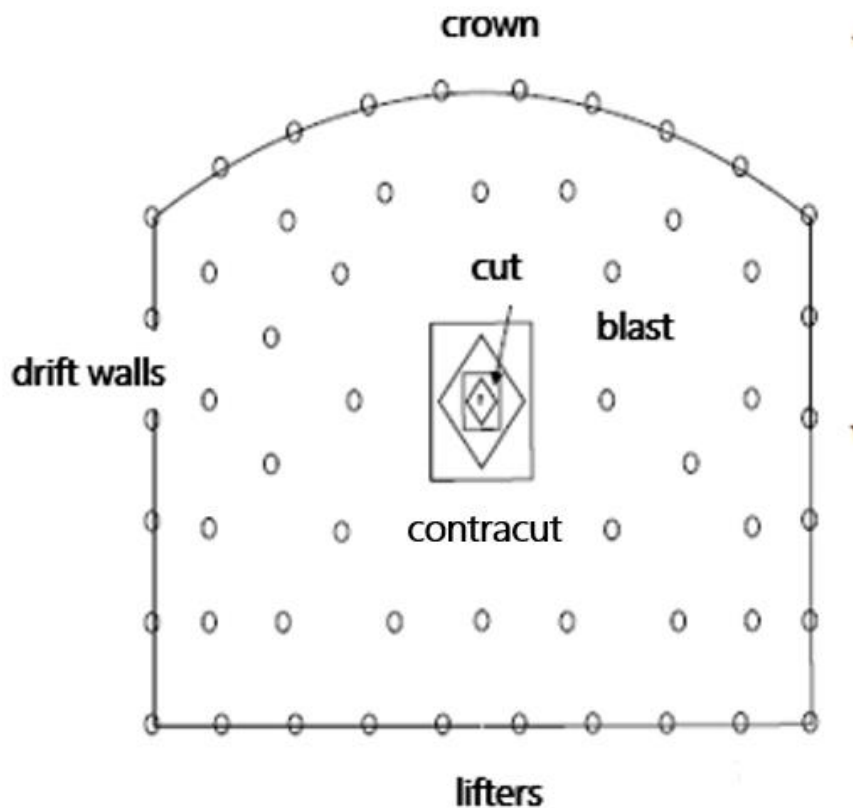

Figure 21. Parts of a Tunnel Blast

The methodology to calculate every part of the blasting is different, so cut and contra-cut, blast and contours (lifters and drift walls and crown) are going to be calculated separately.

### Blasting Patterns - Cuts

On the designing of the blasting, important attention must be paid on the design of the cut. Its importance is as big as to say that the blasting is going to advance as much the cut advances. Blastholes can be drilled in angle or in parallel, and every drilling scheme is divided in different type of blasting patterns (cuts).

- Angle Drilled Blastholes: nowadays are almost unemployed because the drilling operation is very delicate to obtain the desired burden at the bottom of the blasthole, and its length is limited by the gallery dimensions. Inside this methodology there are two different cuts.
  - Fan cut
  - V cut
  
- Parallel Drilled Blastholes: it is the most employed nowadays due to it is easier to drill than the angle drilled blastholes. The different type of parallel blastholes are:
  - Crater cut
  - Burnt cut
  - Cylindrical cut

Of all the possible cut design, the most employed are the cuts with parallel blastholes and, above all the others, the cylindric cuts because they provide the biggest advances. This type of cuts employees empty blastholes with a bigger diameter than the rest with the function of acting as a free face. This relief generated by the cylindric cut, reduces the number of blastholes needed. As it is shown on Figure 22, the excavation advance increases with the increase on the diameter of the expansion blasthole.

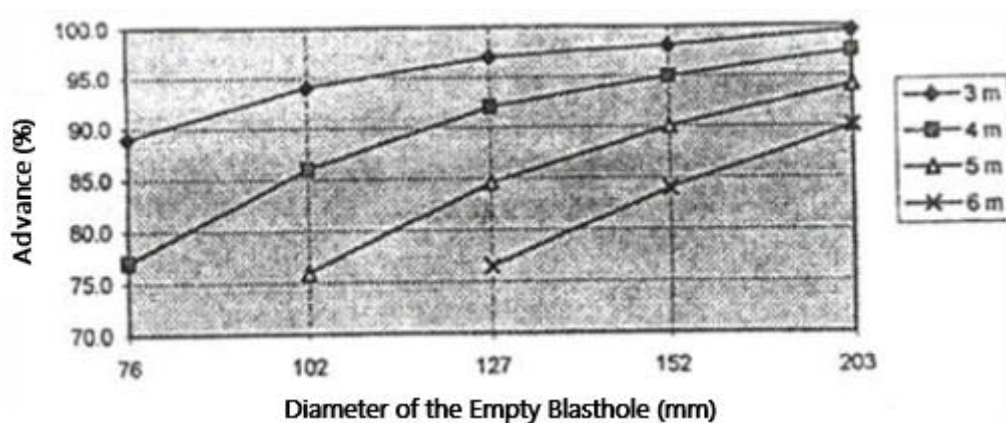

Figure 22. Advance in Function of Empty Blasthole Diameter (Professor Martínez Torres, [2018](#))

The design of the cut can get different geometries and it will depend on the experience of the engineer who is designing the blasting and on the characteristics of the rock mass to choose one or another. Some of that geometries will be shown in the following lines.

Figure 23 shows a four sections cut. This design has two secant expansion blastholes in the middle while the remaining blastholes are going to be charged with explosive. The numbers over the cut are the detonating times so is possible to follow how the opening of the free face is going to be.

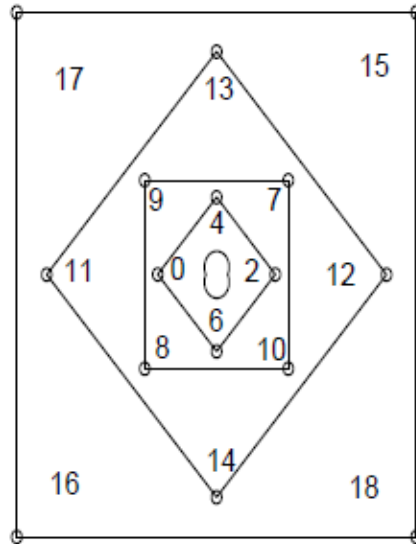

Figure 23. Four Sections Cut

They exist other designs as the Fägersta (left) or Coromant (right) cut showed on Figure 24 among other different designs.

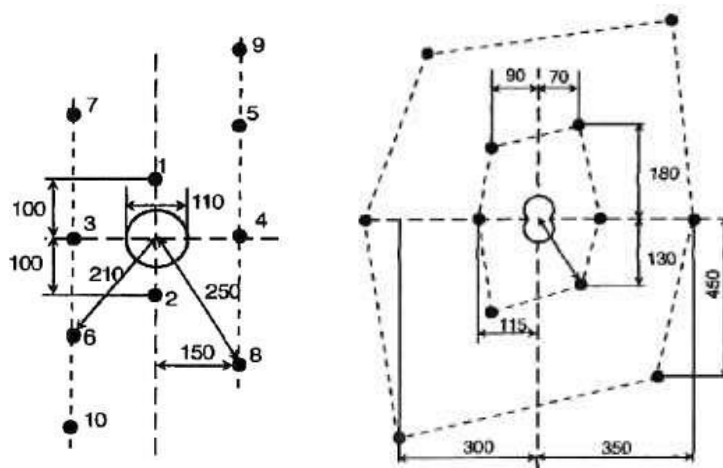

Figure 24. Fägersta (Left) and Coromant (Right) cuts

The preferred position for the cut is symmetric to have fewer number of blastholes and in the high part of the tunnel in order to achieve the maximum displacement and the best

fragmentation of the rock. Anyway, the position of the cut needs to be rotated because is necessary to avoid drilling over the blastholes of the previous blasting for security reasons.

### Blast

Once the free face is created the main part of the section needs to be blasted. This process depends in high degree of the result of the cut and is the biggest part of the blasting.

### Lifters

This is the part of the blasting located at the bottom of the tunnel. They are calculated with contour blasting techniques, this means the spacing between the blastholes is lower than in the main blasting and uncoupled explosive. It can also exist an attenuated line previous to the lifters to protect the rock mass.

It is important to blast the lifters with an angle through outside the tunnel to keep the section constant and to obtain the desired slope.

### Contour or Perimeter Blasting

Contour is composed by the drift walls and the crown of the tunnel, but also the lifters are designed with contour techniques (lower spacing and uncoupled explosive). The blastholes must be drilled with an angle through outside the tunnel to maintain the section of the gallery. Contour is the last part of the blasting which takes place and in most of cases the blasthole line closest to the contour blasting is attenuated to protect the rock mass.

### Explosive Selection

Explosive selection is one important step on the designing of the blasting. From the characteristics of the explosive, blasting parameters as the burden will be calculated. There are several explosive manufacturer companies as Orica, Maxam or Extraco, all of them produce similar explosives with different names. For this project, information as data and explosive names are going to be taken from Extraco company for being one of the most important in Greece.

As in outdoors mining, blastholes are divided in bottom charge, column charge and stepping. Bottom and column requires different type of explosives, at the bottom of the blasthole is required big amount of breaking power to break the rock mass, as long as in the column the most interesting parameter is the gas volume produced to displace the blasted rock.

The most used explosive at bottom is gelatine-dynamite type while the quintessential column explosive is ANFO because of its low price and the big gas volume produced in its detonation, however, nowadays emulsions are gaining importance. It's flexibility on fabrication allows their use both in bottom and column being, more secure to manipulate than the conventional explosives. Another advantage of emulsions is the possibility of use them liquid instead of employ explosive cartridges improving the explosive charging time.



For this working the use of emulsion at the bottom and ANFO in the column will be considered.

### Burden

Burden is defined as the distance from the bottom of the blasthole to the nearest free face. In tunnel blasting let's consider, at the beginning of the blasting, the free face as the tunnel face and the expansion blastholes of the cut. Several methodologies can be employed to calculate the whole blasting, Langefors, Gustafsson or Johannessen are the most known among other methodologies.

Langefors define the burden as the distance between the centre of the blasting blasthole and the expansion one as seen on Figure 25. The burden will be 1,5 to 1,7 times the diameter of the expansion blasthole according to this methodology.

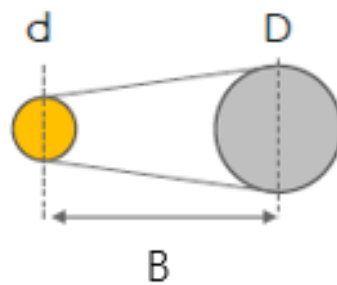

Figure 25. Langefors

Gustafsson considers the burden as the distance between the edge of the both blastholes as shown on Figure 26 and considers the value of the Burden as 0,7 times the diameter of the expansion blasthole.

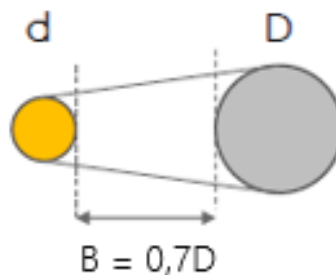

Figure 26. Gustafsson

The selection of one or another method will depend on the experience of the engineer.

### Timing

As consequence of the containment of the rock and the lack of free faces the delay timing must be bigger than in outdoors blasting, employing what is known as long delays. The minimum delay time between blastholes is from 75 to 100 milliseconds (Professor Martínez Torres, [2018](#)).

Another important tip on timing is that the detonator numbers must not be repeated on the cut and no more than one time on the contra-cut.

### Pros, Cons and Limitations

D&B is one of the most used excavation methods on the frame of tunnel excavation both in mining and civil working, and this is due to its different advantages. These are:

- Reasonably good advances
- Allows the excavation of every section
- Allows the excavation of every geometry
- It is easily adaptable to changes on the rock mass or excavation conditions

But this method presents also some disadvantages which limit its use in some cases, mainly in urban areas. These disadvantages are:

- Over-excavation of the tunnel section. This is more important in civil working where the final section is determined on the project but that is also a problem in mining.
- Vibrations. The use of explosive induces vibrations on the ground that can produce affectation over nearby structures. The use of drill and blast method in the proximity of urban areas is limited by vibration studies.
- No mining selectivity.

Drill and blast can be applied in every ground the blastholes are able to be drilled and remain open without caving. Its field of application is wide, from hard rocks with elevated UCS to in some cases limestones or almost soils where, according to Franklin classification (Figure 10), correspond to the category blast to loosen. The use of this method is only limited in that cases safety cannot be ensured.

### 3.2.3. Mechanical Excavation

Mechanical excavation encompasses all the excavation methods that are not drill and blast or conventional method. The excavation consists on the use of drilling tools which, in contact with the ground, they overcome the resistance of itself producing the break of the rock in the face of the excavation. Excavation energy is supplied by generally electric engines and is conveyed by a hydraulic system to the excavation tools., this system can also be pneumatic but its use has been replaced for the more efficient hydraulic technology.

In this list we can find, for its importance 3 different methods of excavation as hammers or rippers, road-headers and TBM.

### 3.2.3.1. *Rippers/Hammers*

Inside the mechanical excavation methods, the use of rippers and hammers is the simplest one and the one who entails a smaller degree of mechanisation of the process. Even though, it is possible to attain good performances with their use being, in some conditions the most appropriate excavation method. There are different attachments for this kind of excavation method but, in this document, the focus will be on two of them which are the most important. They are impact hammers and vibro rippers.

#### I. **Production Cycle**

It is important to know the production cycle of an excavation method when we are going to work with it. For these methods, the production cycle is simple as it is composed for four stages as it is shown on Figure 27.

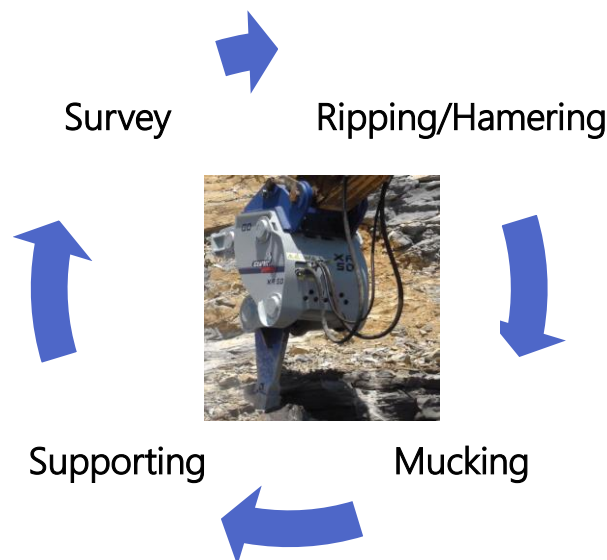

*Figure 27. Production Cycle of Mechanical Excavation*

The production cycle is really simple where the excavation and the supporting stage are the two key parameters. For mucking it exists a great adaptability so, if the ripping/hammering tool is attached on an excavator, the same excavator can be used to charge a truck reducing the costs on the number of rigs.

#### II. **Impact Hammer**

Impact hammers will be considered in this study as long as the use pneumatic ones has become obsolete because of noise and exhaust problems. The use of impact hammers is

widely accepted in the world of mining and civil working. One of the biggest advantages of hydraulic impact hammers is that they can easily be mounted over any type of excavator, as it is shown on Figure 28.

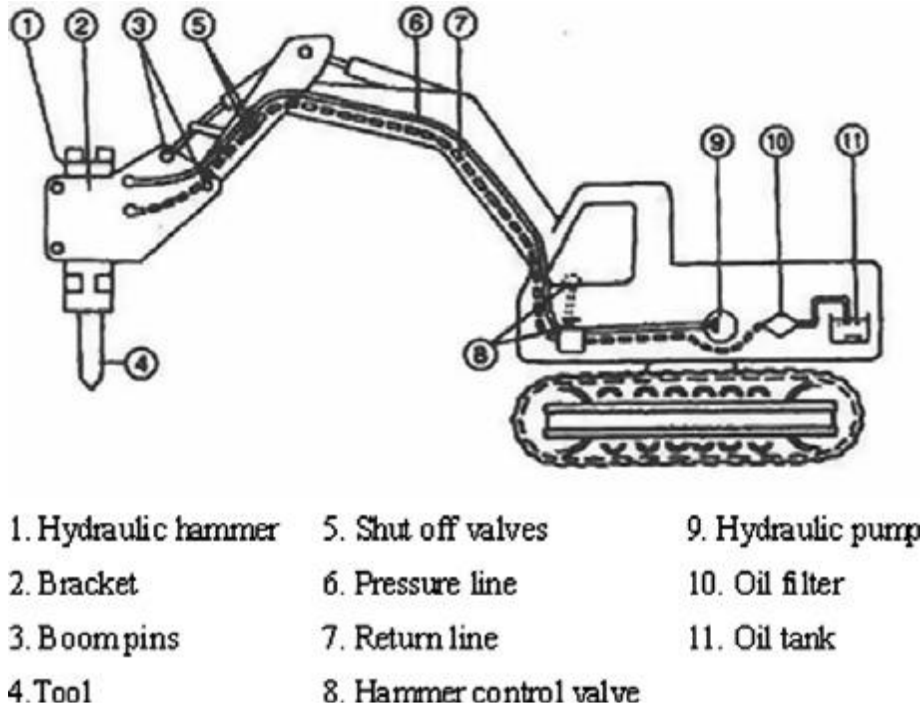

Figure 28. Excavator Carrying an Impact Hammer (Tunçdemir, 2008)

The hydraulic system of the excavator is the system who is going to carry with the movement of the hammer. It is important to keep the equivalence between excavator size and hammer weight in order to good safety and performance during excavation.

The prediction of the performance of the hammer is a key parameter in tunnelling excavation and it is also a very important parameter in this study. The knowledge of the performance of the hammer is going to allow the engineers to define the economy of the excavation. There are some different methodologies to calculate the expected performance of the impact hammers, based on the properties of the rock and the impact hammer specifications, but according to some authors (Bilgin et al., 2002), it can easily be calculated from Schmidt Hammer rebound value in rock formations based on RQD values.

It is important to know the specific energy of the hammer as a rock breaking indicator, so different authors had demonstrated that the specific energy needed to break the rock is inversely proportional to impact energy as it is shown in the following equations (Wayment et al., 1976).

$$S.E. = \frac{k}{\sqrt{\frac{m \cdot V^2}{2}}}$$

Where S.E. is the specific energy, M is the weight of the piston, V is its velocity and k a constant.

Another important parameter is the hammer efficiency. Efficiency is described as the quotient between the output power and the input power. This parameter is estimated on a way that the output power is the 70 – 80 % of the input power (Tunçdemir, [2008](#)). This means special attention must be paid on the election of the hammer as so one with bigger efficiency is going to entail lower operation costs.

For the excavating operation, the hammer must be pressed against the rock of the face of the gallery, this is necessary to keep contact between the hammer and the rock. Therefore is important that the hammer is mounted in a proper sized excavator which is able to press the hammer with the needed force. The components of the hammer are shown on Figure 29. The piston function is the most important and converts the kinetic energy into hammering energy. The hammer is divided in two chambers, the upper chamber and the lower one. The hydraulic flow is directed from the main valve to the upper or the lower chamber, creating a high – low pressure difference between them which is the reason of the movement of the tool.

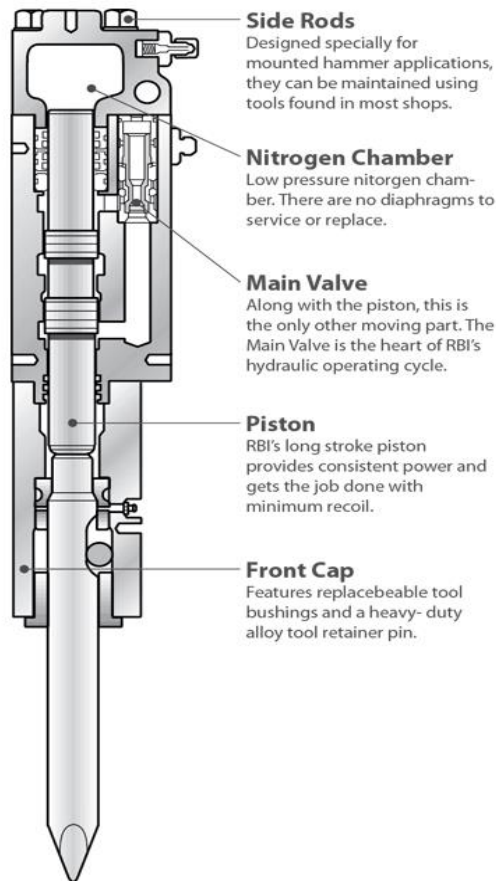

Figure 29. Components of the Hydraulic Hammer (Patel, 2019)

A representation of the excavating process with impact hammer is shown below in Figure 30 and Figure 31 (Bilgin et al., 2002) where the excavation takes place in heading and bench.

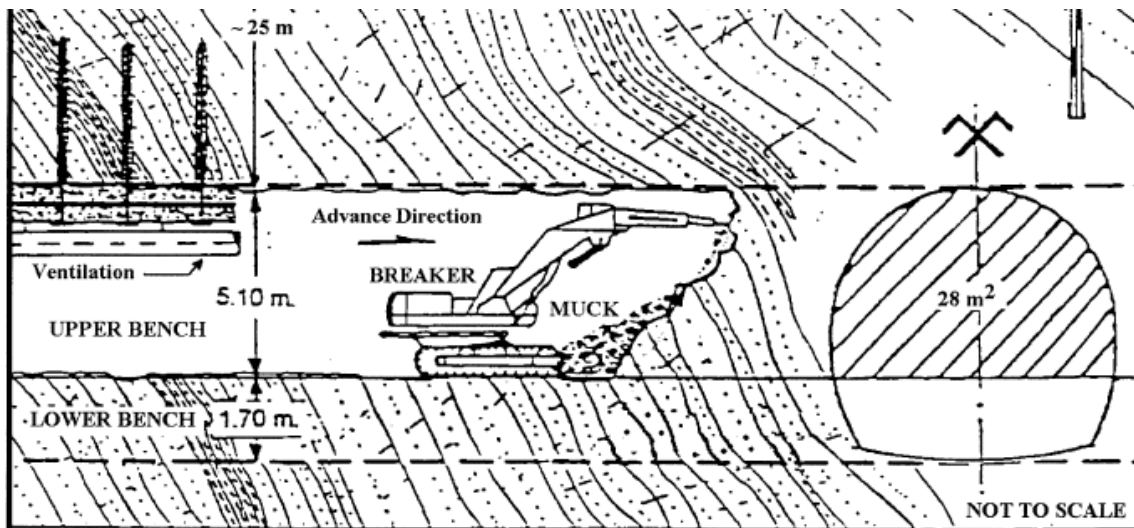

Figure 30. Impact Hammer Excavating in Heading

At the beginning the excavation takes place in the upper part of the gallery to advance the gallery with poor performances for, then, excavate the lower part of the excavation section with open pit mine performances.

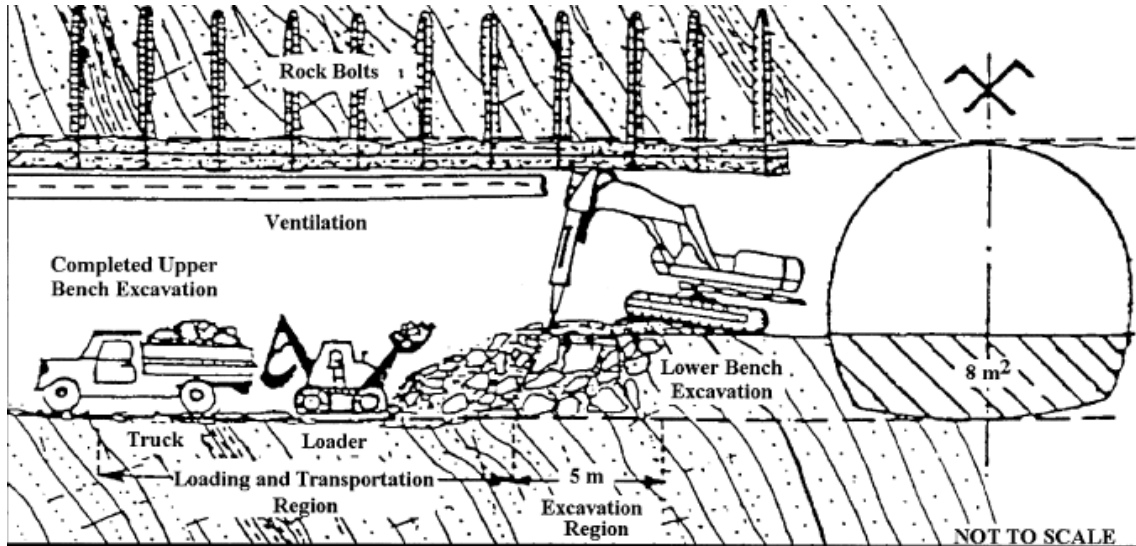

Figure 31. impact Hammer Excavating in Bench (Bilgin et al., 2002)

In comparison to another mechanical excavation methods, as the use of road-headers, impact hammer can excavate in similar or even better performance in jointed rock masses, even more if the rock mass is abrasive. It is due to the bit consumption for the road-header in such conditions is very high, reducing the machine availability time and increasing excavation costs (Ocak et al., 2018).

It is also important to explain that longer the boom of the hammer is, bigger the excavator should be, to be capable of apply the required force over the face of excavation for a proper performance. The way of balance the excavator is shown in the Figure 32.

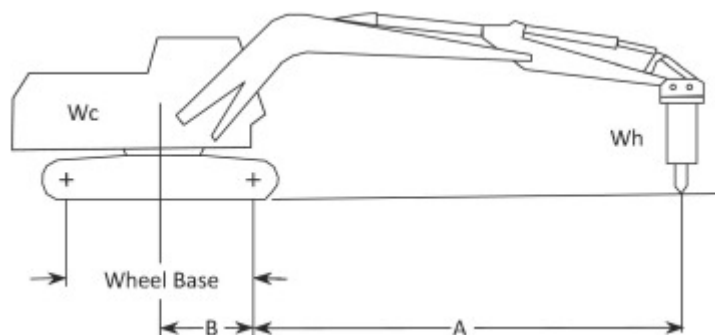

Figure 32. Balance of an Excavator with Impact Hammer

For a proper balance and so, a proper excavation performance, the following relation must be satisfied (Willie, [1985](#)).

$$0,30 < \frac{A \cdot W_h}{B \cdot W_c} < 0,50$$

Where  $W_h$  is the weight of the impact hammer and  $W_c$  is the needed weight of the excavator to be balanced,  $A$  is the distance to the excavation point to the front of the excavator and  $B$  the distance for the centre of gravity of the excavator to the front of itself. If  $A$  and  $B$  are constant parameters, the increase on the weight of the length of the boom of the impact hammer is directly proportional to the increase on the weight of the excavating machine.

### Pros, Cons and Limitations

Impact hammers presents some advantages that favour their use on excavation. These advantages are:

- Possibility of being attached to any kind of excavator
- Big mining selectivity, decreasing the dilution on the excavation process.
- Possibility to scale the working section during the excavation process.

In contrast, its use is limited by:

- Moderate advancing
- Important noise levels

### III. Vibro Ripper

The use of impact hammers is widely accepted on the world of tunnelling as it was explained, but it presents some disadvantages, that explain the rising of vibro ripper technology. The ripper is an attachment as the one shown on Figure 33.



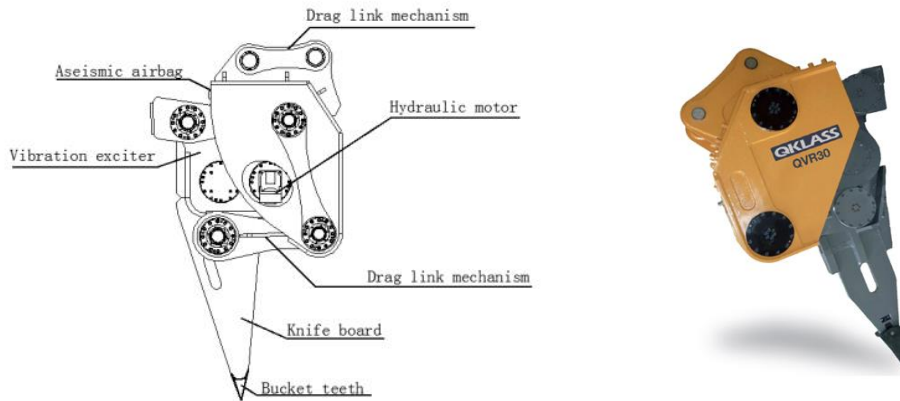

Figure 33. Vibro Ripper Constitution (Wang et al., 2014)

The crushing force is derived from the high speed vibration of the ripper, which is originated on the vibration exciter. The energy needed to produce the vibration is obtained from the hydraulic system of the excavator, the same case that the impact hammer as shown on Figure 28.

To compare both methods some different sources had been consulted as long as every company is working with its own data. The information is going to be presented following is obtained per that sources (XCENTRIC RIPPER, 2019). The advantages the vibro ripper presents over the impact hammer are:

- Production from 2 to 5 times higher
- Lower noise levels
- Lower maintenance costs
- Lower fuel consumption for produced  $m^3/ton$
- Lower consumption on wear parts

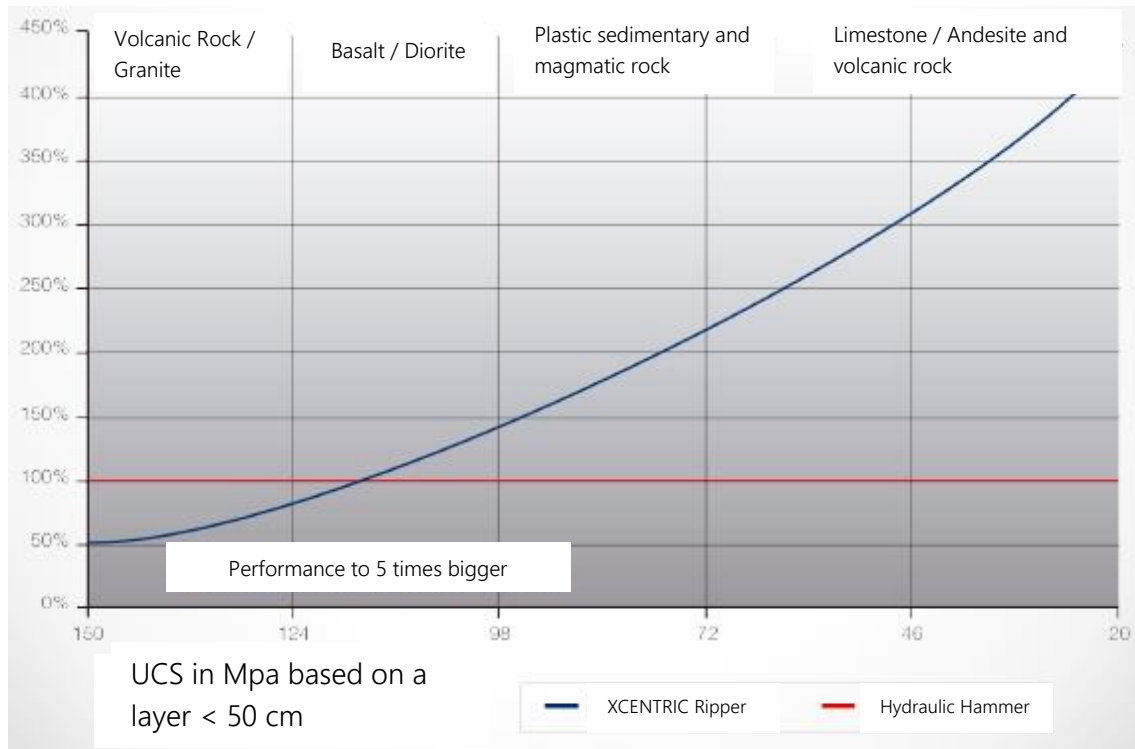

Figure 34. Productivity Impact Hammer vs Vibro Ripper (XCENTRIC RIPPER, 2019)

The comparison between the productivity of both tools can easily be studied by the graph on Figure 34. Hard rocks as granite with high UCS values are difficult to excavate and the performance of the vibro ripper is going to be lower than the hydraulic hammer but, as the rock UCS decreases the performance of this technology increases exponentially. The use of vibro ripper is limited by performance in about 100 MPa UCS. As it can be seen in the previous diagram, over 100 Mpa the performance of vibro ripper drops behind impact hammer being its use discarded.

The process of excavation with the vibro ripper starts positioning the excavator crawlers facing the excavation. Once the excavator is prepared, the ripper must be positioned on 90° with the excavation point or slightly sloped through inside the vertical. Once the excavator and the attachment are positioned the breaking process can start actuating the vibratory movement of the ripper.

### Pros, Cons and Limitations

Vibro ripper technology solves some of the problems that limits the use of the impact hammer. Some of its advantages are:

- Vibro ripper provides better excavation performances in almost all rock UCS spectrum than impact hammer and so better advances.
- Lower noise levels are produced by vibro ripper

One drawback however is that vibro ripper, as already stated, is unable to excavate hard rocks with elevated UCS as efficiently as impact hammers.

### 3.2.3.2. Road-header

Road-header machines were first developed in the 40s on underground coal exploitations, but nowadays their field of application has increased due to performance increases as consequence of technological development. The most important improvement on the last years is related with machine weight, size and cutterhead power if other developments as metallurgical improvement in cutting bits or advances in hydraulic and mechanical system (Copur et al., 1998). On the study of this kind of equipment, the two most important parameters are the weight of the machine and the power of the heading cut.

The excavation with this machines takes place through the rotation of the cutting head, the interaction between the drilling tools and the ground will generate a contact zone, that contact zone will evolve to a crushed area in front of the drilling bit and the first joints will be produced. In the end, fragments of rock will be separated from the country rock. The described procedure can be consulted in Figure 35.

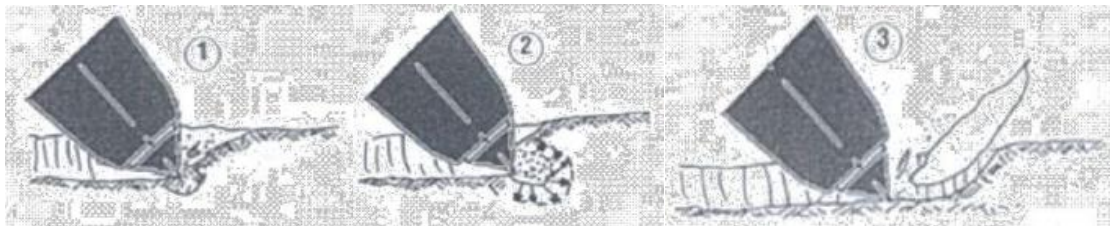
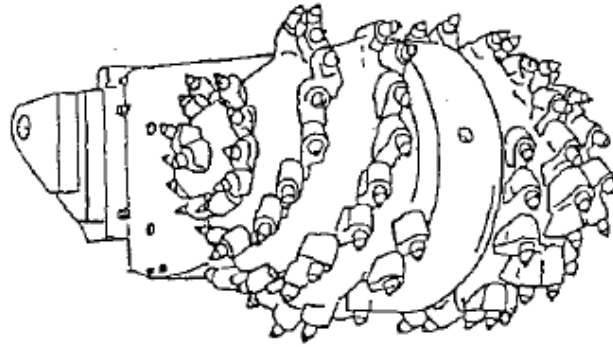

Figure 35. Break Mechanism of the Rock under Roadheaders

There are two different systems of attacking the face of the excavation, these two methods are known under the name of ripping and milling and the difference between them is the axis of rotation of the cutterhead as will be explained.

#### I. Ripping

In the ripping system, the rotation of the cutterhead is parallel to the face of the gallery. The head is made up for two rollers provided of drilling tools as it is shown on Figure 36.



*Figure 36. Ripping System Head*

The excavation movement will be, Figure 37, horizontal. The operation will start at the top of the gallery and it will be going down until the floor of the tunnel with horizontal movements. The movement of the of the cutterhead, in an axis opposite to the advance of the tunnel is going to difficult to achieve the desired geometry, but the results are going to be very close to it.

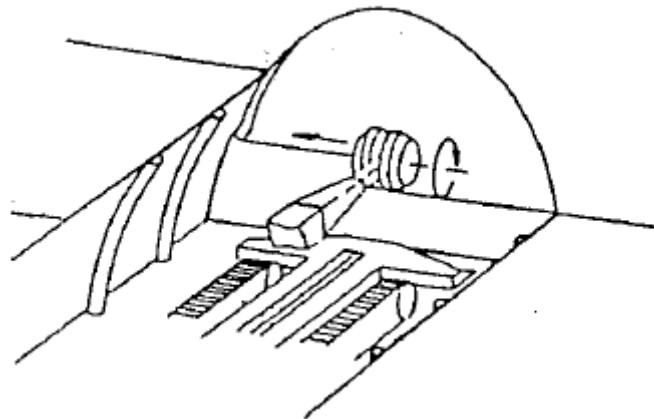

*Figure 37. Ripping Excavation Operation*

In this excavation system, the biggest applied force over the cutterhead is vertical downwards, generating a vertical reaction in the upper direction that will be balanced with the weight of the machine as its shown in Figure 38. This is the reason because the weight of the machine is one of the most important parameters.

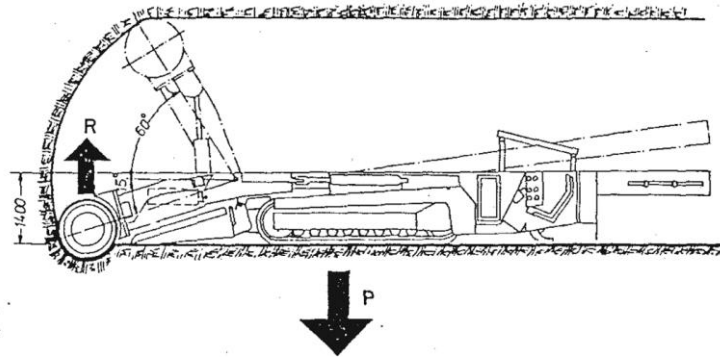

Figure 38. Forces over the Ripping System

## II. Milling

In the milling system, the rotation of the cutterhead is perpendicular to the face of the gallery. The head is made up for only one roller provided of drilling tools as it is shown of Figure 39.

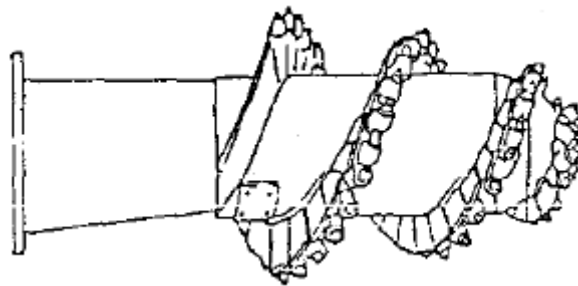

Figure 39.. Milling System Head

The movement of the cutterhead is in the perpendicular axis to the face of excavation or parallel to the advance direction of the gallery, as shown in Figure 40. This movement helps the milling system to achieve the desired final geometry of the tunnel with very good results. The excavation movement, as the ripping excavation movement starts at the top of the gallery to the floor of itself.

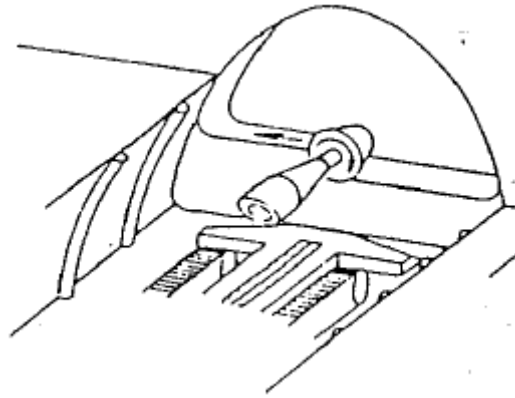

Figure 40. Milling Excavation Operation

Due to the movement of the cutterhead in this case is not parallel to the excavation face but is perpendicular, it will appear a new force. This new force is the biggest force and it is going to be lateral and parallel to the excavation face. It will be required a new force, opposite to this one to balance the road-header and this force is the friction between the machine and the ground as it is shown on Figure 41. In some cases, the friction is not enough to balance the forces and it is needed to anchor the machine over the drift walls, what entails a decrease of the excavation performance.

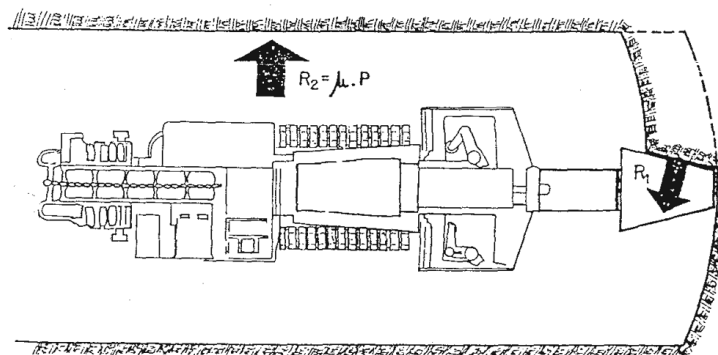

Figure 41. Forces over the Milling System

### Comparison Between Ripping and Milling

When comparing both methods, there several parameters are needed to study as the final geometry of the excavation, the power required on the cutterhead or the weight of the rig

Due to the design of the head, the scaling of the gallery is going to be different on both methods as it was told previously. It is explained on Figure 42 where is possible to see how milling method provides a better scaling than ripping due to the axis movement of the cutterhead.

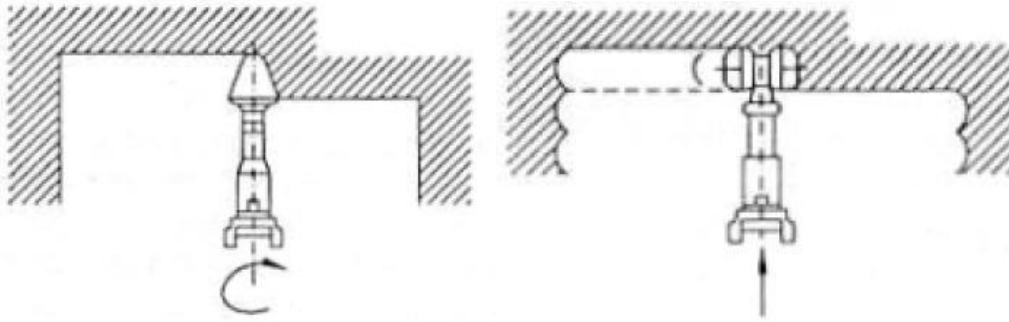

Figure 42. Milling (Left) and Ripping (Right) Scaling

As it was explained previously, with this kind of excavation rig is necessary to balance the forces. The ripping system is submitted to a force with a vertical compound and can be balanced with the proper weight of the excavation rig, in the other hand, over the milling system, the principal force has an horizontal compound, so it must be balanced through the friction between the rig and the ground, been necessary a bigger weight per installed cutting power than the ripping method at is shown in Figure 43.

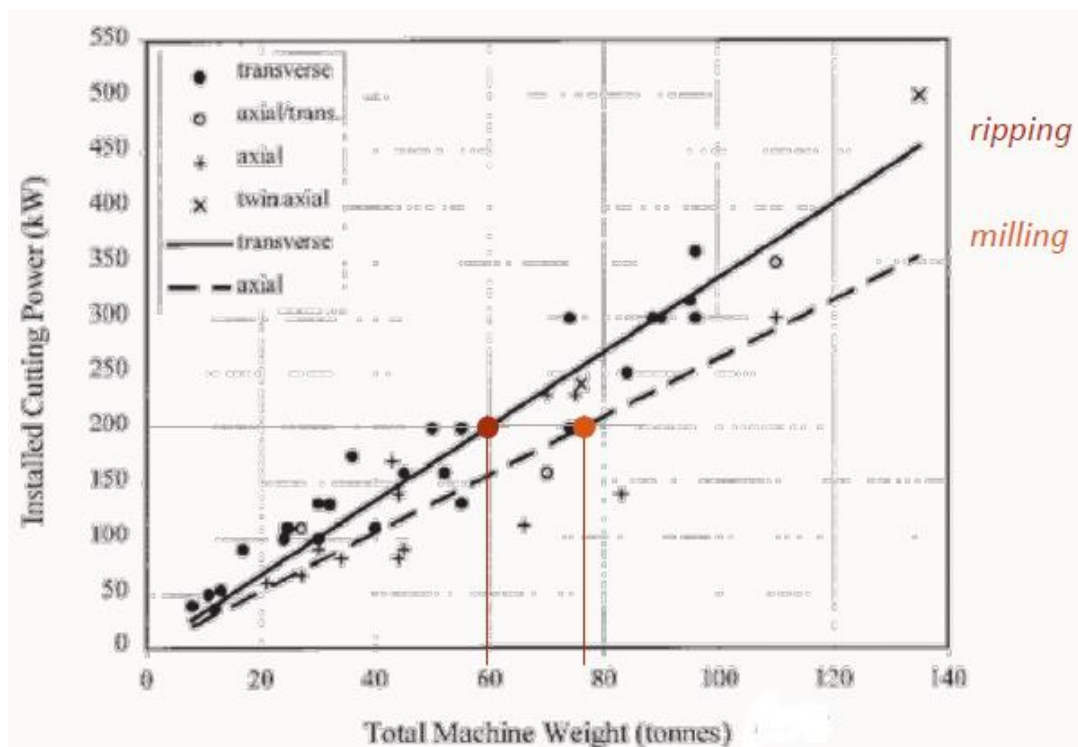

Figure 43. Power vs Weight for Ripping and Milling System

The installed power of the road-header is calculated in function of the geotechnical characteristics of the rock, so it is a constant parameter. What the graph shows is that, for

a constant power of the cutterhead, on the milling system is going to be needed a heavier rig and, thought, a bigger one.

### Pros, Cons and Limitations

The use of road-headers allows full size gallery excavation. In comparison with the impact hammer and the vibro ripper the mechanisation of the method is bigger so it provides better performances. Also, with milling technology scaling of the section is no needed achieving the desired geometry during excavation.

Vibrations produced during the excavation are lower than using drill and blast method, so road-headers are going to be dominant on rock excavation in areas where vibrations must be controlled under a certain limit, as in urban areas, the same that happen with impact hammers or vibro ripper.

The use of vibro ripper is limited by the section of the gallery. If the section is so big it needs to be excavated in heading and bench decreasing the performance of the method.

### 3.2.3.3. *Tunnelling Boring Machines (TBM's)*

In the frame of mechanical excavation, tunnel boring machines entails the complete mechanisation of excavation and supporting. TBM excavates the gallery in full section by mechanical excavation while they apply the definitive support on the excavation. The usual excavation is in circular cross section. The biggest advantage that TBM presents is the possibility of excavation on any kind of soil or rock with any kind of geological or geotechnical characteristics, and even under phreatic levels.

The excavation performances through the use of TBM are the biggest between all the excavation methods due to the integral mechanisation of the excavation and support process. Its use depends only on economic criteria due to the big initial investments there are needed. Nevertheless, this is the case only when the ground conditions are relatively uniform and compatible with the TBM machine that is usually tailor-made for such conditions. If changing or inhomogeneous rock structures are encountered, in general delays and decreased utilisation rates can be experienced.

When describing TBM is needed to talk about two parts, the head and the back-up. The head is composed for the cutterhead, a system for collecting the excavated material, the shields to protect the head and to give the tunnel a temporary support and the translation system, while the back-up is formed by a combination of rigs which support the whole installation as the cockpit, the electric transformers or the ventilation system. The different types of TBM presents differences on the design as it is going to be explained.



### I. Hard Rock TBM

When the excavation takes place in rock with good geotechnical properties, the equipment used will be the hard rock TBM. This kind of rig, as the one shown on Figure 44 advances by the movement of the grippers directly over the drift walls of the gallery.

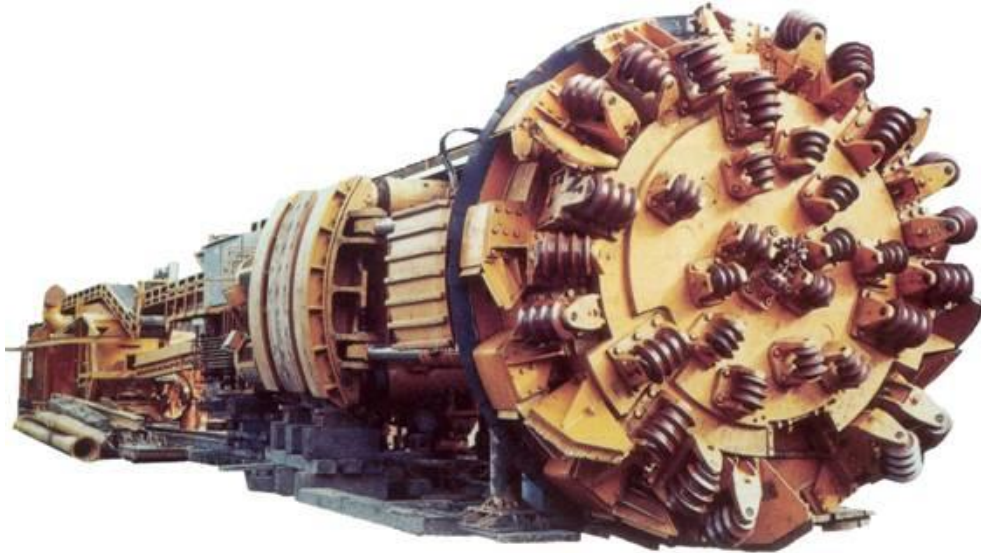

*Figure 44. Hard Rock TBM*

The cutterhead is made up for drilling bits which excavates the rock in a similar way the road-headers do. The largest concentration of drilling bits on the middle of the head have the mission of acting as a cut creating relief on the excavation face.

### II. Soft Ground TBM

When the excavation takes place in soft grounds or under phreatic levels soft ground TBM is the most suitable excavation choose. The excavation tools are picks instead of bits. The big difference with the hard rock TBM apart from the excavation tools is the installation of segmental lining as definitive support. This increases the initial investment of the method so is needed the installation at the tunnel mouth of a segmental lining plant. An example of this kind of machine is shown on the following figure.

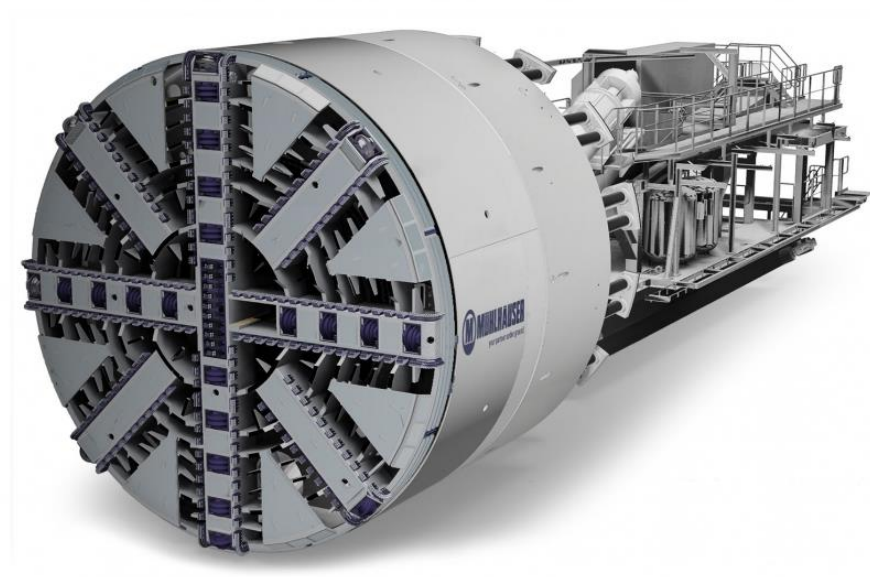

Figure 45. Soft Ground TBM

There are another TBM types as the double shielding TBM, a combination of hard rock and soft ground technologies or the micro-TBM, designed for small sections (lower than 3 square meters)

### Pros, Cons and Limitations

In comparison with the conventional construction methods, TBM provide big advantages in safety and production. They allow to achieve better results in execution period and in costs per meter of excavation. More particularly:

- Support on the face of excavation provides high levels of safety
- Possibility of excavation of every kind of ground or rock, even under the phreatic level
- Minimum surface disturbance being the best choice to work in urban areas.
- High advance performance among all excavation methods.
- Simultaneous installation of the final tunnel support
- Perfect excavation geometry with minimum over-break problems.

Obviously, the TBM is a preferred method with high potential in terms of performance and safety, even though there are limitations that can hinder its use. Some of these are:

- Big initial investment is required for the purchase of the machine, limiting their applicability only in long tunnels.
- It is impossible to modify the cross-section design of the gallery to shapes different than circular.
- Poor adaptability to differing geological or geotechnical conditions.
- Extended time requirements for the manufacturing of the TBM.

## 4. Comparison between Drill and Blast and Mechanical Excavation Methods

As was already showed in this document there are two major methods of excavation, drill and blast methods using explosives and excavation through mechanical methods. In this point, both methodologies are going to be compared.

### 4.1. Mechanical Excavation vs Drill and Blast

#### 4.1.1. Impact Hammer vs Drill and Blast

Impact hammer and D&B are two different methods of excavation. Impact hammers present some advantages over D&B excavation as (Ocak et al., [2018](#)):

- Reduced timing in transport to the tunnel face (only excavator) which entails bigger utilisation time
- No over-excavation. This means scaling is going to take less time and the costs are going to be reduced
- Lower ventilation requirements as long there is no blasting smokes to evacuate
- The level of the produced vibrations is lower than in blasting

It can also be considered the simplicity of the excavation with the impact hammer as an advantage if the number of excavation machinery is fewer (the same excavator which is drilling can load the excavated material), so the initial investment will be lower and also the maintenance cost of all the excavation rig.

There are two important points on the advantages of the impact hammer over drill and blast method. The first is the over break excavation which is a big problem in the D&B method. The section of the tunnel is defined by the project and because of this, concrete must be used to achieve the final desired section increasing the cost of the excavation. Bigger over-excavation entails larger requirements of concrete, and more concrete volume, resulting in higher tunnel costs.

Vibration the other point to discuss about. One of the biggest problems of drill and blast method presents is the impossibility of its use on urban areas or in the proximity of protected structures. In some cases, its use is not forbidden but the operative loads allowed are so low that the method is not worth to be used.

Instead, drill and blast presents some advantages over mechanical drilling with hydraulic hammers which make this method more interesting to use. Some of that advantages are:

- Great adaptability to changes on the excavation process
- Possibility of be used in every kind of rock mass or soil
- Bigger advance rate

Drill and blast presents the advantage that the blasting design can be modified according with the changing characteristics of the rock mass, so its adaptability to the changes is

bigger. It also has no limitation on the type of ground and is able to be used in every rock mass or soil where the blastholes remain unaltered.

#### 4.1.2. Vibro Ripper vs Drill and Blast

Comparing drill and blast with vibro ripper is quite similar to the comparison with the impact hammer. The biggest difference is that vibro ripper presents better performances and a lower application field than the impact hammer, as long its use is limited in 100 Mpa UCS.

According with the information contributed by the XR company (XCENTRIC RIPPER, 2019), the choice of vibro ripper or drill and blast method can be done with respect to UCS and Rock Quality Designation (RQD), using the nomogram of Figure 46.

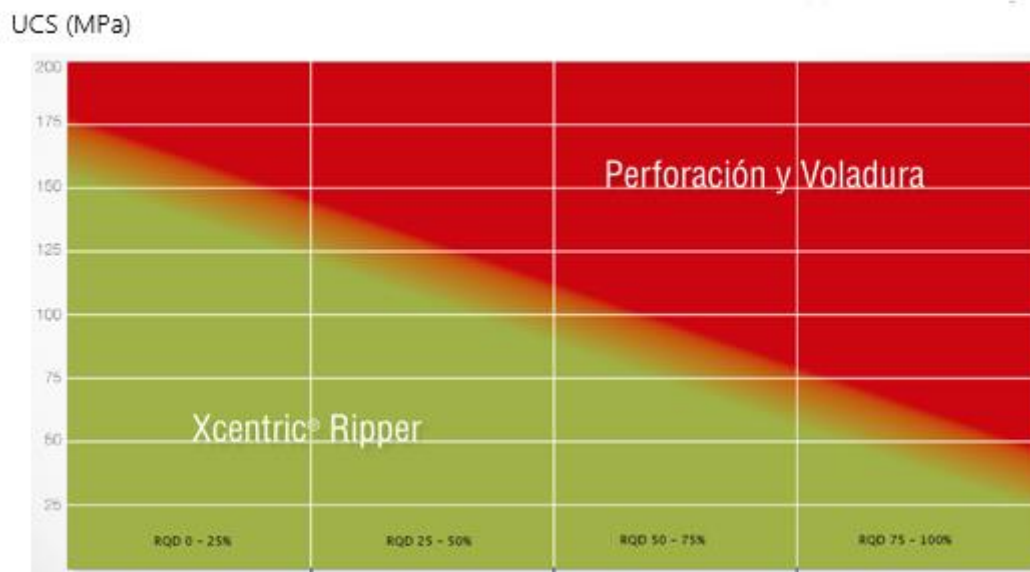

Figure 46. Drill and Blast vs Vibro Ripper (XCENTRIC RIPPER, 2019)

This nomogram shows the field of application of D&B (red) and vibro ripper (green) over rock mass UCS on the Y axis and RQD on the X axis. Regarding the graph, for a given RQD value if the UCS increases D&B method is more suitable than vibro ripper. The same happens for a given UCS value, where, if RQD increases D&B is preferred over mechanical excavation. According to the graph there exists a well-defined area where drill and blast method and vibro ripper are the best method, but there is also an area where both methods collide. This will be the objective of this project, try to define, inside the contact area when one method is preferred to the other one.

#### 4.1.3. Road-header vs Drill and Blast

Road-headers are the most suitable excavation method under particular conditions, this is small sections which allow the excavation of the full face at the same time and short transportation times. Out of this conditions this method is ruled out.

## 4.2. Model Tunnel Excavation

Before to go inside the cost assessment is necessary to describe which are the excavation conditions under which this study will be developed and the suppositions it has been made.

The first point is to define the conditions of the tunnel which is subject of the study. A model tunnel is going to be considered and its excavation through D&B and vibro ripper considered. The model tunnel under both excavation methods is going to be submitted to the same geological conditions and the same characteristics as section or length.

The tunnel considered has the following characteristics:

- 1.500 metres length.
- 30 m<sup>3</sup> section.
- Arch tunnel section.

The following machinery was considered:

- Jumbo for drilling in D&B method and for rock-bolting in both excavation methods.
- Load Hold Dump (LHD) for mucking in both methods as long as the transportation under the use of excavator loading trucks was also considered on the model.
- Shotcrete machine for shotcrete application in both excavation methods.
- Excavator for scaling the tunnel section

The following staff was considered:

- Jumbo needs to be operated a driller and a roughneck (helper).
- Shotcrete Machine needs to be operated an operator and a helper.
- LHD needs a driver.
- Excavator and Trucks, in case of being considered need a driver.
- Geologist/topographer is needed for survey.
- General staff as mechanic, engineers, officer and construction manager are considered and its cost is divided between all the stages in the production cycle.

For this design the following assumptions has been made:

- Supporting is applied to 2/3 parts of the excavation perimeter, been the last 1/3 the invert.
- In mechanical excavation method mucking chores can take place during excavation, being mucking time considered will be between 40 and 50% of the total needed, being used 45%.
- Truck drivers will also be the gunners during the charge step of the process. In the same way, the driver of the excavator could be a gunner if more people is needed on the charging process.

- Gunner and roughneck on the drilling process will also be the responsible staff of the use of the shotcrete machine.
- Damage over the rock mass will be considered a 5% lower for vibro ripper method.

### 4.3. Cost Assessment

Cost and time required for the completion of the excavation or tunnel are the key parameters in the selection of the most suitable excavation method. For its calculation is needed to consider:

- Time is a stand-alone performance indicator, is the most important parameter to know as long all the study is based on the times.
- Cost management requires the knowledge of time to allocate the resources and to be able to assign price for their use.
- There are capital and operational expenses. Operation costs are derived for the commissioning of the equipment (fuel, wear parts and expendables, maintenance and reparations) meanwhile capital or property expenses are associated with the amortisation of the resources.

According to project management techniques (Project Management Institute, [2004](#)), time management should be considered as it follows

1. Plan Schedule Management
2. Define Activities
3. Sequence Activities
4. Estimate Activity Resources
5. Estimate Activity Durations
6. Develop Schedule
7. Control Schedule

Activities are defined and sequenced inside the production cycle of every method, 3.2 Types of Excavation, and resources are also defined, and will be assigned further on this document as long the estimation of activity durations. Schedule will be developed after estimation and control is out of this document objectives.

Cost assessment start from the design of the work needed to carry out the selected task, in this case the tunnel construction. Once the design has been made the resources required are estimated and also the whole scheduling is assessed. In this manner the cost assessment for each unique work can be made accurately. Estimate costs is an approximation of the monetary resources needed to complete project activities. The key benefit of this process is that it determines the amount of cost required to complete the project work. Costs must be estimated for all resources that will be charged to the project (Project Management Institute, [2004](#)).

Employing again project managing techniques cost management should be understood in the following way:

1. Plan Cost Management
2. Estimate Costs
3. Determine Budget
4. Control Costs

In this document cost analysis is not going to be so exhaustive, this is just a comparative study and not the development of a real project. The key point for cost analysis in this document is cost estimation.

Therefore scheduling and time allocation for each task is the starting point that will allow for the estimation of the whole production cycle of both methods, drill and blast and mechanical excavation. The differences between these two methods will be highlighted and through them the final assessment of the productivity and cost of each method will be revealed.

## 5. Analysis

It is the moment to start developing a methodology to allow engineers to decide the most suitable excavation method. For the analysis of the data an Excel file has been created. In that file costs and timing are not fixed values but rather inserted as relative functions influenced by all the parameters that have an effect on them. This is something that is mainly associated with the rock mass conditions and the uncertainty that the ground conditions have. In the following pages, how that file was programmed and how the calculation regarding general costs and timing for every parameter considered is going to be presented.

### 5.1. Data

One of the first points needed to face on the planning stages of an excavation project is to select the number of work shifts. The number of turns is going to define the number of workers recruited for the whole excavation work, having in mind that one more turn will be needed to rotate all the staff. For that is necessary to define at first the total work hours per day and then the length of the journey.

Once the number of shifts is decided, the next step is to break the excavation process in small pieces and study every piece separately. Let's start from the drill and blast method.

### 5.1.1. Equipment and Staff Cost Data

Previously to the start of the study of the excavation process is necessary to present the cost data was used for the staff and the machinery. The costs for the equipment are divided in the operational and the property/amortisation costs as it is explained in paragraph 4.3 Cost Assessment.

Table 2 collects the costs related to the equipment used for the case of D&B method.

*Table 2. Costs of the Mining Rig (Professor Benardos, 2019)*

Cost [€/h]	Jumbo	LHD	Articulated Trucks	Shotcrete Machine
Operation	35	50	60	30
Property/Amortisation	14	26	28	12

In the upper table the use of a load-hold-dump was considered. The use of this kind of machinery is common in mining but not in tunnelling. Also a LHD is not able to realise scaling operations but its cost is going to be employed for the development of this study. For the transport operation has been considered both the use of the LHD excavator and the use of trucks.

In terms of staff remuneration and cost data, these are given in Table 3. In there, the cost per hour is given taking also into account the social security data as paid by the employer. The payment is differentiate between skilled and unskilled workers.

*Table 3. Staff Cost (Professor Benardos, 2019)*

Worker	Driller	Roughneck	Excavator	Driver
Cost [€/h]	14	10	14	14

Last but not least, is necessary to consider the cost of the pay check of the engineers, mechanics and the rest of the staff. As it was told before, the costs in this thesis are going to be considered by advanced meter. Table 4 shows the data in € per year so it is necessary to transform it.

*Table 4. Personnel Cost (Professor Benardos, 2019)*

Worker	Construction Manager	Engineers	Officer	Mechanic	Topographer / Geologist
Cost [€/year]	55.000	45.000	22.500	30.000	45.000



To transform this costs the first thing we need to know is the duration of the excavation. Known the length of the excavation and the advance rate it is possible to calculate this value.

$$\text{Duration of Excavation (days)} = \frac{\text{Excavation Length (m)}}{\text{Advance Rate } \left(\frac{m}{d}\right)}$$

Next step is the calculation of the cost per meter as it is desired. This is done in the following way.

$$\text{Cost } \left(\frac{\text{€}}{\text{pass}}\right) = \frac{\text{Annual Cost } \left(\frac{\text{€}}{365d}\right)}{\text{Duration of Excavation (d)}} \cdot \frac{1}{\text{Number of Passes}}$$

Once the cost per pass is know there is only left to divide it by the advance in every pass. The cost of all this staff in exception of the geologist/topographer will be divided between all the operations in the production cycle.

### 5.1.2. Drill and Blast

In this way, the total number of workers is the lowest possible which entails a reduction of staff costs. Good management of human resources is key in a good working organisation.

#### Survey

In mining and in civil works beneath the NATM excavation conditions, survey is an important part of the production cycle and takes an important role on the supporting selection. Also in mining, a proper survey is needed to analyse how the mineral vein is varying in cut-off grade or dip.

In this part of the work, a geologist/topographer is considered as part of the working staff, associated to survey in the production cycle as responsible of geology and topography.

#### Drill

Let's start the analysis of the drilling. As it was explained timing and cost are the two parameters needed to calculate, but for the calculation of the costs is necessary to know at first the timing of the process.

Drilling rate index is the main parameter which defines the drilling performance. It was defined previously in this document (3.1.2 Drillability) but basically it is use to predict the performance of the drilling. Table 5 shows the drilling rate index values will be considered

in this study. Maximum and minimum values are known (Professor Benardos, 2019) so considering the drilling rate graph, Figure 11 is possible to suppose the variation is lineal.

Table 5. Drilling Rate

Q (Barton)		Quality	Drilling Rate (m/min)
0	0,01	Exceptionally Bad	2,50
0,01	0,1	Extremely Bad	2,39
0,1	1	Very Bad	2,28
1	4	Bad	2,17
4	10	Medium	2,06
10	40	Good	1,94
40	100	Very Good	1,83
100	400	Extremely Good	2,83
400	1.000	Exceptionally Good	1,50

Of course, drilling rate is related with the geomechanical classification of the rock mass because more competent grounds are, more difficult is the drilling operation over them (3.1.1 Excavability)

To this excavation time, is needed to add the positioning timing for the boom of the jumbo, that time will be 1 minute per blasthole. It is also a variable important to know, the number of booms of the jumbo, which will be between 1 and 3.

The drilling length and the number of blastholes are defined by the blasting design and the tunnel section.

Known all these parameters, the timing can be calculated as:

$$\text{Drilling Time} = \left( \frac{\text{Total Drilling Meters}}{\text{Drilling Rate Index}} \right) + (\text{Positioning Time} \cdot \text{Number of Blastholes})$$

So once the total timing of the drilling operation is known, is possible to calculate the cost of the whole drilling process. The total cost will be the cost of the drilling rig, one jumbo, plus the cost of the drilling staff (driller and roughneck) and the cost of the wear parts of the drilling rig.

Known the property and operation costs of the machinery (machine cost) in € per hour, and knowing the timing of the drilling part on the production cycle the machine costs are considered. It is time to focus now on the wear parts of this equipment.

The most important wear parts of the jumbo are the drill bits and the drill steels. There are also another wear parts as the tyres or the lights but in this work only these two will be considered. The cost of each is known and also its life span, given in Table 6, so to calculate

the total cost produced by the wear during excavation is mandatory to know the total drilling meters (calculated through the blasting design and the length of the tunnel).

Table 6. Wear Parts Cost (Professor Benardos, 2019)

	Drill Bits	Drill Steels
€/piece	50	245
Life Span [m]	500	5.000

The total cost is going to be calculated as shown:

$$\text{Total Cost (€)} = \frac{\text{Total Perforation Length (m)}}{\text{Live Span (m)}} \cdot \text{Cost of Wear Part (€)}$$

The total cost of the drilling process will be the sum of the individual costs.

$$\text{Drilling Cost (€)} = \text{Jumbo Operational Cost(€)} + \text{Personal Cost(€)} + \text{Wear Parts Cost(€)}$$

### Charge

For charging the blastholes the time is variable only on the number of workers. Charging time is defined as 2 minutes per blasthole so knowing the total number of blastholes from the blasting design the timing is going to be calculated as:

$$\text{Charging Time} = \frac{\text{Blastholes Number} \cdot \text{Charging Time} \left( \frac{2 \text{ min}}{\text{Blasthole}} \right)}{\text{Number of Workers}}$$

For the charging cost, according with the explained on 5.1.2 Drill and Blast, the workers with the mission of charging the blastholes are the drivers, so the hour cost considered will be the driver's hour cost.

### Blast

To calculate the timing and the cost of the blasting is first needed to calculate the blasting. As it was described before in 3.2.2 Blasting, there are different methodologies to calculate blasting in underground activities.

As is known, the most important part on blasting is the cut, its importance is such that the tunnel advance per pass is determined for the cut advance. For this design, the easiest cut to calculate, the four sections cut (Figure 23), will be employed, obtaining the design parameters of Table 7. In this calculation is important to consider the diameter of the expansion blastholes, for what was considered a drilling diameter of 113 cm.

Table 7. Four Section Cut Calculation (Holmberg, [1982](#))

Cut		
Section	Burden	Spacing
First	$B_1 = 1,5 \cdot D$	$X_1 = \sqrt{2} \cdot B_1$
Second	$B_2 = \sqrt{2} \cdot B_1$	$X_2 = \sqrt{2} \cdot B_2 \cdot 1,5$
Third	$B_3 = \sqrt{2} \cdot B_2 \cdot 1,5$	$X_3 = \sqrt{2} \cdot B_3 \cdot 1,5$
Fourth	$B_4 = \sqrt{2} \cdot B_3 \cdot 1,5$	$X_4 = \sqrt{2} \cdot B_4 \cdot 1,5$

Once the cut is designed is possible to calculate the drilling length and the expected excavation pass. This is function of the expansion blastholes diameter and is calculated in the following way (Professor Martínez Torres, [2018](#)):

$$\text{Drilling Length} = 0,15 + 34,1 \cdot D - 39,4 \cdot D^2$$

Where D is the diameter of the expansion blastholes, where a value of 113 mm has been used.

The expected advance of the pass is calculated as the 90% of the drilling length. If the achieved advances are lower than this value, the cut must be redesign.

In this point is important to say that the drilling length in low Q rock masses must be lower due to it is impossible the boreholes remain open. The same happen with the advances, so the advances are calculated for the previous equation.

Table 8. Blasting Advance

Q		Advance (m)
0	0,01	1,1
0,01	0,1	1,1
0,1	1	1,6
1	4	2,2
4	10	3,3
10	40	3,3
40	100	3,3
100	400	3,3
400	1.000	3,3

The calculation has been made for an advance of 3,3 metres, but this kind of advance is not possible in any kind of ground, so for Q from 0 to 0,1 three advances of 1,1 metres were considered, for Q between 0,1 and 1 two advances of 1,6 metres were considered, for Q between 1 and 4 one point five advances of 1,5 metres were considered and for the rest of cases only 1 advance of the total length.

The next step after the cut is to design the rest of the blasting, this is blast, lifters and contour. Lifters and contour are designed with contour techniques as crosscut and decoupled explosive, but this is not the place to focus on in this paper. Blast and contour will be calculated in the same way. For the main blasting calculation, the design can be made in two ways, consider bottom and column with different explosives, this is the way is going to be done, or consider the use of emulsion in all the length of the blasthole due to its ease to fill the blastholes which is also a common methodology nowadays.

The chosen explosives are EM-EX emulsion explosive in bottom and Petrammonitis - AN-FO in column (Extraco SA, 2019). Selected the explosive the next stage is the calculation of the linear charge density.

$$l \left( \frac{kg}{m} \right) = \frac{\rho \left( \frac{kg}{m^3} \right) \cdot \pi \cdot d(m)^2 \cdot f}{4}$$

The value of the linear density must be around 2 kilograms per meter for the bottom and 1,3 on the column even though in mining this value can be lower. The value of the specific charge must be between 2 and 2,5 kilograms per cubic meter and it is possible to be calculated as:

$$\text{Specific Charge} \left( \frac{kg}{m^3} \right) = \frac{\text{Total Charge (kg)} \cdot \text{Number of Blastholes}}{\text{Advance(m)} \cdot \text{Section}(m^2)}$$

Finally, to complete the blasting design is needed to calculate the total number of blastholes there are needed to drill. This number will be calculated with help of the chart on Figure 47, assuming a drilling diameter for the blast blastholes of 45 mm. As long the excavation section is 30 m<sup>2</sup> and the blastholes diameter is known, from the graph the number of blastholes is 50.

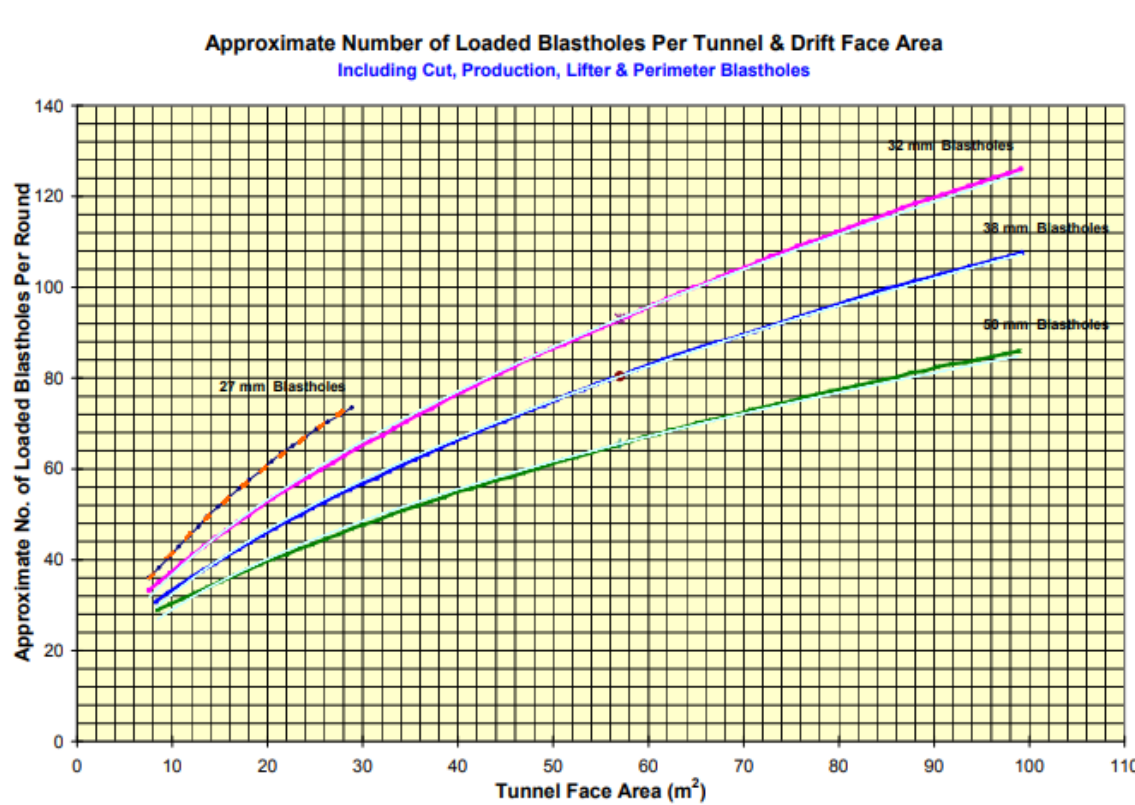

Figure 47. Number of Blastholes (Jimeno, et al. 1995)

At last, just say that for the blasthole structure, it was considered one third part of its length as bottom charge, the stepping length around half a meter and the rest is column charge.

### Ventilation

Is important consider ventilation. Apart for that cases where natural ventilation is enough for the excavation requirements (few cases), is necessary to consider the ventilation of the gallery. The air must be flowing during all the time the workers are inside the tunnel, this means during all excavation operations.

The first consideration is the acquisition of a fan. Typical fans are from 30 to 40 KW and their cost is considered between 3.000 and 5.000 € (Professor Benardos, 2019). If electricity

price is considered as a constant parameter, in this case 0,11 € per KWh is possible to calculate the ventilating cost of the excavation.

$$\text{Cost (€)} = \text{Fan Power (KW)} \cdot \text{Operating Hours (h)} \cdot \text{Electricity Price} \left( \frac{\text{€}}{\text{KWh}} \right) + \frac{\text{Fan Cost (€)}}{\text{Number of Passes}}$$

### Mucking

After blasting the excavation face needs to be cleaned. Mucking operation consists on dislodging the blasted material and its timing must be calculated. It is a variable dependent on the cubic meters excavated in every excavation pass and the swelling factor of the rock. For its calculation, the first step is to know the kind of machinery is going to be used, being able two options:

- LHD excavators which transports the material for the excavation face to outside the tunnel
- Trucks loaded by an excavator on the face of excavation

There are other options as an LHD excavator mucking the material on the excavation face and dropping it on a bigger chamber where an excavator loads the trucks which are going to transport the material outside the tunnel, but for this study we are only going to consider the two simplest methods.

The first step is calculating the total volume of material needed to remove. It will be the section of the tunnel multiplied by the advance of the blasting considering the swelling of the rock with a value of 1,33.

$$\text{Total Volume (m}^3\text{)} = \text{Tunnel Section (m}^2\text{)} \cdot \text{Advance (m)} \cdot \text{Swelling Factor}$$

Once the volume is known, is necessary to assign times to the loading and unloading process. One minute for each will be considered. It is also needed to know the speed of the excavator or the trucks during transport through the tunnel as long as the distance of transport, that will be considered half of the total length of the gallery.

Transport time will be calculated how it follows:

$$\text{Transport Time (min)} = \frac{\text{Tunnel Length (Km)}}{2} \cdot \text{Transport Speed} \left( \frac{\text{Km}}{\text{h}} \right) \cdot 60$$

Known the transport time and the total cubic meters of excavated rock that need to be mucked, the next stage is the calculation of the transport cycles needed to clean completely the excavation face. The only thing is needed to know is the volume of the bucket of the excavator.

$$\text{Transport Cycle} = \frac{\text{Total Volume (m}^3\text{)}}{\text{Bucket Volume (m}^3\text{)}}$$

With all these parameters is possible to calculate the transport timing of the whole mucking process. The way to do it will be multiplying the number of the transport cycles by the transport time.

$$\text{Mucking Time (min)} = \frac{\text{Transport Cycles} \cdot (\text{Load \& Unload Time} + 2 \cdot \text{Transport time})}{\text{Number of Excavators}}$$

In case of considering trucks instead of LHD excavators in the calculation must be considered that the loading and unloading time is different, and that the transport speed is bigger as so it is the volume of its box. The selection of one or the other method will be based on the quantity of material to be evacuated and the length of transportation, which are the variables that defines the mucking time, and in the method with the lower cost.

In the costs estimation is important to consider the cost relative to the use of the excavators, Table 2, and the needed staff, Table 3, relating its costs to the timing of the mucking operations.

### Scaling

Scaling time has been calculated from the drilling rate employed to define the drilling time of the excavation. It was supposed a value (In hours) of the 15% of the drilling rate. One important parameter needed to consider on scaling is the over-excavation produced using explosives. In this case, is first needed to scale the tunnel for safety reasons and then fill the gap with the final geometry with concrete. In case of under-excavation, scaling is excavation with mechanical methods to achieve the final shape of the gallery. Table 9 shows the scaling time have been used in this study.

Table 9. Scaling Time

Q		Scaling Time [h]
0	0,01	0,38
0,01	0,1	0,36
0,1	1	0,34
1	4	0,33
4	10	0,31
10	40	0,29
40	100	0,28
100	400	0,26
400	1.000	0,23



The costs considered as the ones showed on 5.1.1 Equipment and Staff Cost Data.

### Supporting

Support is the most important part on the tunnel designing and eventually the most expensive. Even if it is not part of this work, is needed to dedicate some time to its timing and costs explanation and calculation.

Support calculation is difficult to consider in this thesis because it depends on a large degree on the particular characteristics of every excavation, as number of joints, its orientation and a bunch of other different factors. Because of that, supporting is going to be calculated per Barton classification. As in every working, supporting has been divided into three categories, as shotcrete, rockbolts and steel sets. The graph on Figure 48 shows Barton's Q-system classification with respect to the support recommendations.

It is important to consider that Barton is very optimistic on the support he suggests because its classification is based on the Norwegian excavation method (Cafá et al., 2019), and the use of shotcrete in this method is lower than in the New Austrian Modified Method, anyway Barton's suggestion are going to be followed.

The first thing needed to do to use the graph is define an ESR value. This value is a personal choice of the engineer, and the value is taken from Table 10. For the case of study a value between 1 and 1,6 is expected. Calculations are made with 1,2.

Table 10. Ratings of the Excavation Support Ratio (ESR) (Barton et al., 1974)

Type or Use of Underground Opening	ESR
Temporary mine openings	3,5
Vertical shafts, rectangular and circular respectively	2 - 2,5
Water tunnels, permanent mine openings, adits, drifts	1,6
Storage caverns, road tunnels with little traffic, access tunnels, etc.	1,3
Power stations, road and railway tunnels with heavy traffic, civil defence shelters, etc.	1,0
Nuclear power plants, railroad stations, sport arenas, etc.	0,8

For a 30 m<sup>2</sup> section the span is about 6 metres. The equivalent dimension to use Barton classification will be:

$$\text{Equivalent Dimension (m)} = \frac{\sqrt{\frac{\text{Tunnel Section (m}^2\text{)}}{\pi}}}{ESR}$$

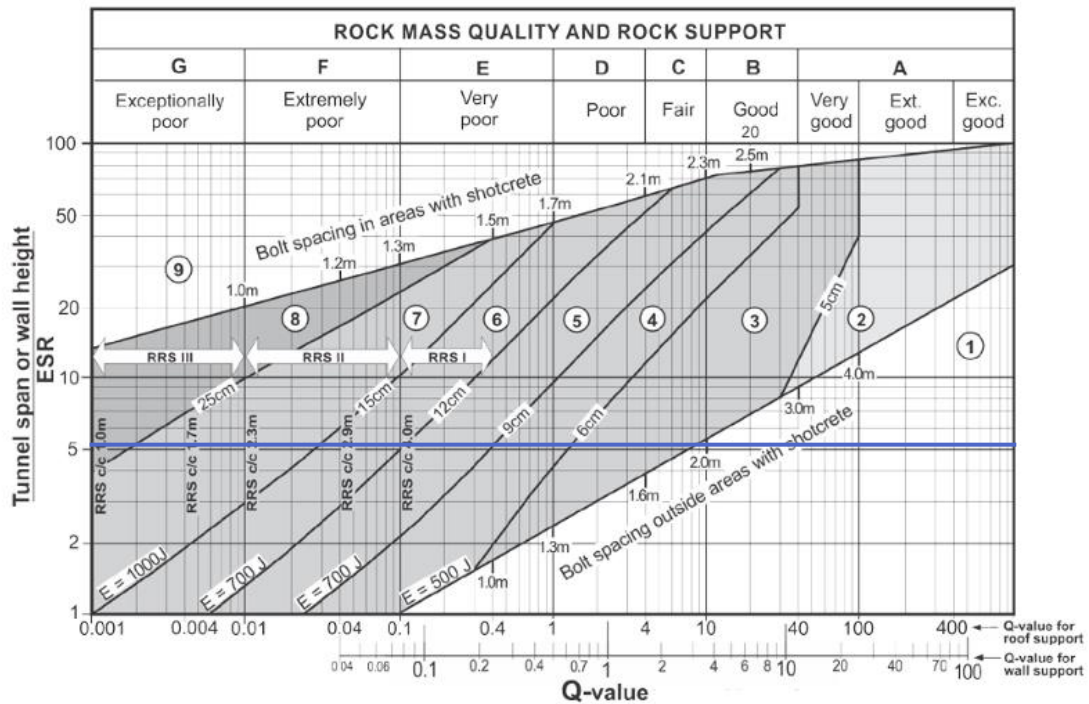

Figure 48. Supporting Per Barton's Q Classification (Norwegian Geotechnical Institute, 2014)

Barton's initial selection is taking into account very optimistic shotcrete values. In order to be more pragmatic and having in mind that a regular pass is around 5 cm of shotcrete, then the following values are obtained.

Table 11. Shotcrete Necessities of the Excavation

Q		Shotcrete [cm]
0	0,01	25
0,01	0,1	20
0,1	1	15
1	4	12
4	10	10
10	40	5
40	100	5
100	400	0
400	1.000	0

Known the thickness of the shotcrete layer it is possible to calculate the amount of concrete needed for a pass. It is calculated on the following way:

$$\text{Concrete Needed (m}^3\text{)} = \text{Layer Thickness (m)} \cdot \text{Advance Length (m)} \cdot \frac{2}{3} \text{Tunnel Perimeter (m)}$$

Once the amount of concrete is known, the shotcrete time can be calculated as

$$\text{Shotcrete Time (h)} = \frac{\text{Shotcrete Section (m}^3\text{)}}{\text{Application Performance (}\frac{\text{m}^3}{\text{h}}\text{)}} \cdot (1 + \text{Rebound}(\%))$$

In this point is needed to define the shotcrete application performance and the shotcrete rebound value.

- Application Performance: its value depends on the shotcrete machine but values between 15 and 20  $\frac{\text{m}^3}{\text{h}}$  have been considered. The calculation has been done with a value of 17,5  $\frac{\text{m}^3}{\text{h}}$ .
- Rebound: on shotcrete application rebound is an important parameter. Not all the shotcrete applied is going to be fixed on the walls, an important amount of it is going to be lost, and its value depends, in a very important way, on the skills of the shotcrete machine operator. The rebound values considered are between 20 and 25%.

The application time for shotcrete in this study is shown in Table 12.

Table 12. Shotcrete Application Timing

Q		Shotcrete [h]
0	0,01	0,77
0,01	0,1	0,61
0,1	1	0,46
1	4	0,37
4	10	0,31
10	40	0,15
40	100	0,15
100	400	0,00
400	1.000	0,00

In this point is important to talk about over excavation. It was defined previously in this document but it has a big importance over the amount of concrete needed. In civil works, the excavating company must deliver a tunnel section according the project. If over-excavation is produced, the gap between the excavated and the delivered section must be

filled with concrete and that cost must be also considered on the planning stage of the project.

To calculate the timing of the rockbolt installation is needed to know, at first, the total number of rockbolts there are going to be needed. This number will be calculated as

$$Rockbolt\ Number = \frac{2}{3} \cdot Perimeter(m) \cdot \frac{Advance\ (m)}{Spacing\ (m)^2}$$

It is considered that a square pattern of rockbolt spacing is used. The rockbolt length is obtained from Barton’s classification, Figure 48, and the results are shown in the following table.

Table 13. Number of Rockbolts and Borehole Drilling Length

Q		Boreholes	Length [m]
0	0,01	44	1,5
0,01	0,1	44	1,9
0,1	1	23	2,1
1	4	15	2,3
4	10	10	2,5
10	40	7	2,6
40	100	6	2,8
100	400	5	3
400	1.000	4	3,2

Known the number of rockbolts needed and the needed drilling length to place every rockbolt, the next stage is to find out the timing of the whole operation. This is possible in the next way:

$$Timing\ (min) = \frac{\frac{Rockbolt\ N^{er} \cdot Drilling\ Length\ (m)}{Drilling\ Rate\ \left(\frac{m}{min}\right)} + Rockbolt\ N^{er} \cdot Positioning\ Time}{Number\ of\ Booms} + Rockbolt\ Time$$

At the same as in the drilling stage, positioning time is 1 minute per borehole and the timing of placing a rockbolt is a minute. Timing is shown in Table 14.

Table 14. Supporting Requirements

Q		Shotcrete [cm]	Rockbolts Time [min]	Steel Sets
0	0,01	25	158,4	Yes
0,01	0,1	20	167	Yes
0,1	1	15	90,2	Yes
1	4	12	60,9	No
4	10	10	42,2	No
10	40	5	30,4	No
40	100	5	27,2	No
100	400	0	23,7	No
400	1.000	0	20,5	No

For the placement of the steel sets a fixed time of 90 minutes (Professor Benardos, [2019](#)) is going to be considered for all the scenarios.

Calculated the timing of the process it is time to calculate the costs. Starting again with shotcrete, the price is a variable that depends on the country and the conditions of the working. The price for a civil working scenario with their own concrete plant is going to be different from, for example, a small mine which needs to buy the concrete. Anyway, the price will be varying between 50 and 60 € per cubic meter (Professor Benardos, [2019](#)), being the value considered in this document of 50 € per cubic meter. Shotcrete application is considered both in the crown and the drift walls.

For the rockbolts the cost will be calculated as the sum of the drilling cost of the boreholes (same methodology and costs than drilling but only one boom) and the unit price of the rockbolts. This cost depends on the length of the rockbolt, being the values used the ones shown on Table 15. The cost of drilling the boreholes is calculated in the same way that the blasting blastholes.

Table 15. Rock-Bolts Cost

Q		Rock-Bolts Cost
0	0,01	15
0,01	0,1	15
0,1	1	16
1	4	17
4	10	18
10	40	20
40	100	21
100	400	22
400	1.000	23

For the steel sets was considered a cost of 20 € per meter.

Staff for supporting operation will be consider driller and roughneck and mining rig, for operations, jumbo for rock bolting and shotcrete machine for the shotcrete layer.

*5.1.2.1. Model Outputs*

With all the data, it is possible to obtain as an output two charts as the one are going to be showed below, one Gantt diagram of the excavation timing which will allow the engineers to organise the workings and one graphical representation of the excavation cost per every excavation pass.

Just before to show the charts is important to describe the characteristics the model has been ran with. This is 30 square meters' section and a length of 2.500 meters. The characteristic of the rock mass is one of the parameters that is necessary to change afterwards but just for show the outputs, good properties and a Barton's Q value of 25 is going to be supposed.

At first, Gantt diagram, Figure 49, is shown. On it is possible to see on a graphical mode, the timing of the operations supposing the start of the journey at 08:00 a.m. Things such the displacement of staff and machines to the excavation face were not considered.

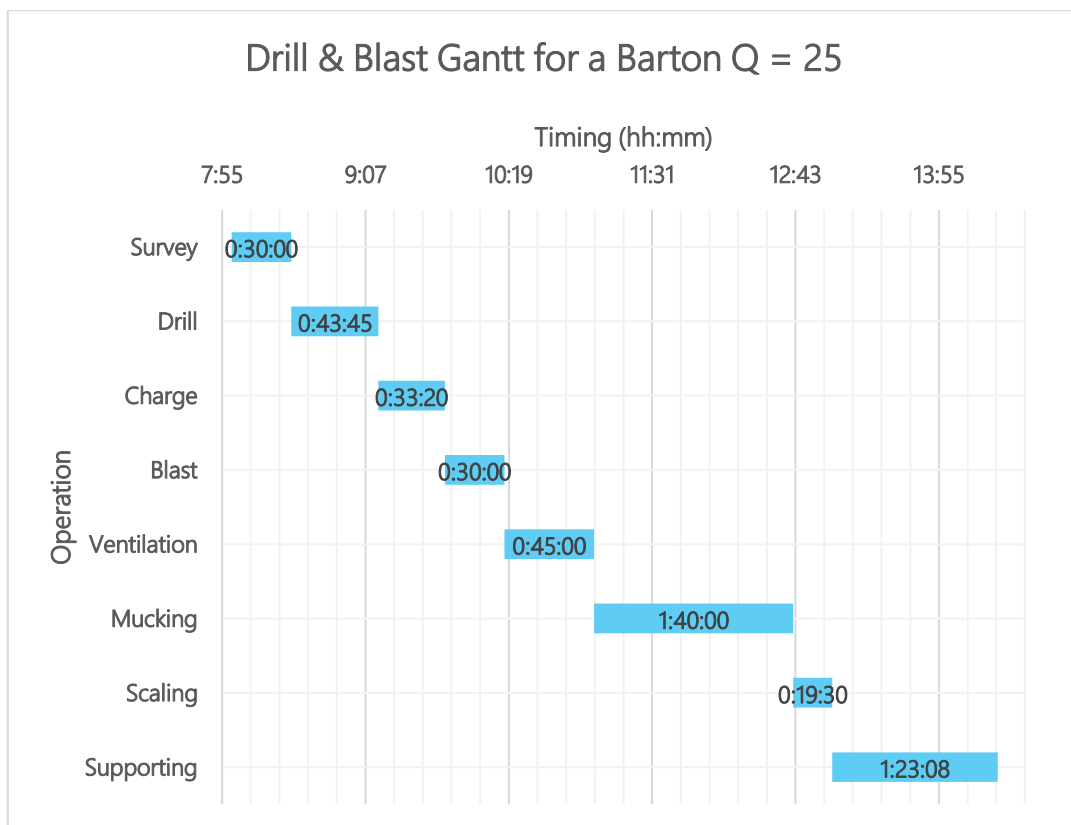

Figure 49. Drill and Blast Gantt for Barton's Q Value = 25

This kind of diagrams allow to identify the activities with a bigger consumption of time and to act in consequence in order to improve the process. Regarding the diagram, for a good rock mass on the Barton classification mucking is the activity which takes a largest timing so it will be the first activity to work on to improve the production timing of the process.

Regarding this thesis, the variation of the timing and the cost with the Q value is the main point of the study, so a graphical output of this information is interesting for the objectives proposed. Figure 50 shows the timing distribution for every process of the production cycle over the different Barton values.

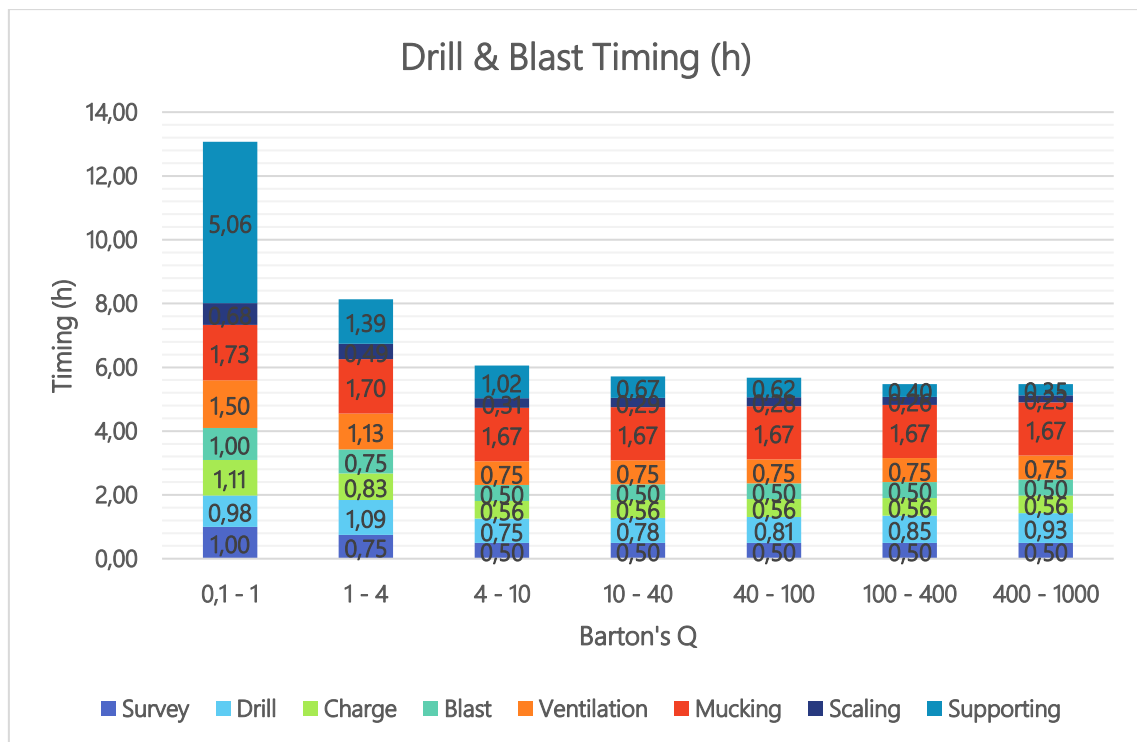

Figure 50. D&B Timing Variation over Q changes

The timing for the worst Q values are not represented because drill and blast is not applicable in terrains where is impossible to keep the blastholes open to charge the explosive.

From the data to conclusions are easy to take. Supporting is the activity which determines in a larger way the timing of the whole process as long as the timing of the other parts of the production cycle remain more or less constant. The other activity which variation is important to consider is drilling, which timing increases for the higher value of Barton's Q.

It is also necessary to have a graphical view of the operation costs, Figure 51 shows the cost for the same case as Figure 49, for a rock mass considered as good in the Barton scale. The difference on the values for the low Q values are due to the segmentation of the advance. The timing is considered for the same advance meters.

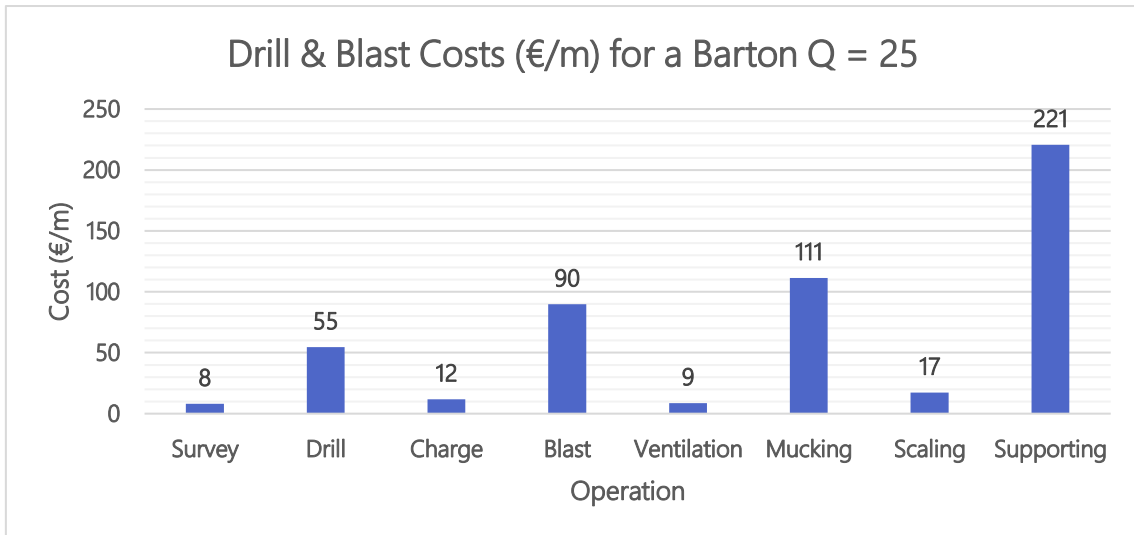

Figure 51. Drill and Blast Costs for Barton's Q value = 25

This kind of charts allow to identify the operations with a bigger cost, relate this cost with the timing of the operation and act in consequence to improve the production cycle and the timing and economic performance of the excavation.

The same as with the timing, the objective of this thesis is to analyse the variation of this values with the geotechnical conditions of the rock, because of this the information of Figure 52 is the objective of this study.

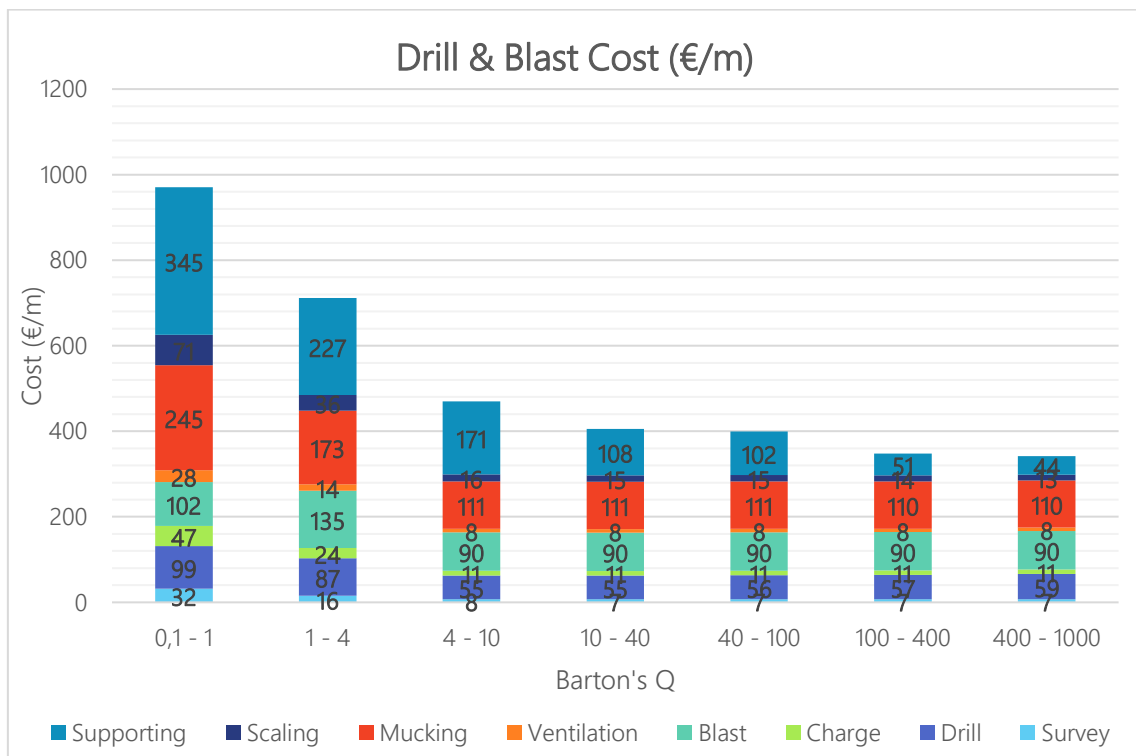

Figure 52. D&B Cost Variation over Q changes



Regarding this chart, we can confirm that the information taken from the timing analysis is fulfilled by the cost analysis. Supporting is the part of the production cycle which determines the production cycle as long the rest of the parameters remain almost constant.

### 5.1.3. Mechanical Excavation

At difference with drill and blast, mechanical excavation entails a simpler organisation of the works. The production cycle is composed for only 4 operations instead of the 8 drill and blast has. On the following pages, the data employed for the development of the model is going to be described.

In this production cycle there is not ventilation, but as it was also explained before, air must be blowing inside the tunnel all the time the workers are inside, so this cost is calculated and divided between the number of stages of the production cycle.

#### Survey

Importance of survey is already described and there is no need to talk about it again. The considered costs and timing of survey were calculated in the same way that drill and blast process.

#### Ripping

Ripping is the excavation part of the production cycle on mechanical excavation. Vibro ripper is the tool employed to excavate the ground, but vibro ripper must be attached to an excavator. The timing and cost calculation of this process will be explained.

The excavation passes within this method are supposed the same than in drill and blast due to is the supporting which restricts the advance and not the excavation method. First step is to calculate the cubic meters needed to excavate on every pass, it will be the length of the pass multiplied by the section of excavation.

For the calculation of the timing is needed to know the performance of the vibro ripper for what some data about the use of vibro ripper on the bauxite mining in Greece (ΛΑΙΟΣ, [2019](#)) and some information about impact hammers at Istanbul metro construction (Bilgin et al., [2002](#)) has been consulted. To relate all the information was a difficult process, one of the reasons is that mining performances use to be lower than in civil works because of the strict timing on this kind of excavation. Most of the information has been taken for the Istanbul metro (Figure 53), but this is data for the use of impact hammers that must be converted in data for vibro ripper.

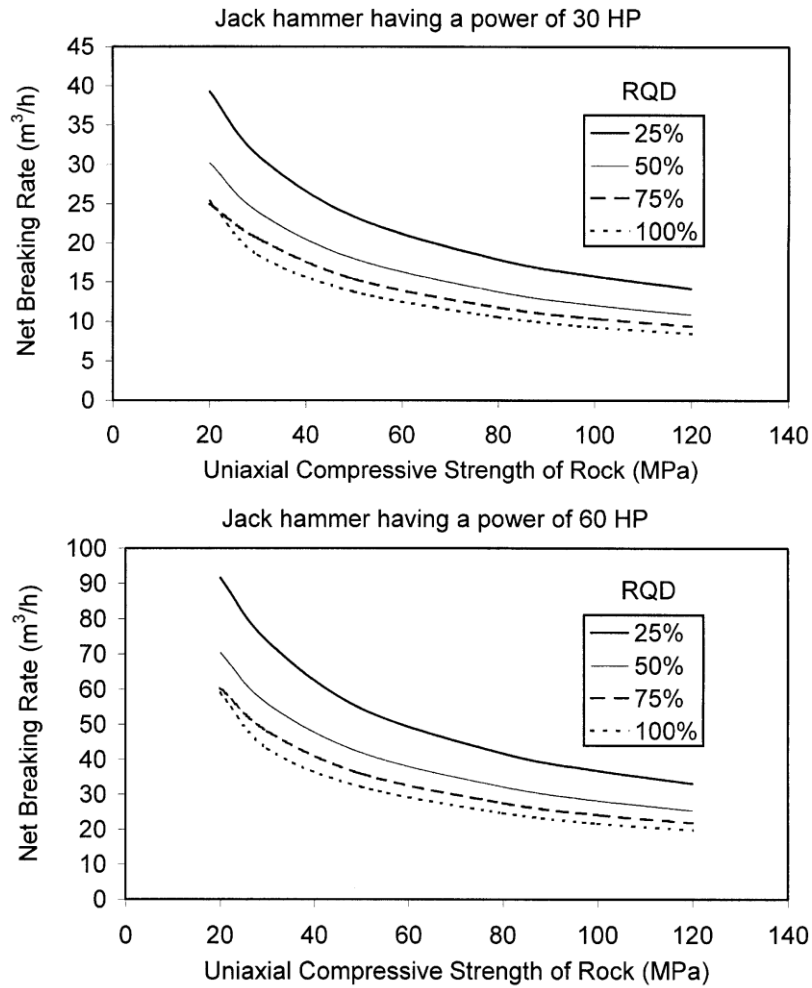

Figure 53. Impact Hammer Performance on Istanbul Metro (Bilgin et al., 2002)

It was decided to use a mean value for the data on Figure 53, what it means to consider a jack hammer of 45 horsepower. With the help from the information given by the XR company (Figure 34) an approximate extrapolation of the performance of this attachment has been made and is shown on Table 16.

Table 16. Vibro Ripper Performance

Q		[m3/h]
0	0,01	82,15
0,01	0,1	64,06
0,1	1	45,98
1	4	36,04
4	10	26,11
10	40	19,73
40	100	13,36
100	400	10,49
400	1.000	7,63

Once the performance is known, it is possible to calculate the timing dividing the total number of cubic meters of the pass by the excavation performance, calculated in the previous table.

$$\text{Ripping Time} = \frac{\text{Section (m}^2\text{)} \cdot \text{Pass length (m)}}{\text{Excavation Performance} \left(\frac{\text{m}^3}{\text{h}}\right)}$$

For the costs, it is important to consider the cost of the excavator and its operator, which have been defined previously and is also needed to consider the price of the vibro ripper attachment. Prices has been given by the XR company (XCENTRIC RIPPER, [2019](#)) so the full cost of the attachment will be considered for the whole excavation.

### Mucking

In this type of excavation, mucking can be made simultaneously with excavation. This means the mucking timing is not going to be the total mucking time. For this work a 30 % of the needed mucking time is considered.

Mucking time was calculated in the exact same way as in the D&B mucking section in this work.

### Supporting

For supporting it has been considered the same methodology than in the drill and blast method. The difference between them is the affectation to the rock mass. The use of explosives produce a bigger affectation over the country rock, being necessary the use of a heavier supporting, but this affectation doesn't take place using vibro ripper technology or is lower. The solution was to apply a factor of affectation to the rock mass to reduce the need of supporting for this method. An affectation of a 5% lower will be considered.

#### 5.1.3.1. Model Outputs

As the same it has been done with drill and blast, a graphical representation of the results for the mechanical excavation method with the same considerations was obtained. The timing of the process, Figure 54 shows that the operation with bigger time consumption is ripping and mucking. This is due to this to operations constitute the main part of the production cycle under this method.

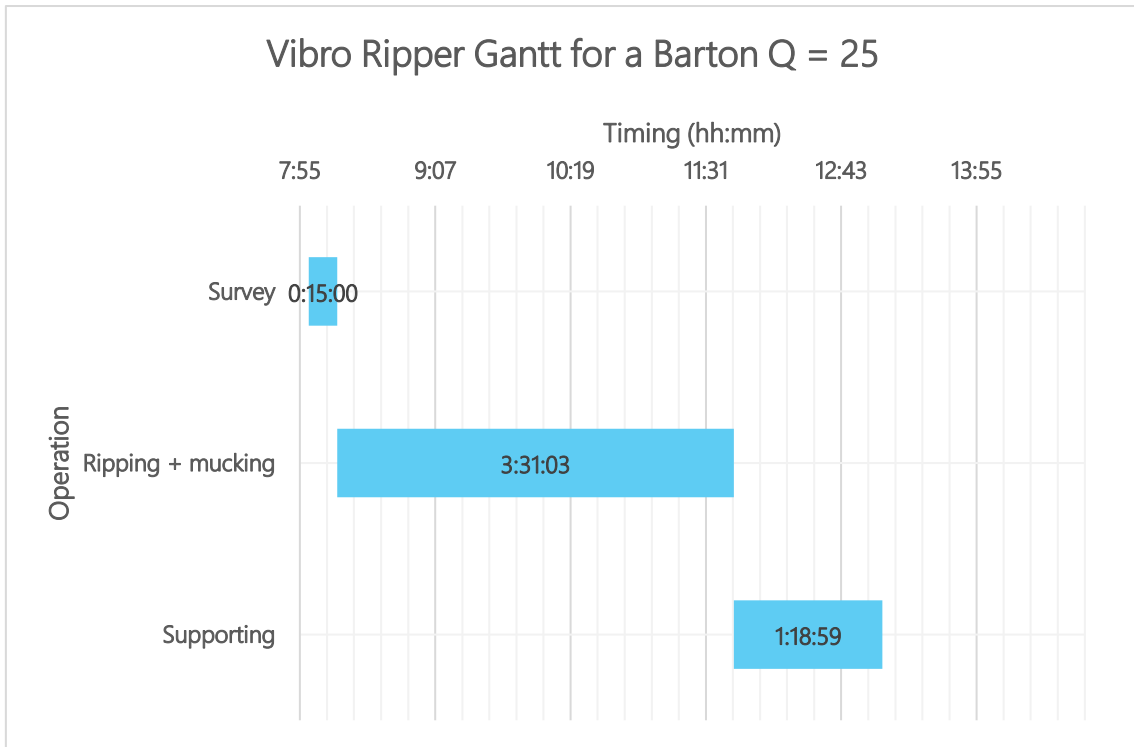

Figure 54. Mechanical Excavation Gantt for Barton's Q = 25

To know the variation of the timing for the whole range of geotechnical values, is needed to represent the timing of every process of the production cycle for every value of the Barton scale.

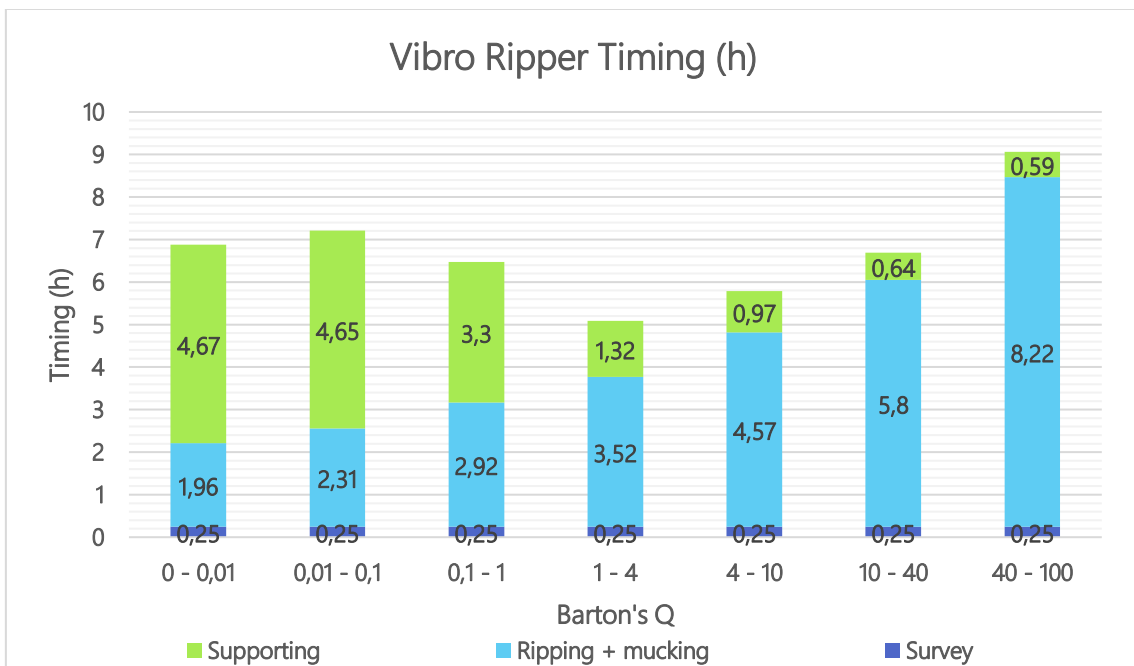

Figure 55. Vibro Ripper Timing Variation over Q changes

This chart shows interesting information for the knowledge of this process. The first point of this is that ripping + mucking timing increases with the increase on the geotechnical properties of the rock. This is due to the drop on the performance on the vibro ripper showed in Table 16. The other point is the timing of supporting. As it is expected, supporting time is bigger for worst quality rock masses because their bigger need of supporting. Due to all this, the excavation timing reaches a minimum value for bad quality rock masses and increase for elevated Barton values due to the drop on performance and to low Barton values due to supporting requirements.

In Figure 56 the costs relative to the timing shown on Figure 54 can be studied.

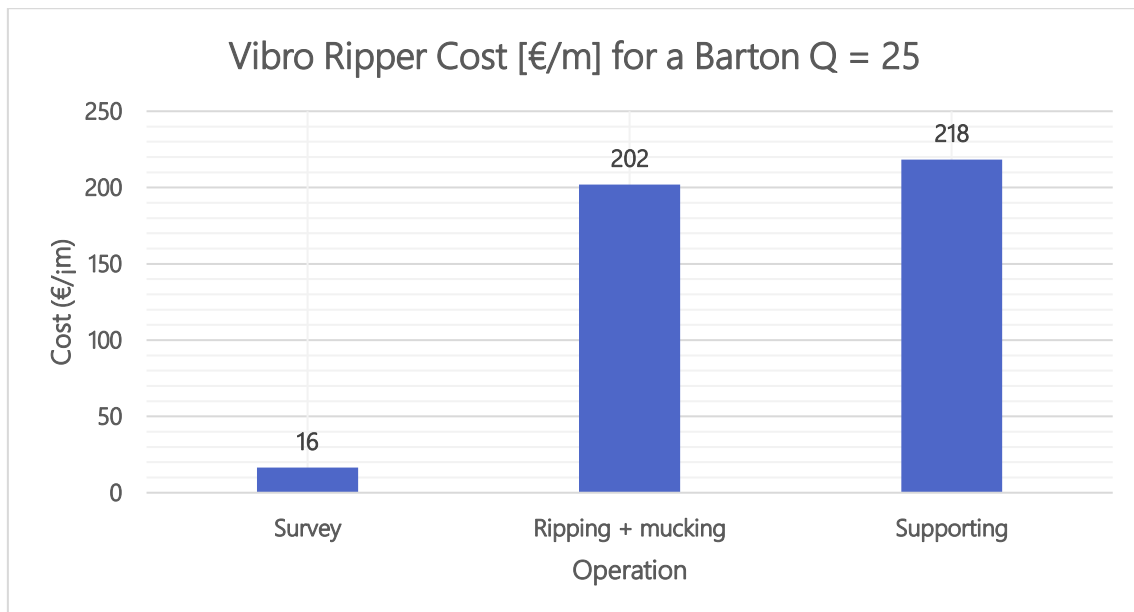

Figure 56 Mechanical Excavation Costs for Barton's Q = 25

As it was expected, ripping and mucking is the operation with a bigger consumption, but it is time to study its variation for the geotechnical properties on the Barton scale. This study is shown on Figure 57.

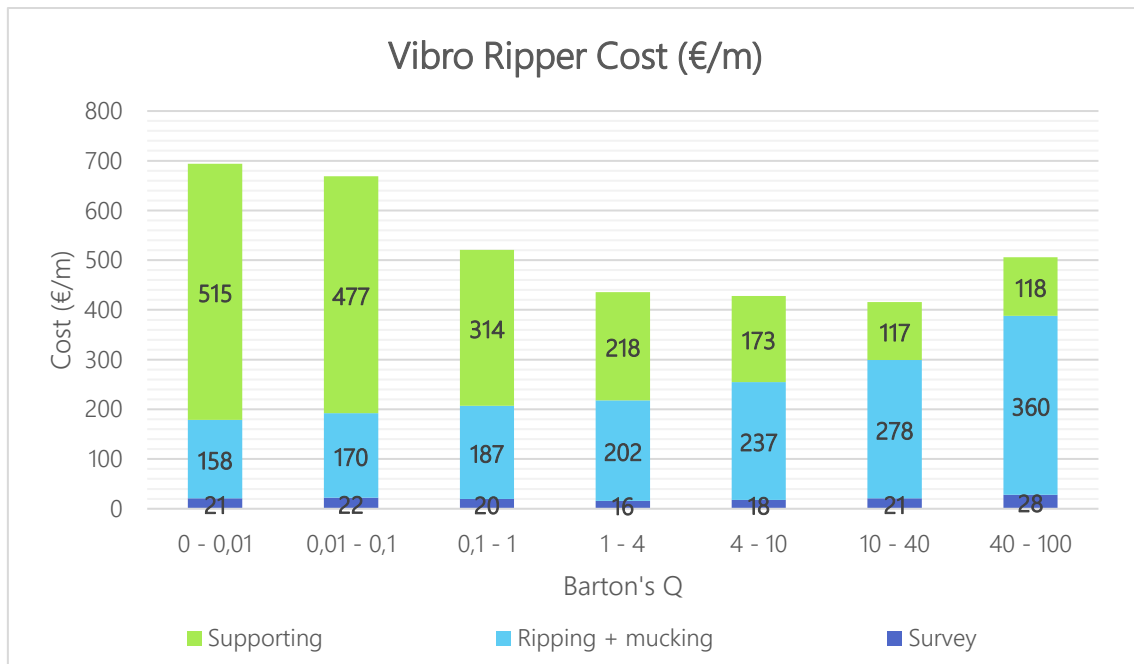

Figure 57. Vibro Ripper Cost Variation over Q changes

The outputs correspond with the timing considerations, where the minimum cost value is reached for bad to good quality rock masses.

## 5.2. Analysis

### 5.2.1. Start Point Analysis

Once the Excel file is prepared, the analysis can take place. Cost and timing evolution with Barton's Q value is well known so the next step is to compare both methods. The output data provided has proved to be reasonably acceptable, so it is time to cross the information and study the results. Theoretically drill and blast is expected to be the most suitable method for good quality rock masses and mechanical excavation for bad quality ones. In Figure 58 cost information of both methods can be studied.

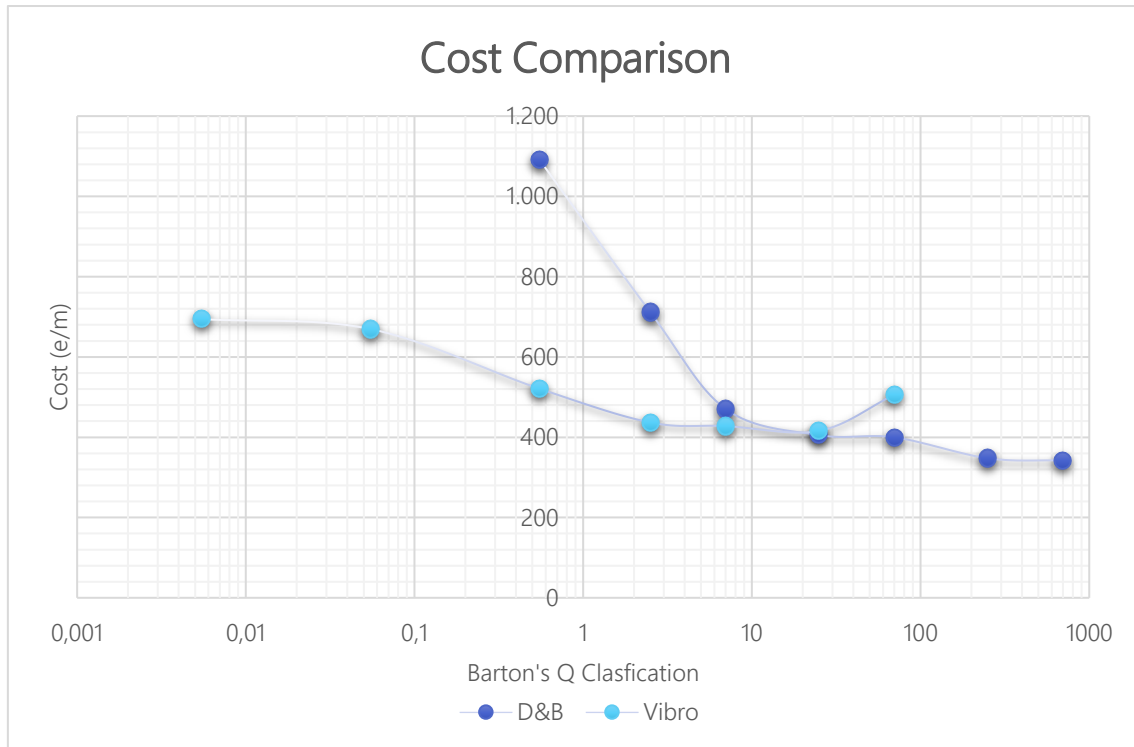

Figure 58. Cost Comparison between Drill and Blast and Mechanical Excavation

Effectively, regarding the graph, the results adapt perfectly to what is expected according to the theory. The tipping point is in good quality rock masses on Barton's scale or between medium and good quality, which means when the rocks start to be fractured, mechanical excavation takes advantage over drill and blast. This is due to the good performances of vibro ripper technology and the less affectation over the rock mass.

The high cost values for the drill and blast method in the low Q values are due to several passes are needed to reach the same advance. The results shown are for the same advance distance.

For having the complete image of what happens let's going to analyse the evolution of the timing of both processes studying the graph on Figure 59.

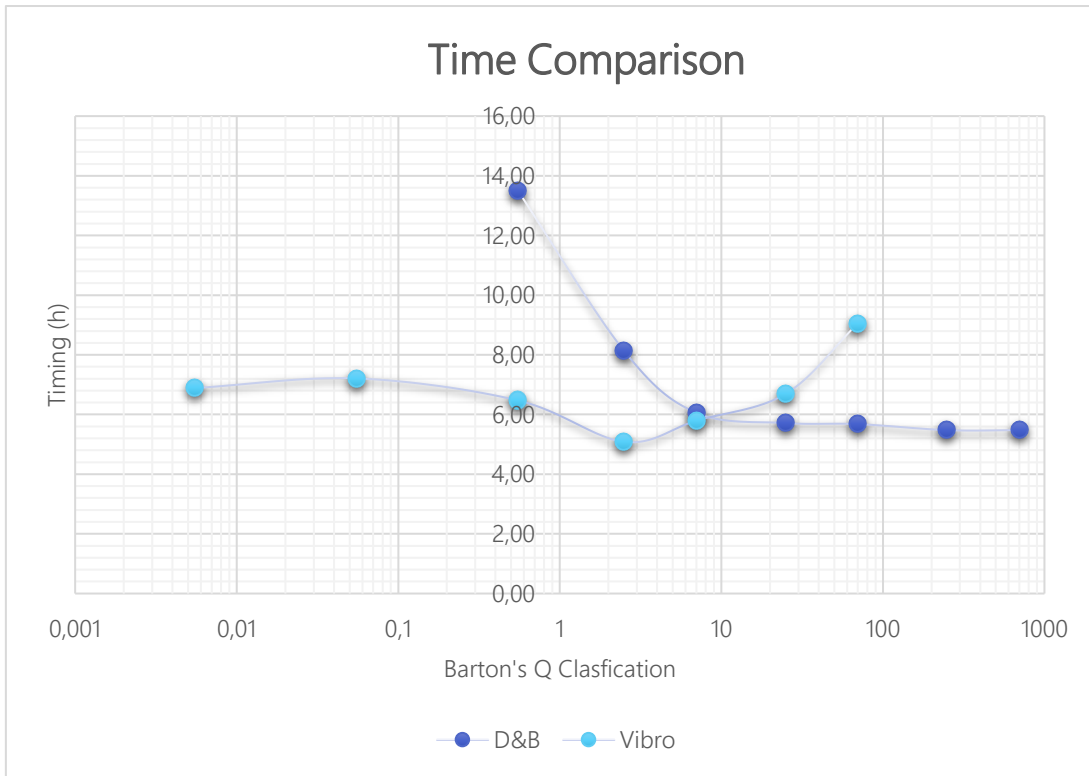

Figure 59. Time Comparison between Drill and Blast and Mechanical Excavation

The graph shows the point where the two methodologies cut is almost the same tan in the cost analysis. In this case medium rock quality on Barton 's scale is the tipping point, this means, there is almost no limiting factor for the selection of one or another method. So, both, for timing and costs, mechanical excavation is most suitable in rock masses beneath medium quality on Barton's scale and drill and blast over very good quality. For the determination of what happens in the middle deeper analysis is needed.

### 5.2.2. Section Variation Analysis

One interesting analysis is the study of what happens when the excavation section is modified. This analysis is made and show on Figure 60 with the objective to identify how the excavation costs vary with the variation of tunnel section.



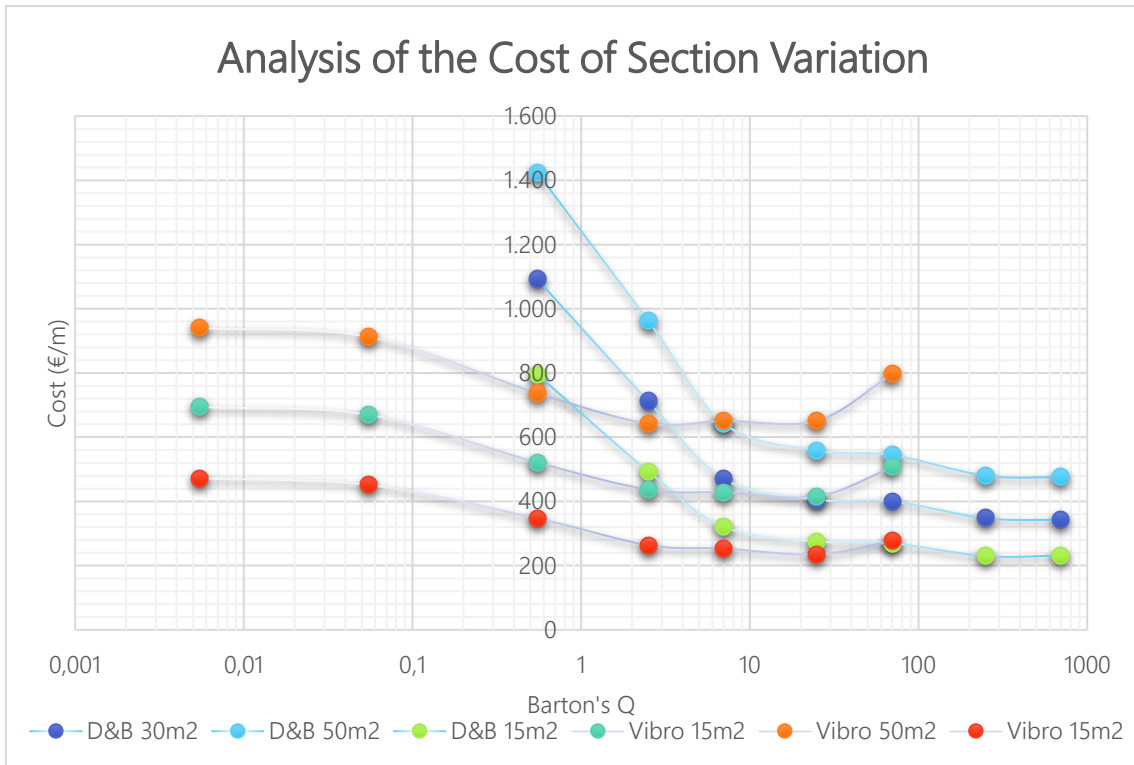

Figure 60. Cost Analysis of Section Variation

Regarding the graph, as the section increases, vibro ripper method is less competitive against the drill and blast method. This is easily explained with the ripping time. Bigger is the section bigger is the time needed to excavate the whole section. In the other side, drill and blast method requires a bigger number of blastholes but the drilling time is lower than the excavating time.

Is important so, to take in consideration the section of the tunnel over the selection of the excavation method.

### 5.2.3. Length Variation Analysis

It was also studied what happens when the excavation length varies. 3 cases have been studied and the results are shown in Figure 61.

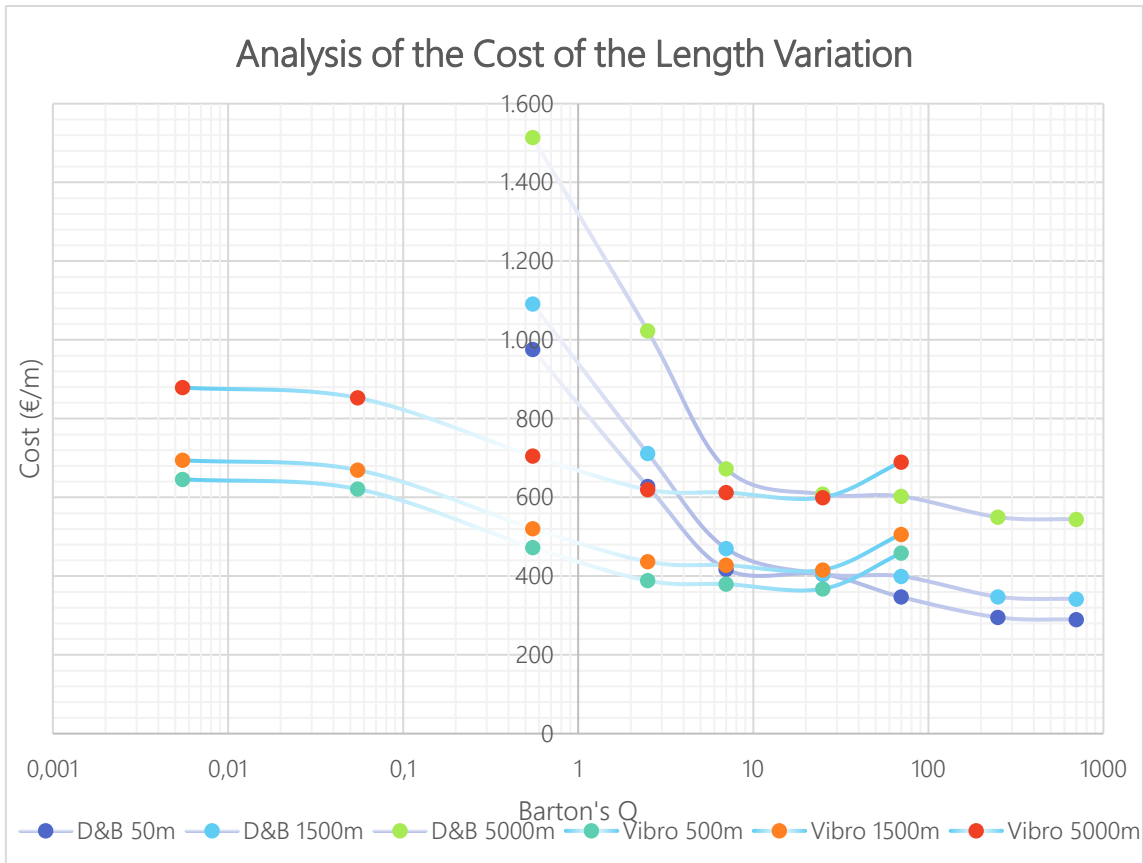

Figure 61. Cost Comparison for Different Tunnel Lengths

The results show that the cutting point between both methods shown almost no variation according to the tunnel length. This is due the variation on the timing for both methods is in the same grade, so the results remain similar.

#### 5.2.4. Monte Carlo Simulation

To deal with uncertainty is interesting to bring forward some statistical analysis of the data as it is the Monte Carlo method. This method provides approximate solutions to a wide variety of problems. In this study, Monte Carlo simulation is going to be used to study the cutting point between drill and blast and mechanical excavation. The most variable parameter is the performance of the vibro ripper in excavation so this is the parameter subject of study.

As the cutting point is between very good and good values on the Barton's scale, these two points are going to be deeply studied. As it was explained previously data for vibro ripper is taken from Istanbul metro and a mean value is being used for the values on Figure 53. For this analysis a triangular distribution is going to be used being the extreme values the performance for 30 and 60 HP and the most probable value its mean. This is shown on Figure 62.

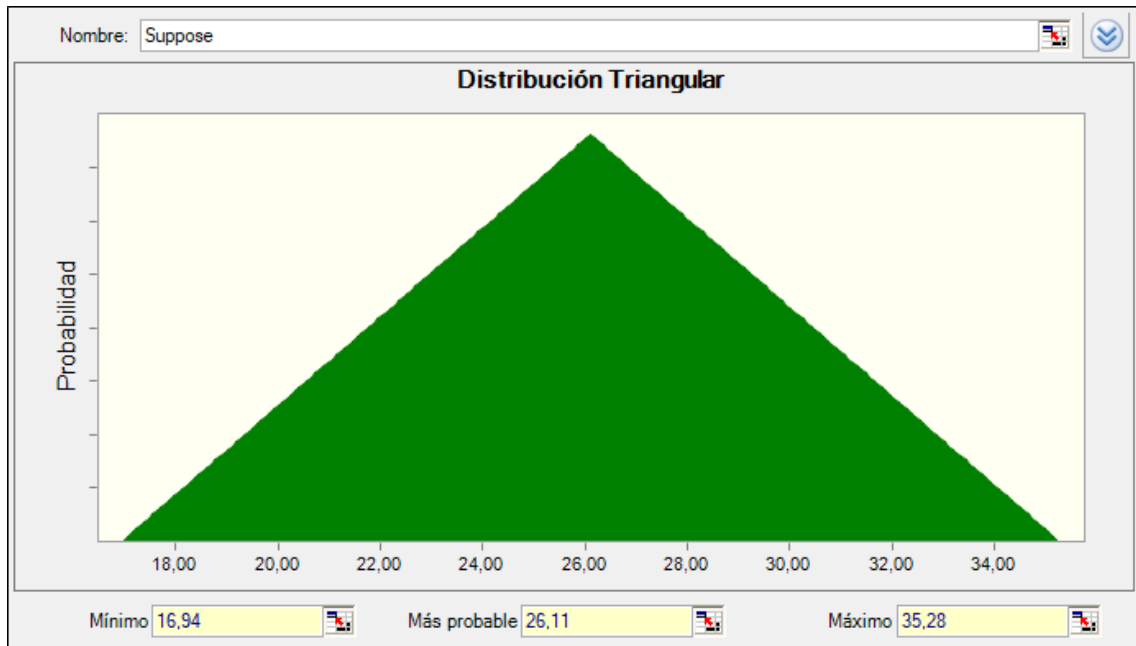

Figure 62. Triangular Distribution for a Barton  $Q = 7$

The Monte Carlo simulation is prepared to use this value to calculate the ripping timing in hour/pass defined previously. After 1.000 iterations, the results reached for the ripping time are shown on Figure 63.

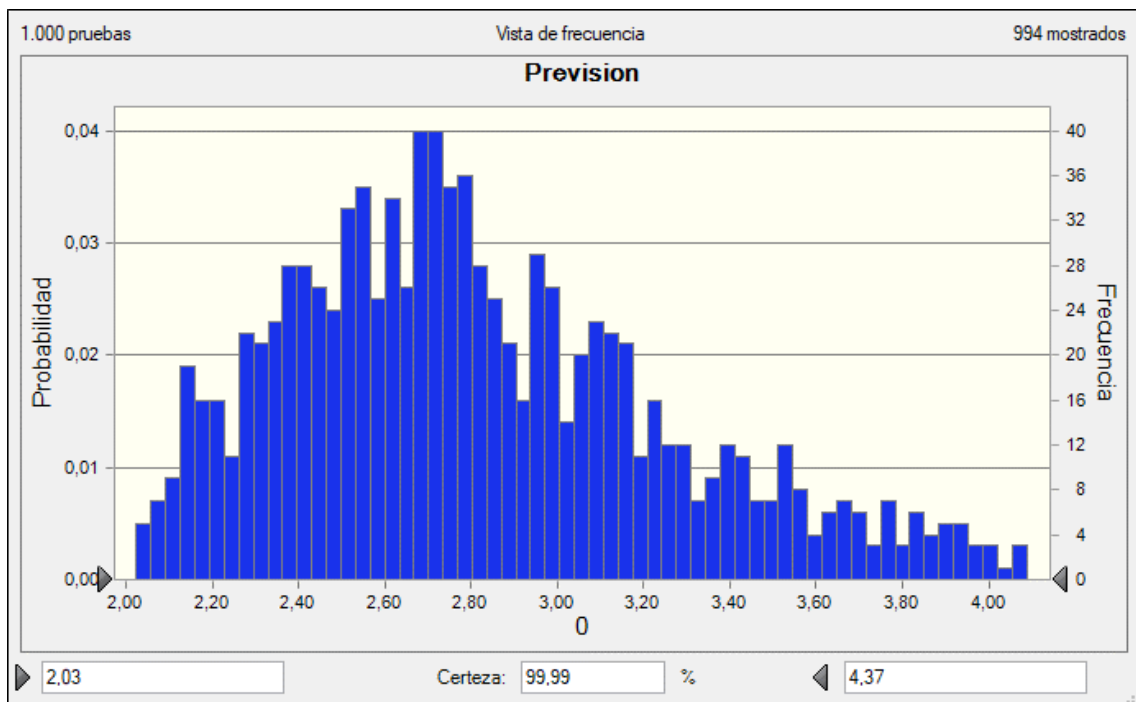

Figure 63. Ripping Time from Monte Carlo Simulation for  $Q = 7$

This process is repeated for the values near the cutting point in the cost comparison, shown on Figure 58. Once the timing is known, that time is used to calculate the cost within each point for, at the end plot the maximum and minimum value for the vibro ripper costs.

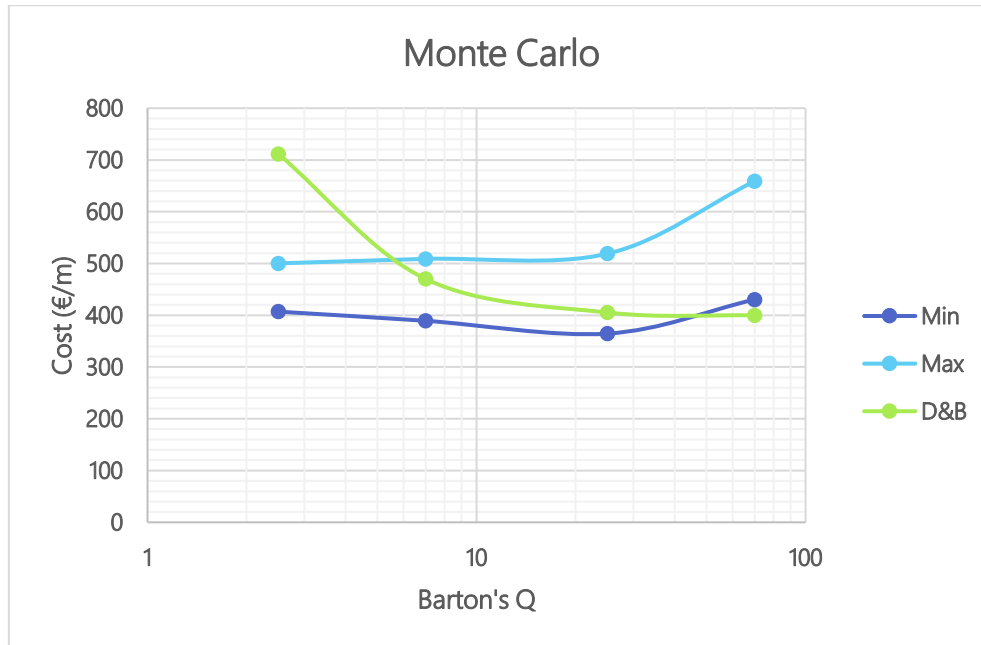

Figure 64. Monte Carlo Results

From this chart, with the criteria used on the Monte Carlo simulation is possible to say that, considering the variation of the performance of the vibro ripper, the cutting point is between 6 and 50 on Barton scale. This displaces the cutting point which will be between medium and very good properties.

The conclusion with this analysis is that over values of 50 on Barton scale D&B is the most suitable method, and below 6 vibro ripper is the preferred one. For rock masses in the middle of this values deeper analysis is needed.

## 6. Conclusions

Finished the study made on this thesis, there are some valuations there are needed to make about the study process, but at first place is interesting to explain the things learnt during this process.

One of that things is how to organise the work. Before any calculation is important to think which are the expected results. Having an idea of what is expected makes easier to analyse the outputs of any model made and find mistakes that can turn off the whole model. If the model confirms the expectations it means the model is good, if not, deeper analysis is needed.

There are simple analysis in the initial steps of any project which can help to gain understanding about which parameters are most important or its variations are going to affect bigger the model. Identification of that parameters can help to reduce timing, cost or both.

Knowledge of the production cycle is imperative. It is not possible to analyse any excavation with no idea of the excavation methods or the constitution of the production cycle. It's the engineer's job to have this knowledge and be aware of the advance in technique to apply it the best as possible.

Timing planning is key in any engineering work, but there is no need of specific managing software or knowledge. To build a time diagram (Gantt type) as the ones showed in this paper, Figure 49 for example, takes no time and help to identify which parts of the process have a bigger time consumption. The same happens with the cost.

To have timing and cost information is mandatory to a good resource management, there is no need of a big knowledge but graphical outputs are helpful to comprehend the mechanisms behind the process.

Is interesting to relate all the parameters. To have an Excel file (or any other software) where the different parameters influencing the excavation are expressed as a function of the others will allow the analysis of not one scenario if not to study how the variations on every parameter influence the excavation.

It is now time to go to the conclusions of the study.

- There is no an exact solution but a range of possible values

Earth sciences are empirical while all the other sciences are theoretical, this is the main point to consider on excavation. There are laws that govern the behaviour of the rock masses, but the uncertainty doesn't allow the study the rock mass in its totality, and forces to use empirical methods and made suppositions that need to be confirmed.

- Data is terribly difficult to obtain

In every excavation, the particular characteristics of the rock masses are going to make the analysis unique. There are not two equal excavations. Because of this data is unique in every excavation, performance, wear rate, support requirements and every other parameter to consider is also unique. In this study, ranges of values known to be true have been used. Every excavation will produce its own data.

- No vibration data

Because data is unique in every excavation is not possible to realise the study of one of the most important parameters when comparing both methods which is the vibrations induced over nearby structures. Vibration is one of the parameters which further restrains the use of drill and blast method, so its study would be interesting.

- Study depends on an elevated number of parameters and every small variation in any parameter can change significantly the results of the study

Variations on different parameters as the abrasivity (wear rate), joints number or orientation (support requirements) or any other produce big variations on timing and costs of the process, so to have an idea of how these variations can affect the excavation and be prepared is what differentiates a good engineer.

For the results obtained in this study:

- The results are not completely the expected. It was expected the point where both method collide will be in lower Q values on Barton's scale.

This could be explained by the variability of the data. After Monte Carlo study the minimum values could adapt to what it is expected with values between 4 and 10, but the maximum value is completely out of range.

One explanation for this is that the data provided for the companies about the performance of the vibro ripper is higher than the true performance. Another consideration it must be taken into account is that stops on the machinery haven't been considered, so the using hours of excavator in mechanical excavation are an important factor.

- According with the results, vibro ripper is a technology which must be seriously considered in the future.

The results, even if there is certain variability on the data, shows an excavation method capable to compete against drill and blast, with bigger performances than impact hammer for a big range of rock quality values.

- D&B is a very versatile method, capable to adapt easily to changes in rock conditions or project design.

## 7. References

- Ai, Chi & Zhang, Jun & Li, Yuwei & Zeng, Jia & Yang, Xin-liang & Wang, Ji-gang. (2016). Estimation Criteria for Rock Brittleness Based on Energy Analysis During the Rupturing Process. *Rock Mechanics and Rock Engineering*. 10.1007/s00603-016-1078-x.
- Akhavan, A. (2004). The Quartz Page: Quartz as a Rock-Forming Mineral. [online] Quartzpage.de. Available at: [http://www.quartzpage.de/gen\\_rock.html](http://www.quartzpage.de/gen_rock.html)
- Anderson, J.T., Papineau, W.E., 1989. Rock excavation with boom mounted hydraulic hammers. *Foundation Engineering: Current Principles and practices: Proceedings of the Congress*, vol 1. ASCE, Evanston, IL., June 25 – 29, pp 418 – 431
- Arabi Shad, H., Sereshki, F., Ataei, M. and Karamoozian, M. (2016). Prediction of rotary drilling penetration rate in iron ore oxides using rock engineering system. Shahrood University of Technology: Department of Mining, Petroleum and Geophysics.
- Barton, N., (1988) Rock Mass Classification and Tunnel Reinforcement Selection Using the Q-System. *Rock Classification Systems for Engineering Purposes*, ASTM STP 984. Louis Kirkaldie, Ed., American Society for Testing and Materials, Philadelphia, pp 59-88.
- Barton, N., Lien, R., Lunde, J., (1974) Engineering Classification of Rock Masses for the Design of Tunnel Support. *Rock Mechanics* 6, 189-236 (1974)
- Bilgin, N., Dincer, T., Copur, H., 2002. The performance prediction of impact hammers from Schmidt hammer rebound values in Istanbul tunnel drivages. *Tunneling and Underground Space Technology* 17, 237-247.
- Cała, Marek & Geomechaniki, Katedra & I Geotechniki, Budownictwa. (2019). Norwegian Method of Tunnelling.
- Chatziangelou, M. and Christaras, B. (2019). ROCK MASS BLASTABILITY DEPENDENCE ON ROCK MASS QUALITY. Department of Civil Infrastructure Engineering, School of Technological Applications of Thessaloniki, Greece and Department of Geology, Aristotle University of Thessaloniki, Greece.
- Copur, Hanifi & Ozdemir, L & Rostami, Jamal. (1998). Roadheader applications in mining and tunneling. *Mining Engineering*. 50.
- D.U., Miller, R.P., (1966). Engineering classification and index properties for intact rock. Tech. Rep. No. AFWL-TR-65-116, Air Force Weapons Lab, Kirtland Air Force Base, Albuquerque, NM.
- Dahl F (2003) DRI, BWI, CLI standards. NTNU, Trondheim, p 20
- Dd-eng.com. (2019). Daedong Engineering Co., Ltd. [online] Available at: <http://www.dd-eng.com/new/main/main.php> [Accessed 8 Apr. 2019].
- Deere, D.U., (1963 ). Technical description of rock cores for engineering purposes. *Felsmechanik und Ingenieurgeologie*, Vol 1, No 1, pp 16-22
- Engin, I.C., Bayram, F. & Yasitli, N.E., (2013). Experimental and Statistical Evaluation of Cutting Methods in Relation to Specific Energy and Rock Properties *Rock Mech Rock Eng* (2013) 46: 755.

- Excavabilidad Mecánica de los Macizos Rocosos. (2016). [Class Notes] Universidad de Vigo, Obras Subterráneas. Vigo.
- Extraco SA - Αρχική. (2019). Retrieved from <http://www.extraco.gr/index.php>
- Franklin, J.A., Broch, E., Walton, G., (1971). Logging the mechanical character of rock. *Trans Isnt Min Metall* 80:A1-A9
- Haiqing, Yan, Da, Huang, Xiuming, Yang, Xiaoping, Zhou. (2013). Analysis model for the excavation damage zone in surrounding rock mass of circular tunnel. *Tunneling and Underground Space Technology* 35 (2013) 78-88.
- Holmberg, R, 1982. Charge calculations for tunnelling", *Underground Mining Methods Handbook*, SME, New York.
- Jimeno, C.L., Jimeno, E.L. and Carcedo, F.J.A. (1995) *Drilling and Blasting of Rocks*. Geo-Mining Technological Institute of Spain, 345-351.
- Kaliampakos, D., Benardos, A., (2008). Underground space development: setting modern strategies. *WIT Transactions on the Built Environment*, Vol 102.
- Kealeboga Segetsho, G. S., (2017) Application of Rock Mass Classification and Blastability Index for the improvement of wall control at Phoenix Mine, University of the Witwatersrand, Johannesburg.
- Lilly, P. (1986). An Empirical Method of Assessing Rock mass Blastability. The AusIMMIEAust Newman Combined Group, Large Open Pit Mining Conference. Australia. pp. 89-92.
- Macias, Javier & Dahl, Filip & Bruland, Amund & Kaesling, Heiko & Thuro, Kurosch. (2017). Drillability Assessments in Hard Rock.
- Maidl, Schmid, Ritz and Herrenknecht, (2001). Correlation of TBM cutter life [m<sup>3</sup>/disc], UCS and CAI for some common rock types.
- Nilsen, Bjørn & Dahl, Filip & Holzhauser, Jurg & Raleigh, Peter. (2006). Abrasivity of soils in TBM tunneling. *Tunnels and Tunnelling International*. 38. 36-38.
- Nord, G., & Stille, H. (1988). Bore-and-blast techniques in different types of rock: Sweden's experience. *Tunneling and Underground Space Technology*, Volume 3, Issue 1, 1988, Pages 45-50.
- Norwegian Geotechnical Institute (2014). <http://www.ngi.no/>
- Ocak, I., Bilgin, N., (2010). Comparative studies on the performance of a roadheader, impact hammer and drilling and blasting method in the excavation of metro station tunnels in Istanbul. *Tunneling and Underground Space Technology*, Volume 25, Issue 2, March 2010, Pages 181-187.
- Ocak, I., Evren Seker, S., Rostami, J., (2018). Performance prediction of impact hammer using ensemble machine learning techniques, *Tunnelling and Underground Space Technology*, 80 (2018) 269-276.
- Ozcelik, M., (2016). Criteria for the Selection of Construction Method at the Ovit Mountain Tunnel (Turkey), *KSCE Journal of Civil Engineering* (2016) 20(4): 1323-1328.
- Patel, R. (2019). What is Hydraulic Hammer and how does it work ?. [online] *Engineering Insider*. Available at: <https://engineeringinsider.org/hydraulic-hammer-working/>
- Peer, P & Vermeersch, Pierre & Paulissen, Etienne. (2002). Chert Quarrying in the Nazlet Safaha Area.



- Pelizza, S., Patrucco, M., Benedetto, G., 1974. Workplace environmental conditions and innovative tunnel driving techniques. Measurement air control. In: Proceedings of the Tunneling and Ground Conditions, Balkema, pp. 617-623
- Perras, Mathew A., and Diederichs, Mark S., (2016). Predicting excavation damage zone depths in brittle rocks. *Journal of Rock Mechanics and Geotechnical Engineering*.
- Plinninger, R.J., (2010). Hardrock abrasivity investigation using the Rock Abrasivity Index (RAI).
- Professor Benardos, A., Thesis Coordinator, National and Technical University of Athens.
- Professor García Menéndez, Julio F. Túneles e infraestructuras subterráneas (class notes), Universidad de Vigo (2019).
- Professor Martínez Torres, C., Ingeniería de Explosivos (Class notes). Universidad de Vigo (2019)
- Project Management Institute. (2004). A guide to the project management body of knowledge (PMBOK guide). Newtown Square, Pa: Project Management Institute.
- Rancourt, A. (2014). Design and Construction of shafts and hard rock TBM Tunnel for a water main in Montreal. [online] Tunnelcanada.ca. Available at: <http://www.tunnelcanada.ca/members/documents/2014/TAC2014/papers/Tac2014Paper151.pdf>.
- Skawina, B., Greberg, J., Salama, A., and Schunesson, H., Mechanical Excavation and Drilling and Blasting – A Comparison Using Discrete Event Simulation. Springer International Publishing Switzerland 2014.
- Soltys, A., Pyra, J., Winzer, J., (2018). The use of vibration monitoring to record the blasting works impact on buildings surrounding open-pit mines. *E3S Web of Conferences* 36, 02008 (2018).
- Teale, R., (1964). The concept of specific energy in rock drilling, *Int. J. Rock Mech. Mining Sci.* Vol. 2, pp. 57-73.
- Thuro, K., Plinninger, R.J. (2003). Hard rock tunnel boring, cutting, drilling and blasting: rock parameters for excavability IRSM 2003. Technology roadmap for rock mechanics, South African Institute of Mining and Metallurgy.
- Tugraz.at. (2019). IAG - Cerchar Abrasivity Index Test. [online] Available at: <https://www.tugraz.at/institute/iag/services/engineering-geological-services/cerchar-abrasivity-index-test/>.
- Tunçdemir, H., (2008). Impact hammers application in Istanbul metro tunnels. *Tunneling and underground space technology* 23. 264-272.
- Verma, H. K., Samadhiya, N. K., Singh, M. Goel, R. K., Singh, P. K., (2018). Blast induced rock mass damage around tunnels, *Tunneling and Underground Space Technology*, 71 (2018) 149-158.
- Wang Kaile, Yang Guoping, Hu Kaijun, Wang Kai, Cao Guojun. The Application Status and Prospects of Vibro Ripper. *International Journal of Energy and Power Engineering*. Vol. 3, No. 3, 2014, pp. 158-161.
- Wayment, W., Grantmyre, I., 1976. Development of high blow energy hydraulic

- Willie, B., (1985). Hydraulic Breakers, International Mining, March 1985, 18-24.
- XCENTRIC RIPPER. (2019). INICIO - XCENTRIC RIPPER. [online] Available at: <https://xcentricripper.com/es/> [Accessed 6 Apr. 2019].
- Yang, J., Lu, W., Li, P. et al (2018). Evaluation of Tock Vibration Generated in Blasting Excavation of Deep-buried Tunnels. KSCE Journal of Civil Engineering. 22:2593
- ΛΑΙΟΣ, Ν., 2009. ΕΞΟΡΥΞΗ ΥΠΟΓΕΙΩΝ ΒΩΞΙΤΙΚΩΝ ΚΟΙΤΑΣΜΑΤΩΝ ΜΕ ΥΔΡΑΥΛΙΚΗ ΣΦΥΡΑ ΥΠΟΓΕΙΩΝ (VIBER RIPPER). National and Technical University of Athens