

Διπλωματική εργασία

εκθεσιακό δίκτυο:
εκφράσεις πολιτισμού
στη Συγγρού



Ευαγγελία Παπαδουράκη

επιβλ. καθηγητής:
Δημητρης Παπαλεξόπουλος

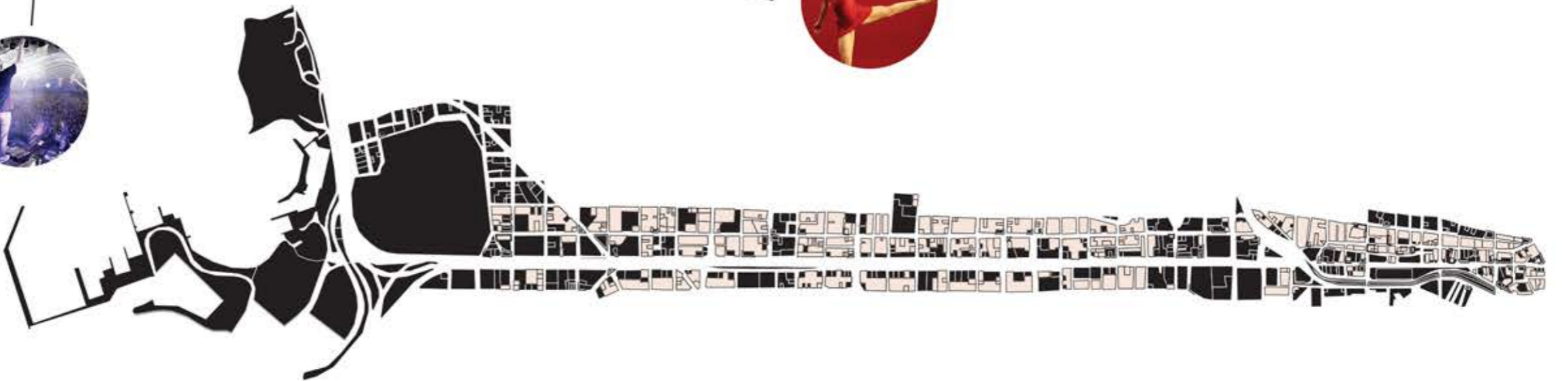
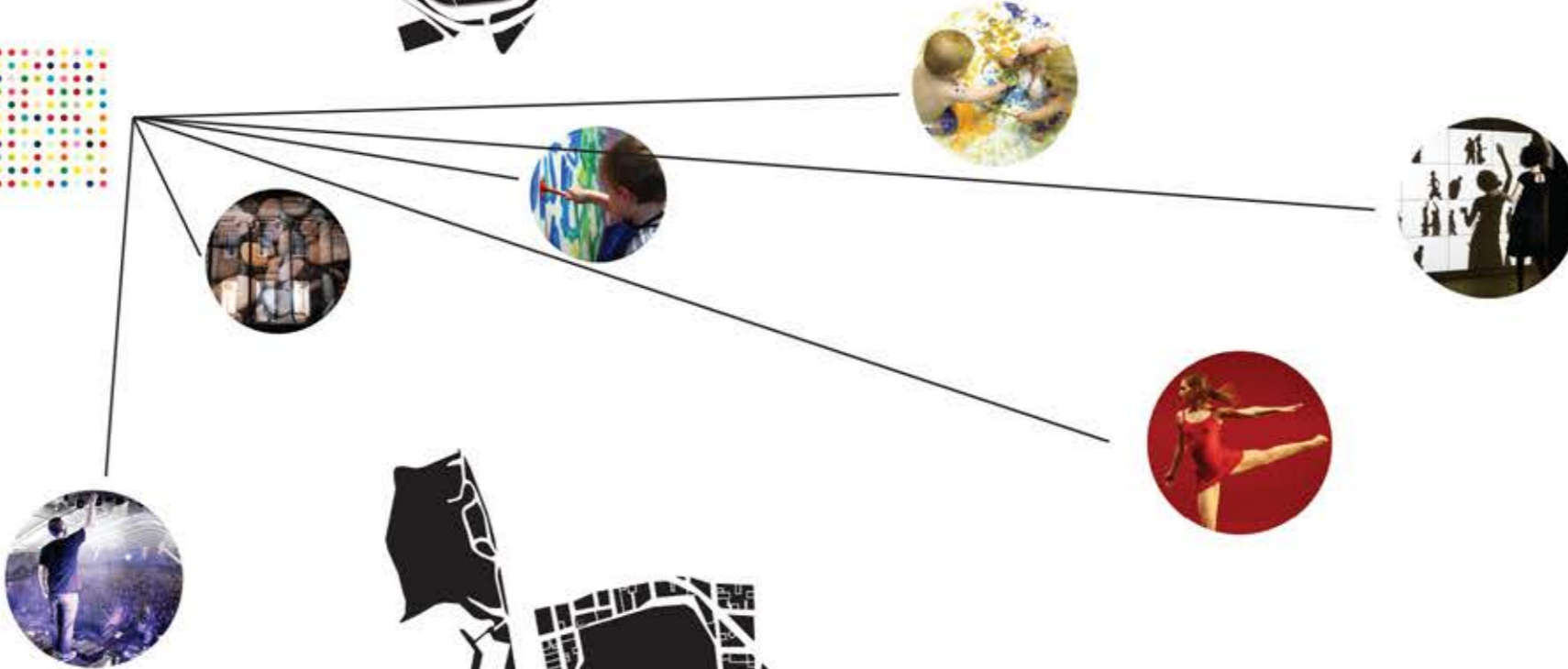
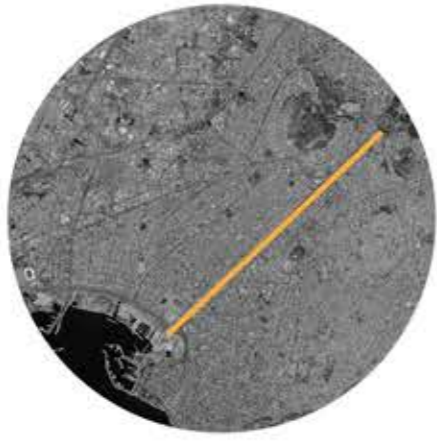

concept

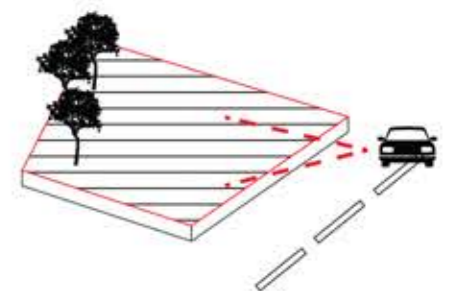
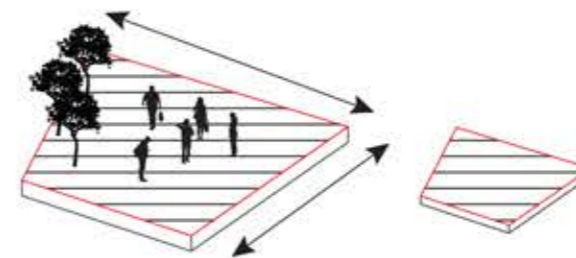
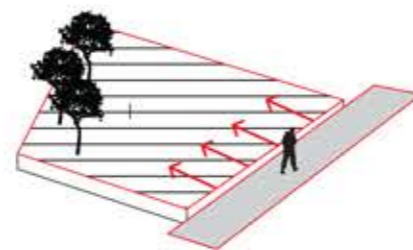
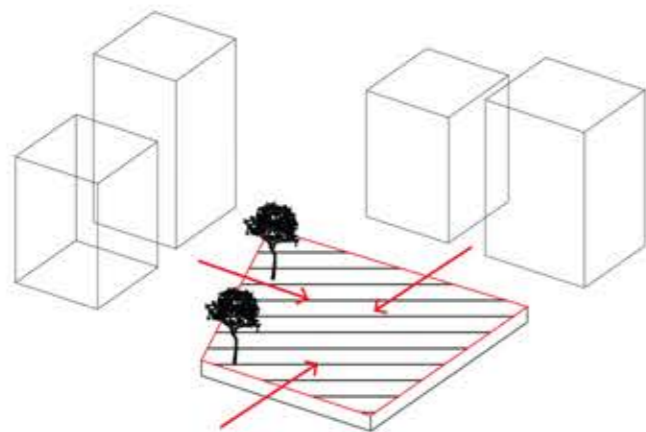
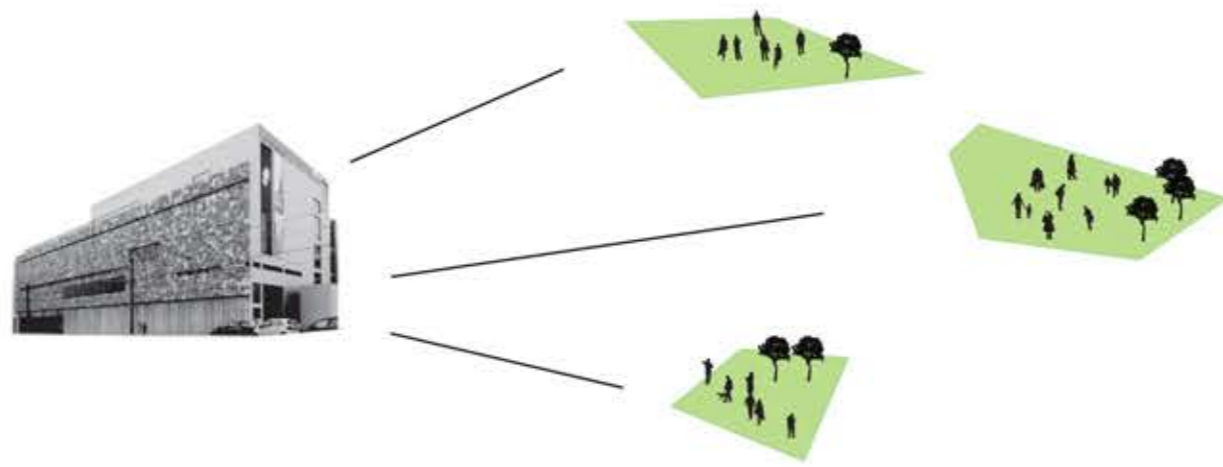

κριτήρια
οικοπεδων

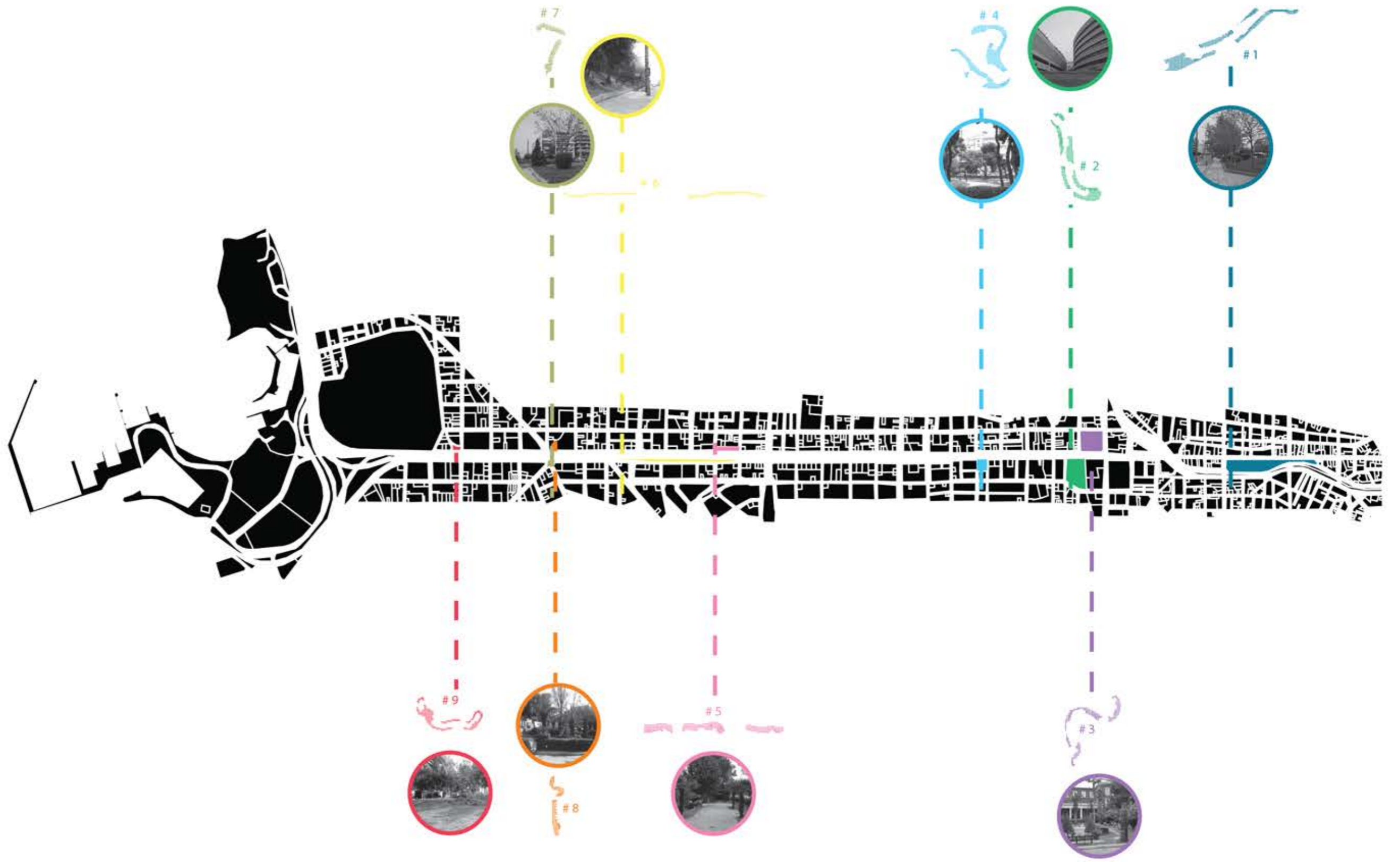

σημεία
παρεμβασής

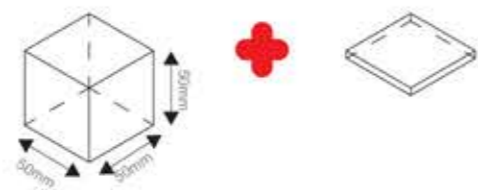

ο κύβος ως στοιχείο επανάληψης

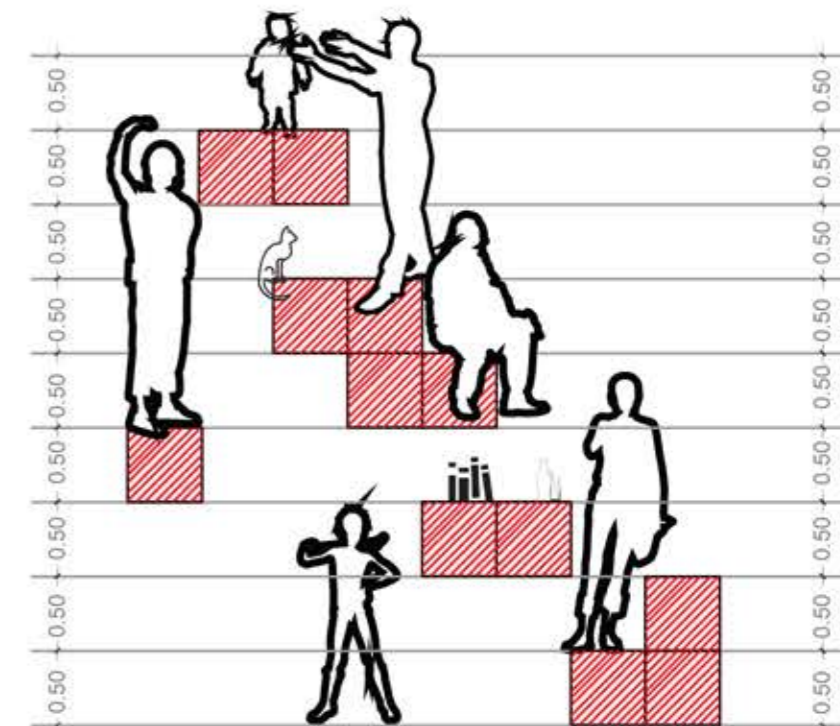
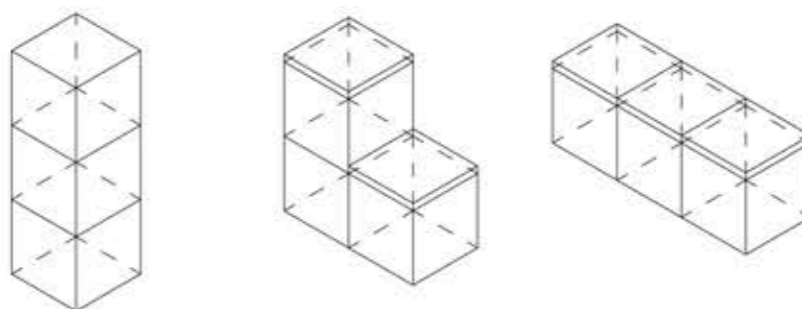

Κλ. 1:50



πιθανές μορφές της κατασκευής

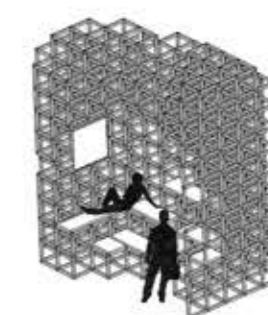
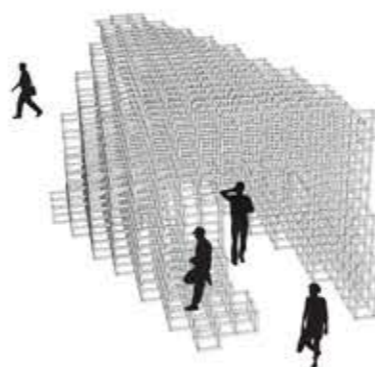
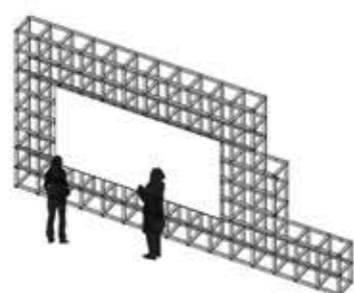

κύβος

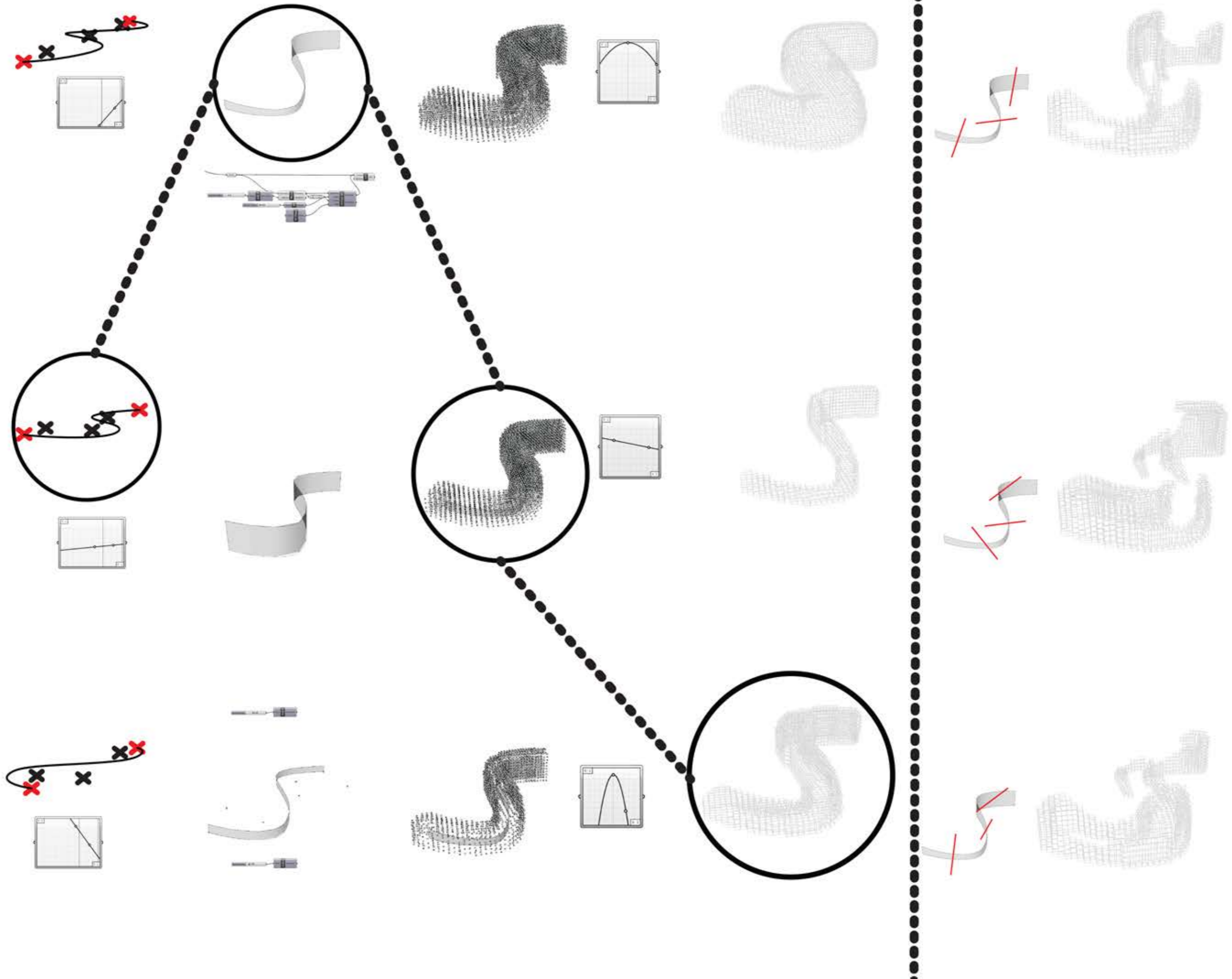

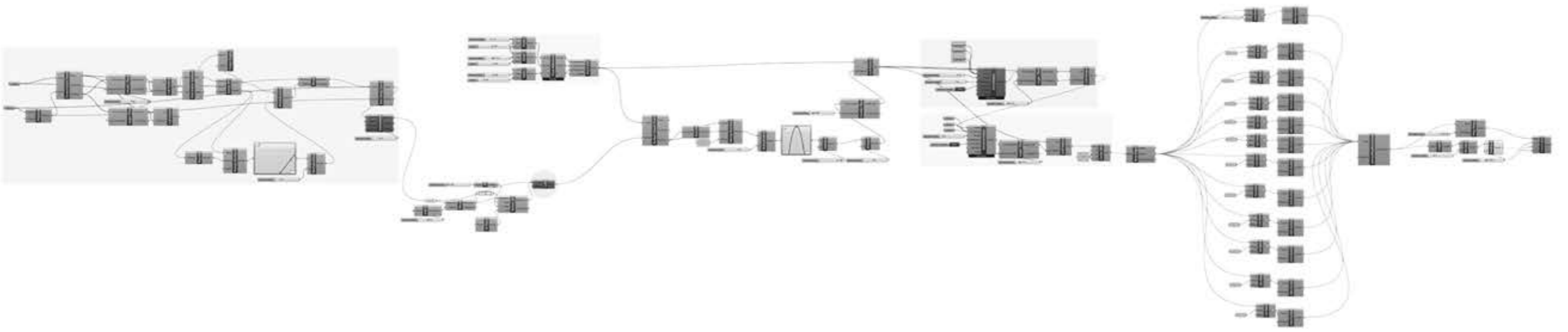

#1

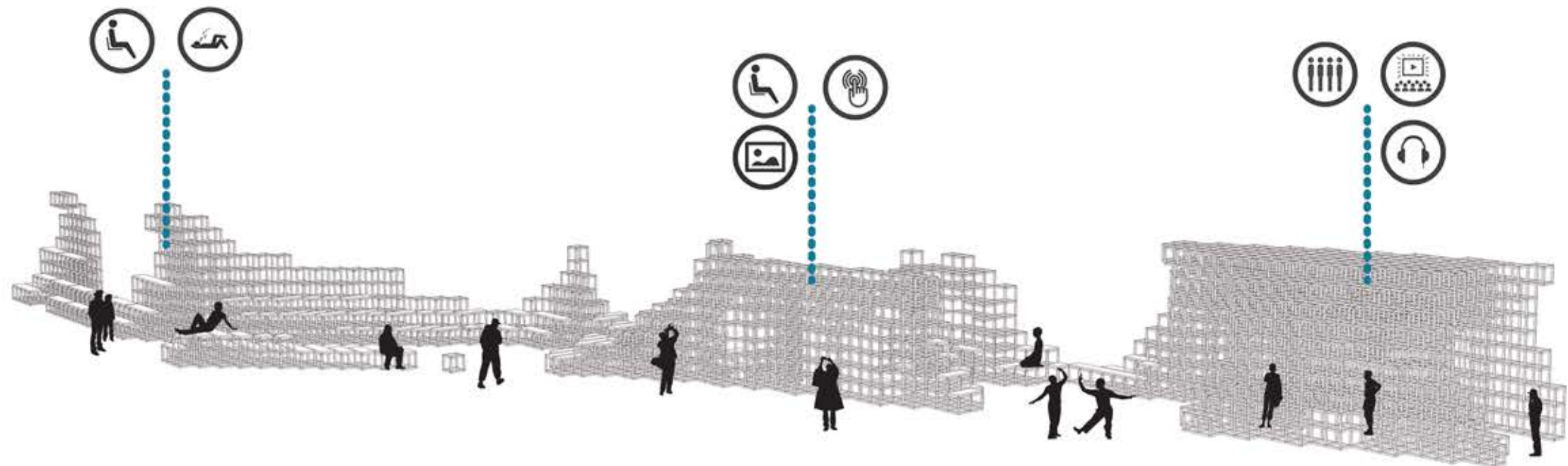
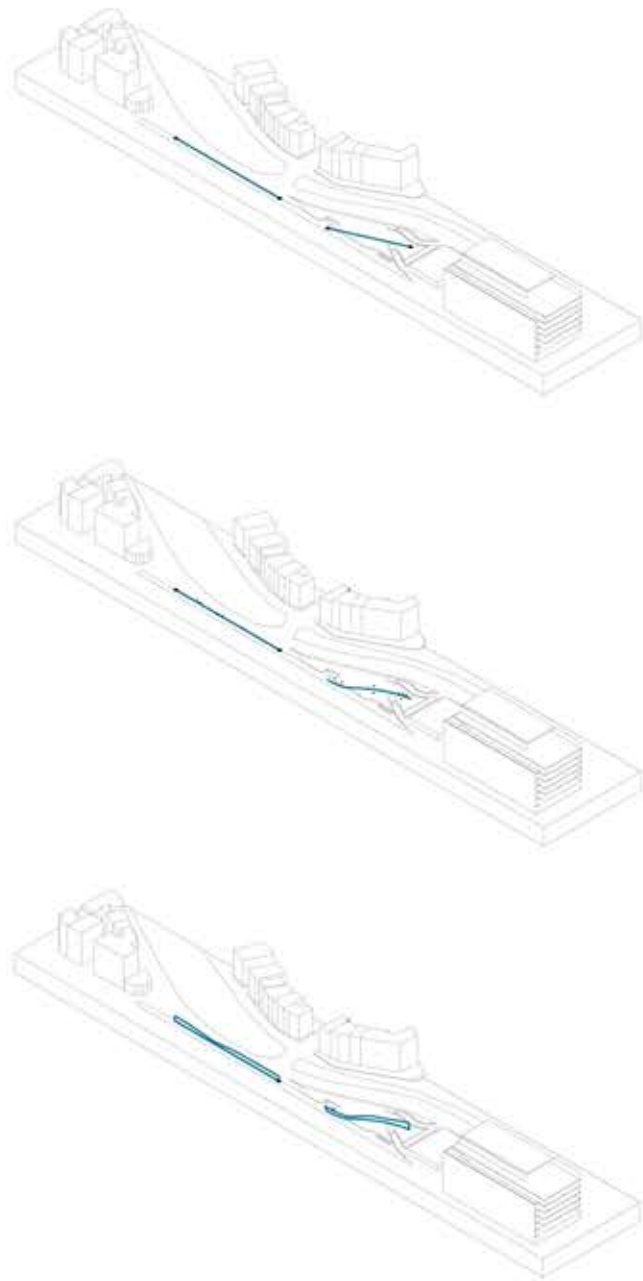

τμήμα α'-ενδεικτικές χρήσεις

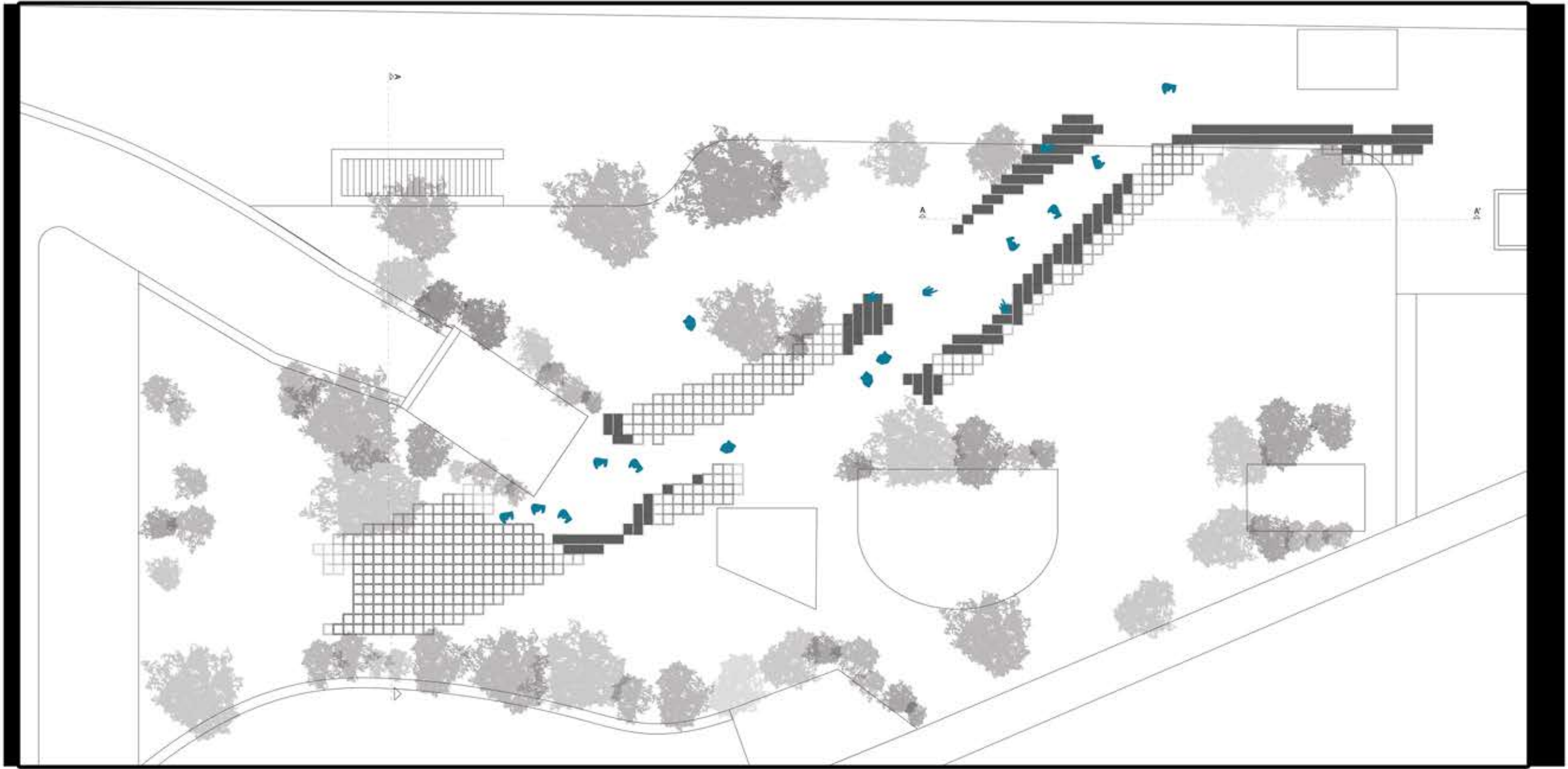

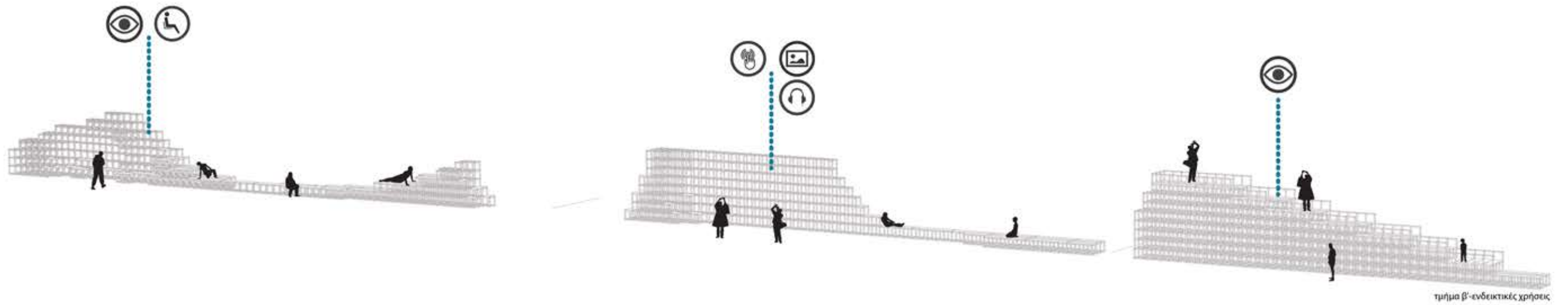
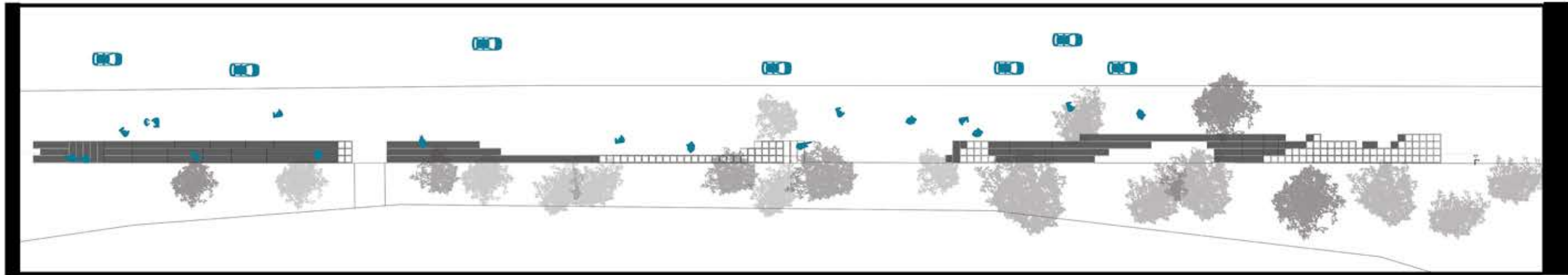

τμήμα β'-ενδεικτικές χρήσεις

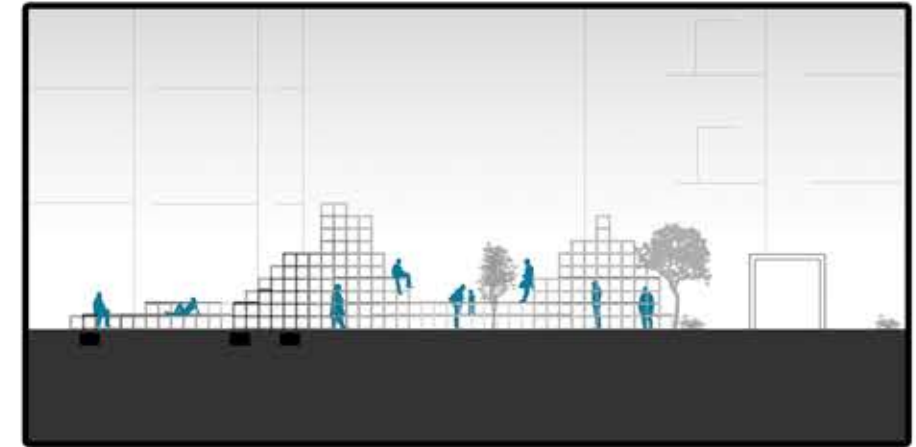
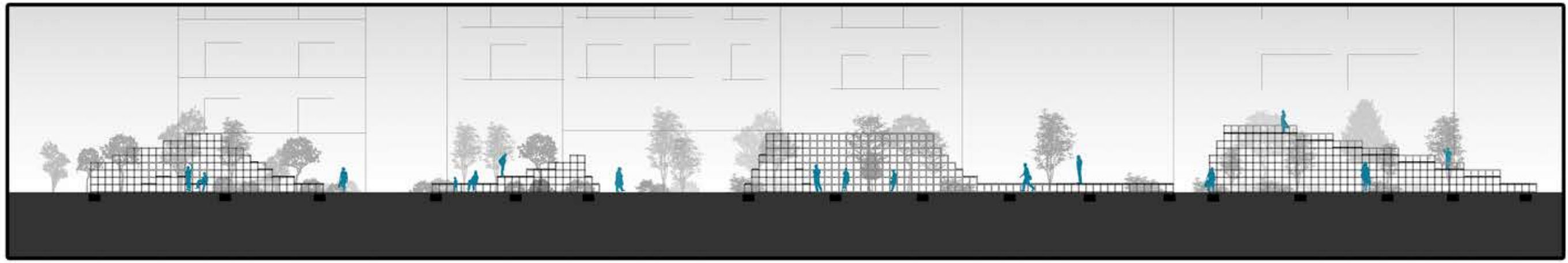

#2

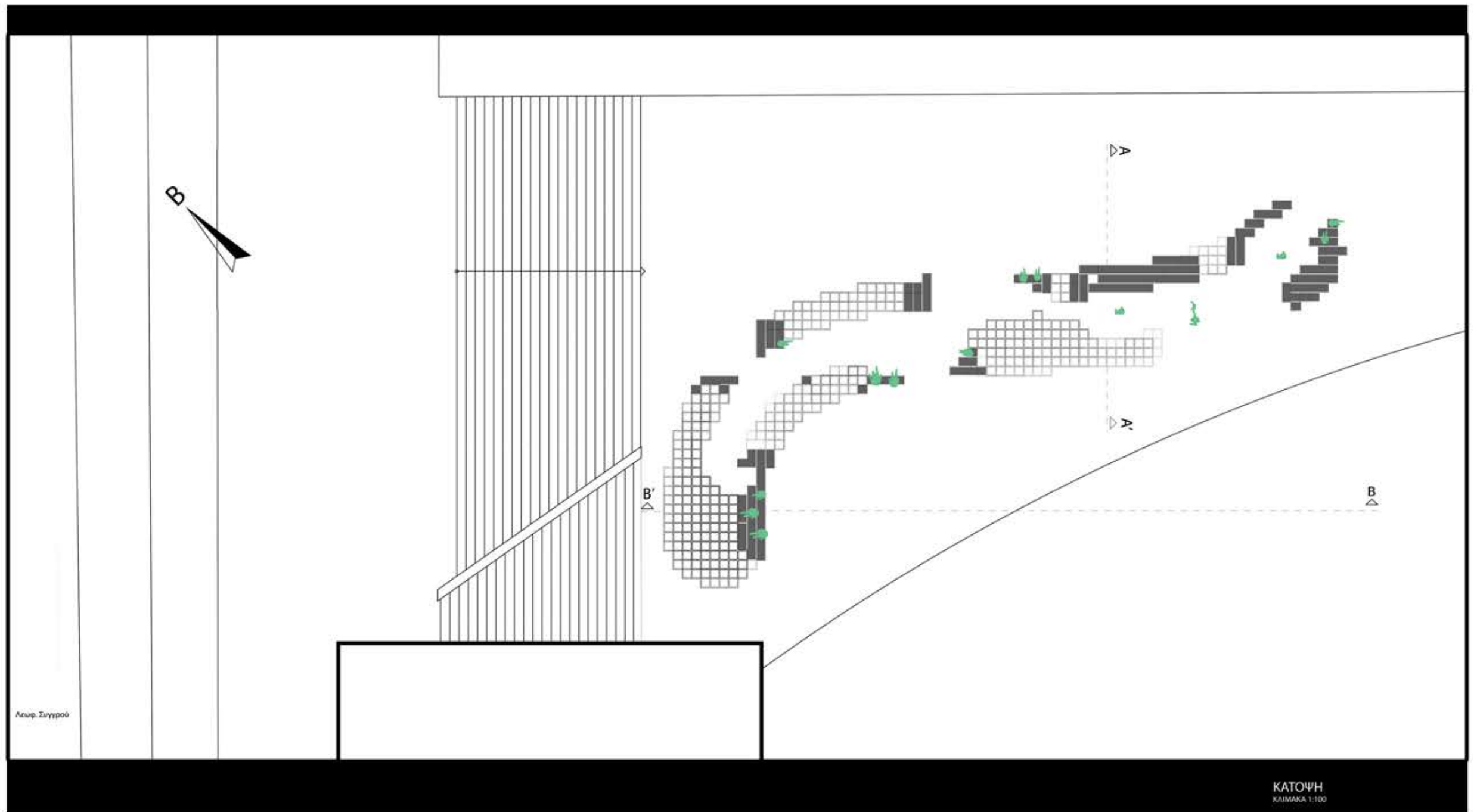

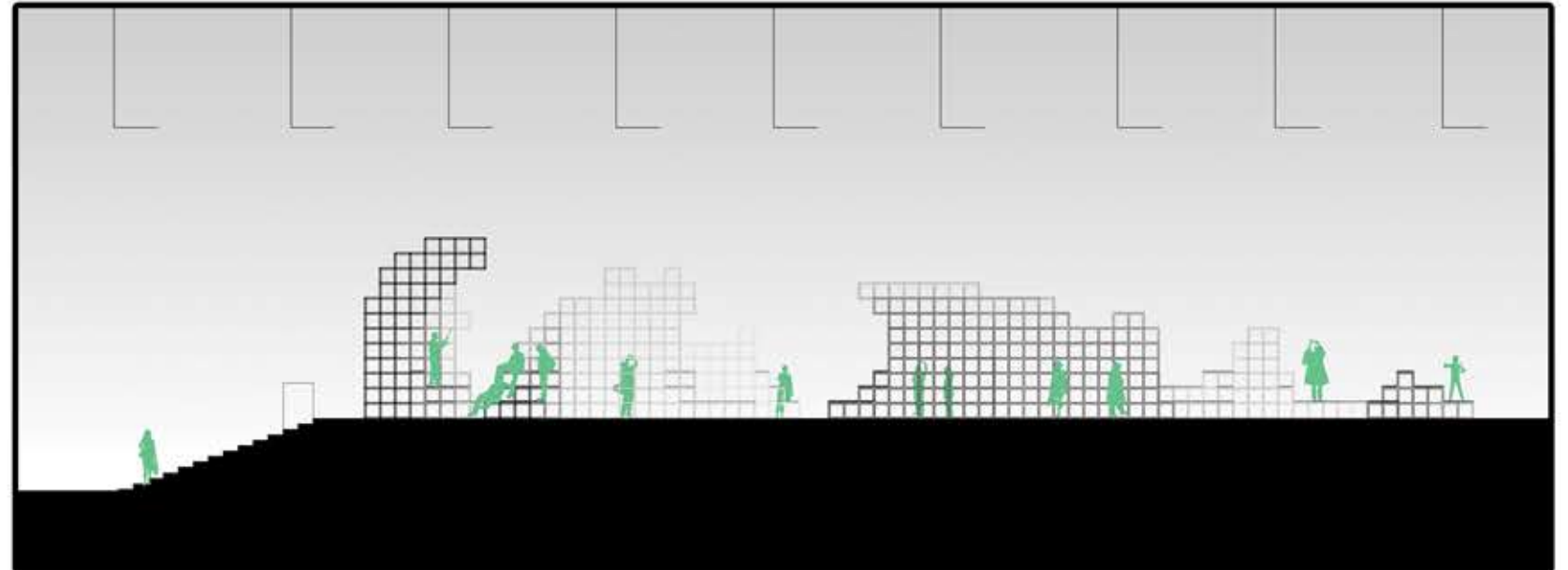
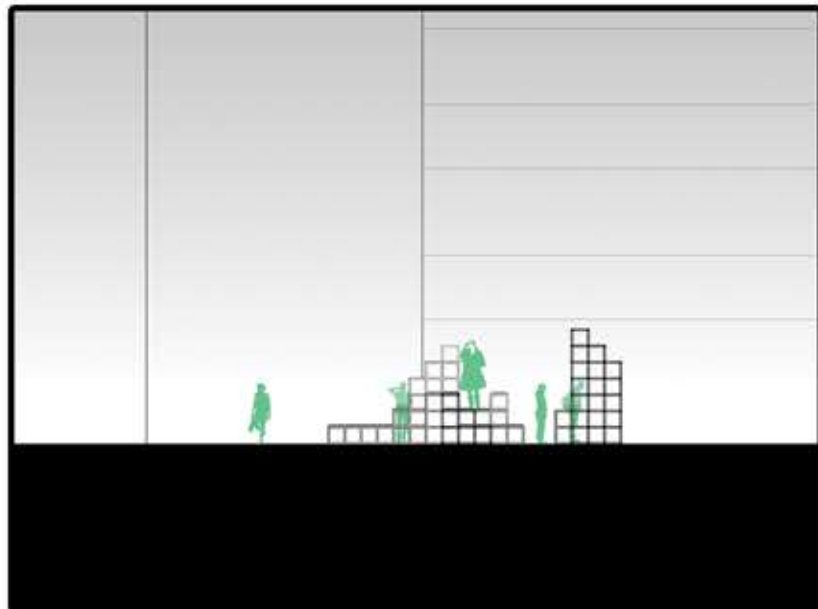
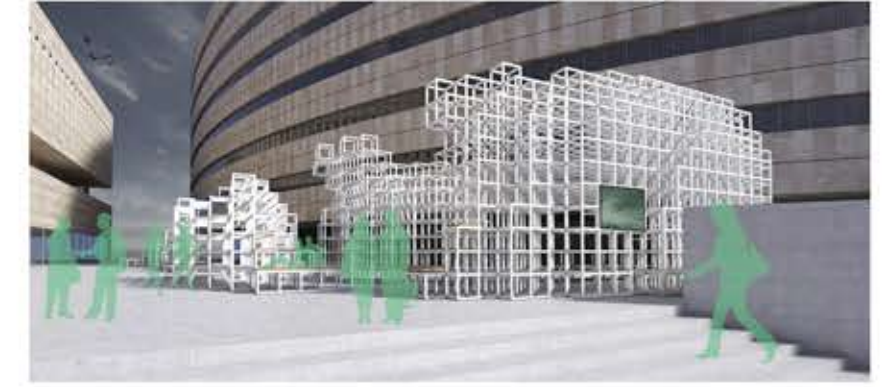
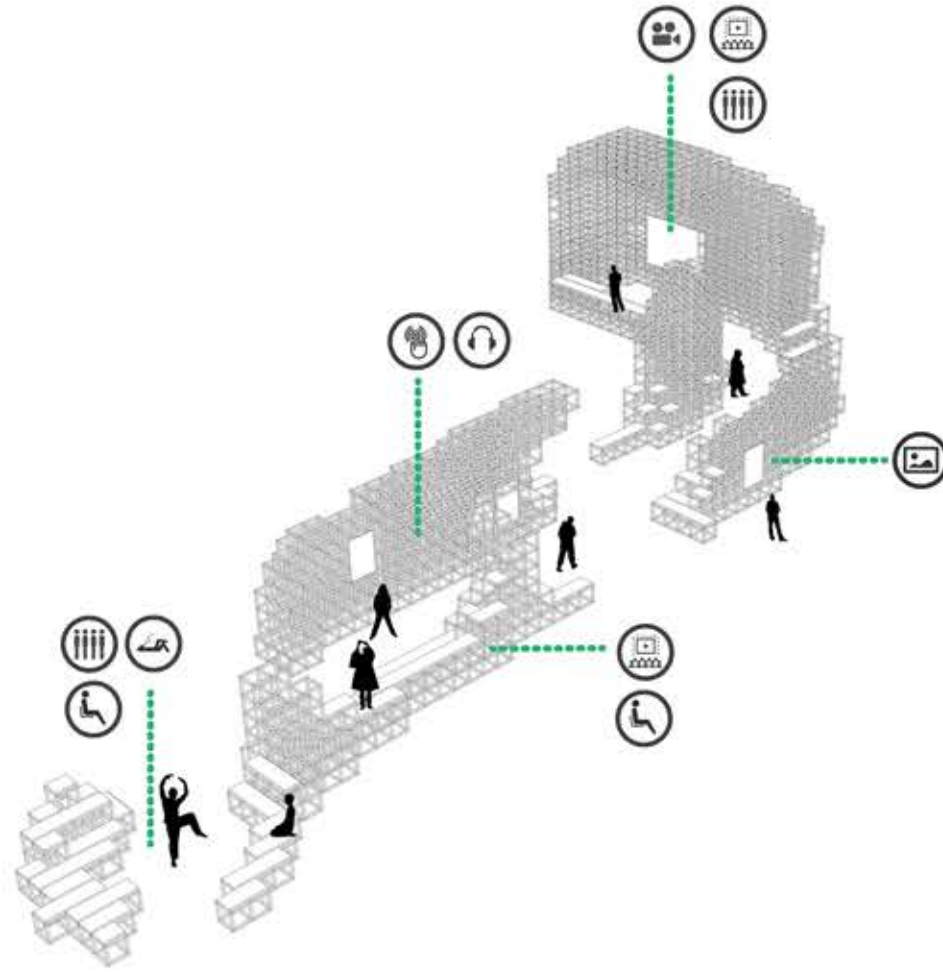
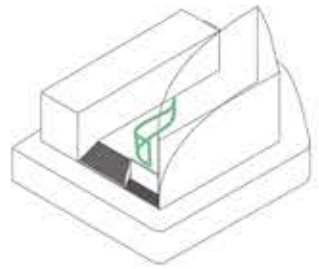
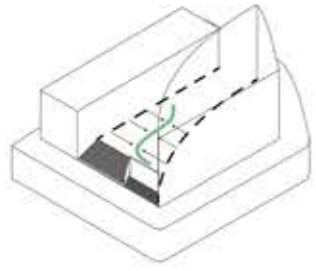
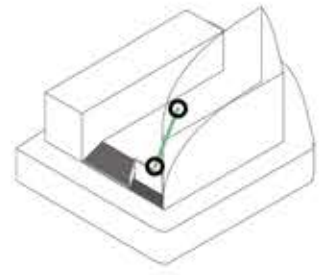

#3

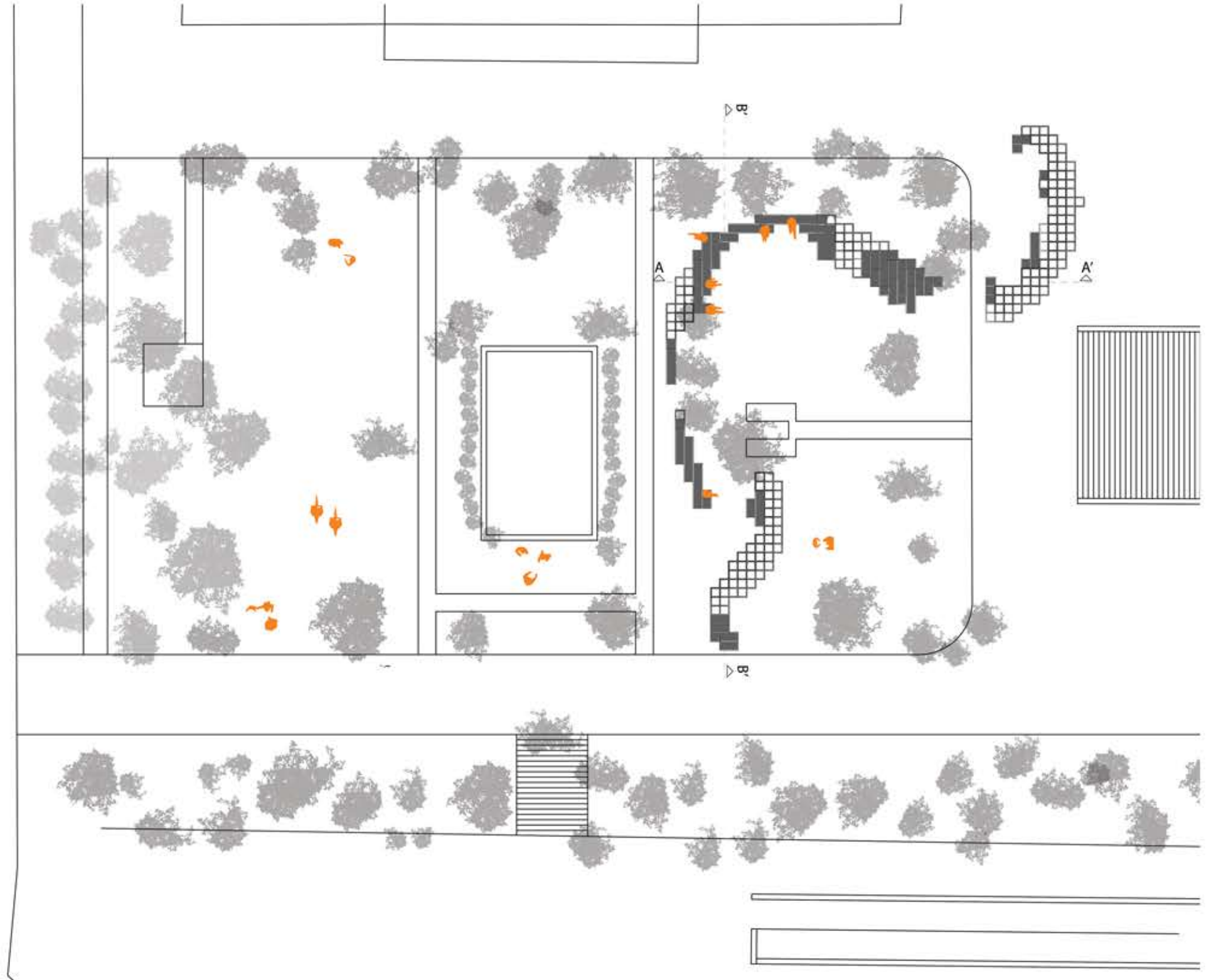
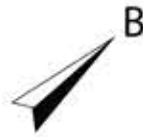

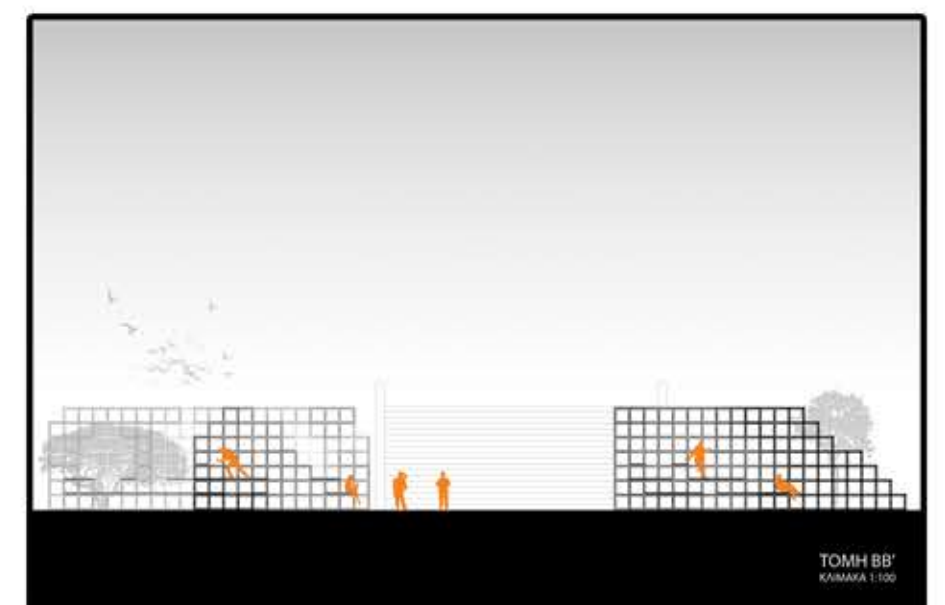
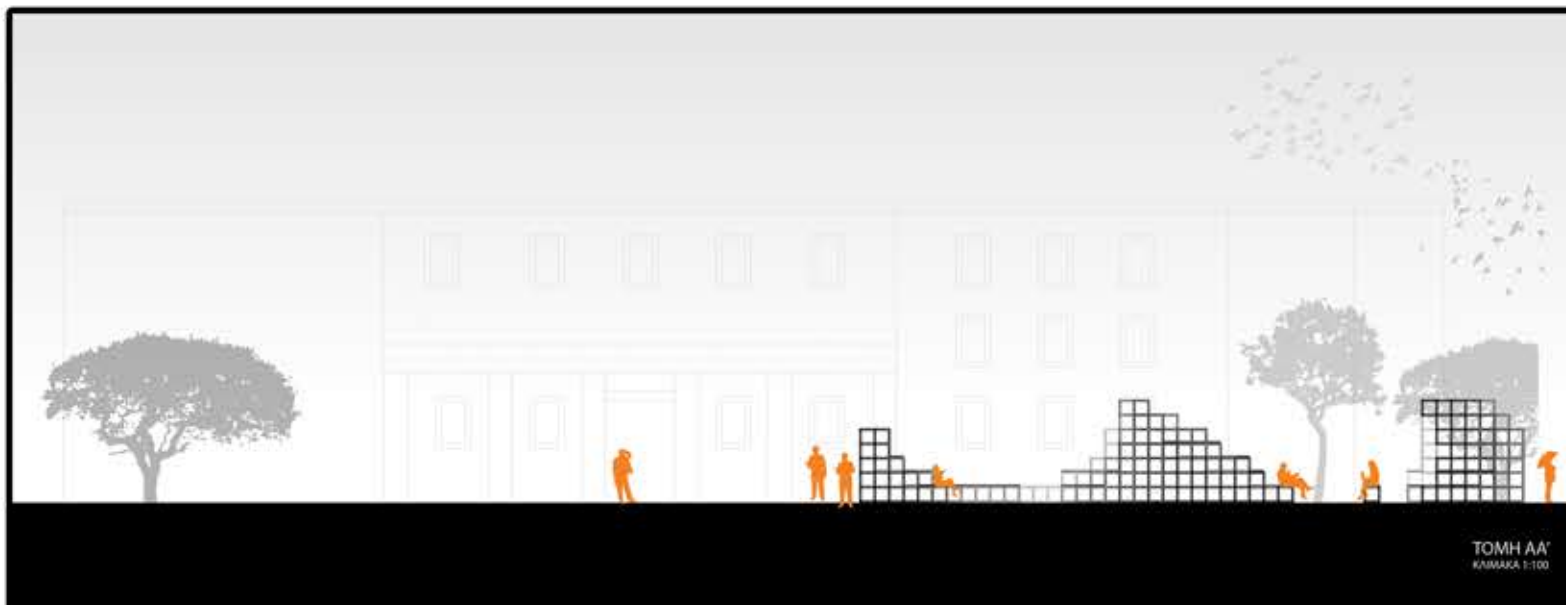
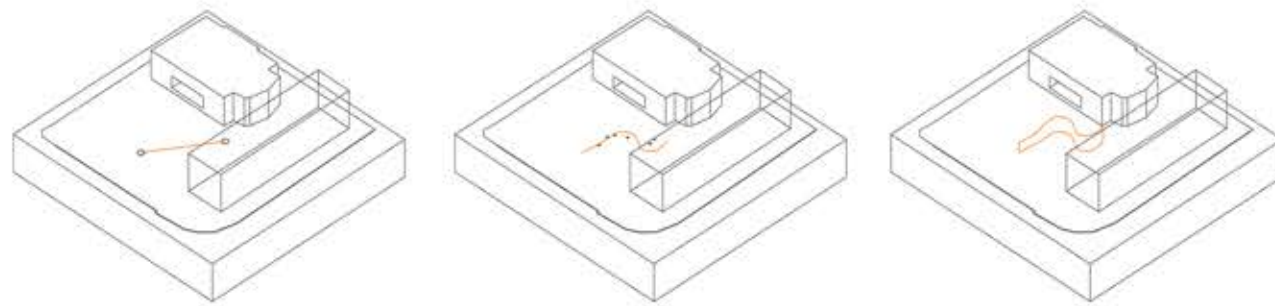
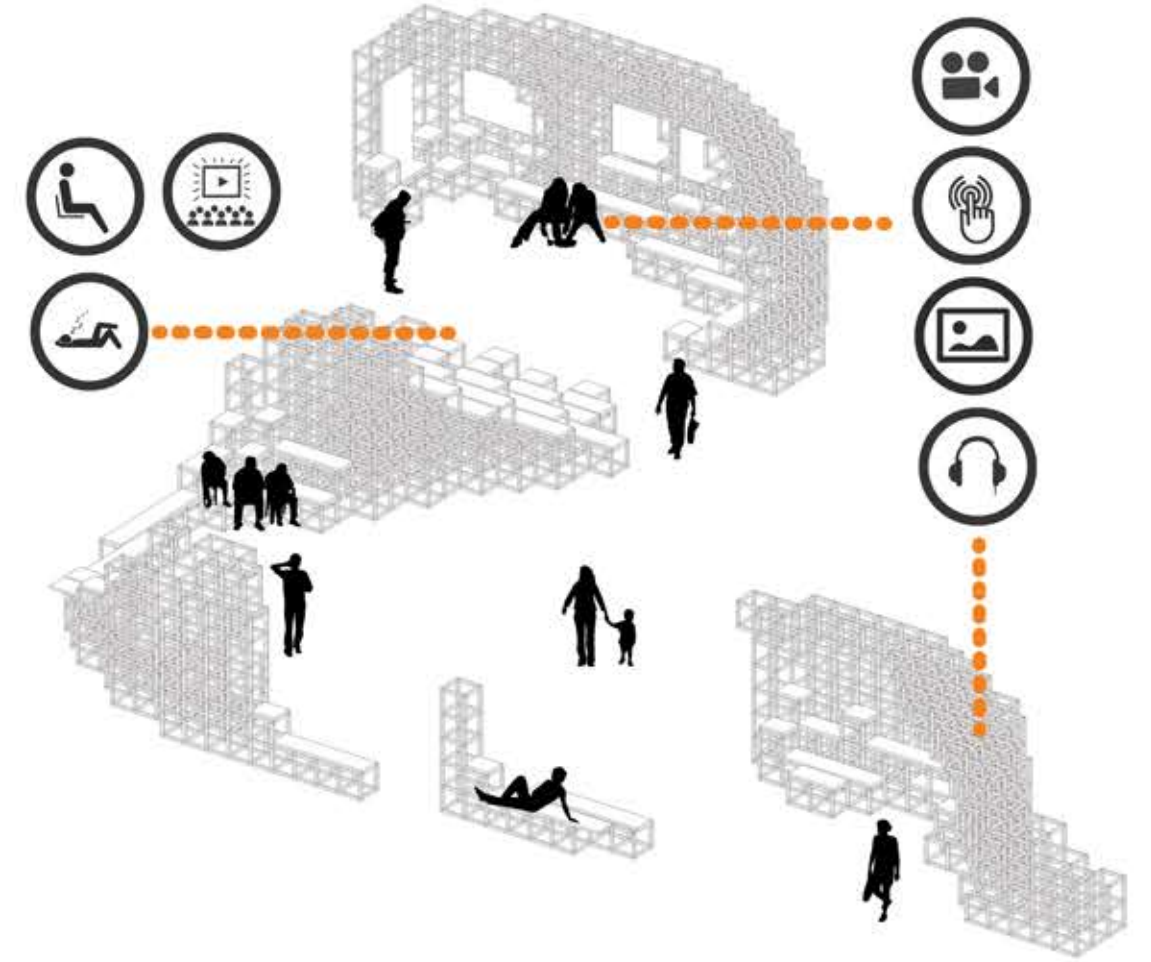
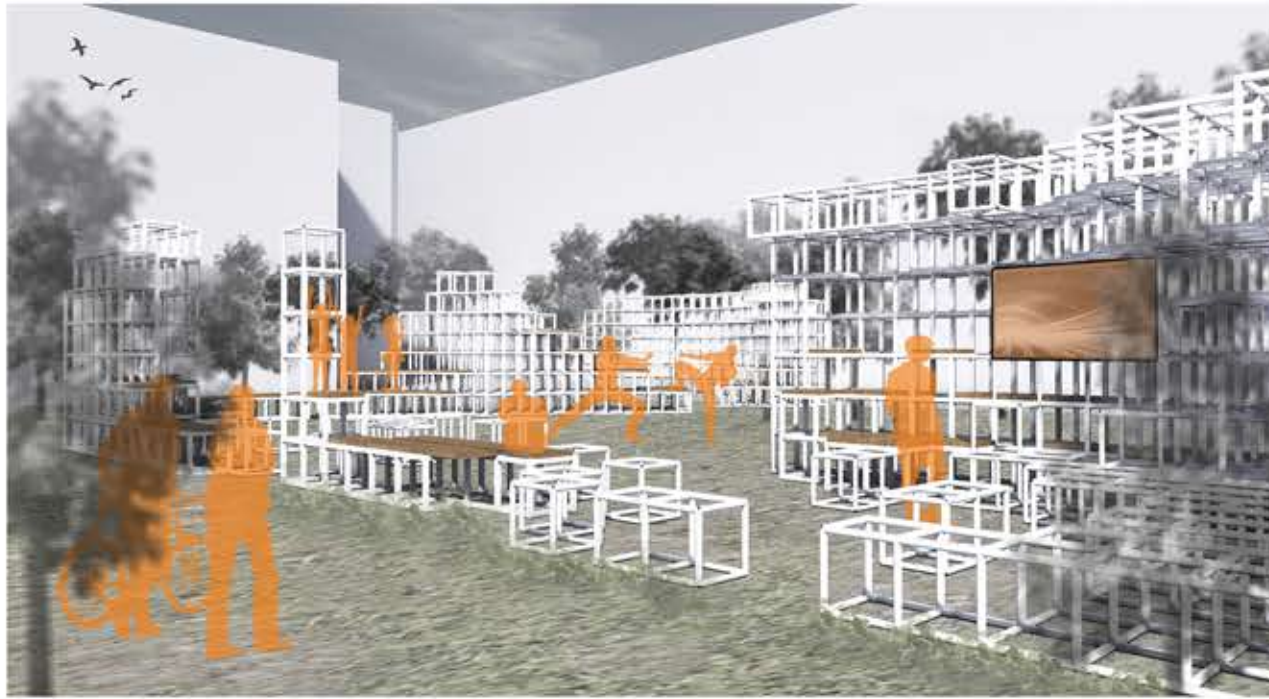

#4

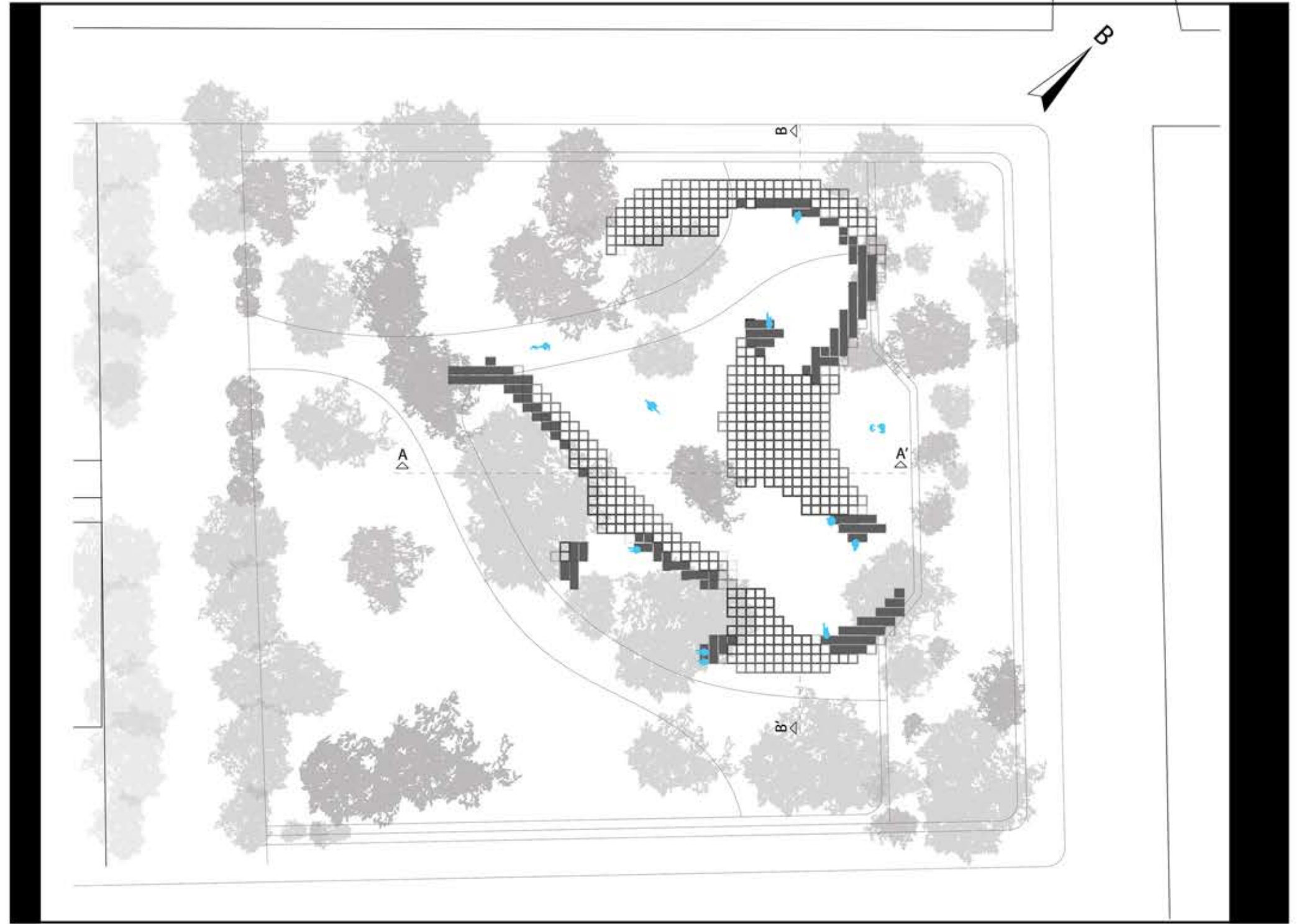

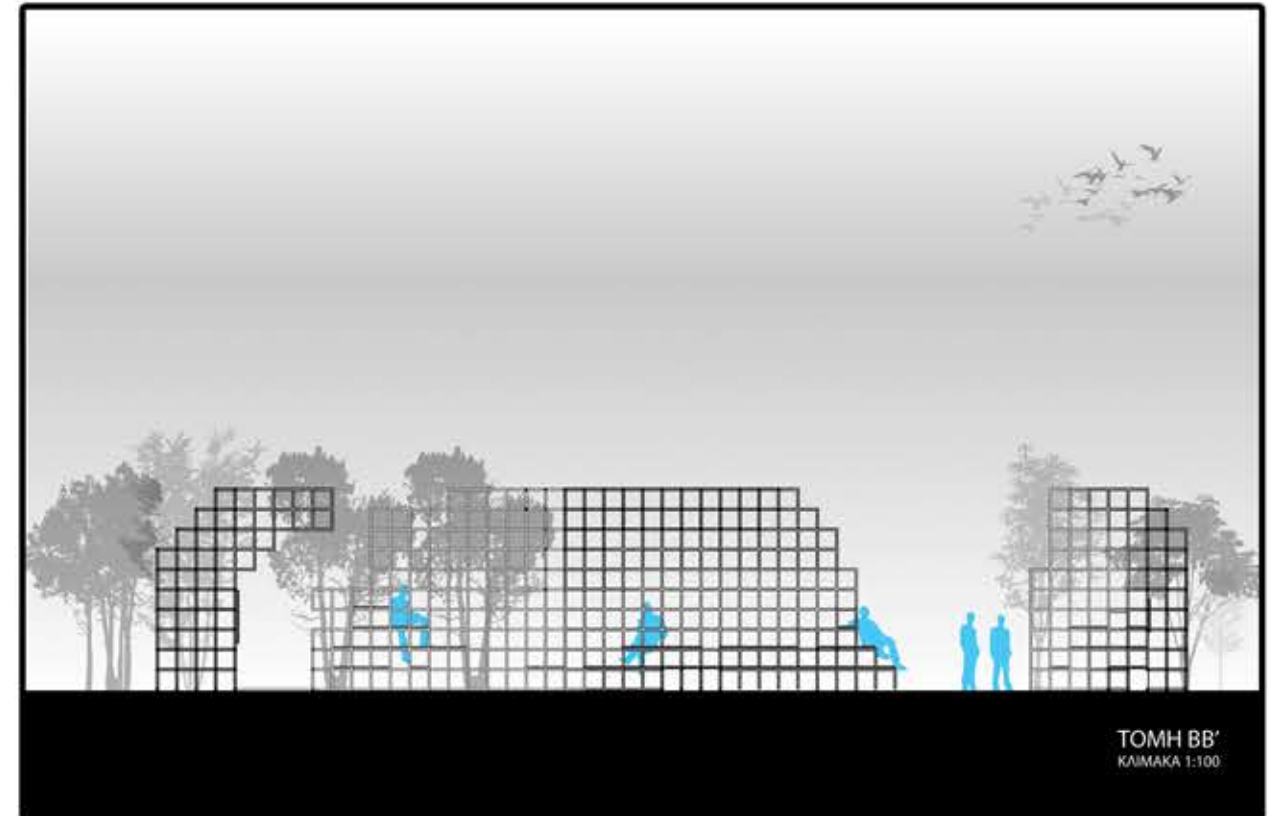
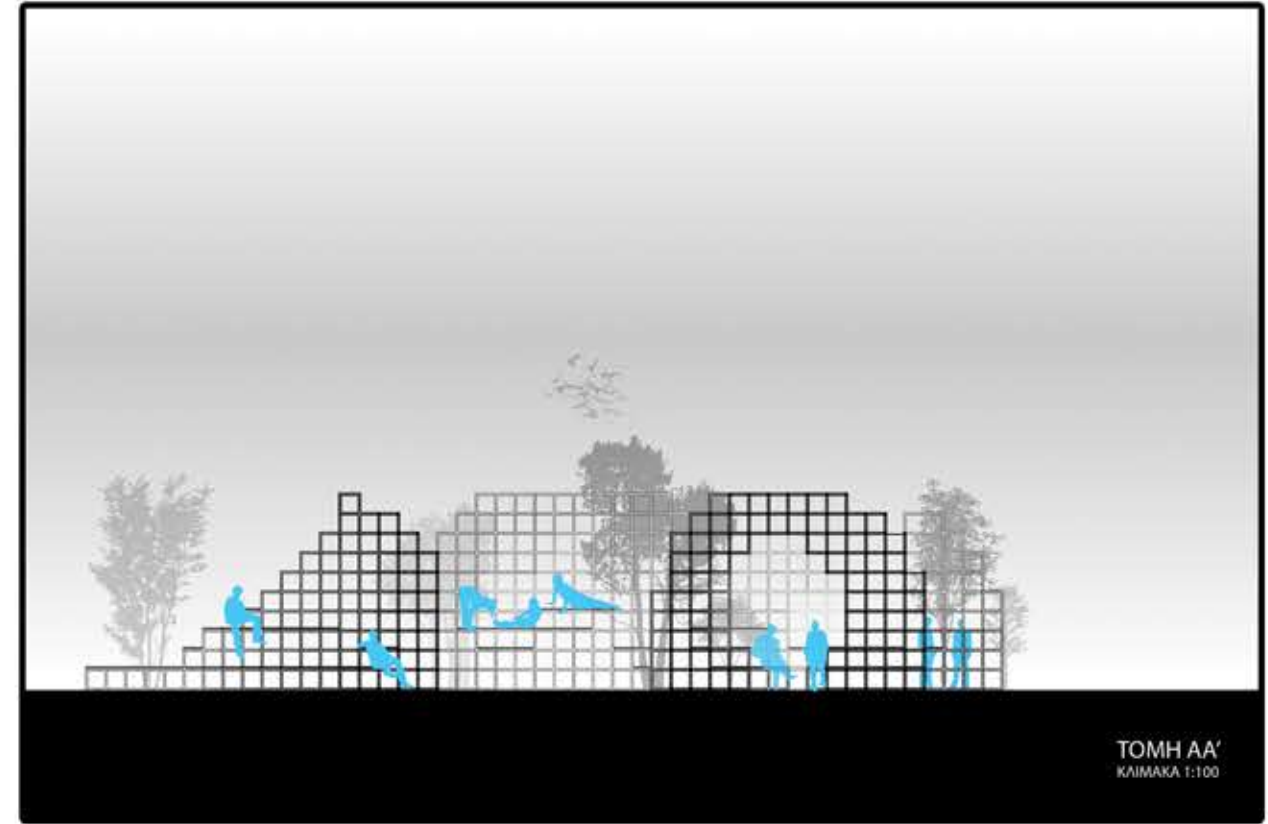
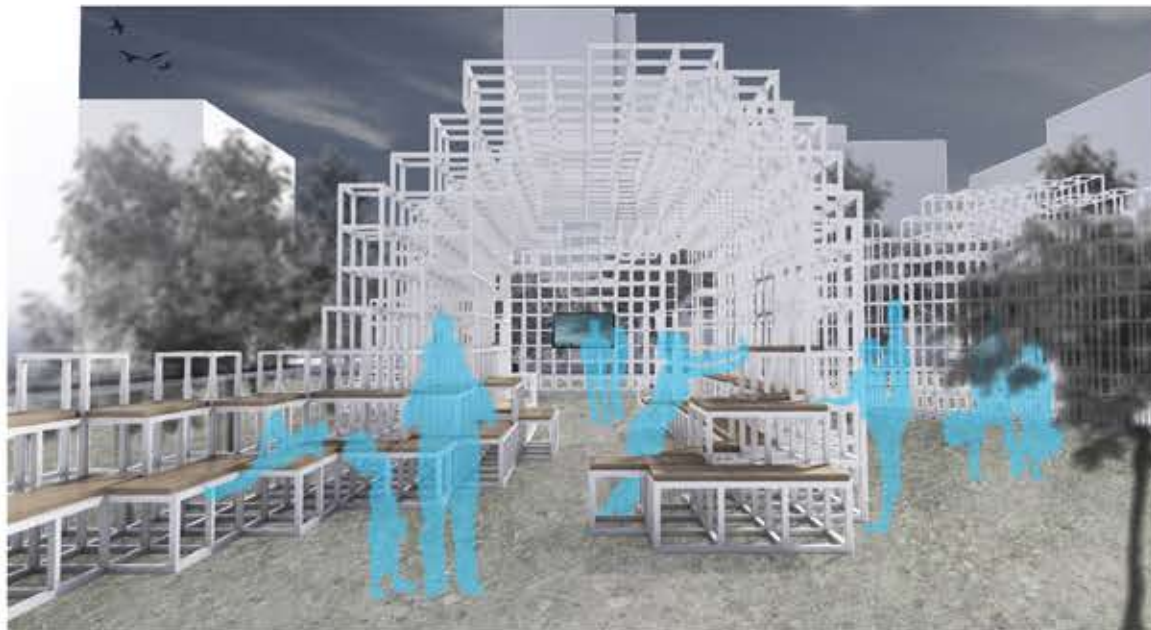
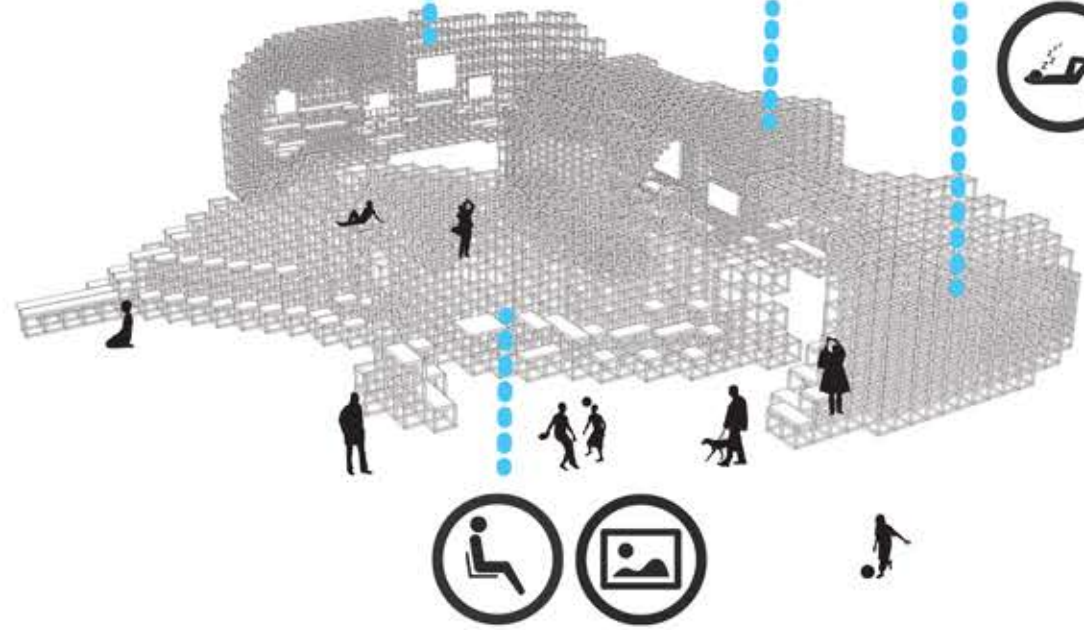
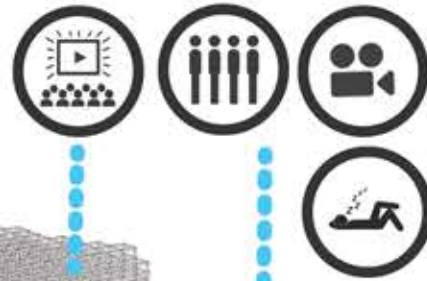
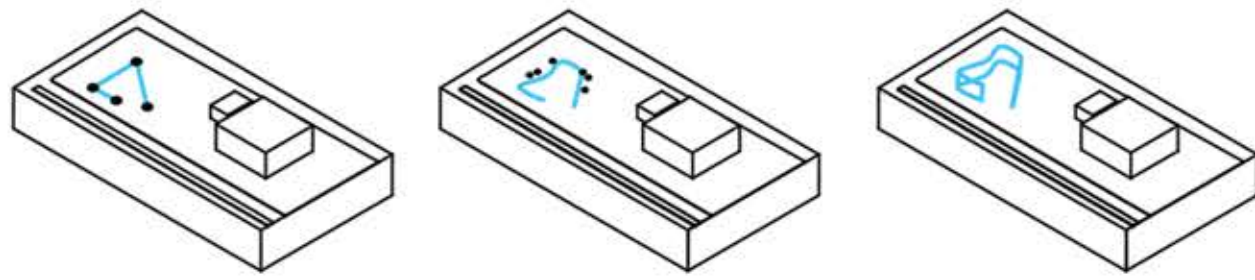

#5

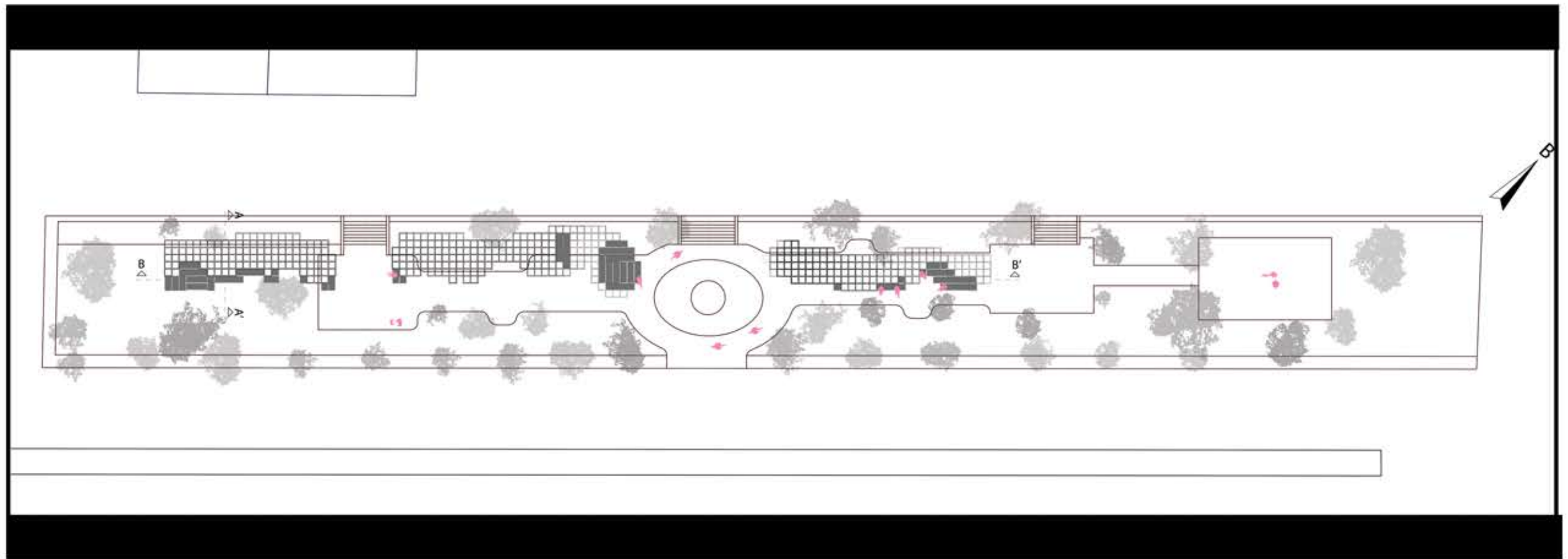

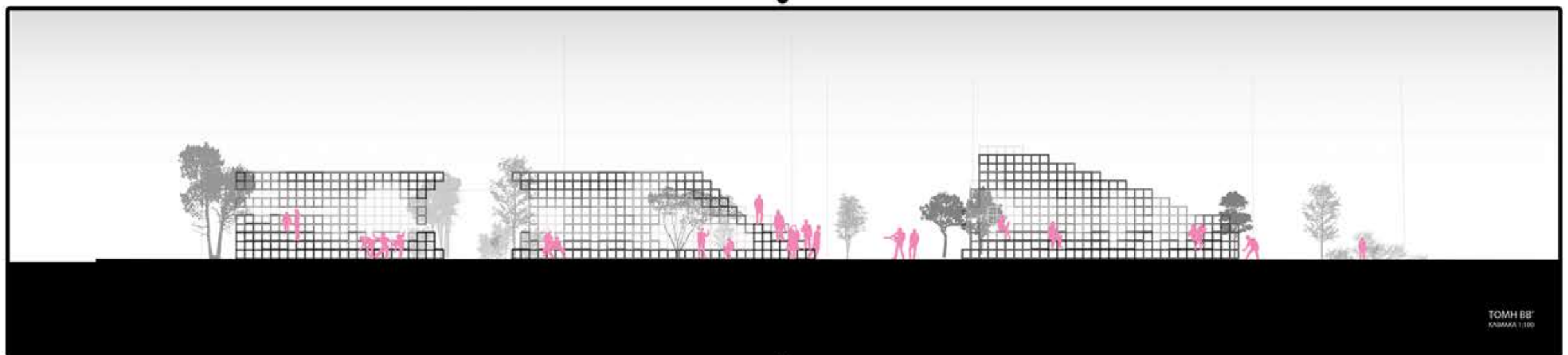
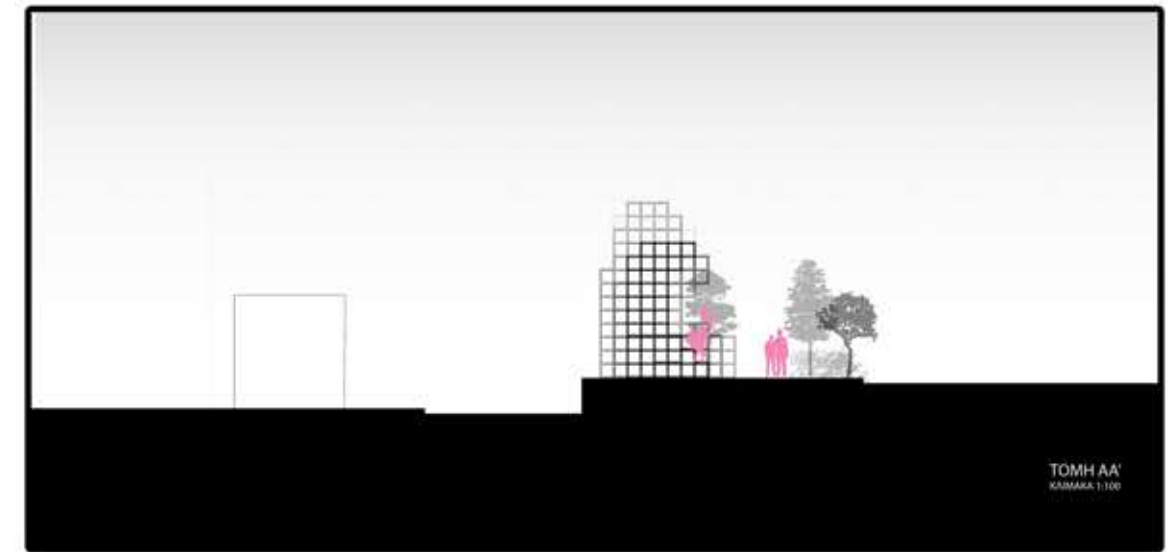
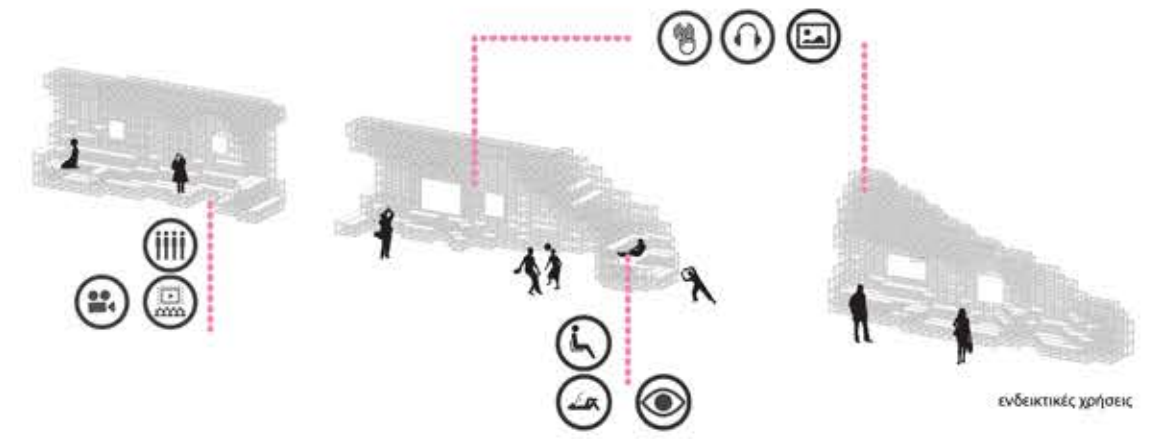
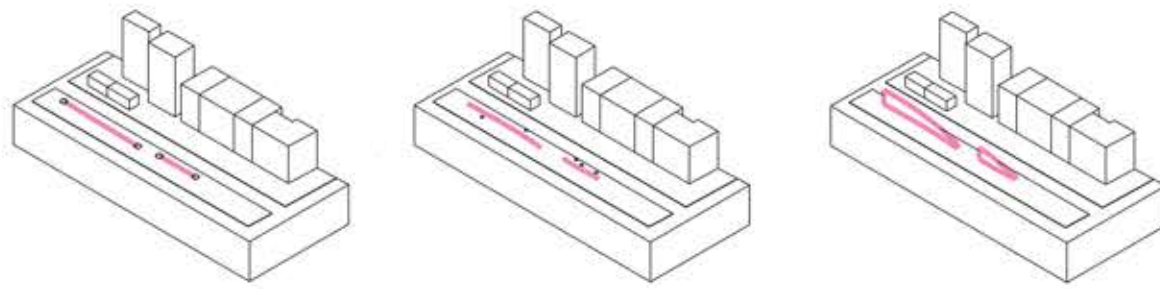

#6

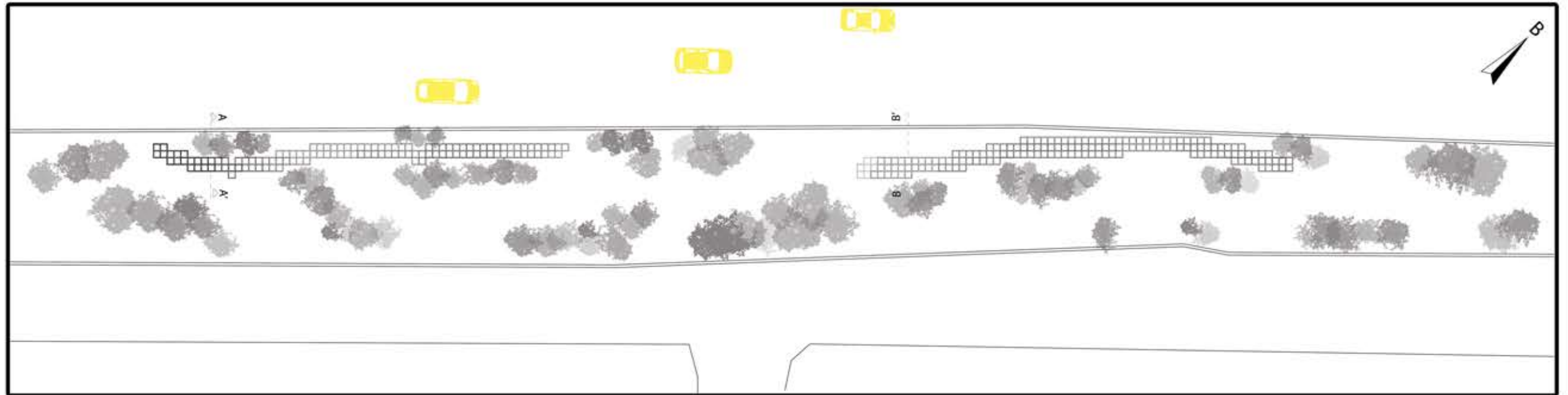

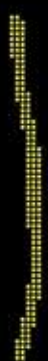
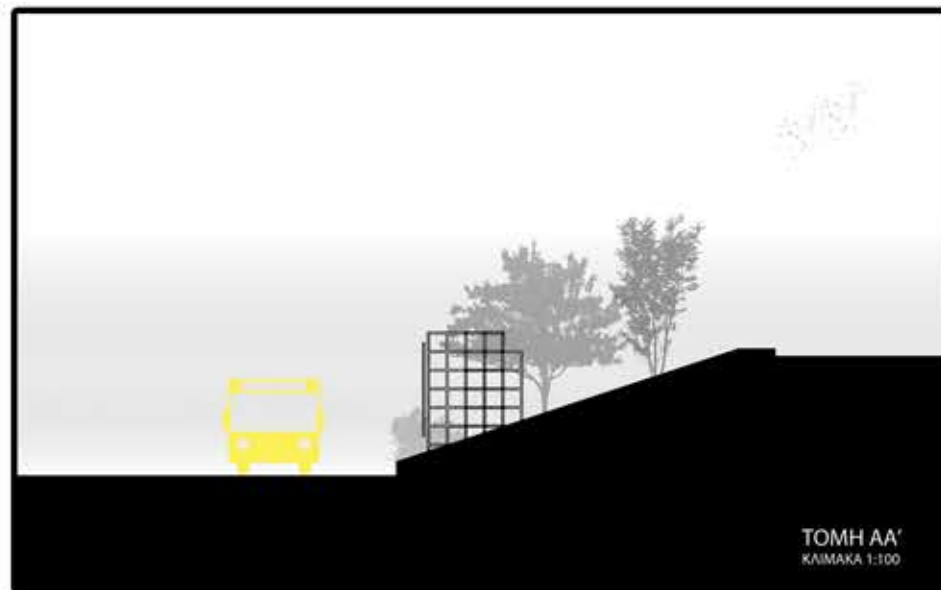
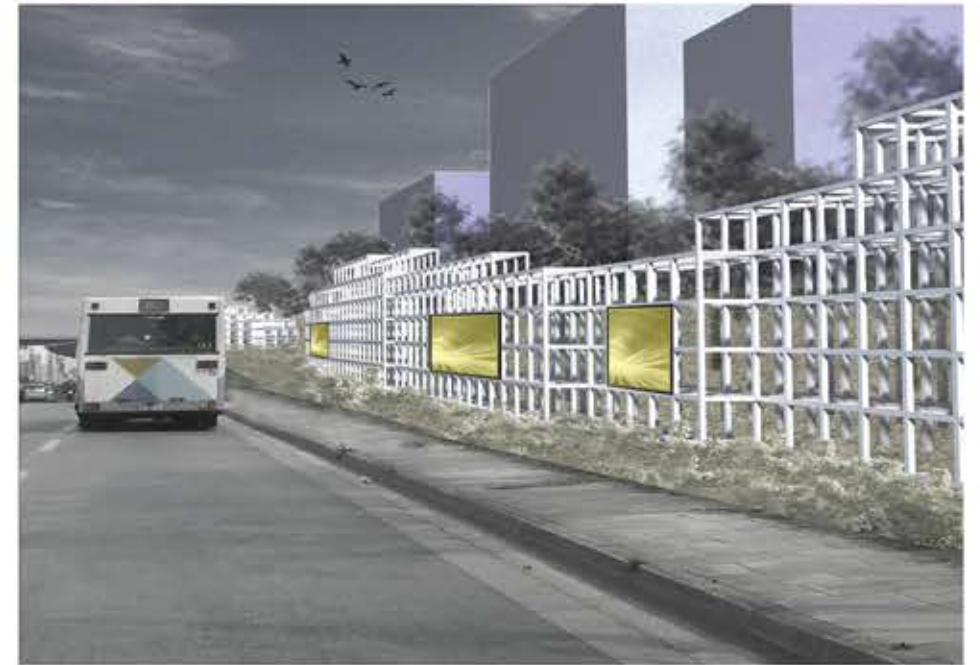
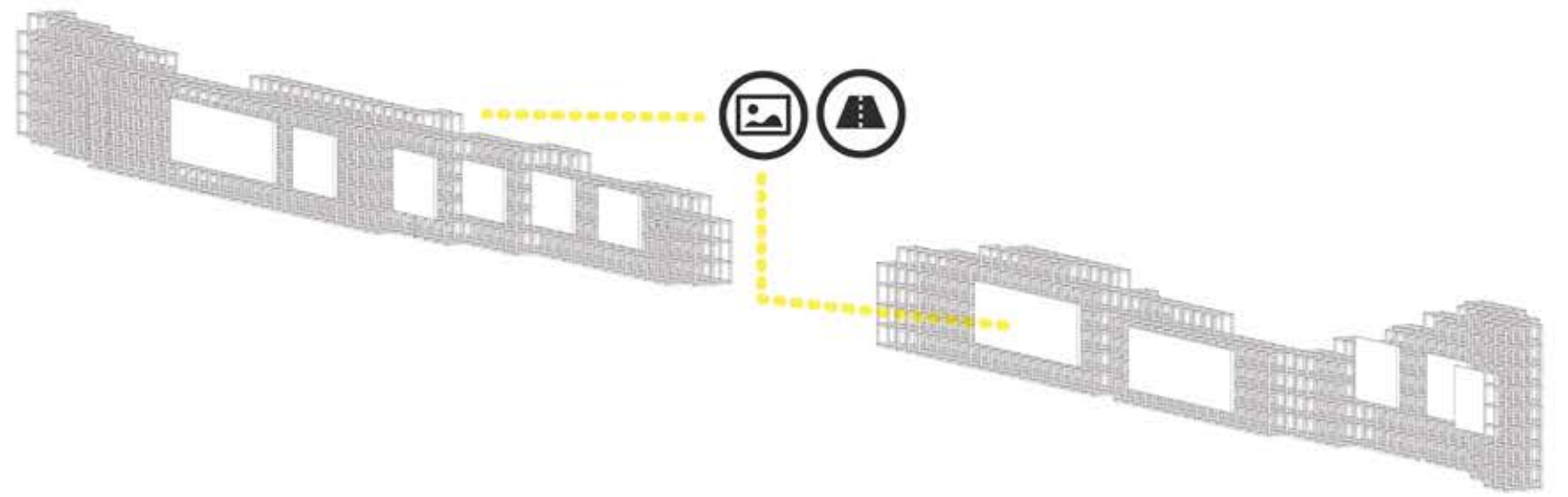
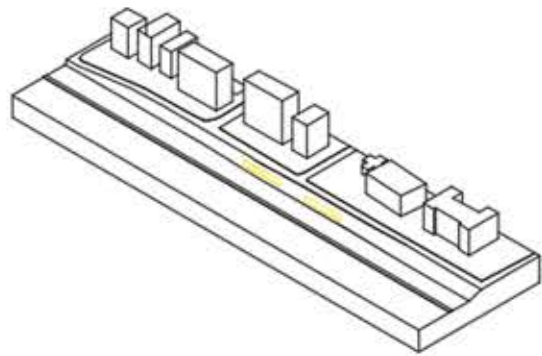
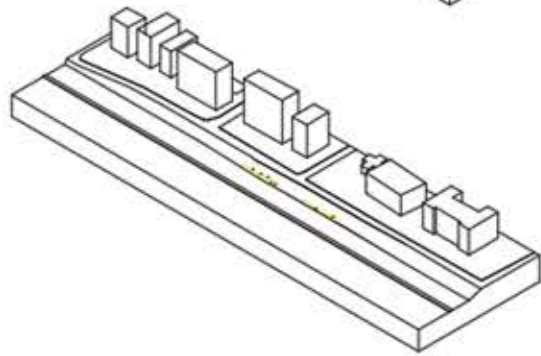
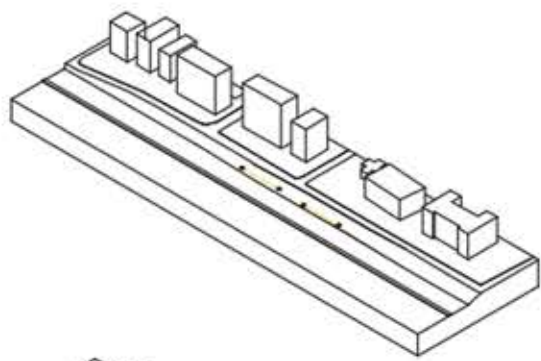

#7

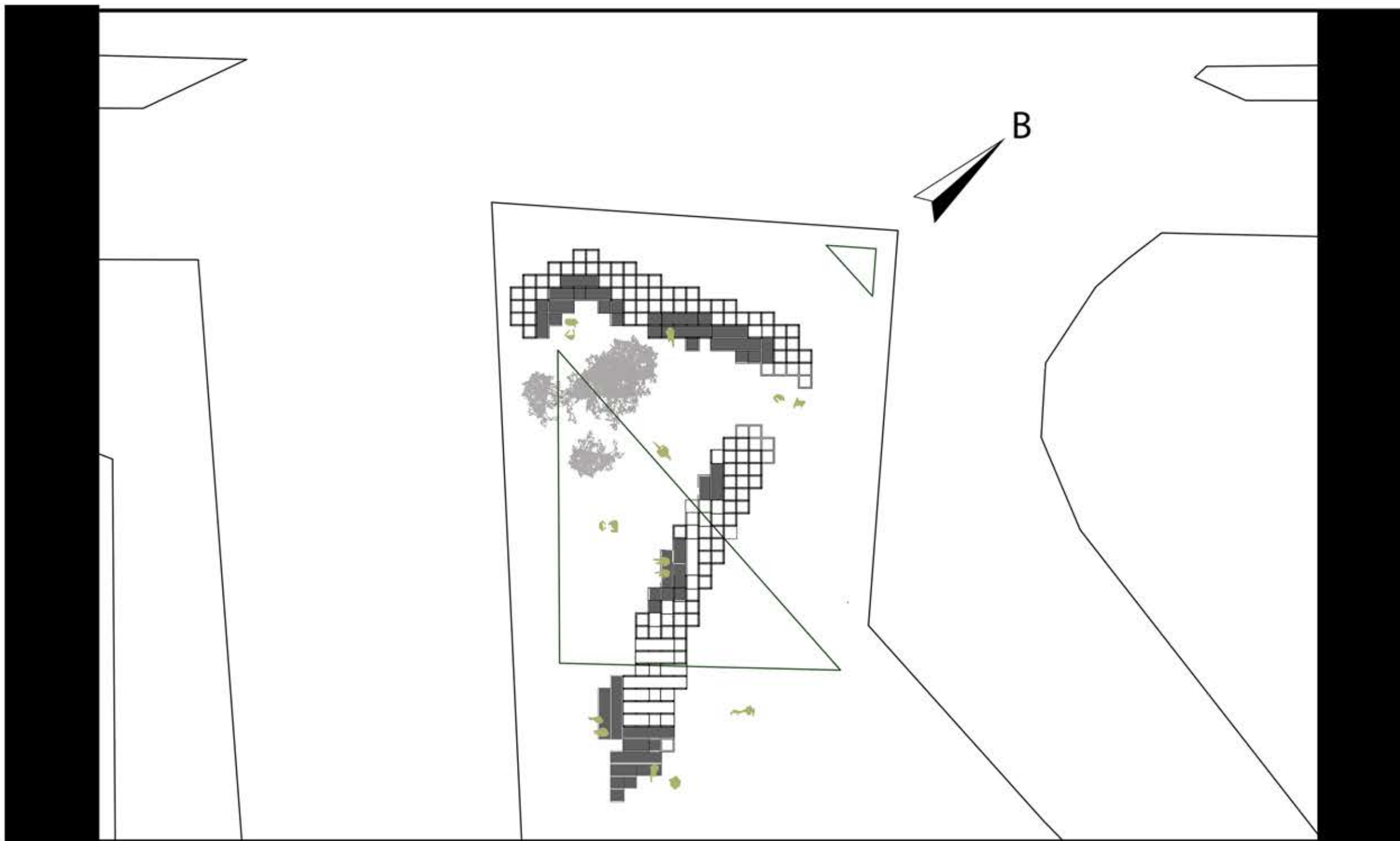

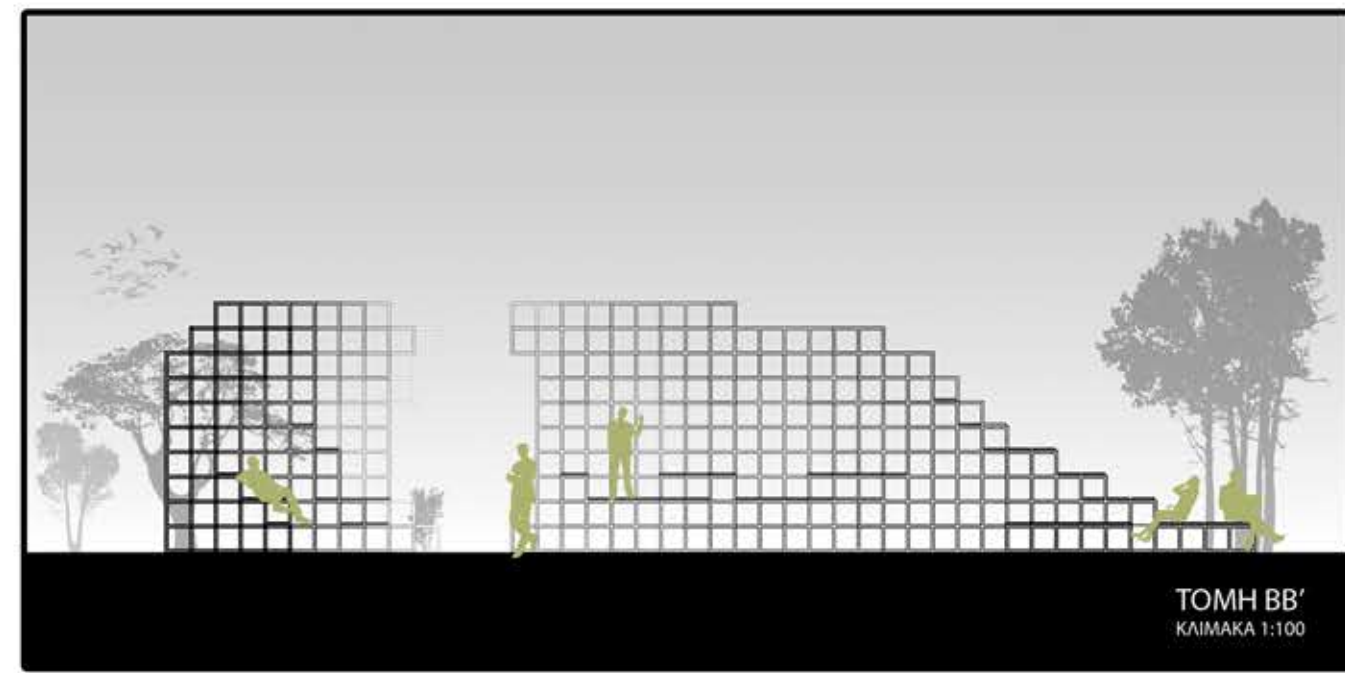
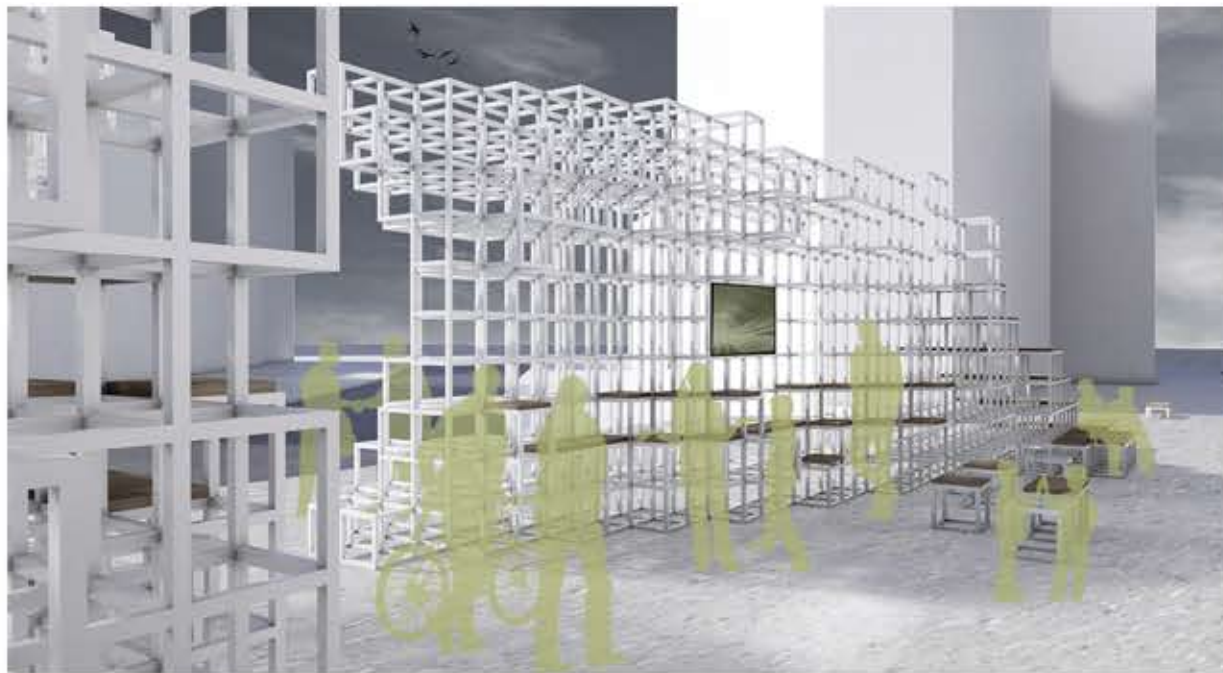
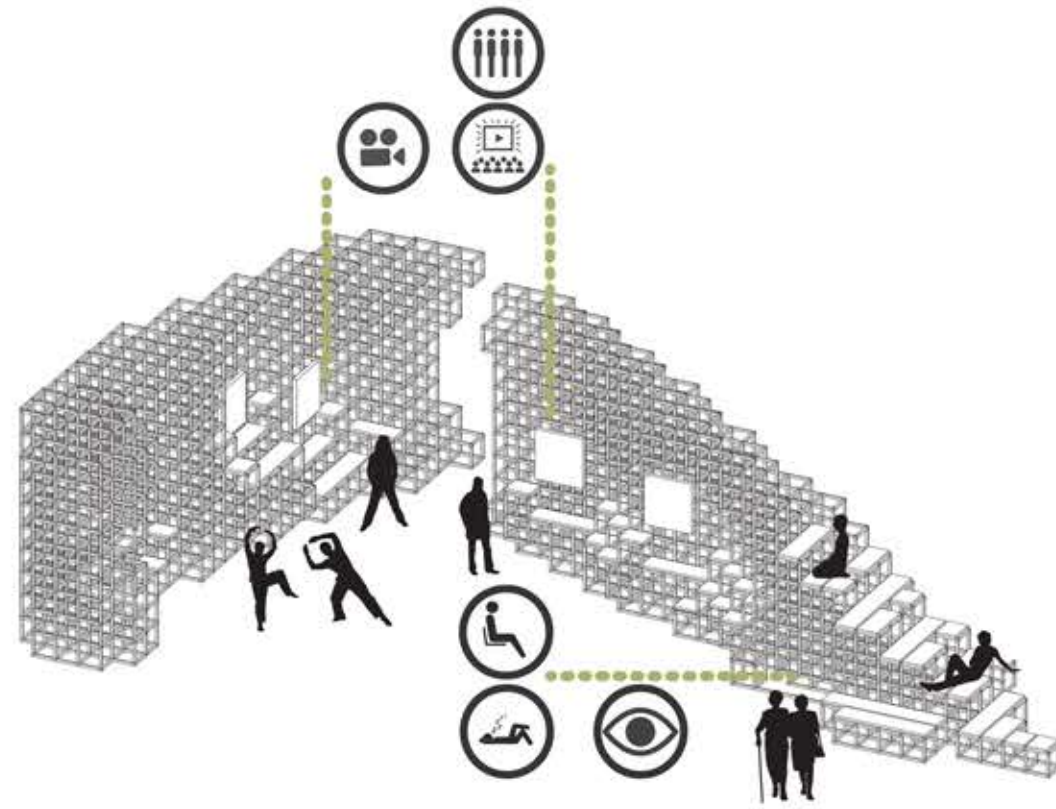
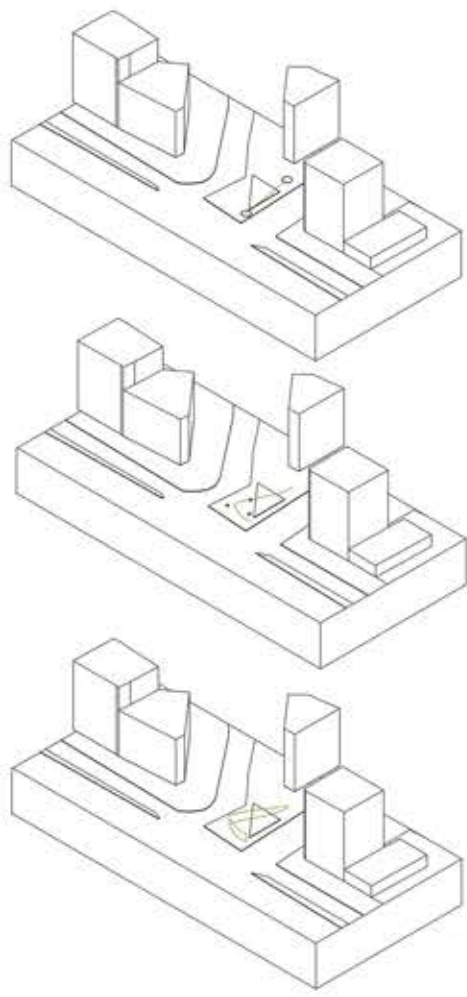

#8

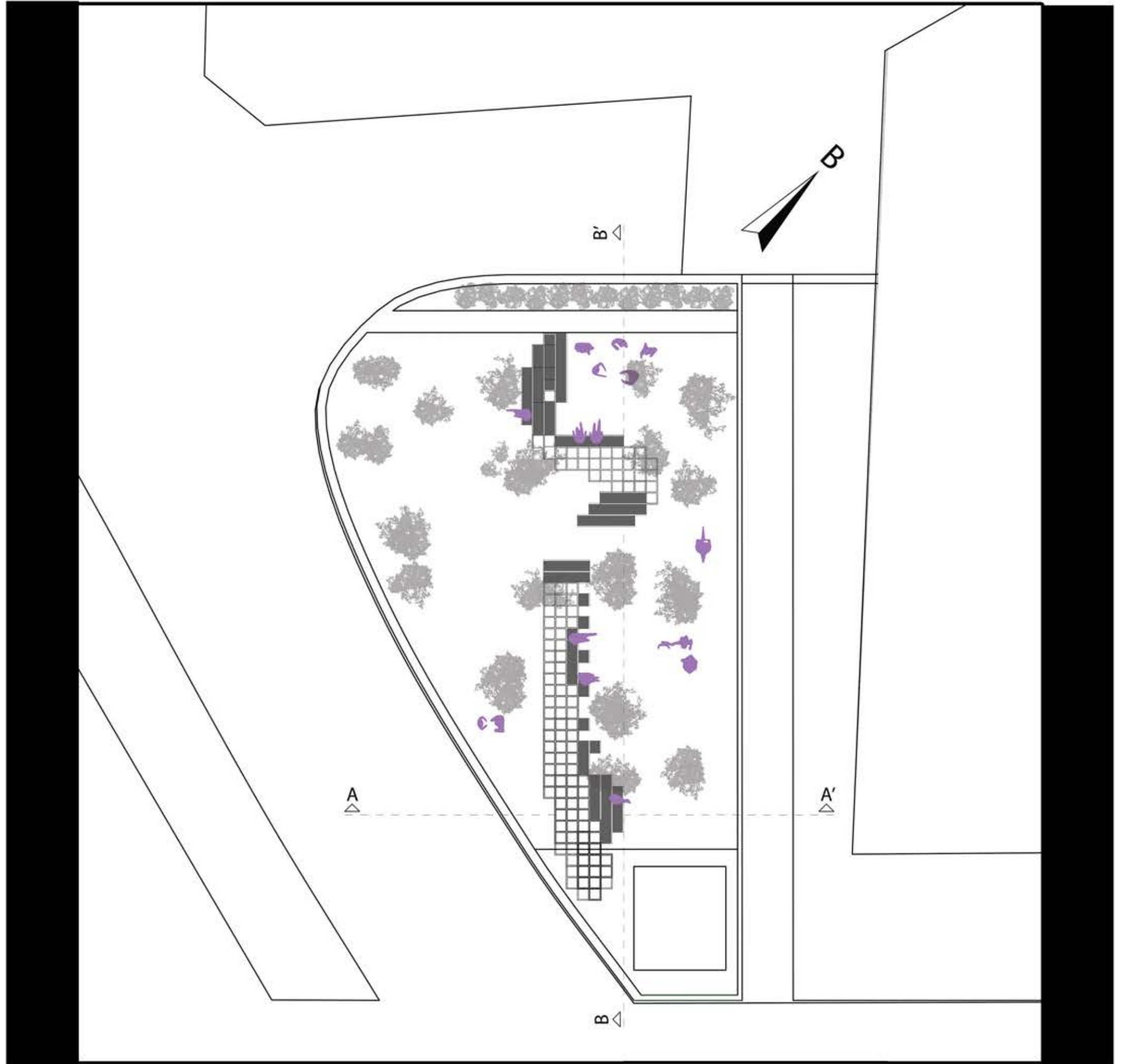

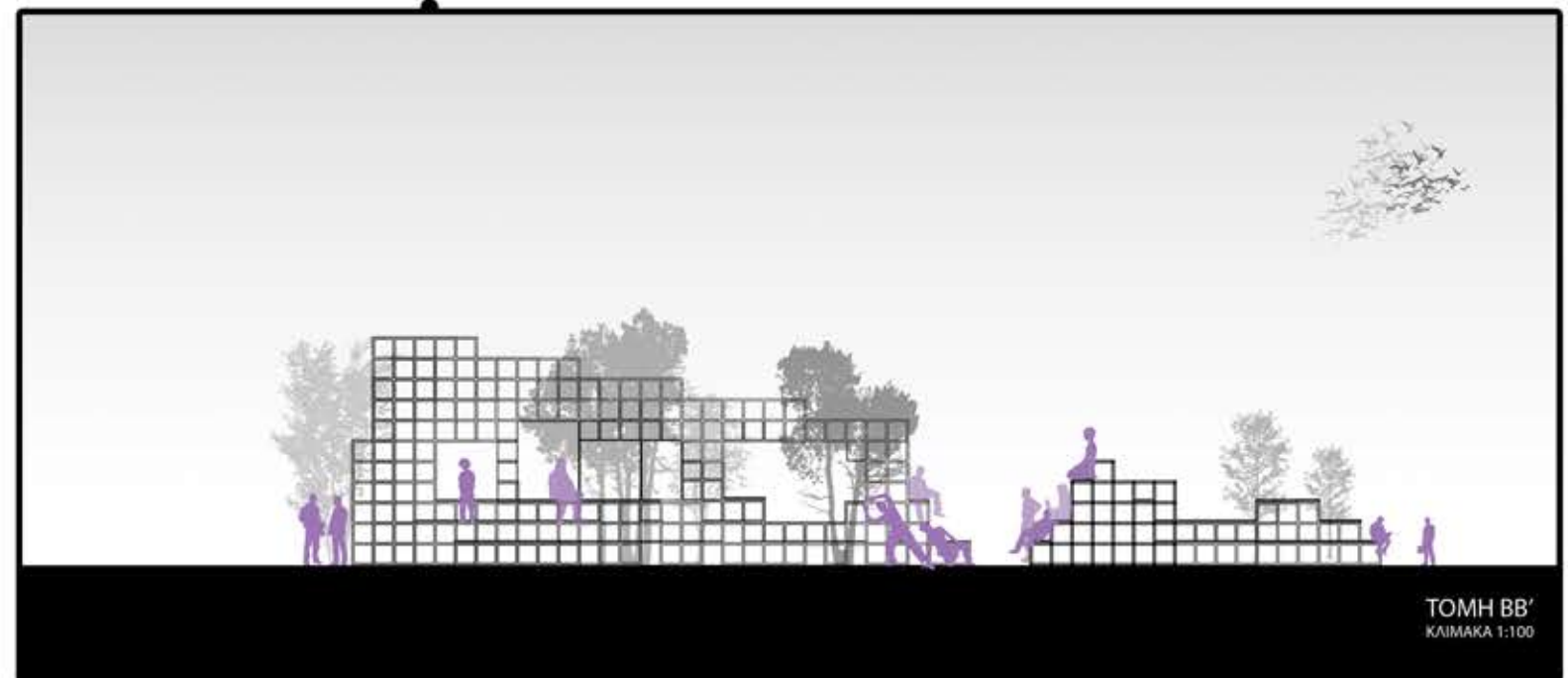
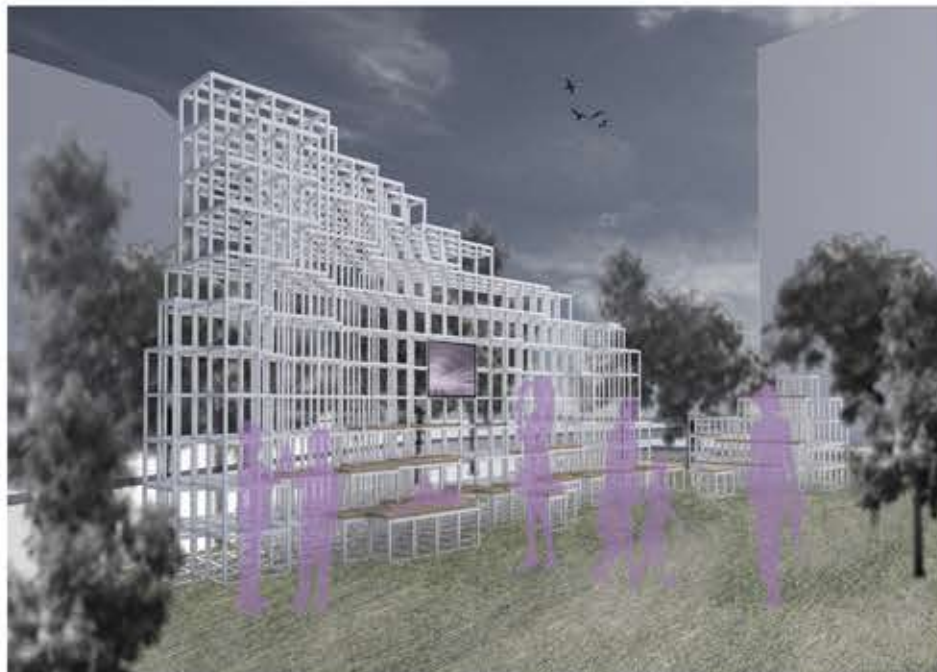
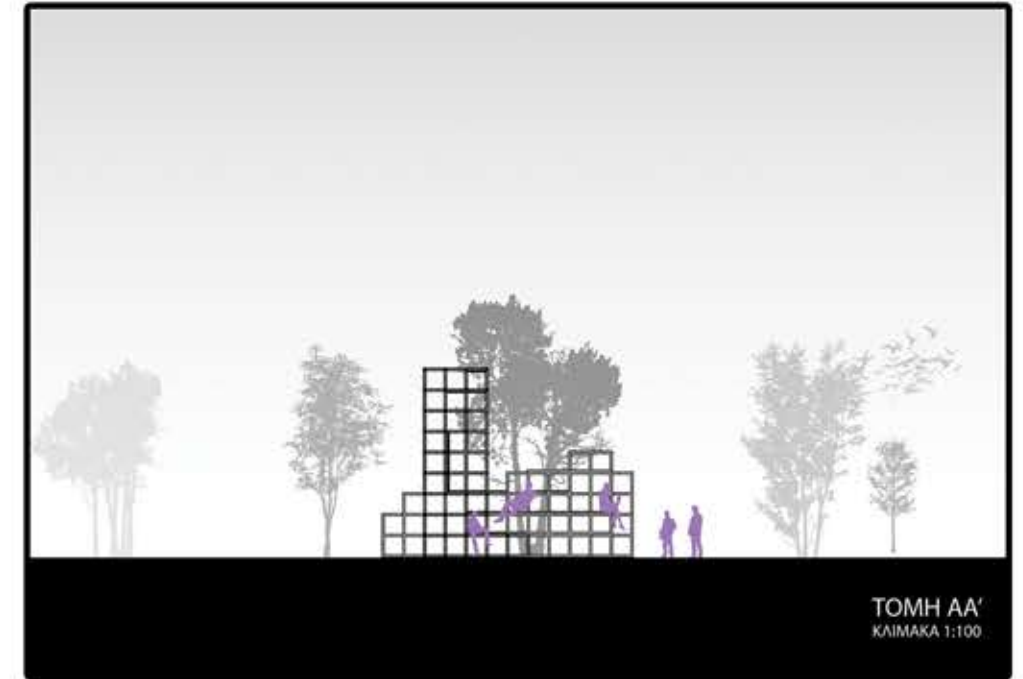
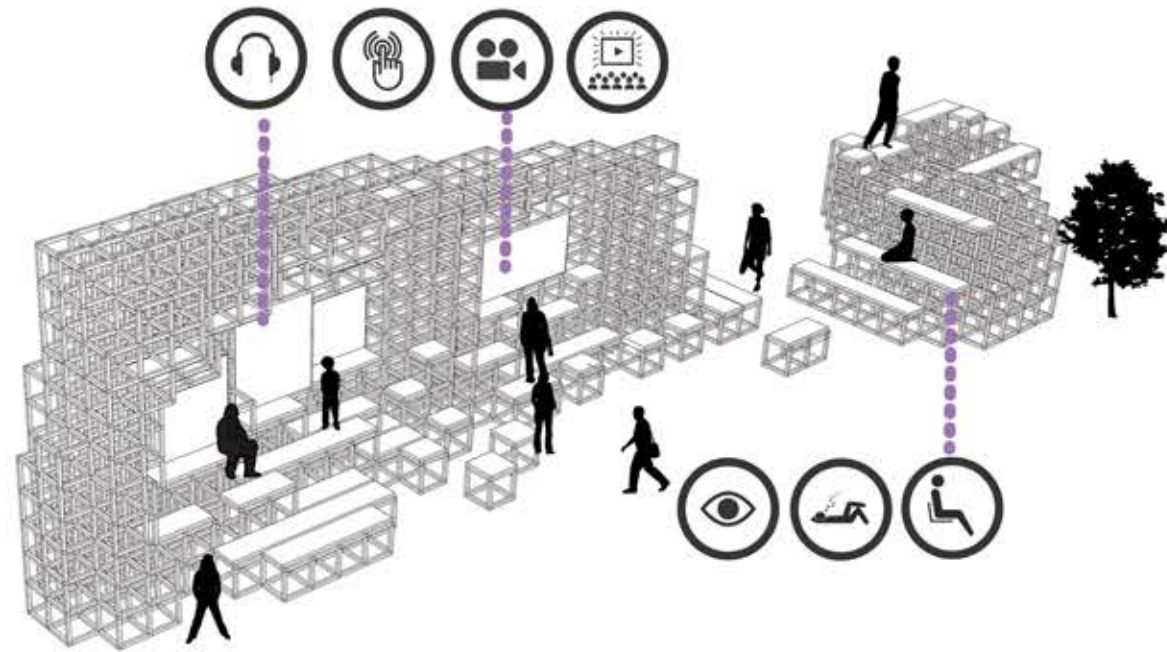
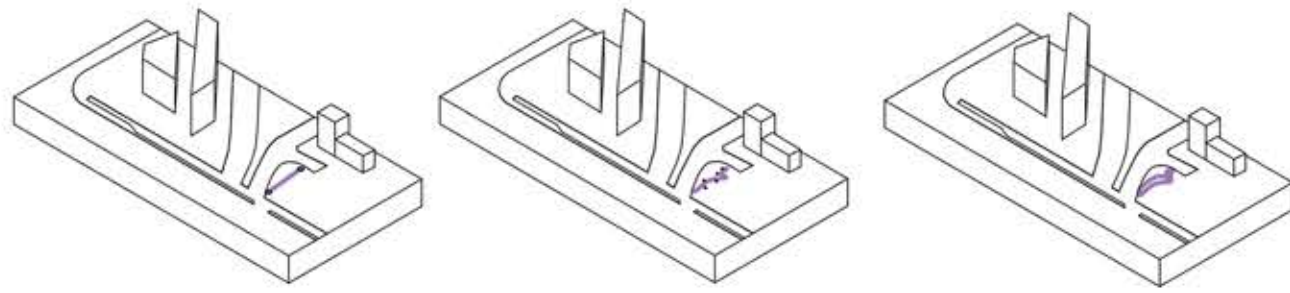

#9

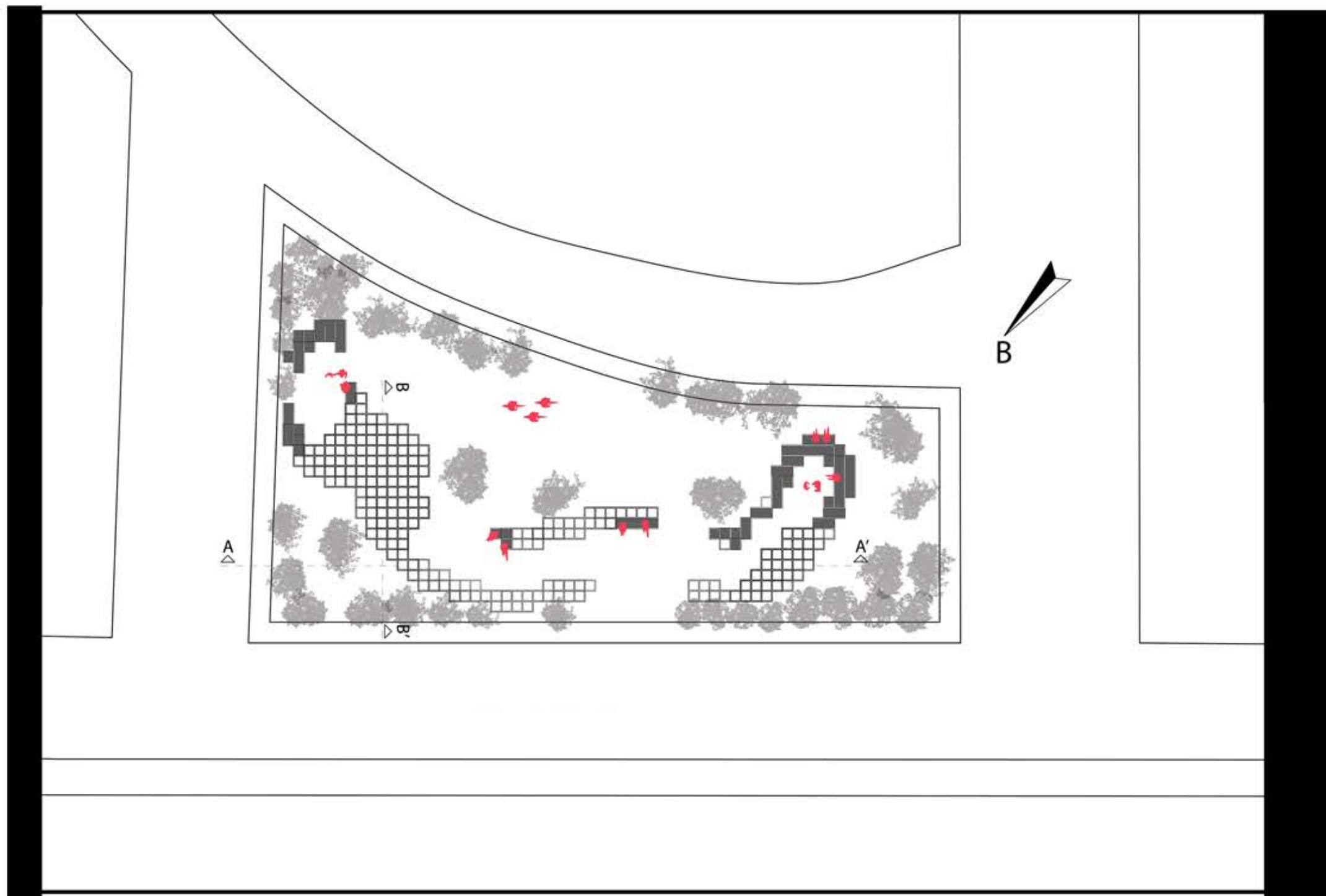

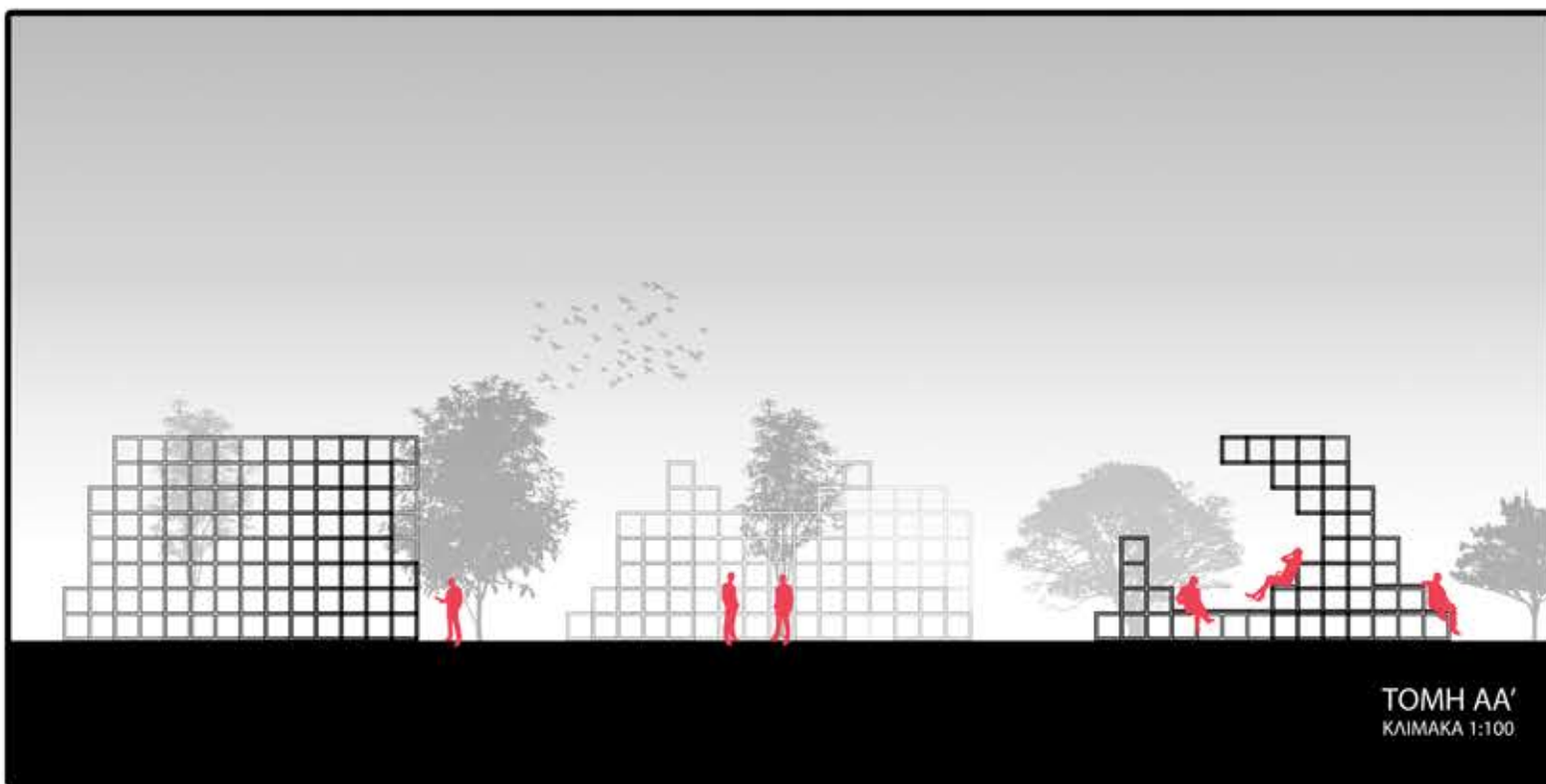
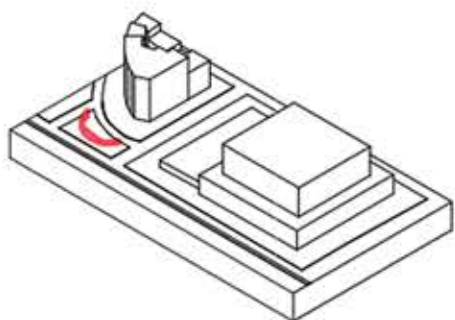
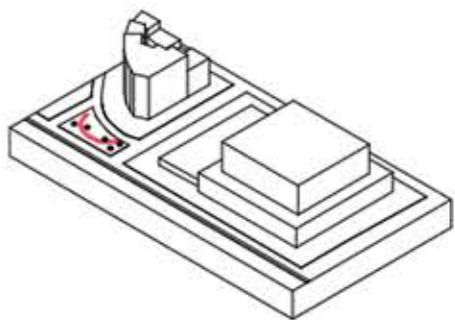
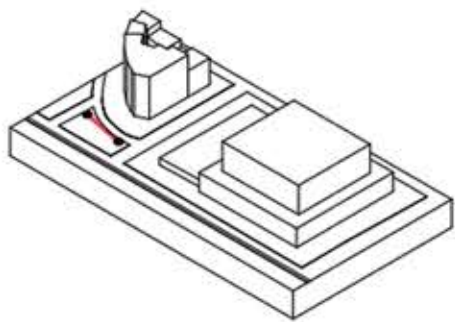

TOMH AA'
KAIMAKA 1:100

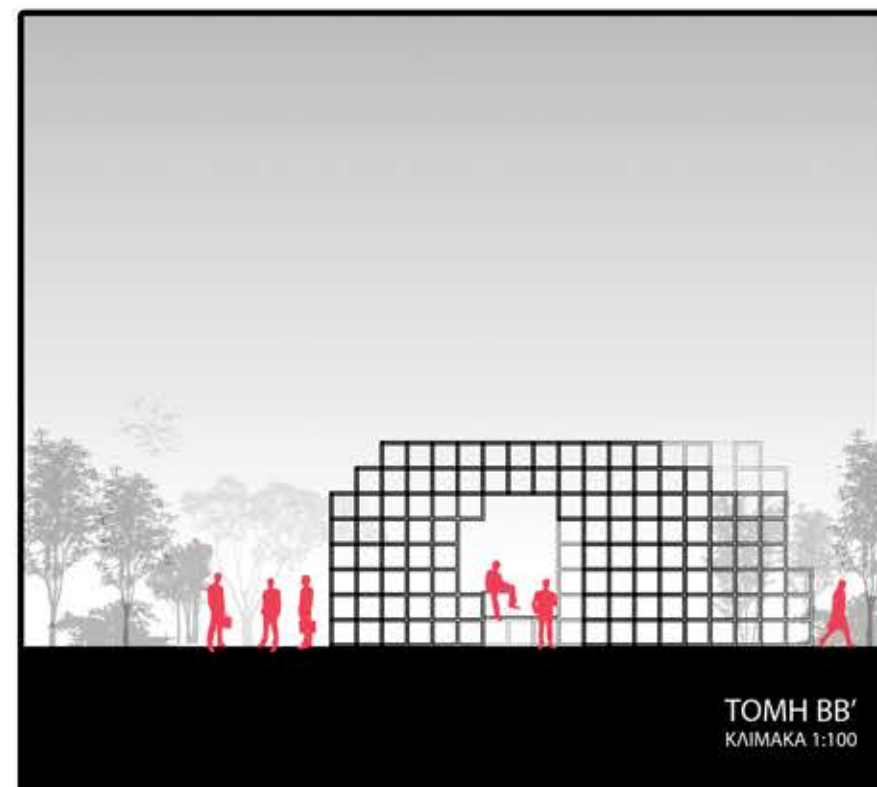

TOMH BB'
KAIMAKA 1:100

