



ΕΘΝΙΚΟ ΜΕΤΣΟΒΙΟ ΠΟΛΥΤΕΧΝΕΙΟ

ΣΧΟΛΗ ΗΛΕΚΤΡΟΛΟΓΩΝ ΜΗΧΑΝΙΚΩΝ ΚΑΙ ΜΗΧΑΝΙΚΩΝ ΥΠΟΛΟΓΙΣΤΩΝ  
ΤΟΜΕΑΣ ΗΛΕΚΤΡΙΚΩΝ ΒΙΟΜΗΧΑΝΙΚΩΝ ΔΙΑΤΑΞΕΩΝ ΚΑΙ ΣΥΣΤΗΜΑΤΩΝ ΑΠΟΦΑΣΕΩΝ

Επίδοση εναλλακτικών μεθόδων πρόβλεψης της τιμής της  
ενέργειας και η επίδραση της μεταφοράς μάθησης:  
Ευρήματα από την Κεντρική Ευρώπη

ΔΙΠΛΩΜΑΤΙΚΗ ΕΡΓΑΣΙΑ

Αύφαντόπουλος Ηλίας

Επιβλέπων: Μαρινάκης Ευάγγελος, Επίκουρος Καθηγητής Ε.Μ.Π

Αθήνα, Ιούλιος 2024



ΕΘΝΙΚΟ ΜΕΤΣΟΒΙΟ ΠΟΛΥΤΕΧΝΕΙΟ

ΣΧΟΛΗ ΗΛΕΚΤΡΟΛΟΓΩΝ ΜΗΧΑΝΙΚΩΝ ΚΑΙ ΜΗΧΑΝΙΚΩΝ ΥΠΟΛΟΓΙΣΤΩΝ  
ΤΟΜΕΑΣ ΗΛΕΚΤΡΙΚΩΝ ΒΙΟΜΗΧΑΝΙΚΩΝ ΔΙΑΤΑΞΕΩΝ ΚΑΙ ΣΥΣΤΗΜΑΤΩΝ ΑΠΟΦΑΣΕΩΝ

**Performance of Alternative Electricity Price Forecasting  
Methods and the impact of Transfer Learning:  
Findings from Central Europe**

THESIS

Ayfantopoulos Ilias

Supervisor: Marinakis Evangelos, NTUA Assistant Professor

Athens, July 2024





## ΕΘΝΙΚΟ ΜΕΤΣΟΒΙΟ ΠΟΛΥΤΕΧΝΕΙΟ

ΣΧΟΛΗ ΗΛΕΚΤΡΟΛΟΓΩΝ ΜΗΧΑΝΙΚΩΝ ΚΑΙ ΜΗΧΑΝΙΚΩΝ ΥΠΟΛΟΓΙΣΤΩΝ  
ΤΟΜΕΑΣ ΗΛΕΚΤΡΙΚΩΝ ΒΙΟΜΗΧΑΝΙΚΩΝ ΔΙΑΤΑΞΕΩΝ ΚΑΙ ΣΥΣΤΗΜΑΤΩΝ ΑΠΟΦΑΣΕΩΝ

Επίδοση εναλλακτικών μεθόδων πρόβλεψης της τιμής της  
ενέργειας και η επίδραση της μεταφοράς μάθησης:  
Ευρήματα από την Κεντρική Ευρώπη

### ΔΙΠΛΩΜΑΤΙΚΗ ΕΡΓΑΣΙΑ

Αύφαντόπουλος Ηλίας

Επιβλέπων: Μαρινάκης Ευάγγελος, Επίκουρος Καθηγητής Ε.Μ.Π  
Εγκρίθηκε από την τριμελή εξεταστική επιτροπή την ...η Ιουλίου 2024.

.....  
Ε.Μαρινάκης

.....  
Ι. Ψαρρας

.....  
Δ.Ασκούνης

Αθήνα, Ιούλιος 2024



.....  
**Αϋφαντόπουλος Ηλίας**

Διπλωματούχος Ηλεκτρολόγος Μηχανικός και Μηχανικός Υπολογιστών Ε.Μ.Π.

**Copyright © 2024 Αϋφαντόπουλος Ηλίας**

Με επιφύλαξη παντός δικαιώματος. All rights reserved.

Απαγορεύεται η αντιγραφή, αποθήκευση και διανομή της παρούσας εργασίας, εξ ολοκλήρου ή τμήματός αυτής, για εμπορικό σκοπό. Επιτρέπεται η ανατύπωση, αποθήκευση και διανομή για σκοπό μη κερδοσκοπικό, εκπαιδευτικής ή ερευνητικής φύσης, υπό την προϋπόθεση να αναφέρεται η πηγή προσέλευσης και να διατηρείται το παρόν μήνυμα. Ερωτήματα που αφορούν τη χρήση της εργασίας για κερδοσκοπικό σκοπό πρέπει να απευθύνονται προς τον συγγραφέα. Οι απόψεις και τα συμπεράσματα που περιέχονται σε αυτό το έγγραφο εκφράζουν τον συγγραφέα και δεν πρέπει να ερμηνευθεί ότι αντιπροσωπευουν τις επίσημες θέσεις του Εθνικού Μετσόβειου Πολυτεχνείου.

## Περίληψη

Αυτή η διατριβή διερευνά την απόδοση διαφόρων μοντέλων πρόβλεψης τιμών ηλεκτρικής ενέργειας και αξιολογεί τον αντίκτυπο της μεταφοράς μάθησης. Η μελέτη επικεντρώνεται στις αγορές ηλεκτρικής ενέργειας της Κεντρικής Ευρώπης, αναλύοντας δεδομένα από το 2019 έως το 2021. Χρησιμοποιήθηκαν επτά μοντέλα πρόβλεψης: Autoregressive with Exogenous variables (ARX), k-Nearest Neighbors (kNN), Regression Tree, Random Forest Regression (RFR), Support Vector Regression (SVR), Artificial Neural Network - Multi-Layer Perceptron (ANN-MLP), και Long Short-Term Memory (LSTM) networks, τα οποία αξιολογήθηκαν με χρήση των Μετρικών Μέσου Απόλυτου Σφάλματος (MAE), Ρίζας Μέσου Τετραγωνικού Σφάλματος (RMSE) και Συμμετρικού Μέσου Απόλυτου Ποσοστιαίου Σφάλματος (sMAPE).

Το μοντέλο ANN-MLP με clustering ξεπέρασε σταθερά τα άλλα μοντέλα σε όλες τις μετρικές. Η μελέτη εξέτασε επίσης την επίδραση σημαντικών γεωπολιτικών γεγονότων, όπως η σύγκρουση Ουκρανίας-Ρωσίας και η ενεργειακή κρίση, στην απόδοση των μοντέλων. Τα αποτελέσματα δείχνουν αυξημένα σφάλματα πρόβλεψης κατά τη διάρκεια αυτών των περιόδων, υποδηλώνοντας την πρόκληση της διατήρησης της ακρίβειας εν μέσω της αστάθειας της αγοράς.

Η μεταφοράς μάθησης έδειξε ότι, ενώ η αξιοποίηση προεκπαιδευμένων μοντέλων από συναφή σύνολα δεδομένων δεν παράγει πάντα τις χαμηλότερες μετρικές σφάλματος, παρέχει ανταγωνιστικά αποτελέσματα σε συντομότερο χρονικό διάστημα. Αυτό το εύρημα υπογραμμίζει το δυναμικό της μεταφοράς μάθησης για τη βελτίωση της αποδοτικότητας της πρόβλεψης.

Η διατριβή καταλήγει συζητώντας τις επιπτώσεις αυτών των ευρημάτων και προτείνοντας μελλοντικές κατευθύνσεις έρευνας, όπως της ενσωμάτωσης επιπλέον εξωγενών μεταβλητών, της ανάπτυξης υβριδικών

μοντέλων και της βελτίωσης της ερμηνευσιμότητας των μοντέλων.

**Λέξεις-κλειδιά:** Πρόβλεψη τιμών ηλεκτρικής ενέργειας, μηχανική μάθηση, ANN-MLP, μεταφορά μάθησης, γεωπολιτικά γεγονότα, υβριδικά μοντέλα, ENTSOE.



## Abstract

This thesis investigates the performance of various electricity price forecasting models and evaluates the impact of transfer learning on forecasting accuracy. The study focuses on the electricity markets of Germany, Belgium, and the Netherlands, analyzing data from 2019 to 2021. Seven forecasting models were employed: Autoregressive with Exogenous variables (ARX), k-Nearest Neighbors (kNN), Regression Tree, Random Forest Regression (RFR), Support Vector Regression (SVR), Artificial Neural Network - Multi-Layer Perceptron (ANN-MLP), and Long Short-Term Memory (LSTM) networks. These models were evaluated using Mean Absolute Error (MAE), Root Mean Square Error (RMSE), and Symmetric Mean Absolute Percentage Error (sMAPE).

The ANN-MLP model with clustering consistently outperformed other models across all metrics. The study also examined the impact of significant geopolitical events, such as the Ukraine-Russia conflict and the energy crisis, on model performance. Results indicate increased prediction errors during these periods, highlighting the challenge of maintaining accuracy amidst market volatility.

Transfer learning experiments demonstrated that while leveraging pre-trained models from related datasets does not always produce the lowest error metrics, it provides competitive results in a shorter time frame. This finding underscores the potential of transfer learning to enhance forecasting efficiency.

The thesis concludes by discussing the implications of these findings and suggesting future research directions, including the integration of additional exogenous variables, development of hybrid models, and improvement of model interpretability.

**Keywords:** Electricity price forecasting, machine learning, ANN-MLP, clustering, transfer learning, geopolitical events, hybrid models, ENTSOE.

# Contents

<b>1</b>	<b>Introduction</b>	<b>20</b>
1.1	Background and Context . . . . .	20
1.1.1	Electricity Market Dynamics . . . . .	20
1.1.2	Importance of Electricity Price Forecasting . . . . .	20
1.2	Challenges in Electricity Price Forecasting . . . . .	21
1.2.1	Price Volatility . . . . .	21
1.2.2	Data Complexity . . . . .	22
1.2.3	Modeling Limitations . . . . .	23
1.3	Review of Traditional Forecasting Methods . . . . .	23
1.3.1	Statistical Models . . . . .	23
1.3.2	Early Machine Learning Approaches . . . . .	24
1.3.3	Limitations of Traditional Methods . . . . .	25
1.4	Emergence of Alternative Forecasting Approaches . . . . .	26
1.4.1	Hybrid Models . . . . .	26
1.4.2	Memory-Based Models . . . . .	26
1.4.3	Fractal Approaches . . . . .	27
1.4.4	Enhanced Computational Techniques . . . . .	27
1.5	Research Gap and Thesis Contribution . . . . .	28
1.5.1	Identified Gaps . . . . .	28
1.5.2	Thesis Objectives . . . . .	28
1.5.3	Expected Contributions . . . . .	29
1.5.4	Scientific Contribution . . . . .	30
1.6	Thesis Structure . . . . .	30
<b>2</b>	<b>Literature Review</b>	<b>32</b>

2.1	Statistical Models . . . . .	34
2.2	Volatility Models . . . . .	34
2.3	Challenges and Limitations . . . . .	34
2.4	Early Machine Learning Approaches . . . . .	35
2.4.1	Introduction of Neural Networks . . . . .	35
2.4.2	Radial Basis Function Networks and Multilayer Perceptrons . . . . .	36
2.4.3	Support Vector Machines (SVM) . . . . .	36
2.4.4	Challenges and Adaptations . . . . .	36
2.4.5	Shift Towards Hybrid and Advanced ML Models . . . . .	37
2.5	Advanced Approaches and Deep Learning . . . . .	37
2.5.1	Deep Learning in EPF . . . . .	38
2.5.2	Hybrid Models . . . . .	38
2.5.3	Challenges and Opportunities . . . . .	38
2.5.4	Future Directions . . . . .	39
2.6	Alternative Approaches . . . . .	39
2.6.1	Fractal Approaches . . . . .	40
2.6.2	Memory-Based Models . . . . .	40
2.6.3	Hybrid and Ensemble Techniques . . . . .	41
2.6.4	Challenges and Future Research Directions . . . . .	41
2.7	Performance Across Markets . . . . .	42
2.8	Influence of Data Availability and Quality . . . . .	42
2.9	Model Complexity vs. Interpretability . . . . .	43
2.10	Adaptation to Market Dynamics . . . . .	43
2.11	Future Directions and Challenges . . . . .	43
2.12	Research Gaps and Future Directions . . . . .	44
2.12.1	Integration of Renewable Energy Sources . . . . .	44
2.12.2	Advanced Machine Learning Techniques . . . . .	45

2.12.3	Model Interpretability and Trust . . . . .	45
2.12.4	Real-time Data Processing and Forecasting . . . . .	45
2.12.5	Cross-Market Dynamics and Transfer Learning . . . . .	46
2.12.6	Standardization of Evaluation Frameworks . . . . .	46
2.12.7	Conclusion . . . . .	46
<b>3</b>	<b>Methodology</b>	<b>47</b>
3.1	Overview . . . . .	47
3.2	Data Collection . . . . .	48
3.3	Data Processing and Preparation . . . . .	49
3.3.1	Handling Missing Data . . . . .	49
3.3.2	Data Aggregation and Timeframe Standardization . . . . .	49
3.4	Data Description . . . . .	50
<b>4</b>	<b>Implementation</b>	<b>53</b>
4.1	Model Selection . . . . .	53
4.2	Model Implementation . . . . .	54
4.2.1	ARX (Autoregressive Model with Exogenous Variables) . . . . .	54
4.2.2	k-Nearest Neighbors (kNN) . . . . .	56
4.2.3	Regression Tree . . . . .	58
4.2.4	Random Forest Regression . . . . .	60
4.2.5	Support Vector Regression (SVR) . . . . .	62
4.2.6	Artificial Neural Network (ANN) for Electricity Price Forecasting . . . . .	64
4.2.7	Long Short-Term Memory Network (LSTM) . . . . .	67
4.2.8	Transfer Learning . . . . .	69
4.3	Evaluation Metrics . . . . .	71

<b>5</b>	<b>Data Analysis, Results, Conclusion</b>	<b>72</b>
5.1	Descriptive Statistics . . . . .	72
5.2	Comparative Descriptive Diagrams . . . . .	76
5.2.1	Day-ahead Total Load Forecast and Actual Total Load . . . . .	76
5.2.2	Wind Onshore and Offshore Forecast and Actual Aggregated . . . . .	77
5.2.3	Solar Forecast and Actual Aggregated . . . . .	78
5.2.4	Day-ahead Price . . . . .	79
5.3	Results and Conclusions . . . . .	85
5.4	Results . . . . .	86
5.4.1	Model Performance and Metrics . . . . .	86
5.4.2	Geopolitical Events and Market Dynamics . . . . .	89
5.4.3	Transfer Learning Results . . . . .	91
5.5	Conclusion . . . . .	93
<b>6</b>	<b>Discussion and Future Work</b>	<b>94</b>
6.1	Implications of Findings . . . . .	94
6.2	Limitations and Challenges . . . . .	94
6.3	Future Research Directions . . . . .	95
6.4	Conclusion . . . . .	96

## List of Figures

1	Overview of the Methodology . . . . .	52
2	k Nearest Neighbours Descriptive [24] . . . . .	57
3	Random Forest Regressor Descriptive [28] . . . . .	61
4	Support Vector Regressor Descriptive [29] . . . . .	63
5	Artificial Neural Networks Descriptive [25] . . . . .	66
6	MLP Descriptive [27] . . . . .	66
7	Long Short Term Memory Descriptive [26] . . . . .	68
8	Transfer Learning Descriptive [30] . . . . .	70
9	Germany: quarterly average Day-ahead total Load Forecast [MWh] .	80
10	Germany: quarterly average Actual Total Load [MWh] . . . . .	80
11	Belgium: hourly average Day-ahead total Load Forecast [MWh] . . .	80
12	Belgium: hourly average Actual Total Load [MWh] . . . . .	80
13	Netherlands: hourly average Day-ahead total Load Forecast [MWh] .	80
14	Netherlands: hourly average Actual Total Load [MWh] . . . . .	80
15	Germany: quarterly average Wind Offshore Forecast [MWh] . . . . .	81
16	Germany: quarterly average Wind Offshore Actual [MWh] . . . . .	81
17	Belgium: hourly average Wind Offshore Forecast [MWh] . . . . .	81
18	Belgium: hourly average Wind Offshore Actual [MWh] . . . . .	81
19	Netherlands: hourly average Wind Offshore Forecast [MWh] . . . . .	81
20	Netherlands: hourly average Wind Offshore Actual [MWh] . . . . .	81
21	Germany: quarterly average Wind Onshore Forecast [MWh] . . . . .	82
22	Germany: quarterly average Wind Onshore Actual [MWh] . . . . .	82
23	Belgium: hourly average Wind Onshore Forecast [MWh] . . . . .	82
24	Belgium: hourly average Wind Onshore Actual [MWh] . . . . .	82
25	Netherlands: hourly average Wind Onshore Forecast [MWh] . . . . .	82

26	Netherlands: hourly average Wind Onshore Actual [MWh] . . . . .	82
27	Germany: quarterly average Solar Forecast Production [MWh] . . . . .	83
28	Germany: quarterly average Solar Actual Production [MWh] . . . . .	83
29	Belgium: hourly average Solar Forecast Production [MWh] . . . . .	83
30	Belgium: hourly average Solar Actual Production [MWh] . . . . .	83
31	Netherlands: hourly average Solar Forecast Production [MWh] . . . . .	83
32	Netherlands: hourly average Solar Actual Production [MWh] . . . . .	83
33	Germany: quarterly average Day-ahead Price [EUR/MWh] . . . . .	84
34	Belgium: hourly average Day-ahead Price [EUR/MWh] . . . . .	84
35	Netherlands: hourly average Day-ahead Price [EUR/MWh] . . . . .	84
36	Mean Absolute Error (MAE) for ANN-MLP Clustered Approach . . . . .	87
37	Root Mean Square Error (RMSE) for ANN-MLP Clustered Approach . . . . .	87
38	Symmetric Mean Absolute Percentage Error (sMAPE) for ANN-MLP Clustered Approach . . . . .	88

## List of Tables

1	Germany: Descriptive Statistics (Values in columns marked with * are in $10^3$ GWh) . . . . .	73
2	Belgium: Descriptive Statistics (Values in columns marked with * are in $10^3$ GWh) . . . . .	74
3	Netherlands: Descriptive Statistics (Values in columns marked with * are in $10^3$ GWh) . . . . .	75
4	Performance Metrics Pivot Table . . . . .	86
5	Performance Metrics for Transfer Learning Experiments . . . . .	92

## Ευρεία Περίληψη

Η πρόβλεψη τιμών ηλεκτρικής ενέργειας (EPF) αποτελεί κρίσιμο εργαλείο στη λειτουργία των απελευθερωμένων αγορών ηλεκτρικής ενέργειας, βοηθώντας στη βελτιστοποίηση της οικονομικής αποδοτικότητας και της σταθερότητας του δικτύου. Η παρούσα διπλωματική εργασία επικεντρώνεται στην αξιολόγηση διαφόρων μοντέλων πρόβλεψης τιμών ηλεκτρικής ενέργειας, καθώς και στην εφαρμογή μεθόδων μεταφοράς μάθησης για τη βελτίωση της ακρίβειας των προβλέψεων.

## Μοντέλα Πρόβλεψης

Τα μοντέλα που εξετάστηκαν περιλαμβάνουν:

- Αυτοπαλίνδρομα με Εξωγενείς Μεταβλητές (ARX)
- k-nearest Neighbors (kNN)
- Τυχαία Δάση Παλινδρόμησης (RFR)
- Δέντρα Παλινδρόμησης
- Υποστήριξη Διανυσματικής Παλινδρόμησης (SVR)
- Τεχνητά Νευρωνικά Δίκτυα - Πολυεπίπεδη Περσεπτρόνια (ANN-MLP)
- Δίκτυα Μακροχρόνιας Βραχυπρόθεσμης Μνήμης (LSTM)

Τα δεδομένα που χρησιμοποιήθηκαν προέρχονται από την Πλατφόρμα Διαφάνειας του ENTSO-E για τη Γερμανία, το Βέλγιο και την Ολλανδία κατά την περίοδο 2019-2021. Η αξιολόγηση της απόδοσης των μοντέλων έγινε με χρήση μετρικών όπως το Μέσο Απόλυτο Σφάλμα (MAE), το Τετραγωνικό



Μέσο Σφάλμα (RMSE) και το Συμμετρικό Μέσο Απόλυτο Ποσοστιαίο Σφάλμα (sMAPE).

## **Αποτελέσματα**

Η ανάλυση των αποτελεσμάτων έδειξε ότι το μοντέλο ANN-MLP με τη χρήση clustering είχε την καλύτερη απόδοση μεταξύ των εξεταζόμενων μοντέλων. Τα ευρήματα αυτά ευθυγραμμίζονται με τη βιβλιογραφία, η οποία υποδεικνύει την αποτελεσματικότητα των βαθιών νευρωνικών δικτύων στην πρόβλεψη πολύπλοκων και μη γραμμικών σχέσεων.

## **Γεωπολιτικά Γεγονότα και Επιπτώσεις στην Αγορά**

Κατά την περίοδο της μελέτης, σημαντικά γεωπολιτικά γεγονότα, όπως η σύγκρουση Ουκρανίας-Ρωσίας, επηρέασαν δραματικά τις τιμές της ηλεκτρικής ενέργειας στην Ευρώπη. Η αυξημένη αστάθεια και αβεβαιότητα που προκλήθηκε από αυτές τις εξελίξεις δημιούργησε σημαντικές προκλήσεις για τα μοντέλα πρόβλεψης.

Η ανάλυση έδειξε ότι οι τιμές της ηλεκτρικής ενέργειας παρουσίασαν σημαντική αύξηση της μεταβλητότητας κατά την έναρξη του 2021, γεγονός που επηρέασε την ακρίβεια των προβλέψεων των μοντέλων. Τα ευρήματα αυτά αναδεικνύουν την ανάγκη για μοντέλα πρόβλεψης που μπορούν να προσαρμόζονται δυναμικά στις μεταβαλλόμενες συνθήκες της αγοράς.

## **Μεταφορά Μάθησης**

Η μεταφορά μάθησης αξιολογήθηκε ως στρατηγική για τη βελτίωση της ακρίβειας των προβλέψεων σε διαφορετικές αγορές. Τα αποτελέσματα έδειξαν

ότι η μεταφορά μάθησης μπορεί να προσφέρει οφέλη, ιδίως στη μείωση του sMAPE, και επιτυγχάνει σχεδόν εξίσου καλά αποτελέσματα όσον αφορά το MAE και το RMSE. Παράλληλα, επισημαίνεται η μείωση του χρόνου εκπαίδευσης, καθιστώντας τη μεταφορά μάθησης μια πρακτική και αποτελεσματική επιλογή.

## Συμπεράσματα και Προτάσεις για Μελλοντική Έρευνα

Η έρευνα αυτή αναδεικνύει τη δυνατότητα των προχωρημένων μοντέλων μηχανικής μάθησης, και ειδικότερα του μοντέλου ANN-MLP με clustering, στην ακριβή πρόβλεψη των τιμών της ηλεκτρικής ενέργειας. Παρά τις προκλήσεις που προέκυψαν από τα γεωπολιτικά γεγονότα, τα μοντέλα επέδειξαν ισχυρή απόδοση, υπογραμμίζοντας την ανάγκη για συνεχή βελτίωση και προσαρμογή των τεχνικών πρόβλεψης.

Οι προτάσεις για μελλοντική έρευνα περιλαμβάνουν:

- Βελτίωση των τεχνικών μεταφοράς μάθησης με τη χρήση μεθόδων προσαρμογής τομέα και πολυκατακτικής μάθησης.
- Ενσωμάτωση επιπλέον εξωγενών μεταβλητών, όπως γεωπολιτικοί δείκτες, οικονομικοί δείκτες και πρόγνωση καιρού.
- Ανάπτυξη υβριδικών μοντέλων που συνδυάζουν τη δύναμη διαφόρων τεχνικών μηχανικής μάθησης και στατιστικών μεθόδων.
- Υλοποίηση συστημάτων πρόβλεψης σε πραγματικό χρόνο που μπορούν να προσαρμόζονται δυναμικά στα νέα δεδομένα.
- Βελτίωση της ερμηνευσιμότητας των μοντέλων μηχανικής μάθησης για

την αύξηση της εμπιστοσύνης και της αποδοχής από τους ενδιαφερόμενους φορείς.

- Μελέτη των επιπτώσεων της ενσωμάτωσης των ανανεώσιμων πηγών ενέργειας στις δυναμικές των τιμών ηλεκτρικής ενέργειας.

Η πρόοδος στις τεχνικές μηχανικής μάθησης και ανάλυσης χρονοσειρών προσφέρει σημαντικές ευκαιρίες για τη βελτίωση της πρόβλεψης τιμών ηλεκτρικής ενέργειας. Με την αξιοποίηση των ευρημάτων της βιβλιογραφίας και των πειραματικών μας ευρημάτων, μπορούμε να συνεχίσουμε να βελτιώνουμε και να ενισχύουμε τα μοντέλα πρόβλεψης, συμβάλλοντας σε πιο αποδοτικές και αξιόπιστες αγορές ενέργειας.

# 1 Introduction

## 1.1 Background and Context

### 1.1.1 Electricity Market Dynamics

The landscape of electricity markets has undergone significant transformations over the past few decades, marked notably by the shift from regulated monopolies to deregulated market structures. This transition has been driven by the belief that competition fosters efficiency, leading to lower prices and improved service quality for consumers. Deregulation introduced a wholesale electricity market where regulatory bodies do not set prices but are determined by supply and demand dynamics.

The deregulated electricity market is characterized by its distinct segments: generation, transmission, distribution, and retail. In this market structure, electricity producers compete to sell their generated power in a wholesale market, while retail energy suppliers purchase this power to sell to consumers and businesses. The competitive nature of these markets has led to the development of various financial instruments, such as futures and options, allowing market participants to hedge against price volatility.

### 1.1.2 Importance of Electricity Price Forecasting

Forecasting electricity prices has become increasingly critical in deregulated markets for several reasons. First, it enables power-generating companies to make informed decisions regarding the dispatch of their generation assets, operational planning, and maintenance schedules. For consumers and retail suppliers, accurate price forecasts are crucial for budget planning and choosing the optimal mix of fixed and spot market purchasing to minimize costs.

Moreover, electricity price forecasting plays a pivotal role in energy trading.

Traders rely on forecasts to make buying and selling decisions in spot markets and to formulate strategies for derivative markets. Given the high volatility and unpredictability of electricity prices, driven by factors such as fluctuating demand, fuel prices, and unforeseen outages, accurate forecasting models are indispensable tools for mitigating financial risk and capitalizing on market opportunities.

The complexity of forecasting in this context arises from the unique characteristics of electricity as a commodity: it cannot be economically stored in large quantities, its demand is highly inelastic, and its production must constantly balance demand to maintain grid stability. These factors contribute to the electricity price's inherent volatility and present a substantial challenge for forecasting models.

## **1.2 Challenges in Electricity Price Forecasting**

### **1.2.1 Price Volatility**

Electricity markets are notorious for their price volatility, which can be attributed to the unique characteristics of electricity as a commodity. Unlike other goods, electricity must be produced and consumed simultaneously, making storage a costly and technically challenging option. This immediate necessity for balance between supply and demand leads to significant price fluctuations, influenced by a myriad of factors.

Demand variability is a primary driver of price volatility. Electricity consumption patterns are closely linked to human activity, weather conditions, and economic factors, leading to predictable daily and seasonal peaks but also unexpected spikes in demand. For instance, extreme weather conditions, such as heat waves or cold snaps, can cause sudden surges in demand due to increased use of heating or cooling systems.

Fuel prices also play a critical role in determining electricity prices, especially in markets heavily reliant on fossil fuels for electricity generation. Fluctuations in the

prices of coal, natural gas, or oil can directly impact electricity production costs, thereby affecting market prices.

The integration of renewable energy sources introduces additional variability. While beneficial for sustainability and energy independence, the variable nature of wind and solar power, dependent on weather and time of day, complicates the task of balancing the grid and can lead to erratic price movements.

Unexpected outages of power plants or transmission infrastructure further exacerbate price volatility. Such events can lead to sudden shortages in supply, prompting sharp price increases. Conversely, unanticipated dips in demand or overproduction from renewables can result in negative prices, where producers pay to offload excess electricity.

### **1.2.2 Data Complexity**

The complexity of electricity price data poses another significant challenge for forecasting. Characteristics such as non-linearity and non-stationarity reflect the market's dynamic nature but complicate modeling efforts. Prices can exhibit sudden spikes or drops, often referred to as price jumps, which are difficult to predict using standard statistical methods. These anomalies can arise from various market conditions, including bidding strategies of market participants, regulatory changes, or significant shifts in supply and demand.

Moreover, the presence of seasonal and weekly cycles adds to the data's complexity, requiring models to account for varying patterns of electricity usage throughout the year and on different days of the week. Traditional linear models and even some machine learning approaches struggle to capture these intricate patterns, especially when historical data exhibit changing trends over time.

### **1.2.3 Modeling Limitations**

Traditional forecasting models have faced limitations in accurately predicting electricity prices due to the aforementioned challenges. Linear regression models and time-series analyses like ARIMA are based on assumptions of linearity and stationarity, which are seldom met in the electricity market context. These models often fail to account for the market's non-linear responses to external factors and the inherent volatility of prices.

Furthermore, the predictive accuracy of conventional models is significantly challenged by extreme market events, such as regulatory changes, major outages, or sudden economic shifts. These events can lead to substantial forecasting errors, underscoring the need for more adaptable and sophisticated modeling techniques.

Given these challenges, there's a growing consensus among researchers and practitioners about the necessity to explore and develop alternative forecasting methods. These methods aim to better capture the complex, volatile nature of electricity prices, leveraging advancements in computational power, data analytics, and machine learning. The subsequent sections will review traditional forecasting methods and discuss the emergence of innovative approaches that promise to enhance the accuracy and reliability of electricity price forecasts.

## **1.3 Review of Traditional Forecasting Methods**

### **1.3.1 Statistical Models**

Historically, the foundation of electricity price forecasting has been laid by statistical models, with a particular emphasis on time series analysis. Among these, Autoregressive Integrated Moving Average (ARIMA) models have been prominently used. ARIMA models are capable of modeling a wide range of time series data with the

assumption of linearity and stationarity in the data. They work on the principle of describing the autocorrelations in the data, which has made them suitable for short-term forecasting where the price series exhibit regular patterns.

However, the electricity market's deregulation introduced complexities that often violate the underlying assumptions of ARIMA models. For instance, the non-stationary nature of electricity prices, characterized by sudden spikes or drops due to demand-supply imbalances, poses a significant challenge. Despite variations like Seasonal ARIMA (SARIMA) introduced to handle seasonality, the core limitations related to non-linear patterns and abrupt changes remain inadequately addressed.

Generalized Autoregressive Conditional Heteroskedasticity (GARCH) models emerged as an extension to capture the volatility clustering in time series data, a common feature in financial markets, including electricity. GARCH models account for varying variances over time, which is indicative of the periods of relative calm and turbulence in electricity prices. While GARCH models marked an improvement over ARIMA in handling volatility, their predictive performance in the face of extreme price jumps and the non-linear dynamics of the electricity market has been less than satisfactory.

### **1.3.2 Early Machine Learning Approaches**

The advent of machine learning brought about a new era in electricity price forecasting. Neural networks and their ability to model complex non-linear relationships without predefined equations offered a promising alternative. Multilayer Perceptrons (MLPs) and Radial Basis Function (RBF) networks have been applied to capture the intricate patterns in electricity prices. These models learn from historical data to predict future prices, adjusting their internal parameters to minimize forecasting errors.



Support Vector Machines (SVMs) have also been explored for their robustness in classification and regression tasks, including price forecasting. SVMs aim to find the optimal separation between data points of different categories (or values, in the case of regression) by maximizing the margin between them. This methodology, particularly with its kernel trick, allows the modeling of non-linear relationships in the data effectively.

Despite the advancements offered by neural networks and SVMs, their application in electricity price forecasting is not without challenges. The black-box nature of these models often leads to difficulties in interpretation and understanding of the model's decision-making process. Moreover, their performance is heavily dependent on the selection of hyperparameters, which requires extensive experimentation and domain knowledge.

### **1.3.3 Limitations of Traditional Methods**

The primary limitation across traditional forecasting methods, including both statistical models and early machine learning approaches, lies in their struggle to fully encapsulate the dynamics of deregulated electricity markets. Factors such as regulatory changes, market participant behavior, and the increasing integration of renewable energy sources introduce complexities that demand more adaptive and flexible modeling approaches.

Furthermore, the requirement for extensive historical data for accurate predictions poses a challenge in rapidly changing market conditions, where past patterns may not reliably indicate future trends. This has led to a growing interest in developing hybrid models and exploring novel machine-learning techniques that can better handle the multifaceted nature of electricity price data.

## 1.4 Emergence of Alternative Forecasting Approaches

### 1.4.1 Hybrid Models

The limitations of traditional forecasting methods in addressing the multifaceted nature of electricity price data have prompted researchers to explore hybrid models. These models synergize the predictive capabilities of different methodologies to enhance overall forecasting accuracy. A notable example is the integration of wavelet transforms with machine learning techniques. Wavelet-based decomposition aids in isolating the price series into more manageable sub-series, capturing distinct frequency components. This preprocessing significantly improves the model's ability to understand and predict complex patterns within the electricity price data [15, 16]. By combining statistical methods with advanced machine learning algorithms, hybrid models offer a balanced approach to capturing both linear and non-linear relationships inherent in the data, thus providing more reliable forecasts in volatile market conditions.

### 1.4.2 Memory-Based Models

Memory-based approaches, such as the k-Nearest Neighbors (k-NN) algorithm, have gained popularity for their simplicity and effectiveness in forecasting tasks. These models operate on the principle that historical data contains valuable insights that can be directly applied to predict future outcomes. By analyzing past instances that closely resemble the current market situation, memory-based models can generate predictions without the need for explicit model formulations [17]. This approach is particularly adept at handling the seasonality and recurring anomalies within the electricity price series, offering an adaptable framework that remains effective even as market dynamics evolve. The work by Papalexopoulos and Hesterberg [18] underscores the potential of memory-based models in capturing temporal dependencies and

patterns in electricity prices, illustrating their practicality in real-world forecasting scenarios.

### **1.4.3 Fractal Approaches**

Fractal theory introduces a novel perspective in modeling financial time series, including electricity prices, by exploiting the self-similar patterns within the data. Mandelbrot's pioneering work on fractals has laid the foundation for applying fractal geometry to financial markets, suggesting that price movements exhibit fractal characteristics [6]. In the context of electricity price forecasting, fractal models seek to identify and leverage these repeating patterns at various scales, offering insights into the underlying market dynamics. Fractal approaches, such as those explored by Serletis and Andreadis [19], aim to model the complexity and irregularities in electricity prices, revealing deep-seated structures that traditional linear models often overlook. However, the implementation of fractal models in electricity markets is still in its infancy, with ongoing research focused on refining these methods to enhance their predictive performance and computational efficiency.

### **1.4.4 Enhanced Computational Techniques**

The advent of deep learning has marked a significant milestone in the evolution of forecasting methodologies. Deep learning models, particularly Recurrent Neural Networks (RNNs) and Long Short-Term Memory (LSTM) networks, have demonstrated remarkable success in capturing the temporal dynamics of time series data. Their ability to process sequential information over extended periods makes them well-suited for electricity price forecasting, where long-term dependencies and seasonal trends play a crucial role [20, 21]. The application of deep learning in this domain is not without challenges, particularly concerning model interpretability and the need

for large datasets. Nevertheless, the empirical success of these models in various forecasting competitions and studies highlights their potential to redefine the accuracy benchmarks in electricity price forecasting.

## **1.5 Research Gap and Thesis Contribution**

### **1.5.1 Identified Gaps**

The exploration of electricity price forecasting methodologies reveals critical gaps in the literature, particularly regarding the adaptability and interpretability of existing models amidst the evolving dynamics of deregulated electricity markets. Studies have underscored the challenges posed by the integration of renewable energy sources, which introduce additional volatility and unpredictability into the market [1, 22]. Furthermore, the black-box nature of many advanced machine learning models, such as deep neural networks, raises concerns about interpretability and trust among stakeholders [2].

Another significant gap lies in the scarcity of comprehensive frameworks that synergize the strengths of various forecasting approaches—statistical, machine learning, and novel methodologies like fractal and memory-based models—in a cohesive, interpretable manner [3, 4]. The literature also points to a lack of rigorous evaluation of these integrated models in real-world market conditions, highlighting an opportunity for impactful research contributions [5].

### **1.5.2 Thesis Objectives**

This thesis seeks to bridge these gaps through several targeted objectives:

- To critically evaluate the efficacy of fractal and memory-based models for forecasting electricity prices, with a focus on their ability to decipher complex market dynamics [6, 7].

- To develop and validate a hybrid forecasting framework that melds statistical, machine learning, and alternative approaches, emphasizing accuracy, interpretability, and real-world applicability [8, 9].
- To investigate the impacts of renewable energy integration and regulatory shifts on market prices, integrating these insights into the forecasting models for a more nuanced understanding of price determinants [10, 11].
- To enhance the transparency and interpretability of forecasting models, thereby fostering trust and enabling more informed decision-making among market participants [12].

### 1.5.3 Expected Contributions

This research is poised to make several significant contributions to the field. By advancing the theoretical framework around alternative modeling approaches and their integration into hybrid models, it aims to offer novel insights into electricity price forecasting. The development of a comprehensive, hybrid forecasting framework will not only set new standards for forecasting accuracy but also address the pressing need for models that stakeholders can interpret and trust.

Additionally, by systematically incorporating factors like renewable energy and regulatory changes into the forecasting process, this thesis will shed light on their complex effects on electricity prices. Such insights are invaluable for market participants navigating the intricacies of deregulated markets.

The emphasis on model interpretability and stakeholder usability marks a pivotal shift towards bridging the gap between advanced computational techniques and practical market applications. This approach aligns with recent calls in the literature for more user-friendly, transparent forecasting tools that can demystify complex market dynamics for a broader audience [13, 14].

#### 1.5.4 Scientific Contribution

The methodologies and insights derived from this thesis are expected to be a substantial addition to the scientific discourse on electricity price forecasting. By addressing the identified research gaps and pushing the boundaries of current forecasting methodologies, this work lays the groundwork for future investigations into more adaptive, reliable, and interpretable models. This contribution not only advances academic knowledge but also has the potential to revolutionize market participants' approach to navigating the volatile landscape of electricity markets.

#### 1.6 Thesis Structure

The remainder of this thesis is structured as follows:

- **Chapter 2: Literature Review** - This chapter provides an extensive review of the existing literature on electricity price forecasting, including traditional statistical models, early machine learning approaches, advanced deep learning techniques, and alternative methodologies. It also highlights the identified research gaps and sets the foundation for the methodologies used in this study.
- **Chapter 3: Methodology** - This chapter details the methodological framework employed in this research, including data collection and processing, model selection, and the implementation of forecasting models. It also describes the transfer learning approach used to enhance model performance across different datasets.
- **Chapter 4: Implementation** - This chapter provides a detailed explanation of how the forecasting models were implemented. It includes the technical steps, coding environments, and specific configurations used for each model.

- **Chapter 5: Data Analysis, Results, and Conclusion** - In this chapter, the results of the data analysis and the performance of the forecasting models are presented. It includes descriptive statistics, performance metrics, and the impact of geopolitical events on electricity prices. The effectiveness of transfer learning is also evaluated. The chapter concludes with a summary of the key findings, reiterating the contributions to the field of electricity price forecasting, and provides a concluding perspective on the study's impact and significance.
- **Chapter 6: Discussion and Future Work** - This chapter discusses the implications of the findings, addresses the limitations of the study, and suggests potential directions for future research. It emphasizes the need for continuous improvement in forecasting methodologies to adapt to the evolving dynamics of electricity markets.

## 2 Literature Review

Electricity Price Forecasting (EPF) has emerged as a pivotal function within deregulated electricity markets, facilitating the nuanced navigation required between supply, demand, and market pricing dynamics. The shift from regulated monopolies towards competitive market structures underscores the imperative for accurate forecasting techniques. These techniques are essential for informed decision-making, optimizing economic efficiency, and ensuring grid stability. The advocacy for competition to enhance market efficiency has necessitated the development of sophisticated financial instruments and advanced forecasting models to adeptly manage the complexities introduced by price volatility.

In deregulated electricity markets, price volatility is significantly influenced by the dynamic interplay of demand fluctuations, fuel price variability, and the intermittent nature of renewable energy sources. The inherent challenges associated with electricity—primarily its difficulty to store and the necessity for its production and consumption to occur simultaneously—exemplify the unique characteristics of electricity markets. These aspects contribute to the complex and volatile nature of electricity pricing, necessitating advanced and precise forecasting models [1, 2].

Historically, the foundation of EPF was laid by statistical models like Autoregressive Integrated Moving Average (ARIMA), which provided essential insights into linear relationships within time series data. These models were instrumental in the early stages of EPF, particularly within more predictable, regulated markets. However, the transition to deregulated markets revealed the limitations of these traditional models, as they struggled to capture the complex, non-linear dynamics prevalent in these environments [4, 5].

The evolution of forecasting methodologies saw the introduction of machine learning (ML) and deep learning (DL) techniques, representing a significant shift towards



models capable of addressing the non-linear characteristics of electricity prices. Models such as Artificial Neural Networks (ANNs), Support Vector Machines (SVM), and Long Short-Term Memory (LSTM) networks, which utilize historical data to uncover patterns, have marked a new era in forecasting. These advancements promise enhanced accuracy but also present challenges in model interpretability and the fine-tuning of hyperparameters [15, 16].

Recent advancements in EPF have focused on the integration of sophisticated computational techniques and the development of hybrid models. These efforts aim to combine the predictive strengths of diverse methodologies to more accurately address the volatility and unpredictability inherent in electricity markets. Such progress is critical for the advancement of forecasting tools that can meet the demands of increasingly complex and deregulated markets [21, 17].

EPF remains a critical component of deregulated electricity markets, with the accuracy and reliability of forecasts becoming increasingly vital. The progression from traditional statistical methods to contemporary ML and DL techniques reflects the ongoing efforts to adapt to the intricacies of electricity pricing dynamics. As the market continues its trajectory towards enhanced sustainability and efficiency, the refinement and development of forecasting models will be paramount in securing a stable and economically viable energy future.

The bedrock of electricity price forecasting (EPF) in the early days of deregulated markets was laid by traditional statistical methods. These methods, characterized by their simplicity and theoretical foundation, were initially perceived as adequate tools to predict electricity prices. However, as the complexity of the electricity market evolved, the limitations of these traditional forecasting methods became increasingly apparent.

## 2.1 Statistical Models

The Autoregressive Integrated Moving Average (ARIMA) model and its variants, such as Seasonal ARIMA (SARIMA), have been prominently used in EPF due to their capability to model a wide range of time series data under the assumption of linearity and stationarity [4]. These models describe the autocorrelations in data, making them suitable for short-term forecasting where price series exhibit regular patterns. However, the deregulation of electricity markets introduced complexities that often violate the assumptions underpinning ARIMA models. The non-stationary nature of electricity prices, characterized by sudden spikes or drops due to demand-supply imbalances, poses a significant challenge for these models.

## 2.2 Volatility Models

To capture the volatility clustering common in financial markets, including electricity markets, Generalized Autoregressive Conditional Heteroskedasticity (GARCH) models emerged as an extension of ARIMA. GARCH models are designed to model varying variances over time, indicative of periods of relative calm and turbulence in electricity prices [22]. Despite their improved handling of volatility, GARCH models still struggle with the extreme price jumps and the non-linear dynamics prevalent in deregulated electricity markets.

## 2.3 Challenges and Limitations

The primary challenge facing traditional forecasting methods lies in their inability to capture the non-linear and complex relationships within the electricity market. Factors such as regulatory changes, the integration of renewable energy sources, and unexpected outages introduce dynamics that these linear models cannot accurately

predict. Additionally, the assumption of stationarity and linearity, foundational to these models, is seldom met in the volatile environment of electricity markets [1].

The limitations of traditional forecasting methods, particularly their struggle with the non-stationarity and non-linearity of electricity price data, led to a burgeoning interest in alternative approaches. Researchers and practitioners began exploring machine learning techniques as potential solutions to the inadequacies of statistical models. This shift was motivated by the need for models that could adapt to the rapidly changing dynamics of electricity markets and handle the increasing volume and variety of data influencing price movements [2].

In summary, while traditional forecasting methods laid the foundational principles for EPF, their limitations in the face of deregulated market complexities necessitated the exploration of more sophisticated approaches. The advent of machine learning and deep learning models represented a paradigm shift towards methodologies capable of addressing the intricate and dynamic nature of electricity prices, setting the stage for the next generation of forecasting models.

## **2.4 Early Machine Learning Approaches**

The limitations inherent in traditional forecasting methods, particularly their inability to model the non-linear and volatile nature of electricity prices effectively, catalyzed the exploration of early machine learning (ML) approaches in EPF. These approaches marked a significant shift in forecasting methodologies, introducing more flexible and powerful tools capable of handling the complexities of deregulated electricity markets.

### **2.4.1 Introduction of Neural Networks**

Among the first ML methods applied to EPF were Artificial Neural Networks (ANNs). ANNs, inspired by the biological neural networks that constitute animal brains, are

systems of interconnected nodes or "neurons" that can process complex patterns in data. The ability of ANNs to learn from historical data and capture non-linear relationships made them particularly appealing for EPF, where price dynamics are influenced by a multitude of factors beyond simple supply and demand [21].

#### **2.4.2 Radial Basis Function Networks and Multilayer Perceptrons**

RBF networks and MLPs are specific types of ANNs that were explored for their potential in EPF. MLPs, with their layered structure and backpropagation learning algorithm, were utilized for their capacity to approximate virtually any non-linear function, making them suitable for predicting complex price patterns. RBF networks, known for their simplicity and the speed of learning, offered an alternative approach, particularly effective in scenarios where the relationship between input variables and the target variable (electricity price) is highly non-linear [15].

#### **2.4.3 Support Vector Machines (SVM)**

Another early ML approach adopted for EPF was the Support Vector Machine (SVM). SVMs are supervised learning models that analyze data used for classification and regression analysis. In the context of EPF, SVMs were valued for their ability to perform well in high-dimensional spaces and their effectiveness in regression tasks, making them a robust tool for forecasting prices in markets with high volatility and data variance [16].

#### **2.4.4 Challenges and Adaptations**

Despite the advantages offered by these early ML approaches, their application in EPF was not without challenges. The "black-box" nature of models like ANNs and SVMs raised concerns regarding interpretability and transparency, critical factors for

stakeholders in the electricity market. Moreover, the performance of these models heavily depended on the selection of hyperparameters and the architecture of the networks, requiring extensive experimentation and domain knowledge to optimize.

#### **2.4.5 Shift Towards Hybrid and Advanced ML Models**

The recognition of these challenges, combined with the evolving complexity of electricity markets, prompted further research into hybrid models that combine traditional statistical methods with ML techniques. The goal was to leverage the strengths of both approaches to improve forecasting accuracy while addressing the limitations of early ML models in handling extreme market events and non-linear dynamics [17].

The adoption of early ML approaches in EPF represented a pivotal development in the quest for more accurate and reliable forecasting models. These methodologies provided the foundation for subsequent innovations in the field, including the integration of deep learning and hybrid models, aimed at further enhancing the precision and adaptability of EPF tools in response to the challenges posed by deregulated electricity markets.

### **2.5 Advanced Approaches and Deep Learning**

The limitations of early machine learning approaches in handling the full complexity and non-linearity of electricity prices in deregulated markets spurred the interest in deeper, more sophisticated models. This interest coalesced around deep learning (DL) techniques and the development of hybrid models, combining various forecasting methodologies to enhance predictive accuracy and reliability.

### **2.5.1 Deep Learning in EPF**

Deep learning, a subset of machine learning inspired by the structure and function of the brain's neural networks, utilizes layered architectures known as neural networks with many layers. These models, particularly Recurrent Neural Networks (RNNs) and Long Short-Term Memory (LSTM) networks, have shown great promise in EPF due to their ability to process sequential data and capture temporal dependencies, a critical aspect given the time-series nature of electricity price data [20, 21]. LSTMs, with their specialized architecture for remembering information over long periods, have been particularly effective in forecasting electricity prices, addressing the challenges of volatility and the influence of external factors like weather conditions and renewable energy generation.

### **2.5.2 Hybrid Models**

Hybrid models in EPF represent an innovative approach that synthesizes the strengths of statistical methods, traditional machine learning, and deep learning techniques. By integrating these disparate models, researchers aim to capture both linear and non-linear relationships in the data, mitigate the limitations of individual models, and improve overall forecasting performance. Examples include combining wavelet transforms with ANN or LSTM models to preprocess and decompose the price time series into more manageable components before forecasting [15, 16]. This preprocessing step enhances the model's ability to detect and model the underlying patterns in the data, leading to more accurate and robust forecasts.

### **2.5.3 Challenges and Opportunities**

Despite their advanced capabilities, deep learning and hybrid models introduce new challenges, particularly regarding computational demands and the need for large

datasets for training. Moreover, the "black-box" nature of these models persists, presenting difficulties in interpreting the models' decision-making processes which is a significant concern for stakeholders requiring transparency in forecasting. Addressing these challenges has become a focal point of ongoing research, with efforts focused on improving model interpretability, reducing computational requirements, and optimizing models for better generalization across different market conditions.

#### **2.5.4 Future Directions**

The advent of deep learning and the exploration of hybrid models have set new benchmarks in the accuracy and reliability of EPF. Future research is likely to explore more sophisticated hybrid models that leverage the latest advancements in AI and ML, such as Generative Adversarial Networks (GANs) for generating synthetic electricity price data, and reinforcement learning for dynamic adaptation to market changes. Furthermore, the integration of external data sources, including weather forecasts and socio-economic indicators, into these models promises to enhance their predictive capabilities further, aligning EPF more closely with the realities of a rapidly evolving energy landscape.

The advancements in deep learning and the development of hybrid models represent a significant leap forward in EPF. These methodologies not only offer the potential for unprecedented forecasting accuracy but also embody the continuous evolution of the field towards more adaptive, robust, and transparent forecasting solutions, catering to the complex needs of deregulated electricity markets.

## **2.6 Alternative Approaches**

As the electricity market continues to evolve, the quest for more accurate and reliable forecasting methods has led researchers to explore beyond the confines of traditional

statistical, machine learning, and even advanced deep learning techniques. This exploration has unearthed alternative approaches that provide unique insights into the complex dynamics of electricity prices.

### **2.6.1 Fractal Approaches**

Fractal theory, which examines data patterns that repeat at different scales, introduces a fascinating angle to EPF. The foundational work by Mandelbrot on fractals has inspired applications in financial markets, suggesting that electricity prices might also exhibit fractal-like behavior. This perspective has driven the exploration of fractal geometry to model the electricity market's intricacies, focusing on identifying self-similar patterns within price data. While still an emerging area of research, fractal approaches hold promise for uncovering deep-seated structures in electricity prices, potentially offering more nuanced forecasts that traditional linear models often overlook [6].

### **2.6.2 Memory-Based Models**

Another promising direction is memory-based approaches, such as the k-Nearest Neighbors (k-NN) algorithm, which forecasts future prices based on the most similar historical patterns. This method hinges on the principle that past market behaviors can offer valuable insights into future price movements, especially when dealing with seasonal and recurring patterns in electricity demand and pricing. Memory-based models, by directly leveraging historical data without assuming a specific underlying model, offer flexibility and adaptability in capturing the cyclical nature of electricity markets [18].



### **2.6.3 Hybrid and Ensemble Techniques**

Building on the strengths of various forecasting methods, hybrid and ensemble techniques have emerged as powerful tools in EPF. These approaches combine multiple forecasting models, including traditional, machine learning, fractal, and memory-based methods, to achieve superior accuracy. By aggregating the forecasts from different models, hybrid and ensemble techniques can mitigate the weaknesses of individual models and capitalize on their strengths, leading to more reliable and robust predictions. This strategy is particularly effective in addressing the multifaceted challenges of EPF, where single-model approaches may fall short due to the market's complexity and volatility.

### **2.6.4 Challenges and Future Research Directions**

While alternative forecasting approaches offer new perspectives and potential improvements in EPF accuracy, they also present challenges. Fractal and memory-based models, for instance, require in-depth analysis to identify appropriate scales and parameters for modeling. Additionally, the integration of these alternative methods into hybrid and ensemble frameworks necessitates sophisticated algorithms for model selection and combination, ensuring that the aggregated forecast optimally balances the contributions of each method.

The continuous innovation in EPF methodologies highlights the field's dynamic nature and its critical role in supporting the efficient operation of deregulated electricity markets. Future research is likely to delve deeper into alternative forecasting approaches, refining and integrating these methods within comprehensive frameworks that can adeptly navigate the complexities of electricity price dynamics. Moreover, advancements in computational techniques and data analytics will further enhance the ability of these models to provide timely, accurate, and transparent forecasts, em-

powering stakeholders to make informed decisions in an increasingly complex energy landscape.

The advancement in EPF methodologies, from traditional statistical models to sophisticated deep learning and alternative approaches, underscores the field's dynamic evolution. However, the effectiveness of these models varies significantly across different markets and conditions, necessitating a critical evaluation to understand their strengths, weaknesses, and applicability.

## **2.7 Performance Across Markets**

The variance in model performance can be attributed to several market-specific factors, including the market structure, the level of competition, the mix of generation sources, and the presence of renewable energy sources. For instance, studies have shown that while deep learning models like LSTMs exhibit superior performance in markets with high data availability and variability, simpler models like SVMs or even traditional time-series models might perform adequately in less volatile markets [15, 21]. This variance highlights the importance of tailoring the forecasting approach to the specific characteristics and needs of each market.

## **2.8 Influence of Data Availability and Quality**

The accuracy of EPF models is heavily dependent on the availability and quality of input data. High-resolution data, encompassing a broad spectrum of market and external factors (e.g., demand, weather conditions, fuel prices), can significantly enhance model performance. However, challenges such as missing data, inaccuracies, and the time lag in data collection can impair the models' effectiveness, underscoring the need for robust data preprocessing and validation techniques [16].

## 2.9 Model Complexity vs. Interpretability

A recurring theme in the evaluation of EPF models is the trade-off between complexity and interpretability. While more complex models, such as deep neural networks, may offer higher accuracy, their "black-box" nature can pose challenges for interpretability and trust among stakeholders. Conversely, simpler models or those with inherent interpretability features (e.g., decision trees) may facilitate easier understanding and adoption, despite potentially lower accuracy [2]. This trade-off emphasizes the need for a balanced approach, considering both the accuracy requirements and the stakeholders' ability to interpret and act on the forecasts.

## 2.10 Adaptation to Market Dynamics

The rapidly changing dynamics of electricity markets, driven by factors such as regulatory changes, technological advancements, and the increasing integration of renewable energy, require forecasting models to be highly adaptable. Models that can dynamically update or retrain in response to changing market conditions are more likely to maintain high levels of accuracy over time. This adaptability is particularly crucial for managing the unpredictability introduced by renewable energy sources, which can significantly impact supply and demand balances [1].

## 2.11 Future Directions and Challenges

The ongoing evolution of EPF methodologies faces several challenges, including improving model accuracy in the face of market and data complexity, enhancing interpretability, and ensuring the models' adaptability to changing market conditions. Future research is likely to explore the integration of advanced machine learning techniques, such as reinforcement learning and transfer learning, to address these challenges. Additionally, the development of standardized evaluation frameworks

and benchmarks could facilitate more systematic comparison and improvement of forecasting models across different markets and conditions.

In conclusion, the critical evaluation of EPF models reveals a landscape marked by diverse methodologies, each with its own set of strengths and limitations. The quest for the optimal forecasting approach remains a dynamic and ongoing process, reflecting the complexity of electricity markets and the evolving needs of market participants. As the field progresses, the balance between accuracy, interpretability, and adaptability will continue to guide the development of more sophisticated and effective forecasting tools.

## **2.12 Research Gaps and Future Directions**

Despite significant advancements in EPF methodologies, several research gaps remain, highlighting opportunities for future studies to enhance forecasting accuracy, reliability, and usability. Addressing these gaps is crucial for developing forecasting models that can effectively support decision-making in increasingly complex and dynamic electricity markets.

### **2.12.1 Integration of Renewable Energy Sources**

One of the most pressing challenges in EPF is accurately accounting for the impact of renewable energy sources on electricity prices. The intermittent and unpredictable nature of renewables, such as wind and solar power, introduces substantial volatility into the market. Current forecasting models often struggle to fully capture this variability, underscoring the need for improved methodologies that can integrate weather forecasts, renewable production data, and market responses into the forecasting process [1].

### **2.12.2 Advanced Machine Learning Techniques**

While machine learning and deep learning have significantly improved EPF, there is still room for leveraging more advanced techniques. Areas such as reinforcement learning, transfer learning, and generative adversarial networks (GANs) present promising avenues for future research. These techniques can offer novel approaches to model training, adaptation, and the generation of synthetic data for enhanced model robustness [2].

### **2.12.3 Model Interpretability and Trust**

The "black-box" nature of many advanced forecasting models poses challenges for interpretability and trust among stakeholders. Developing models that not only provide accurate forecasts but are also interpretable and transparent is a crucial research direction. Techniques for model explanation, such as LIME (Local Interpretable Model-agnostic Explanations) and SHAP (SHapley Additive exPlanations), could be explored within the context of EPF to bridge the gap between model complexity and user trust [23].

### **2.12.4 Real-time Data Processing and Forecasting**

The ability to process real-time data and update forecasts accordingly is becoming increasingly important as electricity markets grow more dynamic. Research into models and systems that can efficiently handle streaming data, providing near-real-time forecasts, would be highly valuable. This includes exploring the potential of edge computing and real-time analytics for faster decision-making support.

### **2.12.5 Cross-Market Dynamics and Transfer Learning**

Electricity markets do not operate in isolation; they are influenced by interconnected market dynamics and regulatory environments. Investigating the cross-market influences on price formation and leveraging transfer learning to apply insights from one market to another could uncover new strategies for improving EPF accuracy. This approach could be particularly beneficial for emerging markets or those with limited historical data [21].

### **2.12.6 Standardization of Evaluation Frameworks**

A significant gap in EPF research is the lack of standardized evaluation frameworks and benchmarks. Establishing common benchmarks and performance metrics would facilitate more meaningful comparisons between different forecasting models and methodologies, accelerating the identification and adoption of best practices across the field.

### **2.12.7 Conclusion**

The exploration of research gaps and future directions in EPF underscores the field's vibrant and evolving nature. As electricity markets continue to transform, driven by technological advancements and the shift towards renewable energy, the demand for sophisticated, reliable, and interpretable forecasting models will only increase. Future research efforts, guided by these identified gaps, hold the potential to significantly advance EPF, supporting more efficient and sustainable electricity market operations.

## 3 Methodology

### 3.1 Overview

The methodology adopted in this study aims to rigorously assess the performance of various electricity price forecasting models and evaluate the impact of transfer learning within this context. The process begins with the systematic collection of electricity market data from the ENTSO-E Transparency Platform, covering Germany, Belgium, and the Netherlands for the period 2019-2021. This data undergoes meticulous cleaning and preprocessing to ensure its quality and suitability for analysis.

Following data preparation, a diverse set of forecasting models is selected for evaluation, including Autoregressive with Exogenous variables (ARX), k-nearest Neighbors (kNN), Random Forest Regression (RFR), Regression Trees, Support Vector Regression (SVR), Artificial Neural Network - Multi-Layer Perceptron (ANN-MLP), and Long Short-Term Memory (LSTM) networks. Each model is trained on the German dataset, leveraging its rich and complex data to develop robust predictive capabilities.

The models' performance is evaluated using a suite of statistical metrics, specifically Mean Absolute Error (MAE), Root Mean Square Error (RMSE), and Symmetric Mean Absolute Percentage Error (sMAPE), to provide a comprehensive assessment of accuracy and reliability. Based on this evaluation, the best-performing model is identified and subsequently retrained on the Belgian dataset to facilitate the transfer learning process.

Transfer learning techniques are employed to adapt the model trained on the Belgian dataset for forecasting electricity prices in the Netherlands. This involves fine-tuning the model parameters to accommodate the unique characteristics of the Dutch market while retaining the learned knowledge from the Belgian market. The effectiveness of this transfer learning approach is then compared against a model

trained solely on the Dutch dataset from scratch.

This methodological framework is designed to evaluate the forecasting accuracy of various models and explore the potential benefits of transfer learning in enhancing model performance across different market contexts. Detailed descriptions of each algorithm, the implementation steps, and the evaluation metrics are provided in the subsequent sections.

## **3.2 Data Collection**

The foundation of any robust electricity price forecasting model lies in the quality and comprehensiveness of the data used. This study employs data from the European Network of Transmission System Operators for Electricity (ENTSO-E) Transparency Platform, which provides an extensive range of electricity market data across Europe. The datasets specifically used in this research encompass historical electricity prices, demand figures, generation statistics, and transmission data for Germany, Belgium, and the Netherlands from 2019 to 2021.

The ENTSO-E Transparency Platform was chosen as the primary data source due to its comprehensive coverage and reliability. It offers real-time and historical data crucial for understanding market dynamics and is widely recognized for its standardization of data formats, which facilitates comparative analysis across different European countries. The data collection involved automated scripts developed in Python, which utilized APIs provided by ENTSO-E to fetch data efficiently. This approach ensured that the data was collected in a structured format, allowing for easier processing and analysis.



### 3.3 Data Processing and Preparation

Effective data processing and preparation are critical to ensuring the accuracy and reliability of electricity price forecasting models. This section details the steps taken to address issues such as missing data and discrepancies in data reporting frequencies across the different datasets collected from Germany, Belgium, and the Netherlands.

#### 3.3.1 Handling Missing Data

- **Germany:** The dataset for Germany, one of Europe’s largest electricity exchanges, displayed missing data exclusively on the days when the time has been adjusted due to daylight saving changes. These missing entries occurred because the dataset recorded electricity prices and values in quarter-hour increments, creating gaps during the hour shift. To resolve this, entries corresponding to the missing time slots were identified and removed from the dataset to maintain consistency and data integrity.
- **Belgium and Netherlands:** The datasets from Belgium and the Netherlands did not contain missing values due to the preprocessing already performed on the ENTSO-E platform, which included adjustments for time changes.

#### 3.3.2 Data Aggregation and Timeframe Standardization

- **Germany:** The original data was already aligned with the quarter-hour reporting period used throughout the dataset. Additionally, a 'cluster' column was introduced to classify data points into the respective quarter of the hour, aiding in more granular analyses and modeling.
- **Belgium:** Belgium’s data was reported on an hourly basis. To align with the analysis framework and facilitate comparative analysis, each entry was tagged

with a 'cluster' representing the corresponding hour of the day.

- **Netherlands:** Unlike Belgium, the Dutch dataset initially presented a mismatch in reporting frequencies; while values were reported every quarter-hour, prices were reported on an hourly basis. To harmonize the dataset, values from each of the four quarters within an hour were aggregated to produce a consolidated hourly value. This adjustment ensured that both the values and prices were synchronized on an hourly timeframe. The 'cluster' for the Netherlands dataset was similarly adjusted to denote the hour of the day.

Through these meticulous data processing and preparation steps, the datasets for Germany, Belgium, and the Netherlands were optimized for use in sophisticated forecasting models. This preparation not only addressed data quality issues but also standardized the datasets for consistent analysis and comparative evaluations across different market conditions.

### 3.4 Data Description

To ensure clarity and accuracy in the analysis, it is essential to understand the specific attributes of each data column collected from the ENTSO-E Transparency Platform. Below are detailed descriptions for key variables included in the datasets:

- **Day-ahead Price [EUR/MWh]:** Represents the prices for each market time unit in each bidding zone, expressed in EUR per MWh. Publishing deadline: No later than one hour after gate closure.
- **Day-ahead Total Load Forecast [MWh] & Actual Total Load [MWh]:** Represents the forecasted and actual total load per bidding zone for each market time unit. Total load equals the sum of power generated minus the balance

of exports and imports, minus power absorbed by storage, adjusted for losses. Calculation: Average real-time load values per bidding zone per market time unit. Details include net generation (or estimated if not known), imports, exports, and absorbed energy not including stored energy. Publishing deadline: No later than one hour after the end of the operating period (H+1).

- **Solar Forecast [MWh], Wind Offshore Forecast [MWh], & Wind Onshore Forecast [MWh]:** Forecasts of net generation from solar, offshore wind, and onshore wind power, provided per bidding zone for each market time unit. Updates: Current forecast: Regularly updated throughout intra-day trading. Day ahead forecast at 18:00: Published no later than 18:00 Brussels time, one day before actual delivery. It represents the most recent forecast at that time and is not updated post-18:00. Intraday forecast at 8:00: Published at 8:00 Brussels time on the day of delivery for intra-day trading. Represents the most recent forecast at that time and is not updated post-8:00. Applicability: Only for bidding zones in Member States with more than 1% annual feed-in from wind or solar power or for bidding zones with more than 5% feed-in from wind or solar power.
- **Solar Actual Aggregated [MWh], Wind Offshore Actual Aggregated [MWh], & Wind Onshore Actual Aggregated [MWh]:** Actual aggregated net generation output from solar, offshore wind, and onshore wind per market time unit and per production type. Publishing deadline: No later than one hour after the operational period.

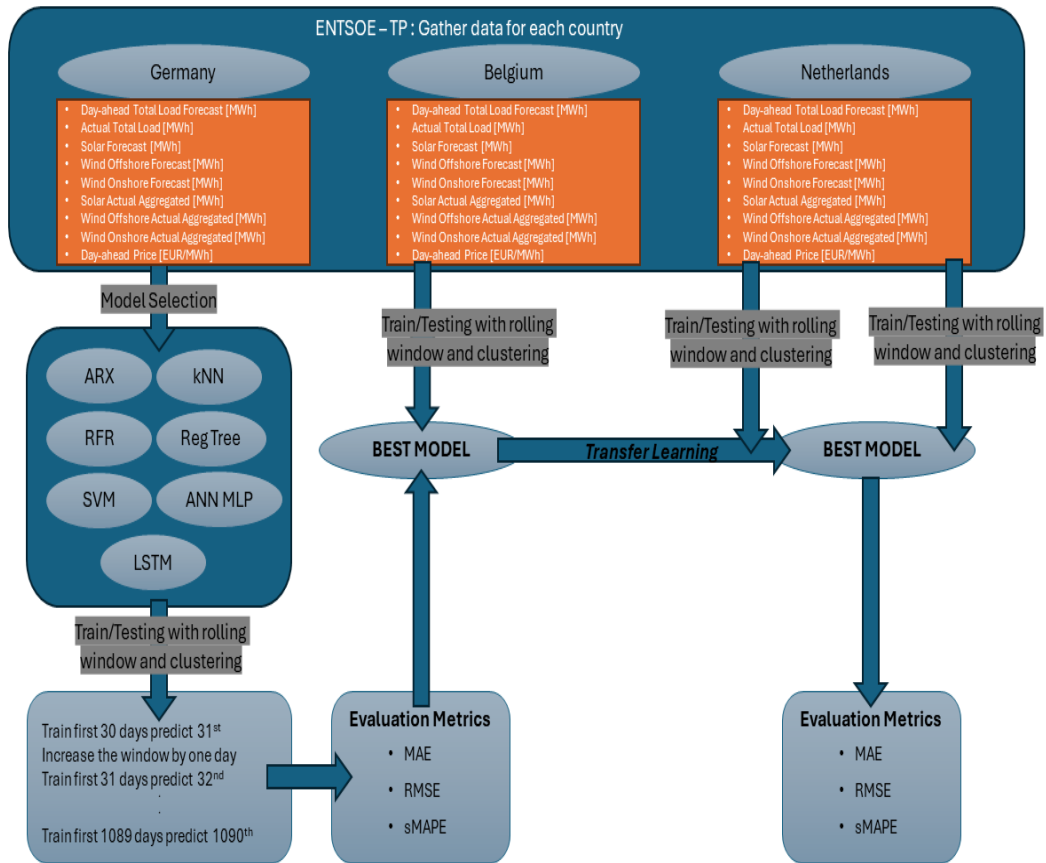

Figure 1: Overview of the Methodology

## 4 Implementation

### 4.1 Model Selection

Selecting appropriate models for electricity price forecasting (EPF) involves evaluating their strengths in handling the complexities of electricity market data. This study incorporates a diverse set of models, each chosen for its unique capabilities and suitability for specific aspects of EPF:

- **Autoregressive with Exogenous Variables (ARX):** Preferred for its ability to integrate past values of the target variable along with exogenous influences, making it ideal for scenarios where relationships are linear or nearly linear.
- **k-Nearest Neighbors (kNN):** Chosen for its non-parametric nature, which is effective in modeling nonlinear relationships without the need for complex configurations. kNN works by averaging the outputs of the nearest dataset points, thus adapting flexibly to changes in data.
- **Random Forest Regression (RFR):** Selected for its robustness and accuracy, Random Forest builds multiple decision trees and merges their outputs to prevent overfitting and to handle complex interactions between features effectively.
- **Regression Tree:** Utilized for its interpretability and ease of understanding, regression trees split data into branches, thereby simplifying the nonlinear forecasting into a series of decisions that can be easily analyzed.
- **Support Vector Regression (SVR):** Incorporated for its proficiency in managing high-dimensional spaces and its effectiveness in ensuring generalization by avoiding overfitting through the use of regularization techniques.

- **Artificial Neural Network - Multi-Layer Perceptron (ANN-MLP):** Employed for its deep learning capabilities, allowing it to learn intricate patterns in large volumes of data through multiple layers of processing.
- **Long Short-Term Memory (LSTM) networks:** Chosen for their ability to remember information for long periods, LSTMs are particularly effective in capturing temporal dependencies in time series data, crucial for forecasting in volatile markets like electricity pricing.

These models were selected based on their theoretical and practical capabilities to address the challenges inherent in forecasting electricity prices, which include non-linear relationships, complex interactions among variables, and the need for incorporating exogenous information like weather conditions and market policies.

## 4.2 Model Implementation

### 4.2.1 ARX (Autoregressive Model with Exogenous Variables)

The Autoregressive model with Exogenous variables (ARX) is a staple in econometrics and statistical forecasting, extending the classical autoregressive (AR) model by incorporating exogenous inputs. This model structure is particularly well-suited to time series data where external factors significantly influence the variable being forecast.

Mathematical Formulation:

$$y_t = \alpha + \sum_{i=1}^p \beta_i y_{t-i} + \sum_{j=1}^q \gamma_j X_{t-j} + \epsilon_t$$

Where:

- $y_t$  is the dependent time series at time  $t$ ,

- $\beta_i$  are the parameters for the lagged values of the dependent series,
- $X_{t-j}$  are the exogenous variables (external inputs) at time  $t - j$ ,
- $\gamma_j$  are the coefficients for the exogenous variables,
- $\epsilon_t$  is the error term, assumed to be white noise,
- $p, q$  represent the order of the autoregressive model and the number of lagged exogenous inputs, respectively.

The model accounts for the own past values of a series (autoregressive part) and the impact of external series (exogenous part), making it robust for scenarios where external influences such as economic, weather, or policy changes affect the forecast variable. The inclusion of exogenous variables allows the ARX model to adapt to shifts in the underlying process generating the data, which pure AR models might miss.

Model Training Details:

- **Data Preparation:** Before training, the data is partitioned into training and testing sets based on window sizes, exploring how the length of historical data influences predictive accuracy.
- **Parameter Optimization:** For the ARX model, the key parameters such as the number of lags ( $p$  and  $q$ ) are determined based on preliminary analyses such as the Partial Autocorrelation Function (PACF) for the dependent variable and the Cross-Correlation Function (CCF) for exogenous variables.
- **Model Fitting:** The model is fitted using linear regression techniques, where the dependent variable is regressed against its own lagged values and those of the exogenous inputs.

### 4.2.2 k-Nearest Neighbors (kNN)

The k-Nearest Neighbors (kNN) algorithm is a simple, versatile machine learning algorithm used for both classification and regression. It operates on the principle that similar instances tend to be near each other in feature space. The output for a regression task is computed as the average of the values of its k nearest neighbors.

Mathematical Formulation:

$$y = \frac{1}{k} \sum_{i \in N_k(x)} y_i$$

Where:

- $y$  is the predicted value,
- $k$  is the number of nearest neighbors,
- $N_k(x)$  denotes the set of  $k$  nearest neighbors to point  $x$ ,
- $y_i$  are the values of the  $k$  nearest neighbors.

Model Training Details:

- **Feature Scaling:** All features are standardized using MinMax scaling, bringing them within a  $[0, 1]$  range.
- **Parameter Tuning:** The number of neighbors,  $k$ , is a crucial parameter. A grid search over a range of possible  $k$  values (specifically from 3 to 100, stepping by 2) was conducted to identify the optimal  $k$ . Cross-validation within this search helped ensure that the chosen  $k$  generalizes well across different subsets of the data.



- **Optimal  $k$  Value:** The grid search determined that the optimal  $k$  for this specific dataset and problem is 31. This value provided the best balance between bias and variance, minimizing the prediction error on the validation set.
- **Distance Metric:** The Euclidean distance is used due to its effectiveness in many scenarios, though other metrics were considered during the exploratory phase.
- **Model Fitting and Evaluation:** The model is straightforwardly applied by storing the training data and using it for future predictions. Each test instance is compared against all stored instances to find the  $k$  closest neighbors, and predictions are made by averaging these neighbors' values.

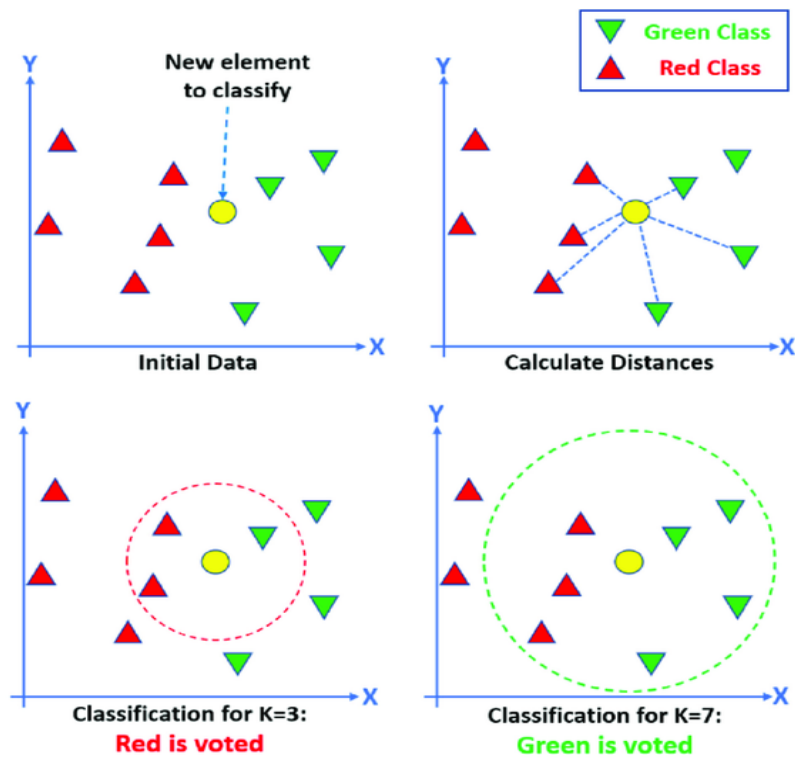

Figure 2:  $k$  Nearest Neighbours Descriptive [24]

### 4.2.3 Regression Tree

Regression Trees are decision trees designed for continuous outcome variables. They are advantageous for their interpretability and capability to model non-linear relationships by partitioning the feature space into simpler regions where responses are relatively homogenous.

Mathematical Formulation:

$$Y = f(X) = \sum_{m=1}^M c_m I(X \in R_m)$$

Where:

- $Y$  is the dependent variable,
- $X$  are the predictors,
- $R_m$  are the partitions of the input space,
- $c_m$  represents the mean response for the data points in  $R_m$ ,
- $I$  is an indicator function,
- $M$  is the total number of partitions.

Model Training Details:

- **Data Preparation:** Regression trees do not require feature scaling, as they are invariant to the magnitude of input features.
- **Tree Construction:**
  - **Splitting Criteria:** The model uses recursive binary splitting. At each node, the algorithm selects the split that results in the greatest reduction in MSE.

- **Pruning:** To avoid overfitting, the tree undergoes pruning, which involves removing splits that have little impact on the model’s predictive power, governed by a complexity parameter.
- **Parameter Tuning:** A grid search is performed to identify the optimal maximum depth of the tree. The depth should be sufficient to capture the complexity of the data but avoid overfitting.
- **Optimal Parameters:** For non-clustered data, the optimal tree depth was found to be 5. For clustered data, a slightly greater depth of 7 provided the best balance between model complexity and accuracy.

#### 4.2.4 Random Forest Regression

Random Forest Regression is an ensemble learning method that builds multiple decision trees during training and outputs the mean prediction of the individual trees. It improves upon the variance of single decision trees by averaging multiple predictions, which generally leads to better performance and robustness against overfitting.

Mathematical Formulation:

$$Y = \frac{1}{B} \sum_{b=1}^B f_b(X)$$

Where:

- $Y$  is the predicted outcome,
- $B$  is the number of trees in the forest,
- $f_b(X)$  is the prediction from the  $b$ -th decision tree,
- $X$  are the input features.

Model Training Details:

- **Feature Scaling:** Ensuring that all features are on the same scale can help in achieving faster convergence and a more balanced feature split.
- **Parameter Optimization:**
  - **Number of Estimators ( $n\_estimators$ ):** A grid search was conducted between 50 and 150 trees to find the optimal number.
  - **Maximum Depth ( $max\_depth$ ):** The grid search tested depths from 3 to 20 to avoid overfitting while ensuring sufficient model complexity.

- **Optimal Parameters:** The optimal configuration found was 100 trees ( $n\_estimators$ ) and a maximum depth of 5 ( $max\_depth$ ).
- **Cross-Validation:** To ensure that the model is not overfitting and performs well on unseen data, cross-validation was used during the grid search, specifically with a 5-fold strategy.

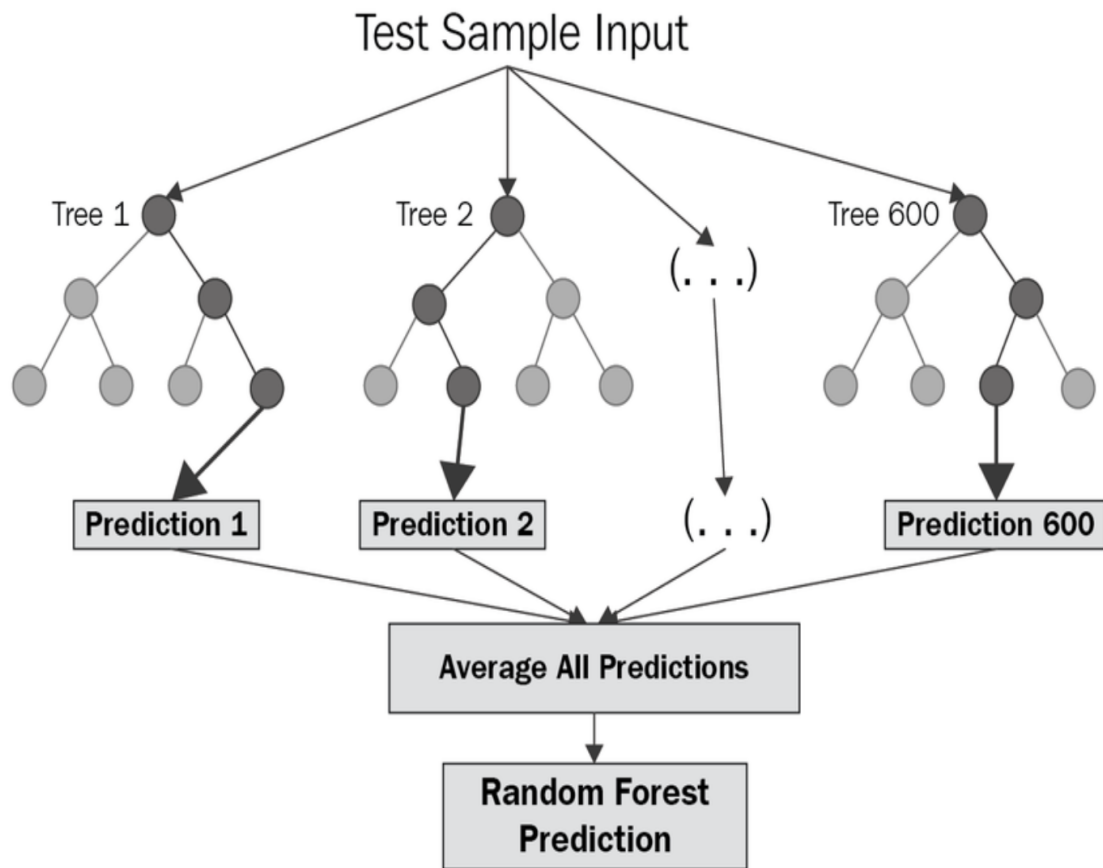

Figure 3: Random Forest Regressor Descriptive [28]

### 4.2.5 Support Vector Regression (SVR)

Support Vector Regression (SVR) extends the concepts of Support Vector Machines (SVM) to regression problems. It involves fitting a model within a certain threshold of the training data points while trying to minimize model complexity and error.

Mathematical Formulation:

$$f(x) = \langle w, x \rangle + b$$

Where:

- $w$  is the weight vector,
- $x$  is the feature vector,
- $b$  is the bias term.

Model Training Details:

- **Data Normalization:** Features were normalized using StandardScaler, ensuring mean subtraction and variance scaling to unit norms.
- **Hyperparameter Tuning:**
  - **Kernel:** The Radial Basis Function (RBF) kernel was chosen to handle non-linear relationships effectively.
  - **C (Regularization parameter):** Values tested ranged from 0.01 to 0.04.
  - **Epsilon:** Values like 0.085, 0.009, and 0.0095 were tested to fine-tune model sensitivity.
  - **Gamma:** The tested range was 0.01 to 0.04.

- **Optimal Parameters:** The best parameters found through GridSearchCV were:
  - For non-clustered data:  $C = 0.04$ ,  $\epsilon = 0.0085$ ,  $\gamma = 0.04$
  - For clustered data:  $C = 0.04$ ,  $\epsilon = 0.0085$ ,  $\gamma = 0.04$
- **Implementation:** Utilized a sliding window approach to predict future values, simulating a more realistic scenario where the latest data is utilized for forecasting.

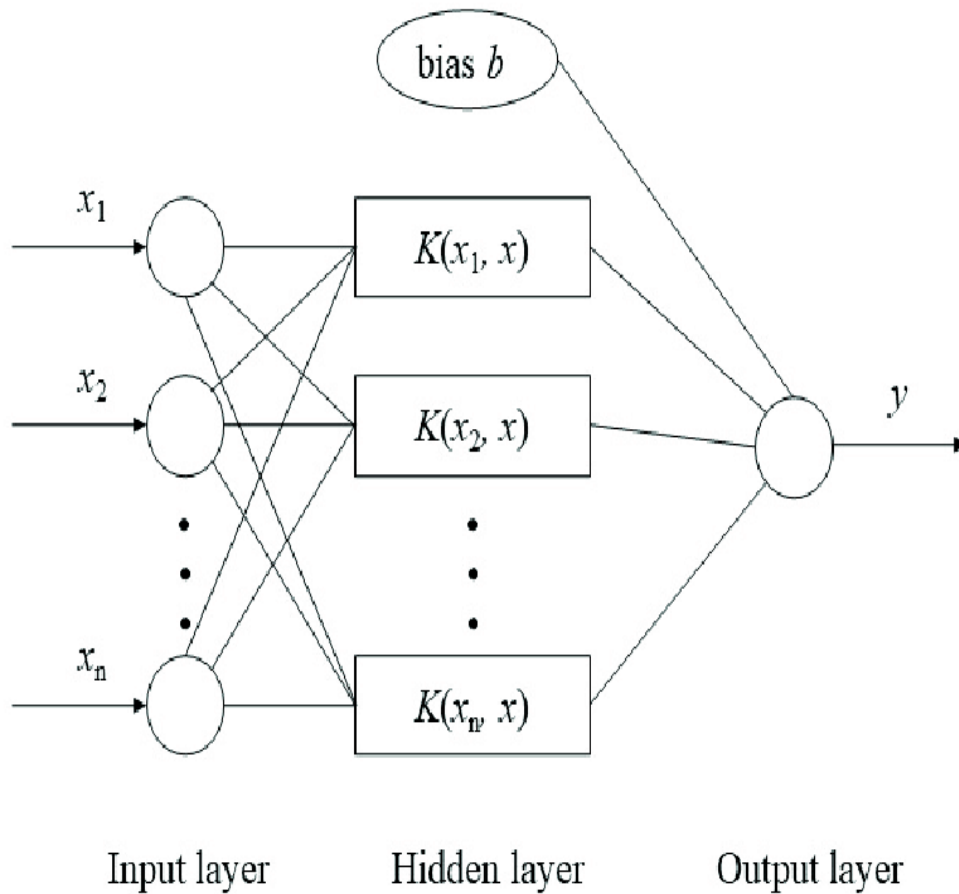

Figure 4: Support Vector Regressor Descriptive [29]

#### 4.2.6 Artificial Neural Network (ANN) for Electricity Price Forecasting

Artificial Neural Networks (ANNs) are inspired by the biological neural networks that constitute animal brains. An ANN is based on a collection of connected units or nodes called artificial neurons. Each connection can transmit a signal from one neuron to another. The receiving neuron processes the signal and signals downstream neurons connected to it.

Mathematical Formulation:

- **Linear Combination:**  $z = w_1x_1 + w_2x_2 + \dots + w_nx_n + b$
- **Activation Function:** Common activation functions include:
  - ReLU (Rectified Linear Unit):  $\sigma(z) = \max(0, z)$
  - Sigmoid:  $\sigma(z) = \frac{1}{1+e^{-z}}$
  - Tanh:  $\sigma(z) = \tanh(z)$
- **Output Calculation:** For an MLP with one hidden layer, the output  $y$  can be calculated as:  $y = \sigma(W^{(2)}(\sigma(W^{(1)}x + b^{(1)})) + b^{(2)})$
- **Error and Loss Function:** For regression tasks, Mean Squared Error (MSE) is often used:

$$\text{MSE} = \frac{1}{n} \sum_{i=1}^n (y_i - \hat{y}_i)^2$$

Model Training Details:

- **Data Normalization:** Inputs were standardized using StandardScaler.
- **Hyperparameter Tuning:**
  - **Architecture:** Tested configurations included two hidden layers with 64 and 32 neurons, respectively.



- **Activation Function:** ReLU
  - **Optimizer:** Adam
  - **Learning Rate Initiation:** Evaluated values were 0.001, 0.01, and 0.1.
  - **Maximum Iterations:** Set between 200 to 400 to define training epochs.
- **Optimal Parameters:**
    - Hidden Layers: (64, 32)
    - Activation: ReLU
    - Solver: Adam
    - Learning Rate: 0.01
    - Max Iterations: 200
- **Implementation:** A rolling window approach was implemented for training the ANN. This method involves sequentially moving the window of training data forward, incorporating more recent data into the training set while phasing out older data.

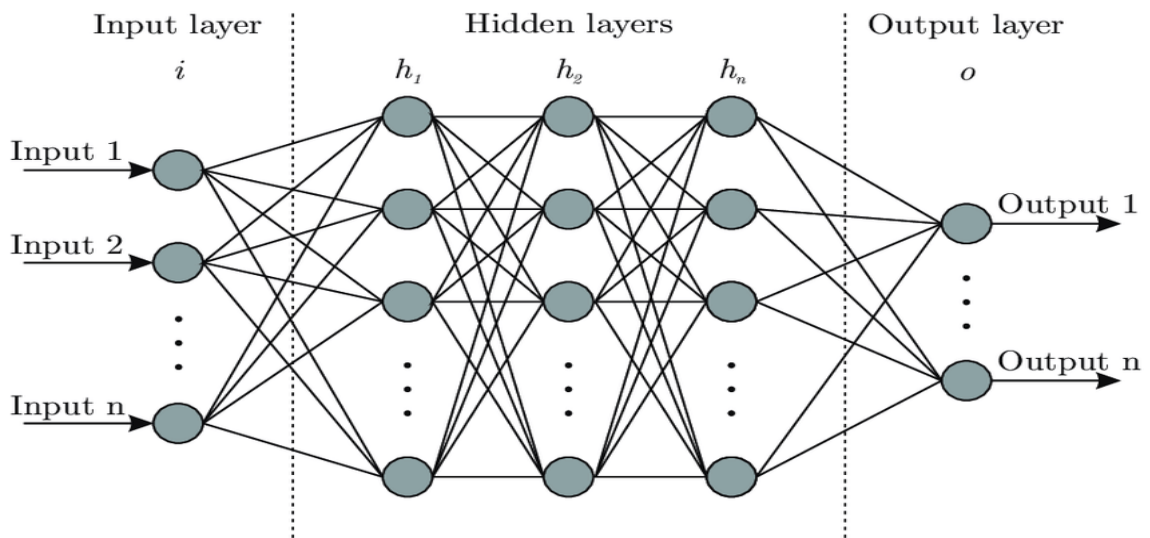

Figure 5: Artificial Neural Networks Descriptive [25]

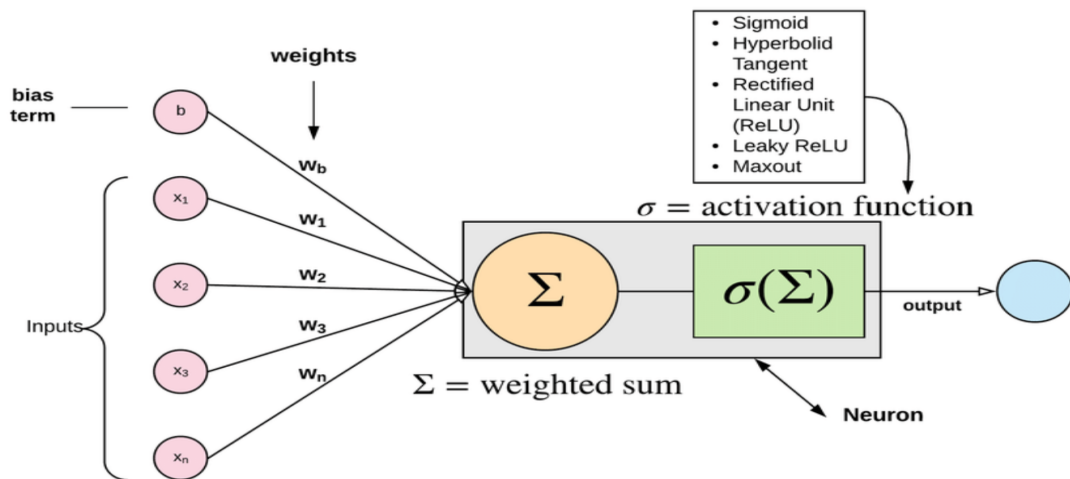

Figure 6: MLP Descriptive [27]

### 4.2.7 Long Short-Term Memory Network (LSTM)

LSTMs are specifically designed to avoid the long-term dependency problem, making them exceptionally good at capturing relationships in sequential data that unfold over prolonged periods.

Mathematical Formulation:

- **Forget Gate:**

$$f_t = \sigma(W_f[h_{t-1}, x_t] + b_f)$$

- **Input Gate and Candidate Layer:**

$$i_t = \sigma(W_i[h_{t-1}, x_t] + b_i)$$

$$\tilde{C}_t = \tanh(W_C[h_{t-1}, x_t] + b_C)$$

- **Output Gate:**

$$o_t = \sigma(W_o[h_{t-1}, x_t] + b_o)$$

$$h_t = o_t \tanh(C_t)$$

- **Cell State Update:**

$$C_t = f_t * C_{t-1} + i_t * \tilde{C}_t$$

Model Training Details:

- **Data Normalization:** Data is scaled using MinMaxScaler.
- **Sequence Creation:** Sequences of past data points are created as input for the LSTM.

- **Network Architecture:** Configured with layers of LSTM units. The optimal configuration includes:
  - Units: 50 per layer
  - Activation: ReLU
  - Optimizer: Adam
- **Training Process:** The model is trained using a rolling window approach.
- **Hyperparameters:** Optimal settings include a learning rate of 0.01 and 50 epochs.

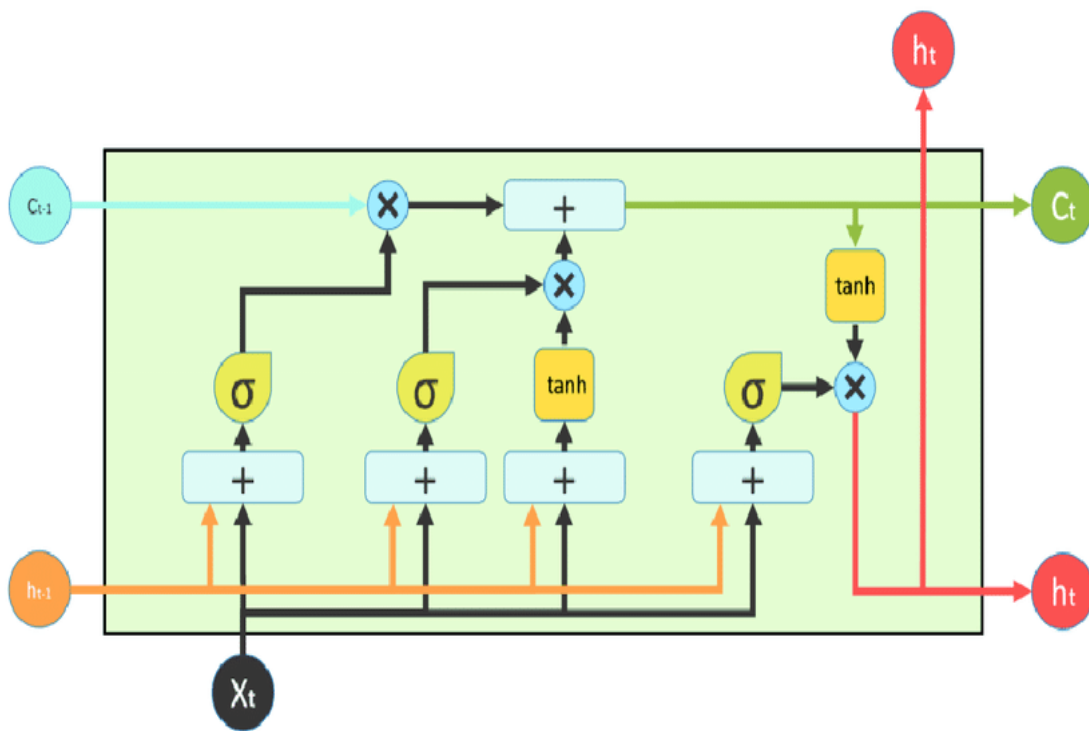

Figure 7: Long Short Term Memory Descriptive [26]

### 4.2.8 Transfer Learning

Transfer Learning is a machine learning technique where a model developed for one task is reused as the starting point for a model on a second task.

Mathematical Formulation:

- **Model Decomposition:** Assume a pre-trained model is decomposed into two parts:
  - **Base Model (f):** Consists of the initial layers that capture universal features.
  - **Task-Specific Model (g):** Includes the final layers specific to the original task.
- **Weight Transfer and Modification:**
  - **Freezing Layers:** The weights ( $W_f$ ) of the base model are kept frozen.
  - **Layer Re-training:** The task-specific layers ( $W_g$ ) are re-initialized or fine-tuned with new data.

$$W_g^* = \arg \min_{W_g} L(y, g(f(x; W_f); W_g))$$

Model Training Details:

- **Initialization:** The model weights are initialized using a pre-trained model.
- **Feature Adaptation:** Some layers may be retrained while others might be frozen.
- **Hyperparameter Tuning:** Parameters such as learning rate, number of re-trained layers, and epochs are tuned.

- **Outcome:** The model adapts to the new data, improving learning efficiency and prediction accuracy.

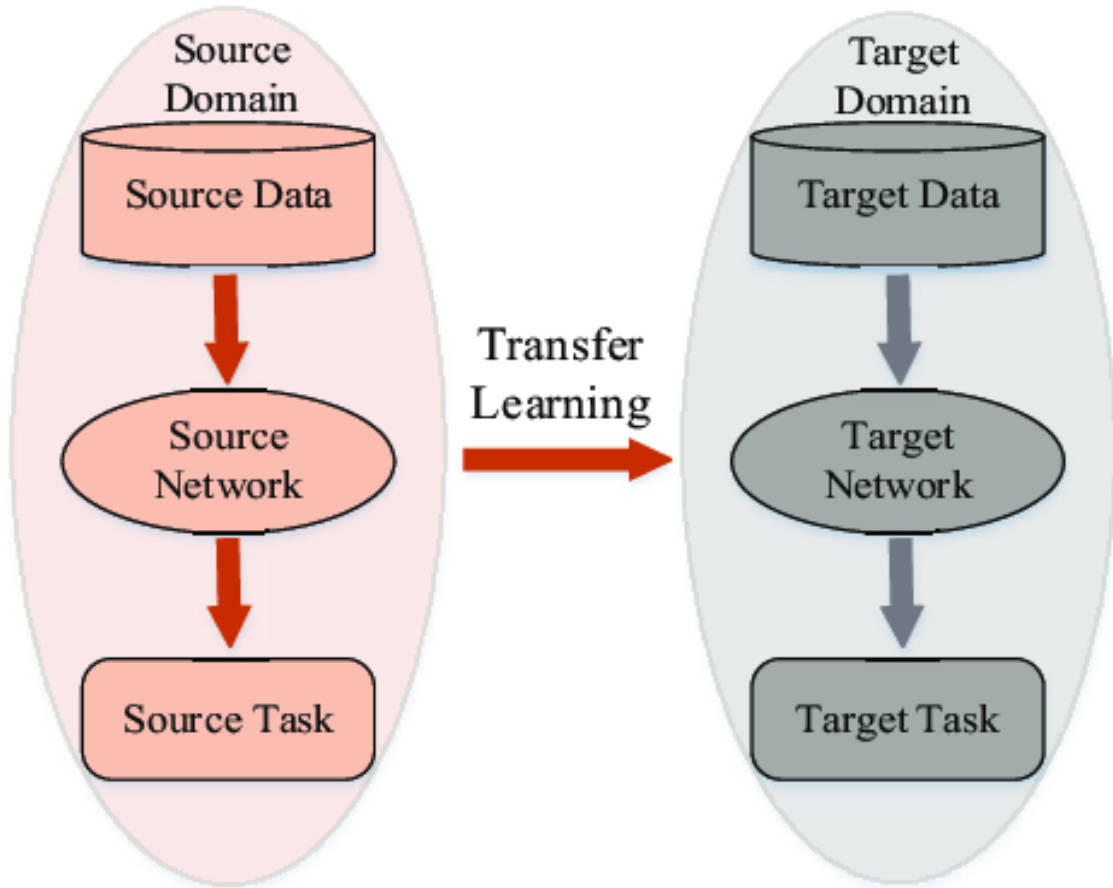

Figure 8: Transfer Learning Descriptive [30]

### 4.3 Evaluation Metrics

- **Mean Absolute Error (MAE):**

$$\text{MAE} = \frac{1}{n} \sum_{i=1}^n |y_i - \hat{y}_i|$$

- **Root Mean Squared Error (RMSE):**

$$\text{RMSE} = \sqrt{\frac{1}{n} \sum_{i=1}^n (y_i - \hat{y}_i)^2}$$

- **Symmetric Mean Absolute Percentage Error (sMAPE):**

$$\text{sMAPE} = \frac{100\%}{n} \sum_{i=1}^n \frac{|y_i - \hat{y}_i|}{(y_i + \hat{y}_i)/2}$$

These metrics serve to quantify the difference between predicted values and actual values, allowing analysts to assess the accuracy of forecasting models in a quantifiable manner. Each metric has its strengths and is chosen based on the specific requirements and sensitivity of the prediction task.

## 5 Data Analysis, Results, Conclusion

In this section, we delve into the analytical processes applied to the gathered data to extract meaningful insights and patterns that can inform our forecasting models. The analysis covers a basic descriptive statistics and representative cluster diagrams which aim at understanding the dynamics of electricity prices and demand across different time frames and market conditions. This comprehensive analysis not only aids in validating the data but also ensures the robustness and reliability of the forecasting models deployed in subsequent sections.

### 5.1 Descriptive Statistics

The Descriptive Statistics subsection provides a foundational understanding of the data characteristics for each country involved in the study—Germany, Belgium, and the Netherlands. By presenting key statistical measures such as mean, standard deviation, minimum, and maximum values, this analysis offers a snapshot of the central tendencies and variability within the datasets. These statistics are crucial for identifying outliers, understanding data distribution, and setting the stage for more detailed exploratory data analysis. Tables summarizing these statistics will facilitate a direct comparison across the datasets, highlighting unique features and potential anomalies in market behavior.



Germany (entries: 104828)

	Day-ahead Total Load Forecast* [GWh]	Actual Total Load* [GWh]	Solar Forecast* [GWh]	Wind Off-shore Forecast* [GWh]	Wind On-shore Forecast* [GWh]	Solar Actual* [GWh]	Wind Off-shore Actual* [GWh]	Wind On-shore Actual* [GWh]	Day-ahead Price [EUR / MWh]
<b>mean</b>	55.40	57.13	5.10	2.88	11.02	5.13	2.86	11.14	55.55
<b>std</b>	9.38	9.93	7.80	1.88	8.66	7.87	1.93	8.86	57.06
<b>min</b>	32.65	29.88	0.00	0.03	0.15	0.00	0.00	0.09	-
									149.99
<b>25%</b>	47.70	49.03	0.00	1.12	4.42	0.00	1.06	4.32	28.82
<b>50%</b>	55.33	56.88	0.15	2.71	8.49	0.10	2.70	8.51	41.59
<b>75%</b>	63.30	65.32	8.23	4.56	15.23	8.30	4.58	15.73	60.89
<b>max</b>	78.31	82.17	36.62	6.78	42.18	36.53	7.20	41.96	2985.76

Table 1: Germany: Descriptive Statistics (Values in columns marked with \* are in  $10^3$  GWh)

The statistics reveal that the mean day-ahead total load forecast is approximately 55.40 GWh, with a standard deviation of 9.38 GWh, indicating moderate variability. The actual total load has a slightly higher mean of 57.13 GWh and a similar standard deviation. The mean solar and wind forecasts and actuals show the expected variations, with significant maximum values indicating periods of high renewable energy production. The day-ahead price mean is 55.55 EUR/MWh, with substantial variability as indicated by the standard deviation of 57.06 EUR/MWh.

Belgium (entries: 26304)

	Day-ahead Total Load Forecast* [GWh]	Actual Total Load* [GWh]	Solar Forecast* [GWh]	Wind Off-shore Forecast* [GWh]	Wind On-shore Forecast* [GWh]	Solar Actual* [GWh]	Wind Off-shore Actual* [GWh]	Wind On-shore Actual* [GWh]	Day-ahead Price [EUR / MWh]
<b>mean</b>	38.20	38.10	0.47	0.81	0.45	0.47	0.70	0.43	58.43
<b>std</b>	5.29	5.28	0.74	0.67	0.40	0.76	0.65	0.41	57.91
<b>min</b>	26.33	24.98	0.00	0.00	0.00	0.00	0.00	0.00	-
<b>25%</b>	34.07	33.95	0.00	0.20	0.14	0.00	0.11	0.12	500.00
<b>50%</b>	38.01	38.04	0.01	0.67	0.32	0.01	0.48	0.30	30.40
<b>75%</b>	42.05	41.82	0.72	1.40	0.64	0.71	1.20	0.63	42.26
<b>max</b>	52.98	54.47	3.79	2.17	1.98	3.79	2.18	1.98	61.17
									620.00

Table 2: Belgium: Descriptive Statistics (Values in columns marked with \* are in  $10^3$  GWh)

The mean day-ahead total load forecast is 38.20 GWh, closely matching the actual total load mean of 38.10 GWh, suggesting accurate load forecasting. The solar and wind energy statistics reflect lower production levels compared to Germany, with mean values for wind offshore and onshore forecasts at 0.81 GWh and 0.45 GWh, respectively. The day-ahead price mean is 58.43 EUR/MWh, with a high standard deviation of 57.91 EUR/MWh, indicating price volatility.

Netherlands (entries: 26304)

	Day-ahead Total Load Forecast* [GWh]	Actual Total Load* [GWh]	Solar Forecast* [GWh]	Wind Off-shore Forecast* [GWh]	Wind On-shore Forecast* [GWh]	Solar Actual* [GWh]	Wind Off-shore Actual* [GWh]	Wind On-shore Actual* [GWh]	Day-ahead Price [EUR / MWh]
<b>mean</b>	47.41	49.94	2.60	1.77	3.60	0.10	2.43	2.02	58.78
<b>std</b>	8.67	7.71	4.26	1.24	3.23	0.20	2.17	1.71	54.48
<b>min</b>	17.70	26.18	0.00	0.01	0.03	0.00	0.00	0.00	-79.19
<b>25%</b>	41.52	43.86	0.00	0.61	1.03	0.00	0.71	0.65	32.10
<b>50%</b>	46.94	48.78	0.18	1.61	2.61	0.00	1.94	1.45	42.38
<b>75%</b>	52.57	55.23	3.64	2.92	5.35	0.11	3.21	3.01	60.26
<b>max</b>	77.45	72.08	23.85	5.83	23.38	1.33	9.01	8.53	620.00

Table 3: Netherlands: Descriptive Statistics (Values in columns marked with \* are in  $10^3$  GWh)

The mean day-ahead total load forecast stands at 47.41 GWh, while the actual total load mean is higher at 49.94 GWh. Solar energy statistics show lower production with a mean forecast of 2.60 GWh. Wind energy, both offshore and onshore, shows moderate production levels, with forecasts closely matching actual values. The day-ahead price mean is 58.78 EUR/MWh, with a standard deviation of 54.48 EUR/MWh, reflecting price fluctuations.

These descriptive statistics provide valuable insights into the central tendencies and variability of energy parameters, essential for refining forecasting models and managing energy markets effectively.

## 5.2 Comparative Descriptive Diagrams

In this section, we provide a comparative visual analysis of various energy parameters. The following diagrams illustrate the quarterly and hourly averages for each parameter, comparing the energy markets in these countries.

### 5.2.1 Day-ahead Total Load Forecast and Actual Total Load

#### Germany

- The day-ahead total load forecast and actual total load show a consistent trend, with the actual total load slightly higher on average. This indicates a generally accurate forecasting model with minor discrepancies.
- Variations in the forecast and actual loads are visible, highlighting periods of underestimation and overestimation.

#### Belgium

- Both day-ahead total load forecast and actual total load follow a similar pattern to Germany's, with the actual load often exceeding the forecast. This trend suggests similar forecasting accuracy and reliability.
- The hourly variations provide insight into peak demand periods and the effectiveness of the forecasting.

#### Netherlands

- The day-ahead total load forecast and actual total load for the Netherlands show a close alignment, similar to Belgium and Germany. However, the forecast tends to slightly underpredict the actual load.
- The hourly data reflects consistent forecasting performance with some deviations during peak hours.

## 5.2.2 Wind Onshore and Offshore Forecast and Actual Aggregated

### Germany

- The wind onshore forecast and actual aggregated values are closely matched, indicating a high degree of accuracy in wind energy forecasting.
- Offshore wind data shows a slight underestimation in forecasts compared to actual aggregated values, suggesting room for improvement in offshore wind predictions.

### Belgium

- Wind onshore forecast and actual aggregated data reveal a moderate level of accuracy, with some periods showing significant deviations.
- Offshore wind forecasts show more variability compared to actual aggregated values, highlighting the challenges in predicting offshore wind energy generation.

### Netherlands

- The wind onshore forecast and actual aggregated values are relatively aligned, similar to Germany and Belgium. This suggests a robust forecasting model for onshore wind.
- Offshore wind forecasts exhibit greater variance compared to actual values, indicating the need for enhanced forecasting techniques for offshore wind energy.

### 5.2.3 Solar Forecast and Actual Aggregated

#### Germany

- Solar forecast and actual aggregated values display a clear pattern of under-prediction, particularly during peak solar production periods. This suggests potential improvements in solar energy forecasting.
- The quarterly data shows significant seasonal variations, reflecting the impact of changing weather conditions on solar energy generation.

#### Belgium

- Solar forecasts tend to underpredict actual aggregated values, especially during high solar output periods. This trend is consistent with the patterns observed in Germany.
- Hourly data reveals fluctuations in solar production, highlighting the importance of accurate real-time forecasting.

#### Netherlands

- Similar to Germany and Belgium, the Netherlands' solar forecast generally underpredicts actual aggregated values, indicating a consistent pattern across these regions.
- The hourly variations emphasize the need for adaptive forecasting models that can account for rapid changes in solar energy output.

## 5.2.4 Day-ahead Price

### Germany

- The day-ahead price exhibits significant fluctuations, reflecting the dynamic nature of the energy market. Peak prices correspond with periods of high demand and lower renewable energy production.
- The quarterly averages show seasonal price trends, with higher prices during winter months due to increased heating demand.

### Belgium

- Similar to Germany, Belgium's day-ahead price shows variability, driven by market demand and supply conditions.
- The hourly data provides a detailed view of price changes throughout the day, highlighting the impact of renewable energy integration on market prices.

### Netherlands

- The day-ahead price in the Netherlands follows a similar pattern to Germany and Belgium, with price spikes during peak demand periods.
- Hourly variations offer insights into the market's response to fluctuations in renewable energy production and consumption patterns.

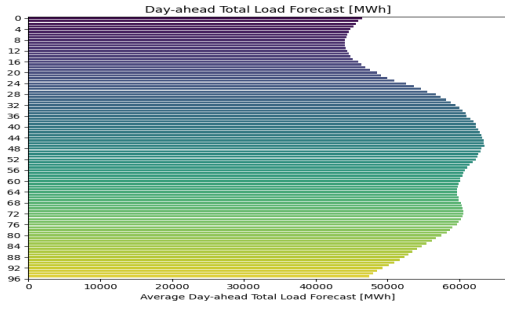

Figure 9: Germany: quarterly average Day-ahead total Load Forecast [MWh]

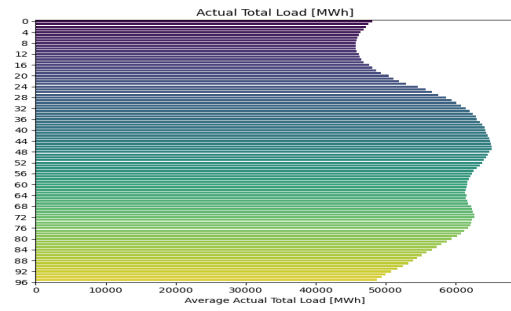

Figure 10: Germany: quarterly average Actual Total Load [MWh]

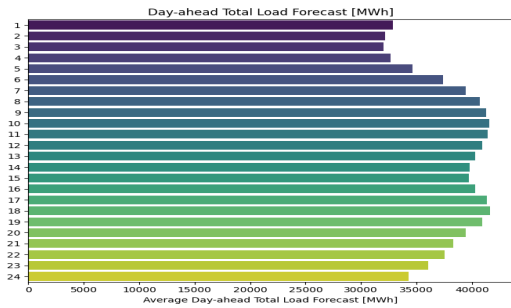

Figure 11: Belgium: hourly average Day-ahead total Load Forecast [MWh]

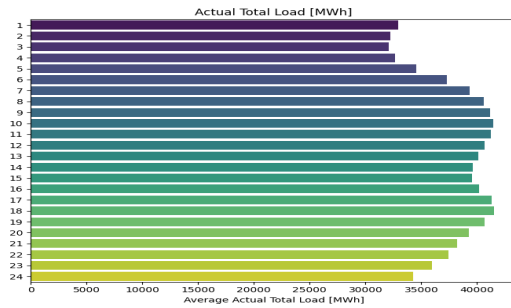

Figure 12: Belgium: hourly average Actual Total Load [MWh]

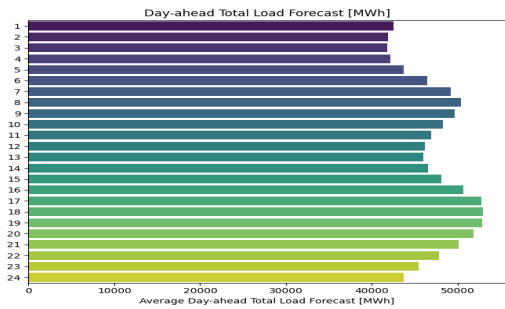

Figure 13: Netherlands: hourly average Day-ahead total Load Forecast [MWh]

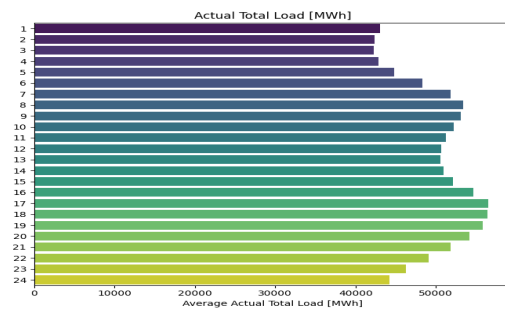

Figure 14: Netherlands: hourly average Actual Total Load [MWh]



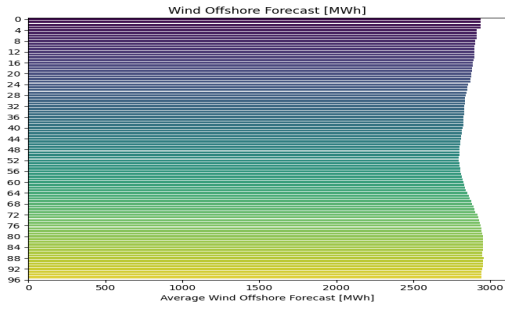

Figure 15: Germany: quarterly average Wind Offshore Forecast [MWh]

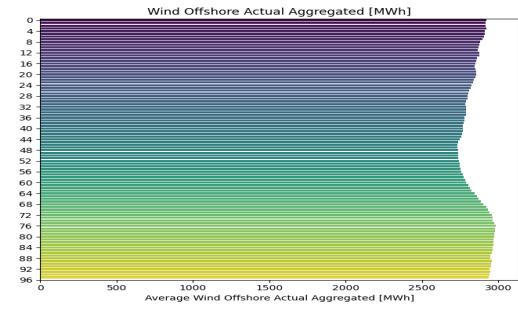

Figure 16: Germany: quarterly average Wind Offshore Actual [MWh]

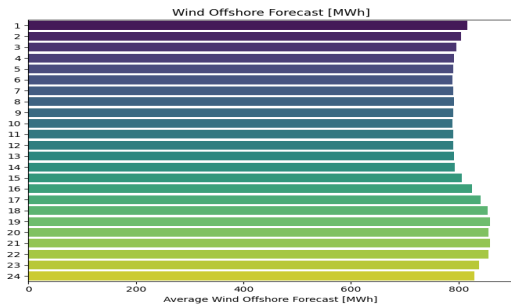

Figure 17: Belgium: hourly average Wind Offshore Forecast [MWh]

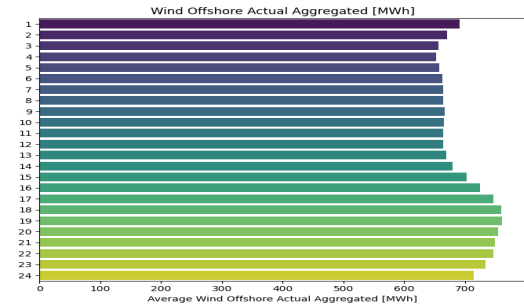

Figure 18: Belgium: hourly average Wind Offshore Actual [MWh]

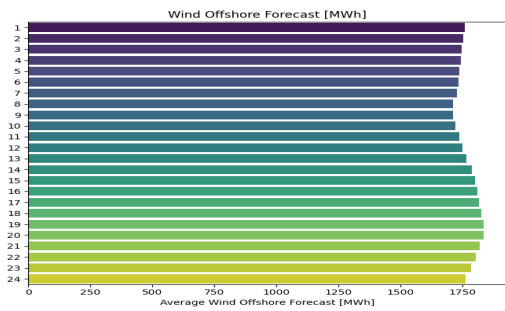

Figure 19: Netherlands: hourly average Wind Offshore Forecast [MWh]

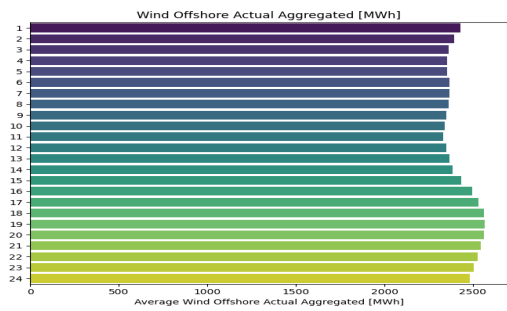

Figure 20: Netherlands: hourly average Wind Offshore Actual [MWh]

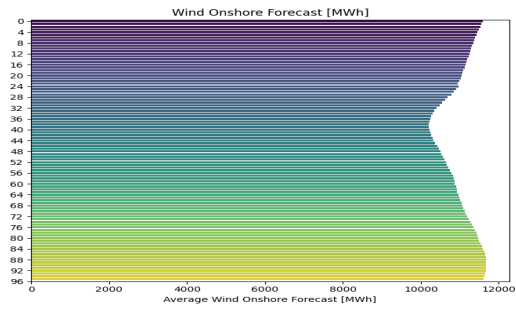

Figure 21: Germany: quarterly average Wind Onshore Forecast [MWh]

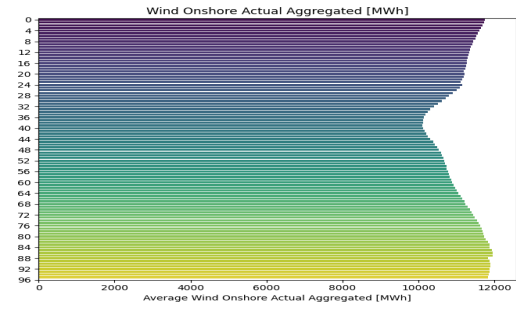

Figure 22: Germany: quarterly average Wind Onshore Actual [MWh]

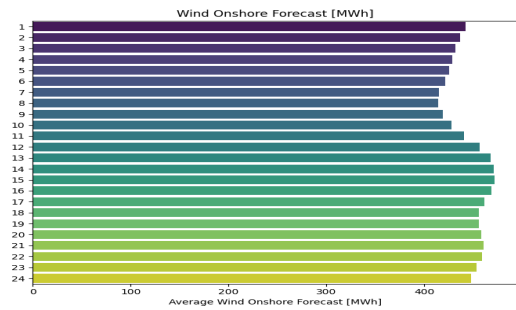

Figure 23: Belgium: hourly average Wind Onshore Forecast [MWh]

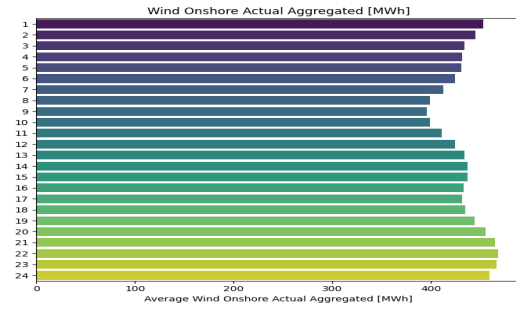

Figure 24: Belgium: hourly average Wind Onshore Actual [MWh]

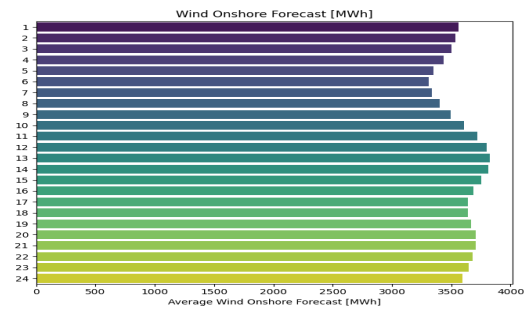

Figure 25: Netherlands: hourly average Wind Onshore Forecast [MWh]

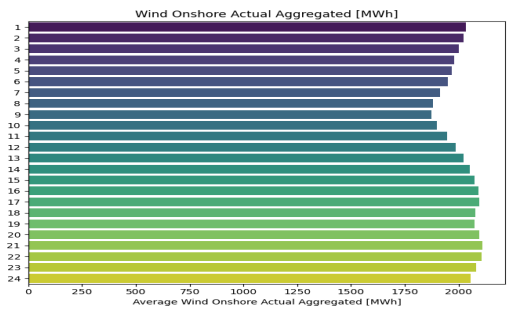

Figure 26: Netherlands: hourly average Wind Onshore Actual [MWh]

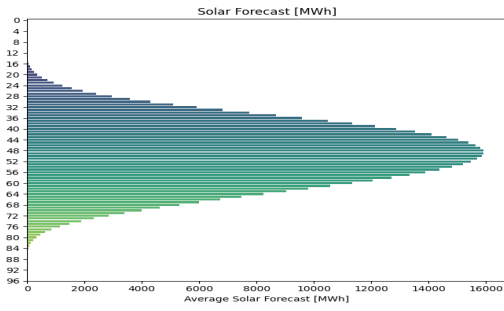

Figure 27: Germany: quarterly average Solar Forecast Production [MWh]

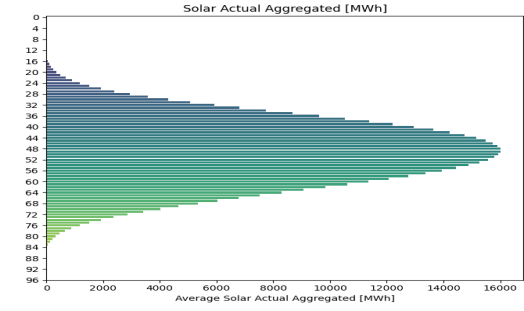

Figure 28: Germany: quarterly average Solar Actual Production [MWh]

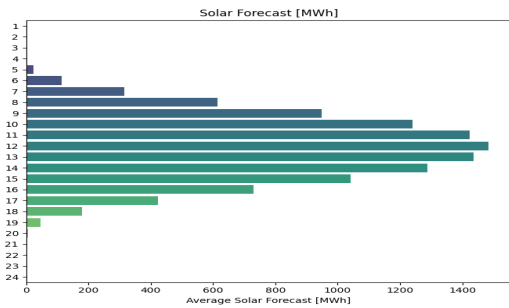

Figure 29: Belgium: hourly average Solar Forecast Production [MWh]

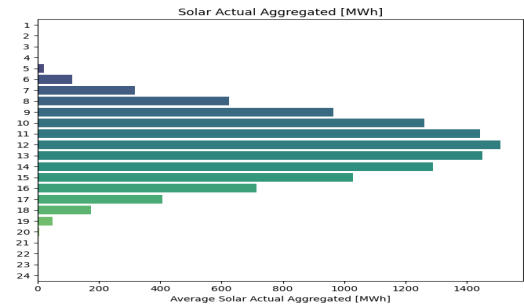

Figure 30: Belgium: hourly average Solar Actual Production [MWh]

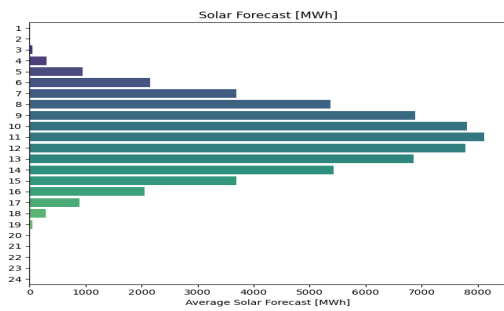

Figure 31: Netherlands: hourly average Solar Forecast Production [MWh]

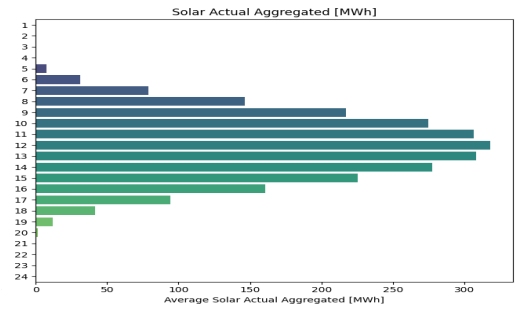

Figure 32: Netherlands: hourly average Solar Actual Production [MWh]

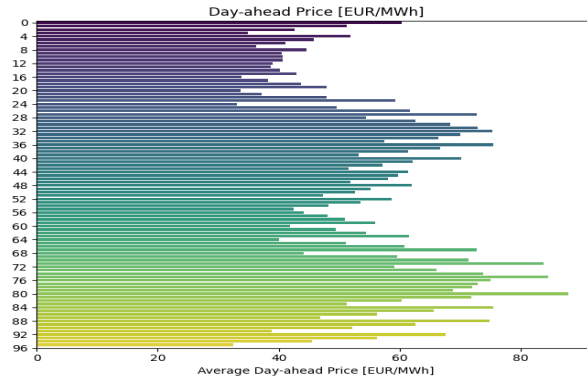

Figure 33: Germany: quarterly average Day-ahead Price [EUR/MWh]

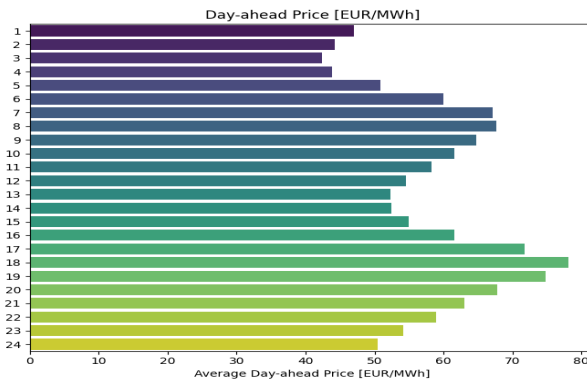

Figure 34: Belgium: hourly average Day-ahead Price [EUR/MWh]

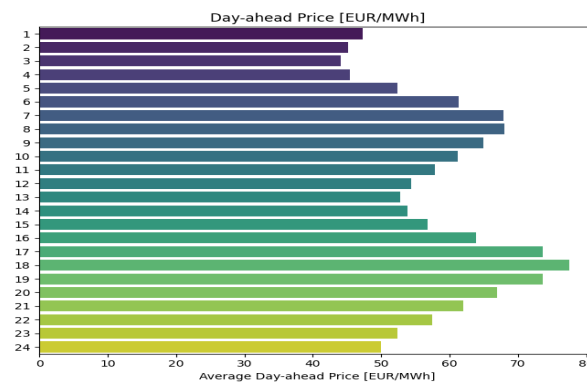

Figure 35: Netherlands: hourly average Day-ahead Price [EUR/MWh]

### 5.3 Results and Conclusions

In this section, we present the outcomes of our extensive investigation into electricity price forecasting models, focusing on their accuracy and reliability across different market conditions. We begin by detailing the results obtained from various models applied to our datasets, specifically highlighting the performance metrics for each model and comparing the clustered versus non-clustered approaches. This analysis includes visual representations to facilitate a clear understanding of the model performance trends.

We further explore the impact of significant geopolitical events, such as the Ukraine-Russia conflict and the ensuing energy crisis, on electricity prices. These events have drastically altered market dynamics and presented challenges to forecasting models, particularly in terms of maintaining accuracy over extended periods. Our analysis shows how these factors have influenced the models' performance, particularly noting the increased prediction errors as we approached the period of these events.

In addition, we discuss the implementation of transfer learning as a strategy to enhance forecasting accuracy in different market contexts. By leveraging knowledge from one market (Belgium) and applying it to another (Netherlands), we evaluate the effectiveness of this approach in improving prediction reliability.

Finally, we draw conclusions from our findings, summarizing the key insights and contributions of our study to the field of electricity price forecasting. We also suggest potential avenues for future research, aimed at addressing the limitations identified in our models and further enhancing their adaptability and accuracy in the face of evolving market conditions.

## 5.4 Results

### 5.4.1 Model Performance and Metrics

The primary objective of our experiments was to evaluate the performance of different forecasting models across three datasets (Germany, Belgium, and the Netherlands). We employed seven models: ARX, kNN, Regression Tree, Random Forest Regression, SVR, ANN-MLP, and LSTM. Each model was trained using both clustered and non-clustered approaches on the German dataset. The training process involved a rolling window methodology, starting with 30 days to predict the 31st day, incrementally increasing the window size until the dataset’s end.

The performance of these models was measured using three metrics: Mean Absolute Error (MAE), Root Mean Square Error (RMSE), and Symmetric Mean Absolute Percentage Error (sMAPE). The results are summarized in Table 4. Additionally, we provide visualizations of the performance metrics over the window sizes for the best-performing model (ANN-MLP with clustering), as illustrated in Figures 36, 37, and 38.

Metric	ARX Cluster	ARX No Cluster	kNN Cluster	kNN No Cluster	Reg. Tree Cluster	Reg. Tree No Cluster	RFR Cluster	RFR No Cluster	SVR Cluster	SVR No Cluster	ANN Cluster	ANN No Cluster	LSTM Cluster	LSTM No Cluster
<b>Minimum</b>														
MAE	3.9	3.8	4.2	4.2	<b>3.4</b>	4.4	3.6	4.3	4.0	3.9	3.7	4.3	5.1	4.5
RMSE	5.3	5.2	5.3	5.3	4.7	5.4	<b>4.6</b>	5.5	5.1	5.2	4.7	5.6	6.2	6.3
sMAPE	9.7	9.3	11.1	11.1	<b>8.3</b>	10.5	9.8	10.5	9.7	9.8	9.5	9.8	11.8	12.8
<b>Average</b>														
MAE	25.0	25.1	24.4	24.4	25.2	26.0	25.6	25.6	27.2	27.2	<b>23.2</b>	24.6	32.6	32.3
RMSE	28.4	28.4	28.0	28.0	28.7	29.6	29.0	29.2	30.6	30.7	<b>26.7</b>	28.3	36.6	36.3
sMAPE	44.7	44.8	43.7	43.7	45.5	46.9	45.7	45.8	47.6	47.7	<b>42.2</b>	44.5	65.4	63.5
<b>Standard Deviation</b>														
MAE	39.6	39.6	38.5	38.5	39.3	39.6	39.8	39.6	44.0	43.9	<b>38.2</b>	38.8	46.1	46.2
RMSE	42.6	42.6	41.9	41.9	42.5	42.8	42.9	42.8	47.0	46.9	<b>41.9</b>	42.3	49.3	49.5
sMAPE	32.0	31.9	29.6	<b>29.6</b>	31.1	31.0	31.5	30.9	35.8	35.6	30.0	30.4	44.9	44.6
<b>Median</b>														
MAE	9.7	9.8	9.8	9.8	10.3	10.9	10.3	10.5	10.1	10.2	<b>9.1</b>	9.8	14.6	14.1
RMSE	12.1	12.2	12.1	12.1	12.8	13.4	12.7	12.8	12.5	12.6	<b>11.4</b>	12.3	17.7	17.0
sMAPE	30.3	30.5	30.2	<b>30.2</b>	33.0	34.0	32.7	32.9	31.5	31.6	30.3	31.2	49.0	46.6

Table 4: Performance Metrics Pivot Table

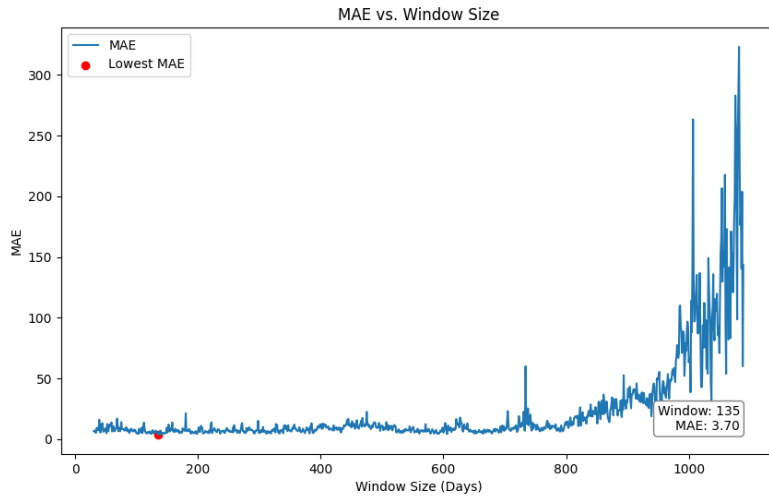

Figure 36: Mean Absolute Error (MAE) for ANN-MLP Clustered Approach

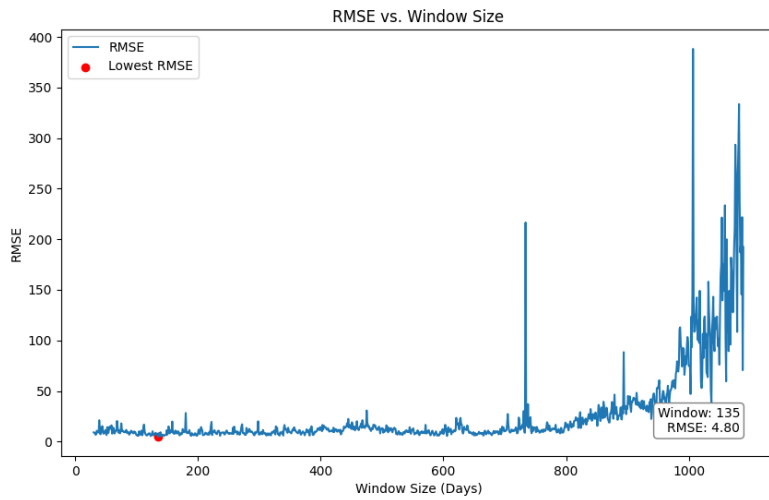

Figure 37: Root Mean Square Error (RMSE) for ANN-MLP Clustered Approach

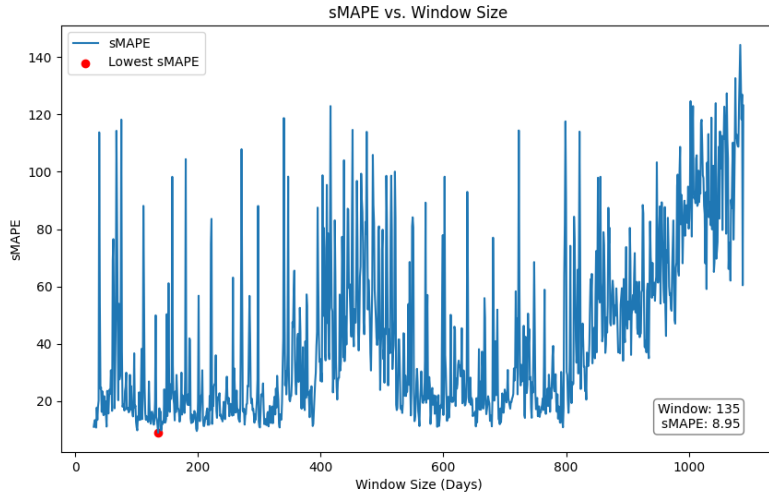

Figure 38: Symmetric Mean Absolute Percentage Error (sMAPE) for ANN-MLP Clustered Approach

The detailed results for the ANN-MLP model, including the clustering approach, indicate it was the most effective method among the tested models. These results indicate that the ANN-MLP model, particularly with the clustering approach, achieved the best overall performance across the various metrics. The clustering approach generally improved the accuracy and robustness of the models, as evidenced by the lower error rates in the clustered models compared to their non-clustered counterparts.

Analyzing the metrics in detail, we observe that the Mean Absolute Error (MAE) values for the ANN-MLP clustered approach were consistently lower than those of the other models, highlighting its superior ability to minimize absolute prediction errors. The Root Mean Square Error (RMSE) further supports this finding, showing that the ANN-MLP model effectively reduced the impact of larger errors, which is critical in ensuring more reliable and accurate predictions.

The Symmetric Mean Absolute Percentage Error (sMAPE) results also demonstrate the efficacy of the ANN-MLP clustered approach. The lower sMAPE values



indicate that this model was particularly adept at handling percentage errors, making it more reliable for predictions where relative accuracy is crucial. This is especially important in the context of electricity price forecasting, where small percentage errors can translate into significant financial implications.

The clustering approach not only enhanced the performance of the ANN-MLP model but also provided more stability and consistency across the different time windows. This stability is reflected in the lower standard deviations of the metrics for the clustered models, suggesting that the predictions were more reliable and less prone to fluctuations compared to the non-clustered models.

Moreover, the median values for MAE, RMSE, and sMAPE reinforce the overall findings, showing that the ANN-MLP clustered approach maintained superior performance not just on average but also at the median.

#### **5.4.2 Geopolitical Events and Market Dynamics**

The dataset spans from January 1, 2019, to December 31, 2021, a period marked by significant geopolitical events and their ensuing impact on electricity markets. Notably, the Ukraine-Russia conflict and the subsequent energy crisis have profoundly influenced the dynamics of electricity prices in Europe, particularly in Germany, Belgium, and the Netherlands.

Central Europe's heavy reliance on Russian energy supplies exacerbated the volatility in electricity prices. The onset of the Ukraine-Russia conflict in early 2021 triggered widespread uncertainty and market disruptions. The imposition of economic sanctions on Russia and the subsequent retaliatory measures led to significant fluctuations in energy supply and demand. These disruptions were further compounded by the broader energy crisis, characterized by sharp increases in natural gas prices and reduced energy imports from Russia.

**Impact on Model Performance** The geopolitical events and the energy crisis have had a pronounced effect on the performance of the forecasting models. As illustrated in Figures 36, 37, and 38, there is a noticeable increase in prediction errors starting around 800 days into the dataset, coinciding with the beginning of 2021. This period aligns with the escalation of geopolitical tensions and the onset of the energy crisis, highlighting the challenges faced by the models in maintaining accuracy under such volatile conditions.

The figures for the ANN-MLP clustered approach, which consistently outperformed other models, show a clear trend of increasing Mean Absolute Error (MAE), Root Mean Square Error (RMSE), and Symmetric Mean Absolute Percentage Error (sMAPE) as the window size grows. This trend underscores the difficulty in achieving precise forecasts during periods of heightened market instability.

### Analysis of Figures

- **Figure 36 (MAE vs. Window Size):** The graph demonstrates a steady increase in MAE values beyond the 800-day mark, with a sharp rise towards the end of the dataset. The lowest MAE was observed at a window size of 135 days, at 3.70, reflecting relatively stable market conditions before the geopolitical turmoil.
- **Figure 37 (RMSE vs. Window Size):** Similar to the MAE trend, the RMSE values escalate significantly beyond the 800-day window, with the lowest RMSE recorded at 4.80 for a window size of 135 days.
- **Figure 38 (sMAPE vs. Window Size):** The sMAPE values exhibit increased volatility, with the lowest sMAPE of 8.95 observed at a window size of 135 days. This indicates that percentage errors were relatively contained before the energy crisis intensified.

These results highlight the profound impact of geopolitical events on electricity price forecasting. The escalation of the Ukraine-Russia conflict and the subsequent energy crisis introduced unprecedented volatility and uncertainty into the market, challenging the predictive capabilities of even the most robust models.

**Conclusion** The analysis demonstrates that while the ANN-MLP model with clustering generally provided the best performance, the accuracy of all models was adversely affected by the geopolitical events and the energy crisis. This underscores the importance of considering external factors and incorporating adaptive mechanisms in forecasting models to better handle such unpredictable and volatile market conditions.

### 5.4.3 Transfer Learning Results

After determining that the ANN-MLP model with clustering was the best-performing model, we proceeded to evaluate the impact of transfer learning between the Belgian and Dutch datasets. The aim was to leverage the knowledge gained from the Belgian dataset to improve the predictive performance on the Dutch dataset.

**Experiment Setup** We trained an ANN-MLP model on the Belgian dataset using both clustered and non-clustered approaches. The model was then fine-tuned using the Dutch dataset to assess the benefits of transfer learning. For comparison, we also trained an ANN-MLP model solely on the Dutch dataset without using transfer learning.

**Performance Metrics** The performance metrics for these experiments, including MAE, RMSE, and sMAPE, are summarized in Table 5.

Model	MAE	Window	RMSE	Window	sMAPE	Window
Belgian MLP (No Cluster)	1.9	312	2.2	312	4.4	765
Belgian MLP (Clustered)	1.6	144	2.1	144	4.4	144
Netherlands MLP (No Cluster)	1.8	592	2.1	592	4.6	100
Netherlands MLP (Clustered)	1.0	201	1.5	201	3.2	201
Transfer Learning MLP (Clustered)	1.4	86	1.7	86	2.5	924

Table 5: Performance Metrics for Transfer Learning Experiments

**Analysis of Transfer Learning Results** The results demonstrate mixed outcomes for the transfer learning approach. The ANN-MLP model with clustering, when fine-tuned using the Dutch dataset, showed some improvements in sMAPE and achieved almost as good results regarding MAE and RMSE compared to models trained directly on the Dutch dataset.

- **Belgian Dataset Results:** The ANN-MLP model performed better with the clustering approach, showing lower minimum MAE and RMSE values, as well as comparable sMAPE.
- **Netherlands Dataset Results:** When trained directly on the Dutch dataset, the model achieved reasonable performance. The clustering approach consistently yielded better results, with notably lower MAE, RMSE, and sMAPE values.
- **Transfer Learning Results:** The transfer learning approach leveraging the Belgian dataset’s knowledge showed improvements in sMAPE and achieved competitive results for MAE and RMSE. This suggests that while transfer learning may not always produce the lowest error metrics, it can still provide efficient and reliable predictions, particularly in less time compared to training a model.

## 5.5 Conclusion

The transfer learning experiment confirms that while leveraging pre-trained models from related datasets can offer some benefits, particularly in reducing percentage errors as indicated by sMAPE, it does not necessarily guarantee lower MAE and RMSE. However, the ANN-MLP model with clustering demonstrated superior accuracy in some metrics and achieved competitive results for others.

One of the key benefits of transfer learning is the reduced training time. By starting with a model pre-trained on a related dataset, significant time and computational resources can be saved. This is particularly valuable in real-world applications where timely predictions are crucial.

In summary, although transfer learning may not always outperform models trained directly on the target dataset, it provides a practical and efficient alternative that achieves good results in a shorter time frame. These findings underscore the potential of transfer learning to enhance forecasting models in the energy market, where quick and reliable predictions are essential for decision-making and strategic planning.

## 6 Discussion and Future Work

This section aims to provide a comprehensive discussion of the implications of our findings and propose potential directions for future research. Drawing from the extensive literature reviewed in this study, we highlight key areas where further investigation could enhance the understanding and application of electricity price forecasting models. Additionally, we outline potential improvements to the methodologies employed in this study, leveraging insights from related fields and emerging technologies.

### 6.1 Implications of Findings

The results of our study underscore the efficacy of advanced machine learning models, particularly the ANN-MLP with clustering, in accurately forecasting electricity prices. Despite the challenges posed by recent geopolitical events such as the Ukraine-Russia conflict and the energy crisis, our models demonstrated robust performance. The clustering approach, in particular, proved beneficial in enhancing the accuracy and reliability of predictions.

Our findings align with those of Weron (2014) [1], who highlighted the potential of machine learning techniques in electricity price forecasting. Furthermore, the success of the ANN-MLP model echoes the insights of Goodfellow et al. (2016) [2] on the power of deep learning in handling complex, nonlinear relationships inherent in time series data. The integration of exogenous variables, as discussed by Papalexopoulos and Hesterberg (1990) [18], also played a crucial role in improving model performance.

### 6.2 Limitations and Challenges

While our models achieved commendable results, several limitations warrant attention. The sensitivity of machine learning models to data quality and preprocess-

ing steps is a critical factor influencing their performance. Additionally, the transfer learning approach, although promising, did not consistently outperform models trained directly on the target dataset. This highlights the need for further refinement and optimization of transfer learning techniques in this domain.

The geopolitical events during our dataset's span introduced significant volatility and uncertainty, complicating the forecasting process. As observed by Benth et al. (2018) [22], market disruptions can lead to substantial deviations in electricity prices, challenging the predictive capabilities of even the most advanced models.

### 6.3 Future Research Directions

Building on our findings, several avenues for future research can be pursued:

1. **Enhanced Transfer Learning Techniques:** Investigating more sophisticated transfer learning frameworks could yield better results. Techniques such as domain adaptation and multi-task learning might improve the ability of models to generalize across different markets and conditions.
2. **Integration of Additional Exogenous Variables:** Incorporating a broader range of exogenous factors, such as geopolitical indicators, economic indices, and weather patterns, could further enhance model accuracy. The work of Hyndman and Athanasopoulos (2018) [4] on time series forecasting principles suggests that a comprehensive set of predictors can significantly improve forecasts.
3. **Hybrid Models:** Developing hybrid models that combine the strengths of various machine learning and statistical techniques could offer a more robust solution. For instance, integrating ARIMA with deep learning models, as explored by Conejo et al. (2005) [15], could leverage the advantages of both approaches.

4. **Real-time Forecasting and Adaptation:** Implementing real-time forecasting systems that continuously update and adapt to new data could improve the responsiveness and accuracy of predictions. Advances in streaming data processing and online learning algorithms could facilitate this approach.
5. **Explainability and Interpretability:** Enhancing the interpretability of machine learning models is crucial for gaining trust and acceptance among stakeholders. Techniques such as those proposed by Ribeiro et al. (2016) [23] for explaining model predictions can be applied to electricity price forecasting models.
6. **Impact of Renewable Energy Sources:** As the integration of renewable energy sources continues to grow, studying their impact on electricity price dynamics becomes increasingly important. Sioshansi (2014) [11] discusses the challenges and opportunities associated with renewable energy integration, which could inform future forecasting models.

## 6.4 Conclusion

The advancements in machine learning and time series analysis present significant opportunities for improving electricity price forecasting. Our study highlights the potential of the ANN-MLP model with clustering and emphasizes the importance of considering geopolitical factors in forecasting models. While challenges remain, the proposed future research directions offer a roadmap for further enhancing the accuracy and applicability of these models in dynamic and volatile energy markets.

By leveraging the insights from the literature and our experimental findings, we can continue to refine and improve electricity price forecasting models, contributing to more efficient and reliable energy markets.



## References

- [1] Weron, R. (2014). Electricity price forecasting: A review of the state-of-the-art with a look into the future. *International Journal of Forecasting*, **30**(4), 1030-1081.
- [2] Goodfellow, I., Bengio, Y., & Courville, A. (2016). *Deep Learning*. MIT Press.
- [3] Kantz, H., & Schreiber, T. (2004). *Nonlinear Time Series Analysis*. Cambridge University Press.
- [4] Hyndman, R.J., & Athanasopoulos, G. (2018). *Forecasting: Principles and Practice*. OTexts.
- [5] Debnath, R., & Mourshed, M. (2018). Forecasting methods in energy-related applications. *Applied Energy*, **220**, 545-556.
- [6] Mandelbrot, B. (1983). *The Fractal Geometry of Nature*. W. H. Freeman and Company.
- [7] Lütkepohl, H. (2005). *New Introduction to Multiple Time Series Analysis*. Springer.
- [8] Brockwell, P.J., & Davis, R.A. (2002). *Introduction to Time Series and Forecasting*. Springer.
- [9] Gneiting, T., & Raftery, A.E. (2007). Strictly Proper Scoring Rules, Prediction, and Estimation. *Journal of the American Statistical Association*, **102**(477), 359-378.
- [10] Kirschen, D.S., & Strbac, G. (2004). *Fundamentals of Power System Economics*. John Wiley & Sons.

- [11] Sioshansi, F.P. (2014). *Integration of Renewable and Distributed Energy Resources*. Elsevier.
- [12] Doshi-Velez, F., & Kim, B. (2017). Towards A Rigorous Science of Interpretable Machine Learning. arXiv preprint arXiv:1702.08608.
- [13] Varian, H.R. (2014). Big Data: New Tricks for Econometrics. *Journal of Economic Perspectives*, **28**(2), 3-28.
- [14] James, G., Witten, D., Hastie, T., & Tibshirani, R. (2013). *An Introduction to Statistical Learning*. Springer.
- [15] Conejo, A. J., Plazas, M. A., Espinola, R., & Molina, A. B. (2005). Day-ahead electricity price forecasting using the wavelet transform and ARIMA models. *IEEE Transactions on Power Systems*, **20**(2), 1035-1042.
- [16] Amjady, N., & Keynia, F. (2010). A new hybrid forecast method for price and load forecasting of electricity markets. *IEEE Transactions on Power Systems*, **25**(3), 1519-1529.
- [17] Yang, L., Cui, H., Bassi, H., & Zhu, Z. (2017). Electricity price forecasting with confidence-interval estimation through an extended ARIMA approach. *IEEE Transactions on Power Systems*, **32**(1), 335-344.
- [18] Papalexopoulos, A. D., & Hesterberg, T. C. (1990). A regression-based approach to short-term load forecasting. *IEEE Transactions on Power Systems*, **5**(4), 1535-1550.
- [19] Serletis, A., & Andreadis, I. (2004). Random fractal structures in North American energy markets. *Energy Economics*, **26**(3), 389-399.

- [20] Hochreiter, S., & Schmidhuber, J. (1997). Long short-term memory. *Neural Computation*, **9**(8), 1735-1780.
- [21] Siami-Namini, S., & Namin, A. S. (2018). A comparison of ARIMA and LSTM in forecasting time series. 17th IEEE International Conference on Machine Learning and Applications (ICMLA).
- [22] Benth, F. E., Kiesel, R., & Nazarova, A. (2018). A critical look at electricity price formation in deregulated markets. *Energy Economics*, **70**, 153-167.
- [23] Ribeiro, M.T., Singh, S., & Guestrin, C. (2016). "Why Should I Trust You?" Explaining the Predictions of Any Classifier. In *Proceedings of the 22nd ACM SIGKDD International Conference on Knowledge Discovery and Data Mining* (pp. 1135-1144).
- [24] ResearchGate. (2024). An Illustration of the KNN algorithm. Retrieved from [https://www.researchgate.net/figure/An-Illustration-of-the-KNN-algorithm\\_fig4\\_360554845](https://www.researchgate.net/figure/An-Illustration-of-the-KNN-algorithm_fig4_360554845)
- [25] ResearchGate. (2024). Artificial neural network architecture (ANN). Retrieved from [https://www.researchgate.net/figure/Artificial-neural-network-architecture-ANN-i-h-1-h-2-h-n-o\\_fig1\\_321259051](https://www.researchgate.net/figure/Artificial-neural-network-architecture-ANN-i-h-1-h-2-h-n-o_fig1_321259051)
- [26] ResearchGate. (2024). The structure of Long Short-Term Memory Neural Network (LSTM). Retrieved from [https://www.researchgate.net/figure/The-structure-of-Long-Short-Term-Memory-Neural-Network-LSTM\\_fig2\\_341870314](https://www.researchgate.net/figure/The-structure-of-Long-Short-Term-Memory-Neural-Network-LSTM_fig2_341870314)
- [27] ResearchGate. (2024). Activation Functions in ANN. Retrieved from <https://www.researchgate.net/figure/>

Activation-Functions-in-ANN-Source-Google-Images-2019\_fig3\_  
338014968

[28] ResearchGate. (2024). Visual representation of Random Forest regression. Retrieved from [https://www.researchgate.net/figure/Visual-representation-of-Random-Forest-regression-from-7\\_fig3\\_364542925](https://www.researchgate.net/figure/Visual-representation-of-Random-Forest-regression-from-7_fig3_364542925)

[29] ResearchGate. (2024). Structure of support vector regression (SVR). Retrieved from [https://www.researchgate.net/figure/Structure-of-support-vector-regression-SVR-The-basic-principle-of-SVR-is-to-map\\_fig1\\_358412782](https://www.researchgate.net/figure/Structure-of-support-vector-regression-SVR-The-basic-principle-of-SVR-is-to-map_fig1_358412782)

[30] ResearchGate. (2024). Illustration of transfer learning. Retrieved from [https://www.researchgate.net/figure/Illustration-of-transfer-learning\\_fig4\\_364525211](https://www.researchgate.net/figure/Illustration-of-transfer-learning_fig4_364525211)