

APPENDIX B

Accelerations and Inter – storey Drifts for the Full Sequence of Seismic Motions

Original Building

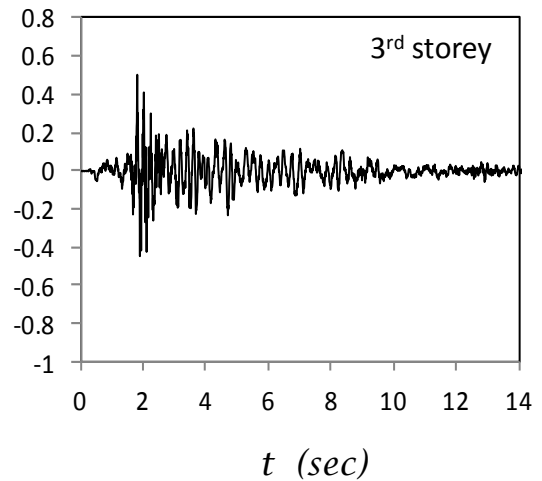
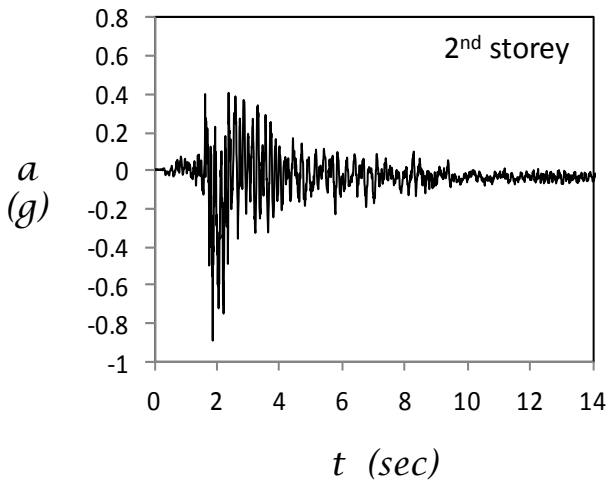
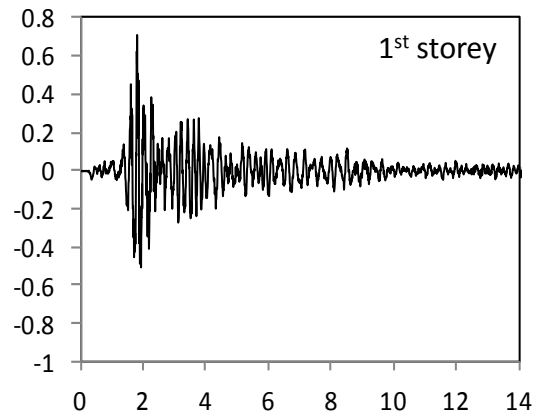
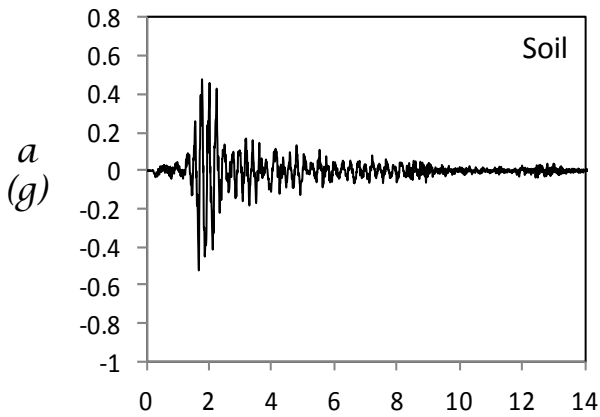
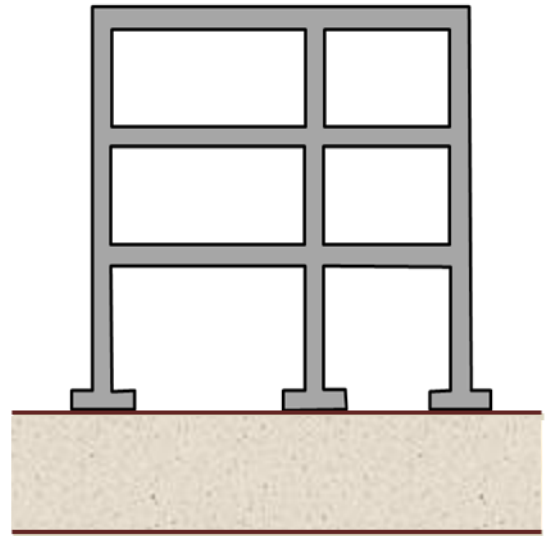
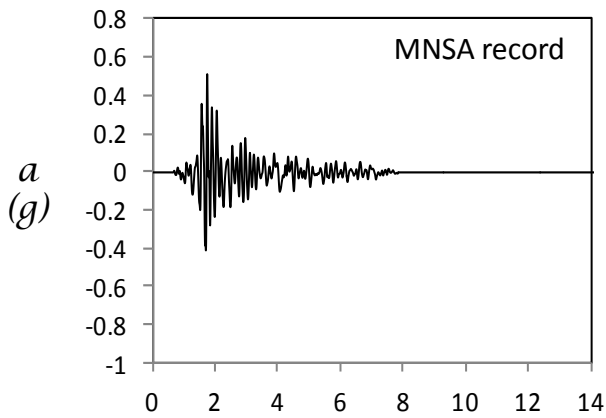

Figure B1. Acceleration time histories measured on the original building while submitted to the record of MNSA.

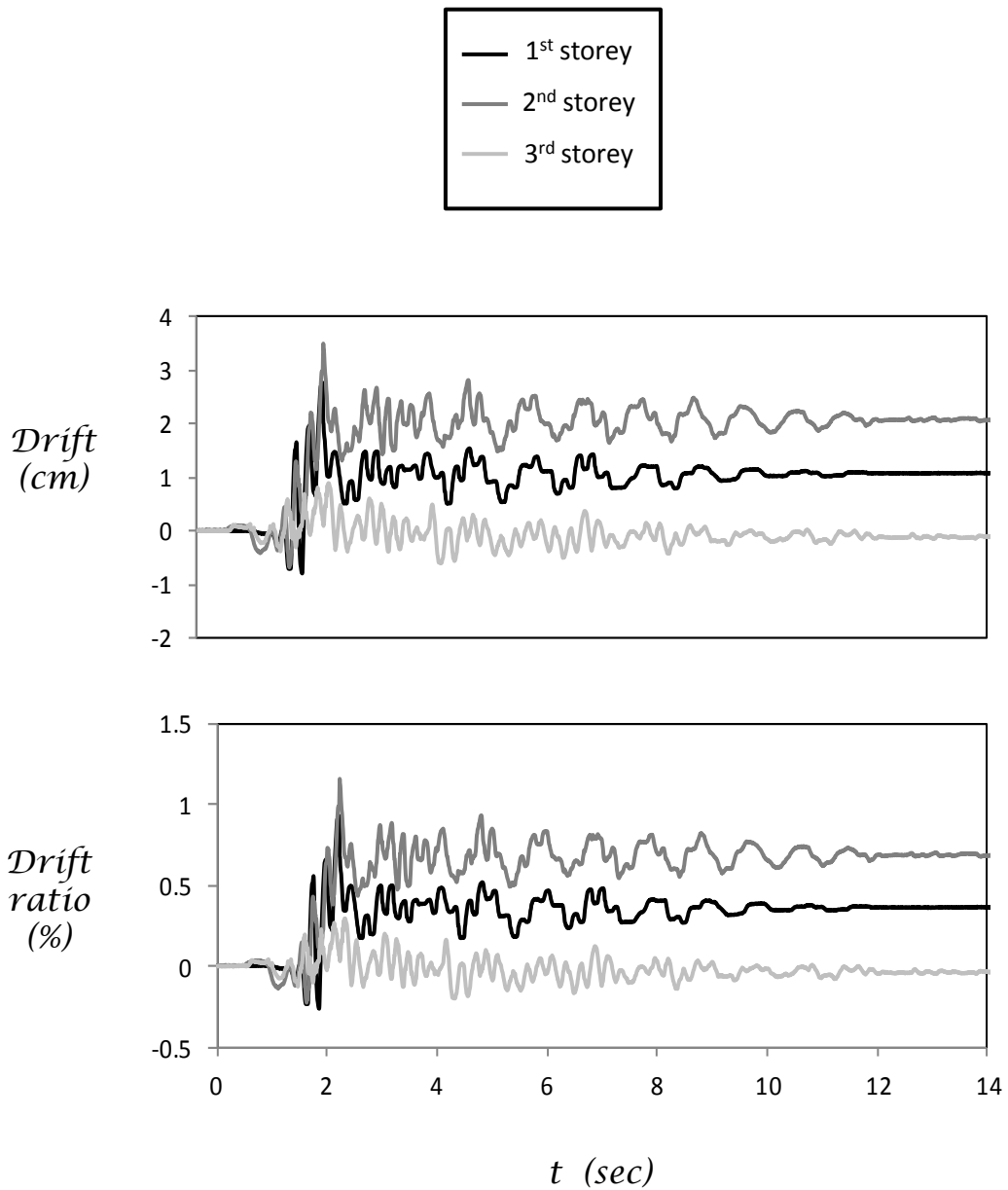
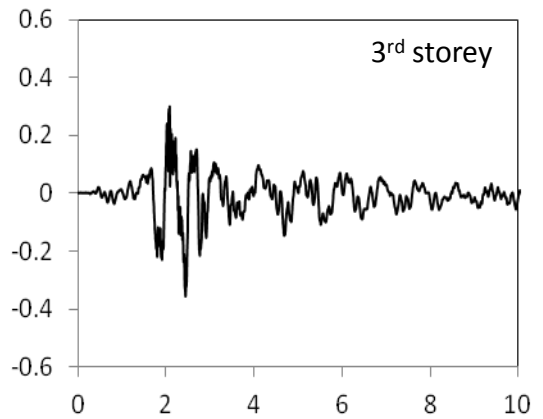
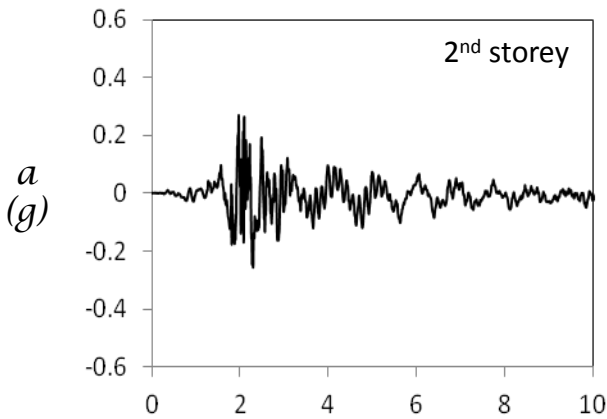
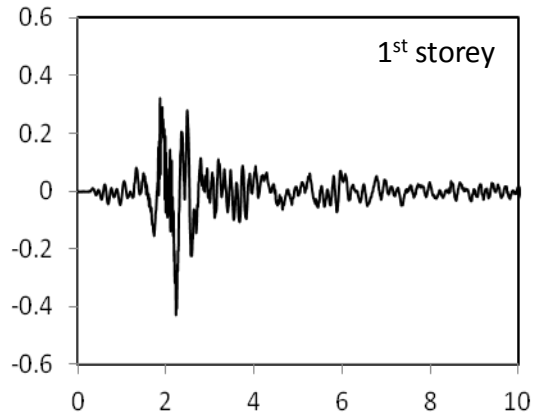
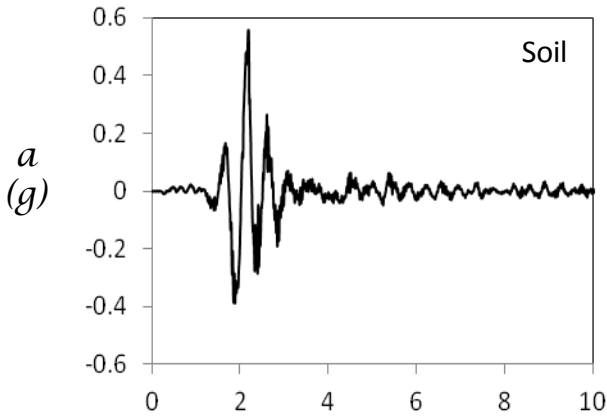
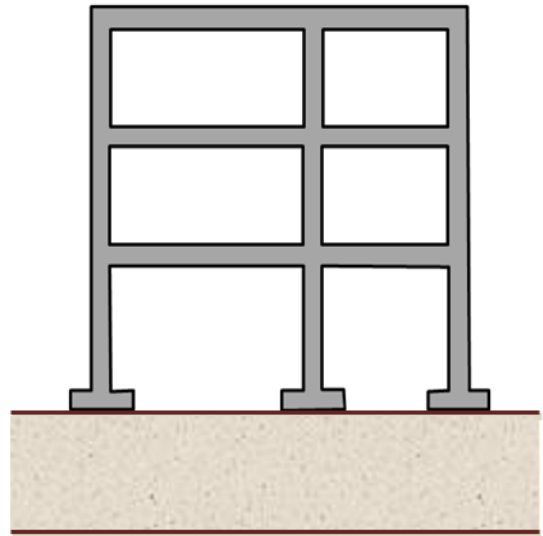
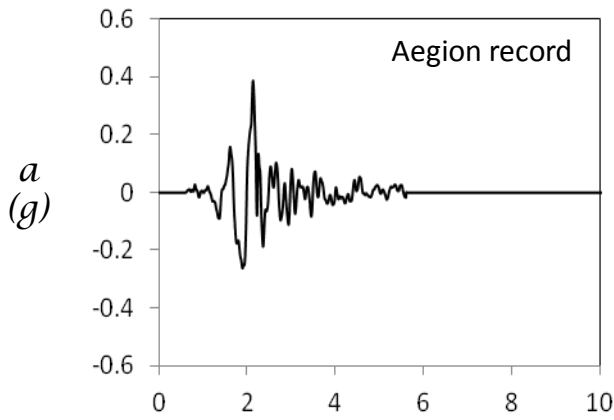

Figure B2. Time histories of storey drift and drift ratio of original building while submitted to the record of MNSA.



t (sec)

t (sec)

Figure B3. Acceleration time histories measured on the original building while submitted to the record of Aegion.

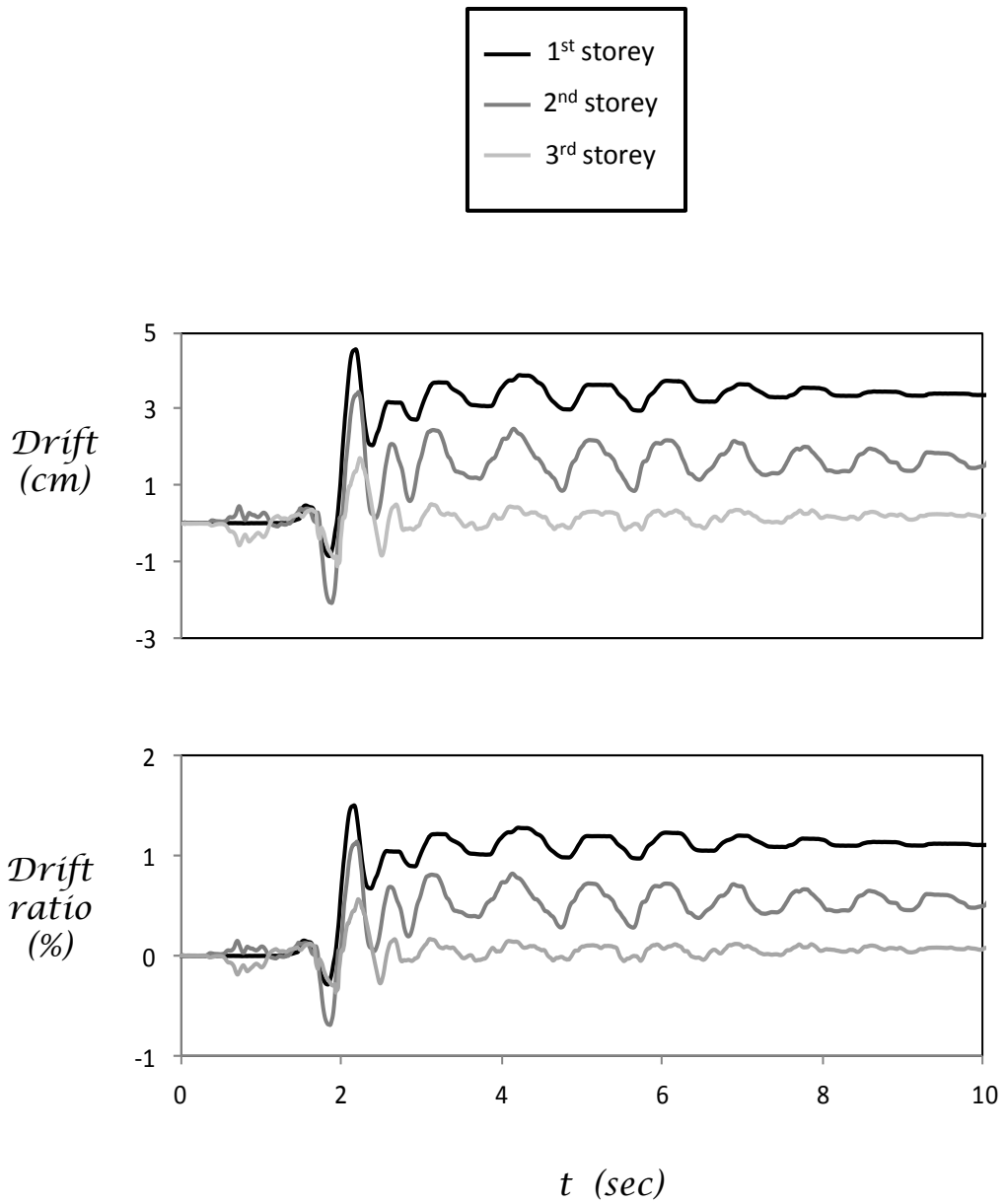
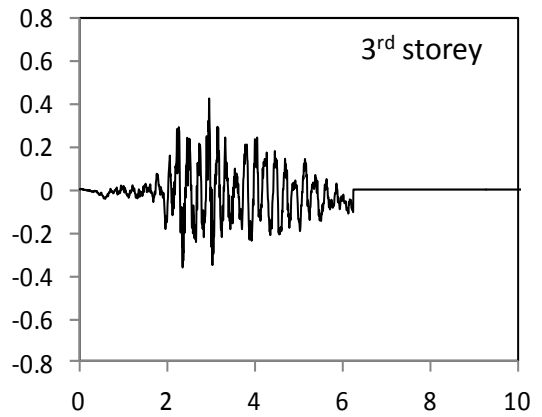
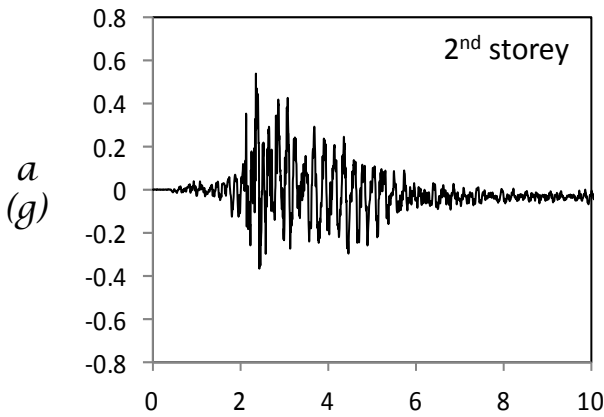
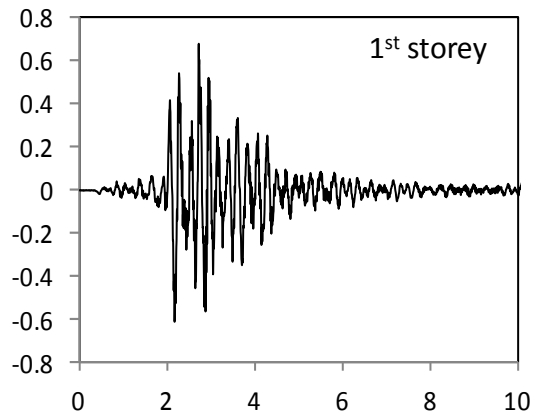
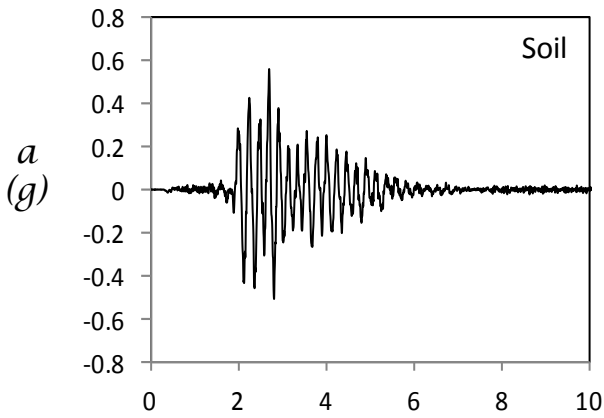
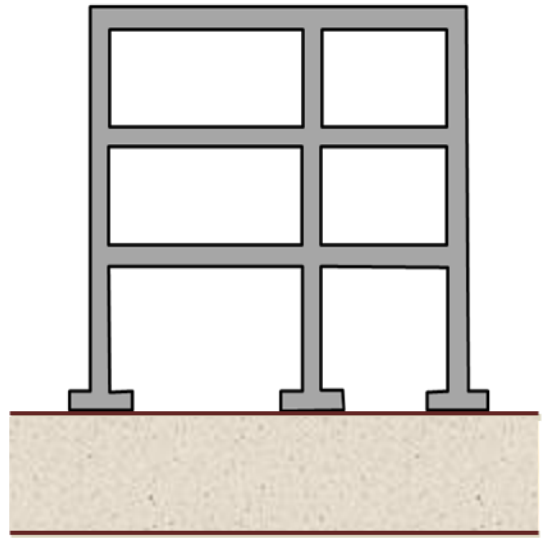
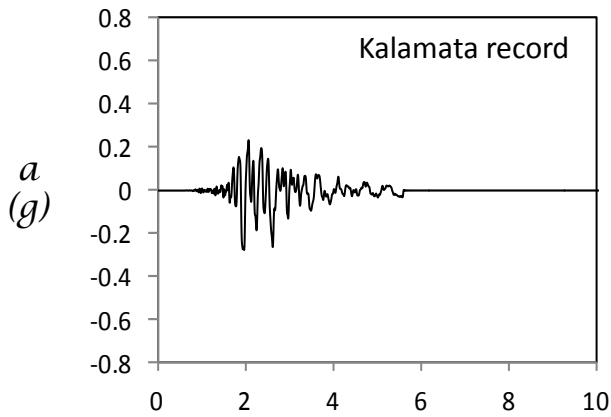

Figure B4. Time histories of storey drift and drift ratio of original building while submitted to the record of Aegion.



t (sec)

t (sec)

Figure B5. Acceleration time histories measured on the original building while submitted to the record of Kalamata.

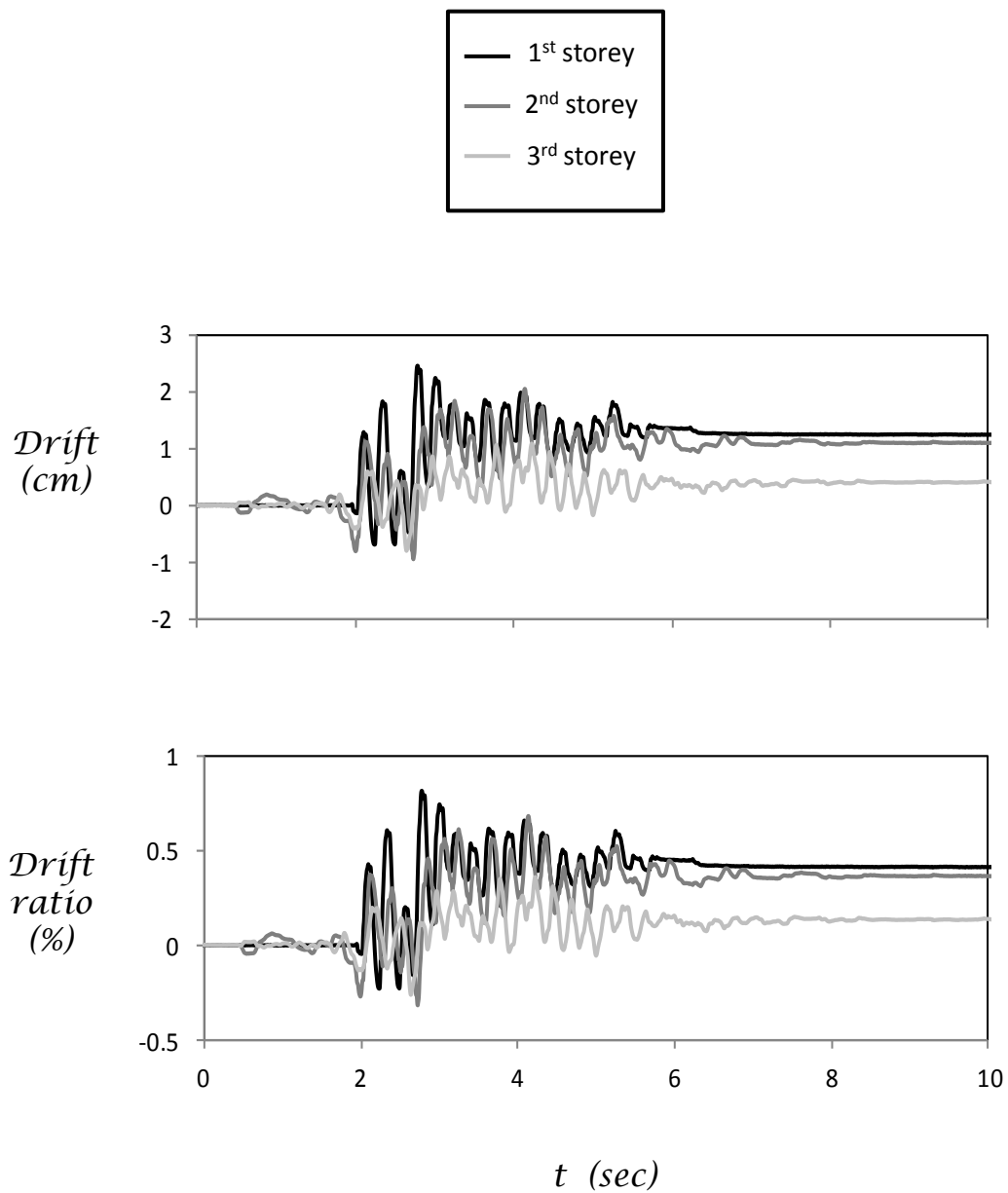

Figure B6. Time histories of storey drift and drift ratio of original building while submitted to the record of Kalamata.

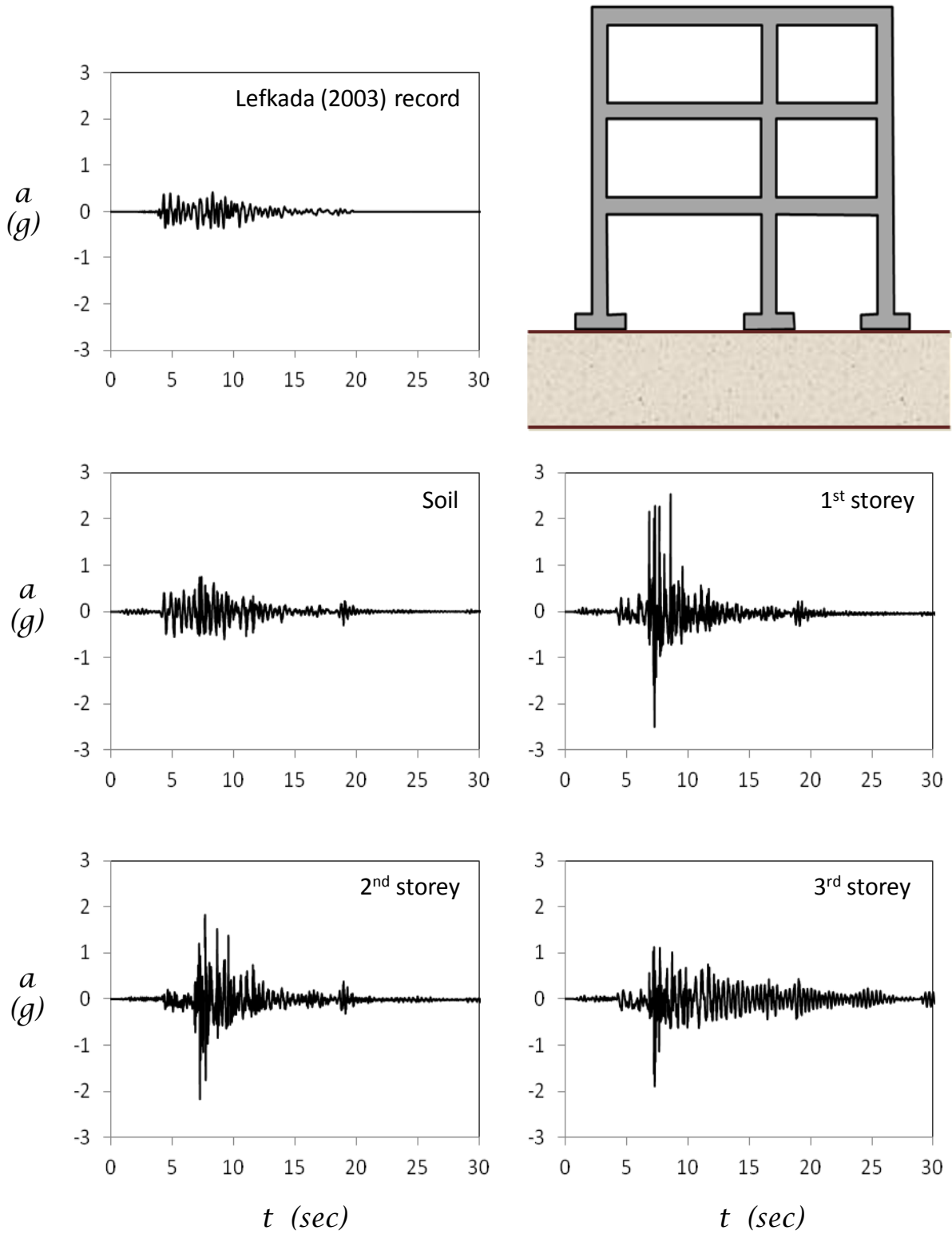

Figure B7. Acceleration time histories measured on the original building while submitted to the record of Lefkada (2003).

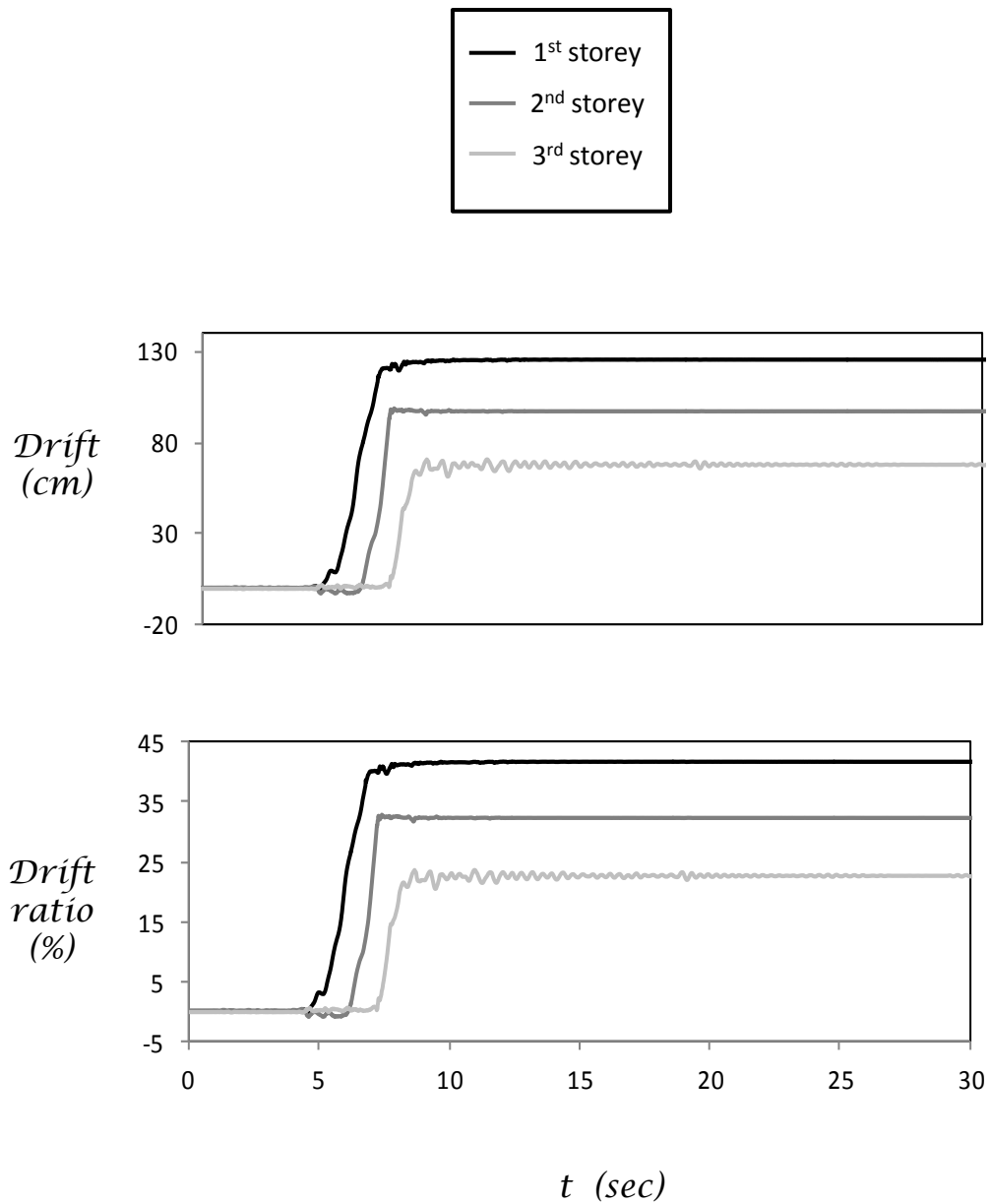

Figure B8. Time histories of storey drift and drift ratio of original building while submitted to the record of Lefkada (2003).

Retrofitted Building:

Conventional Foundation

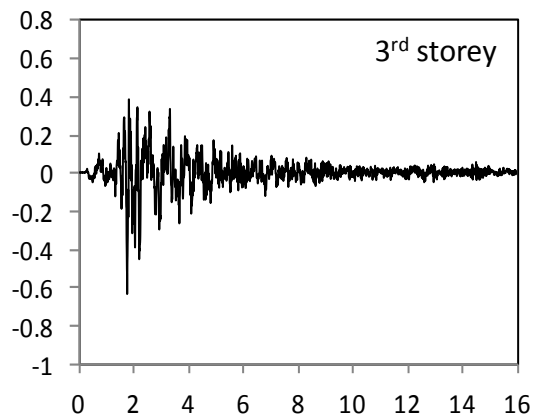
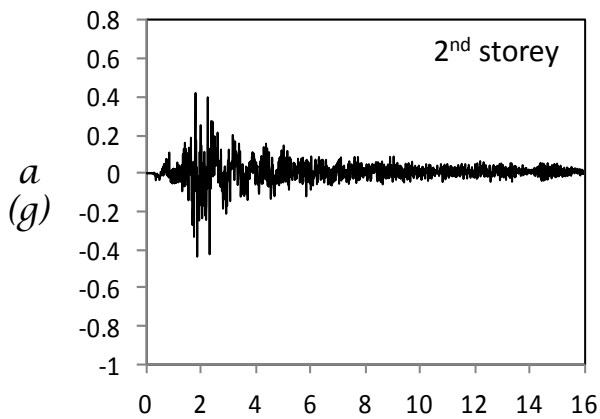
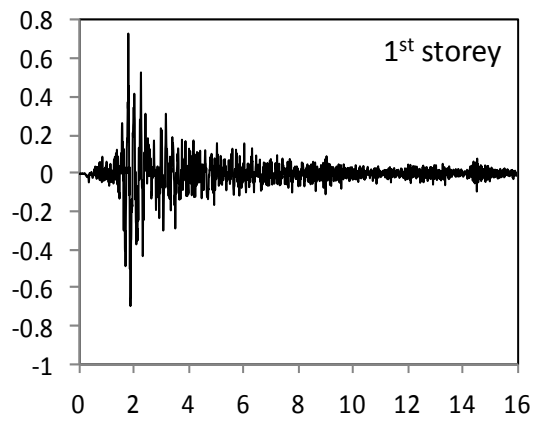
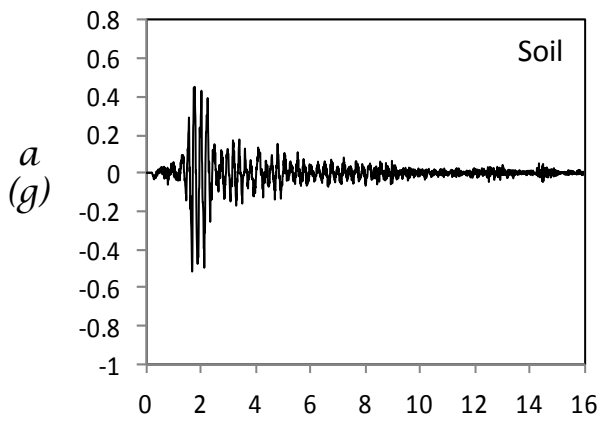
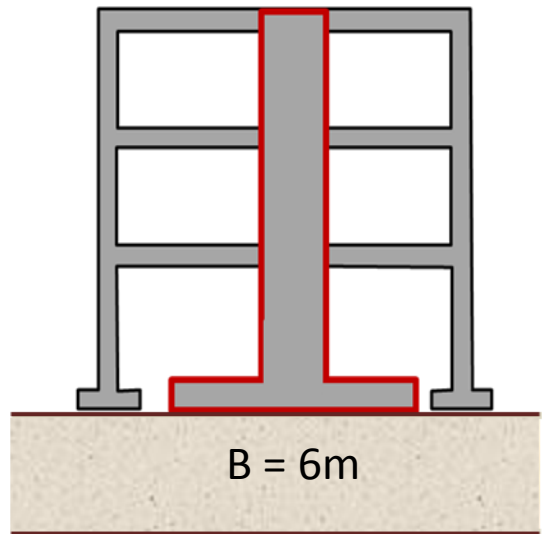
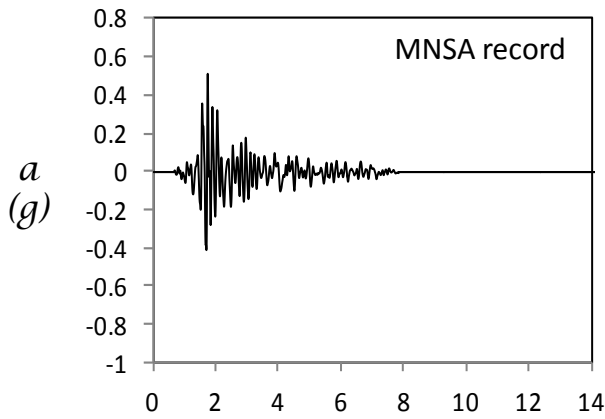

Figure B9. Acceleration time histories measured on the retrofitted building with conventional foundation ($B = 6\text{m}$) while submitted to the record of MNSA.

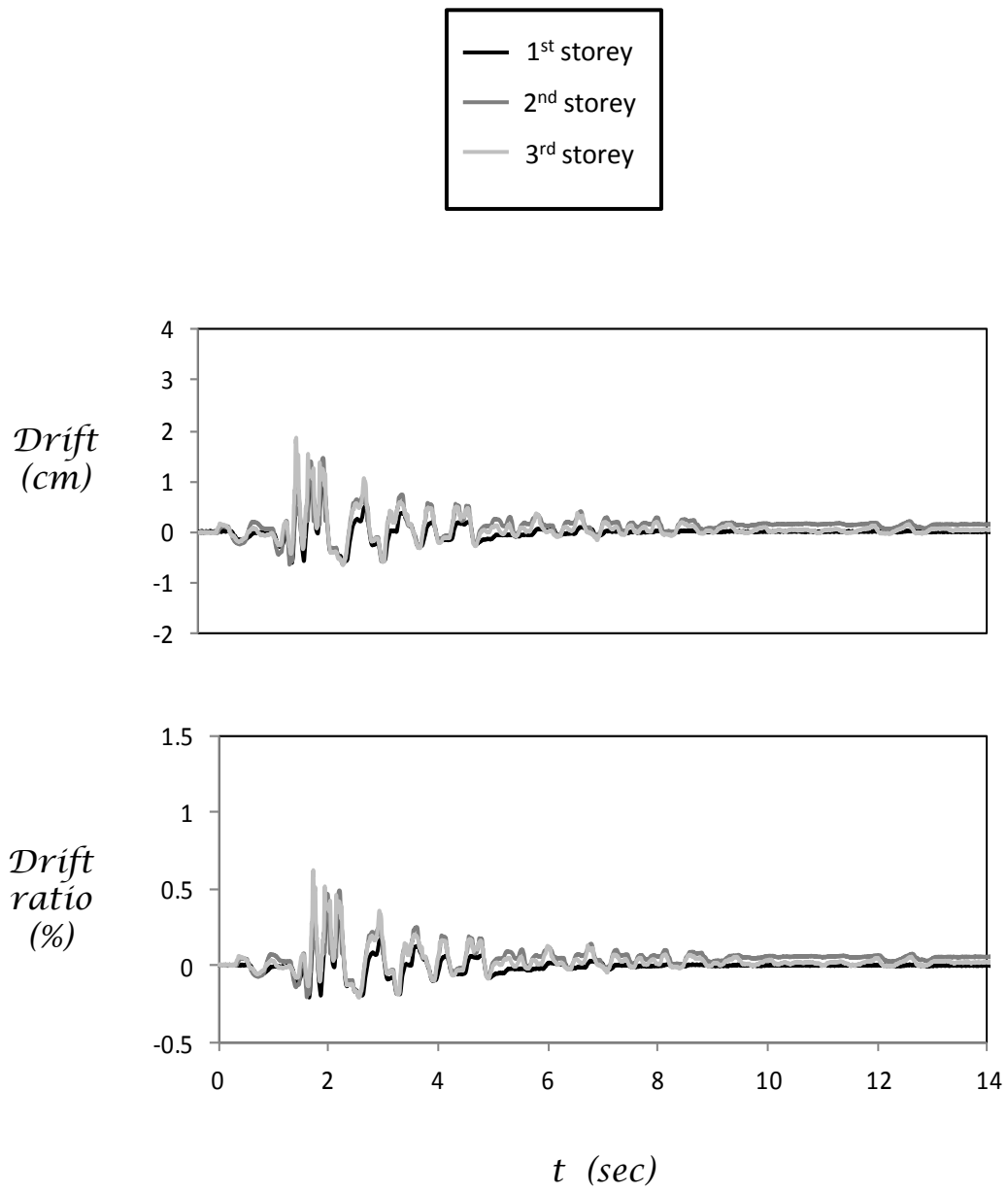

Figure B10. Time histories of storey drift and drift ratio of retrofitted building with conventional foundation ($B = 6\text{m}$) while submitted to the record of MNSA.

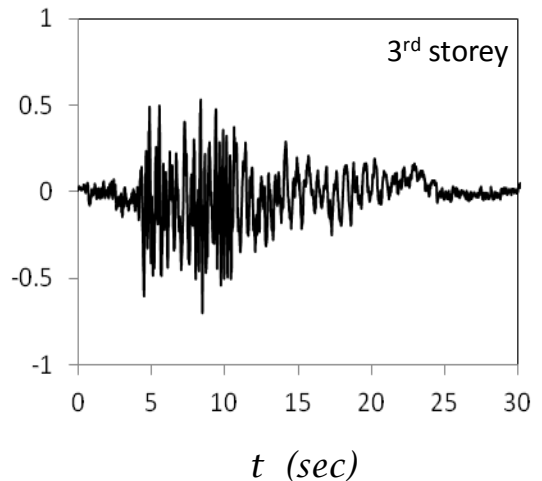
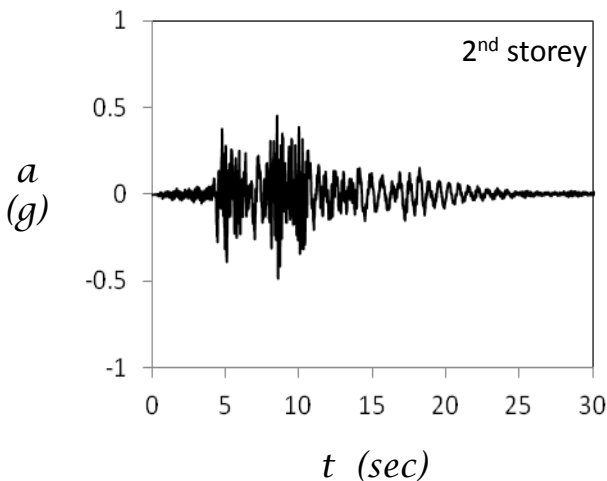
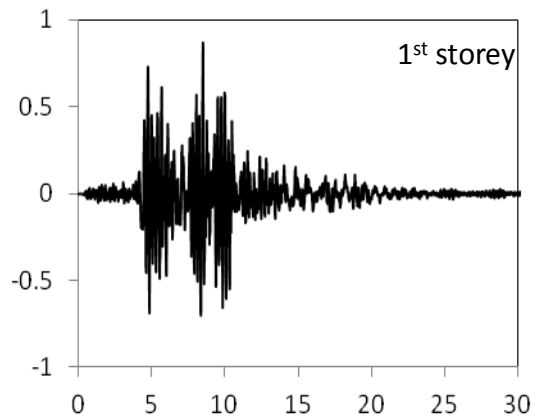
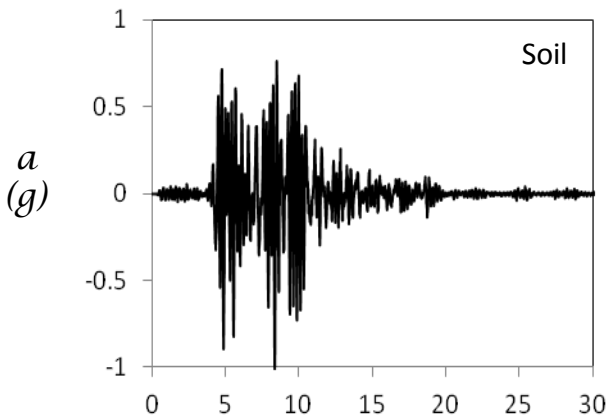
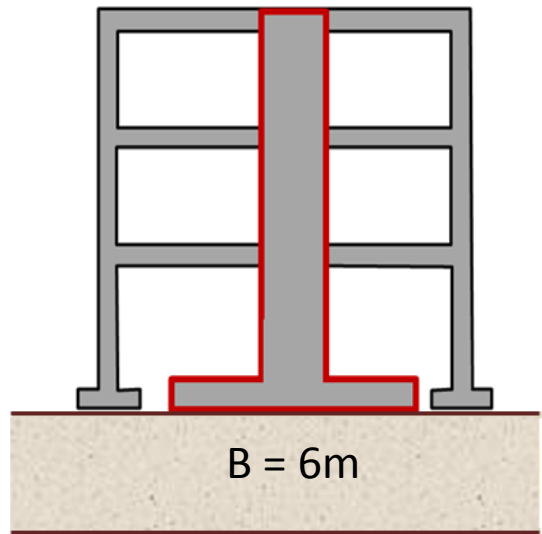
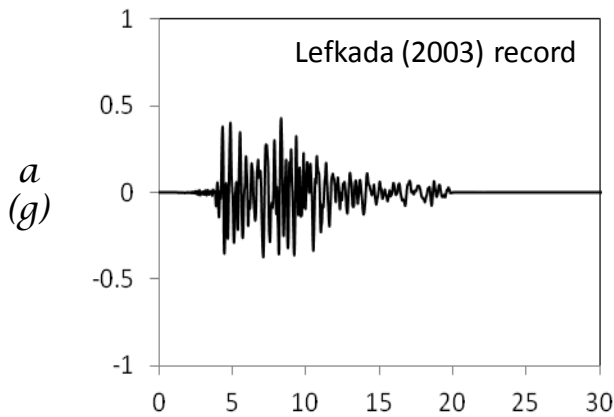

Figure B11. Acceleration time histories measured on the retrofitted building with conventional foundation ($B = 6\text{m}$) while submitted to the record of Lefkada (2003).

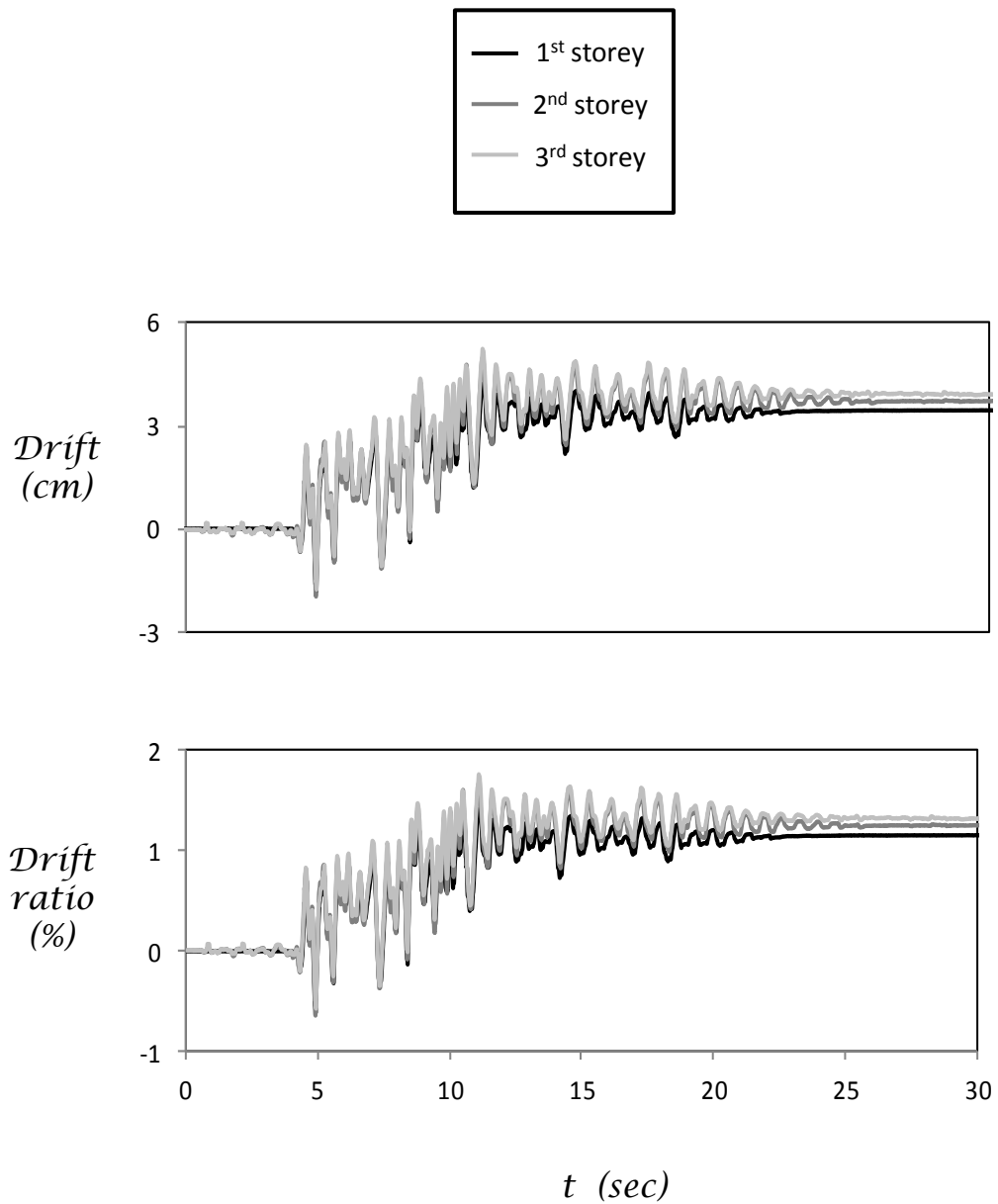

Figure B12. Time histories of storey drift and drift ratio of retrofitted building with conventional foundation ($B = 6\text{m}$) while submitted to the record of Lefkada (2003).

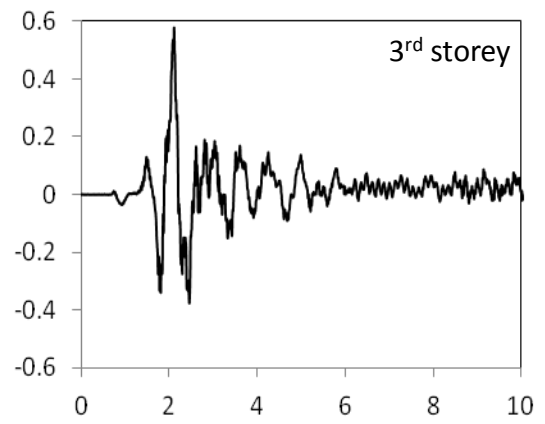
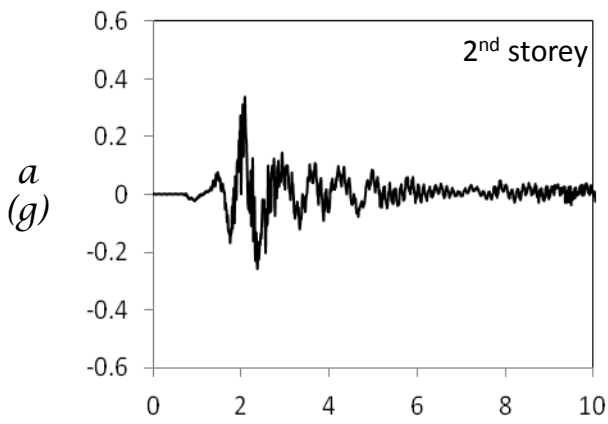
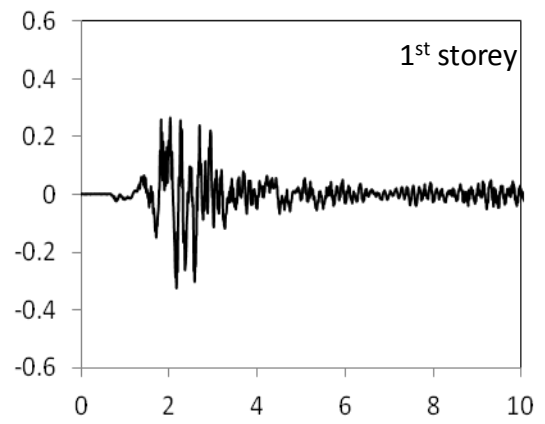
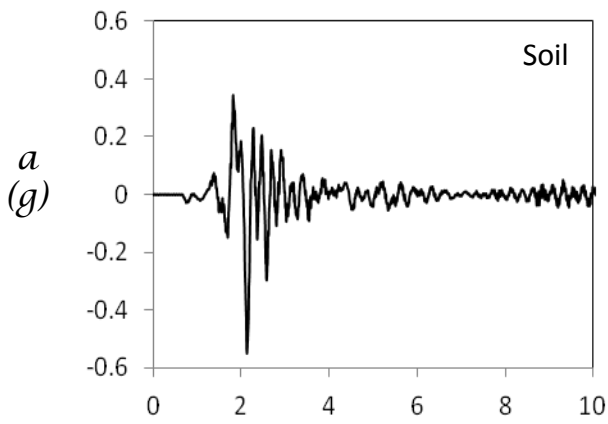
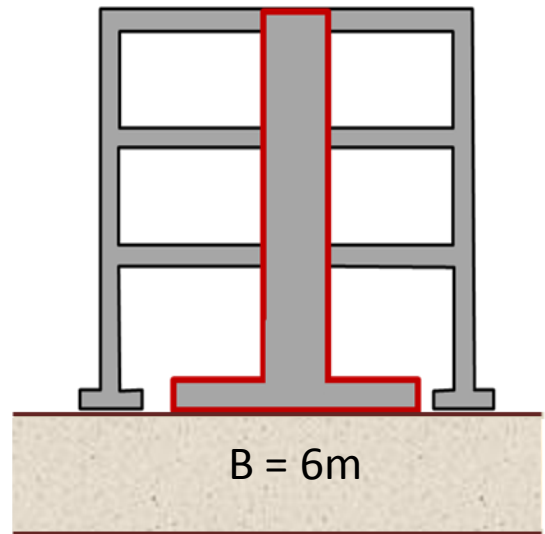
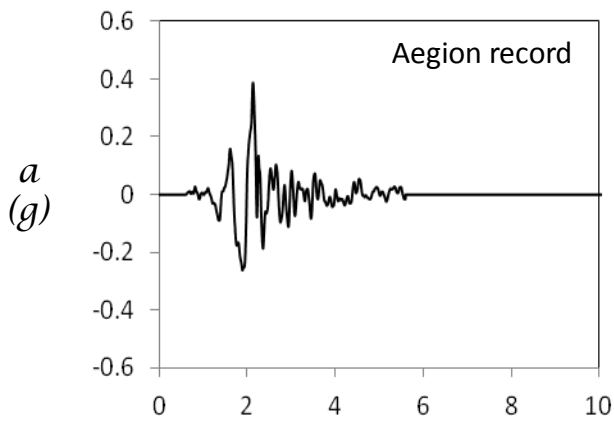

Figure B13. Acceleration time histories measured on the retrofitted building with conventional foundation ($B = 6\text{m}$) while submitted to the record of Aegion.

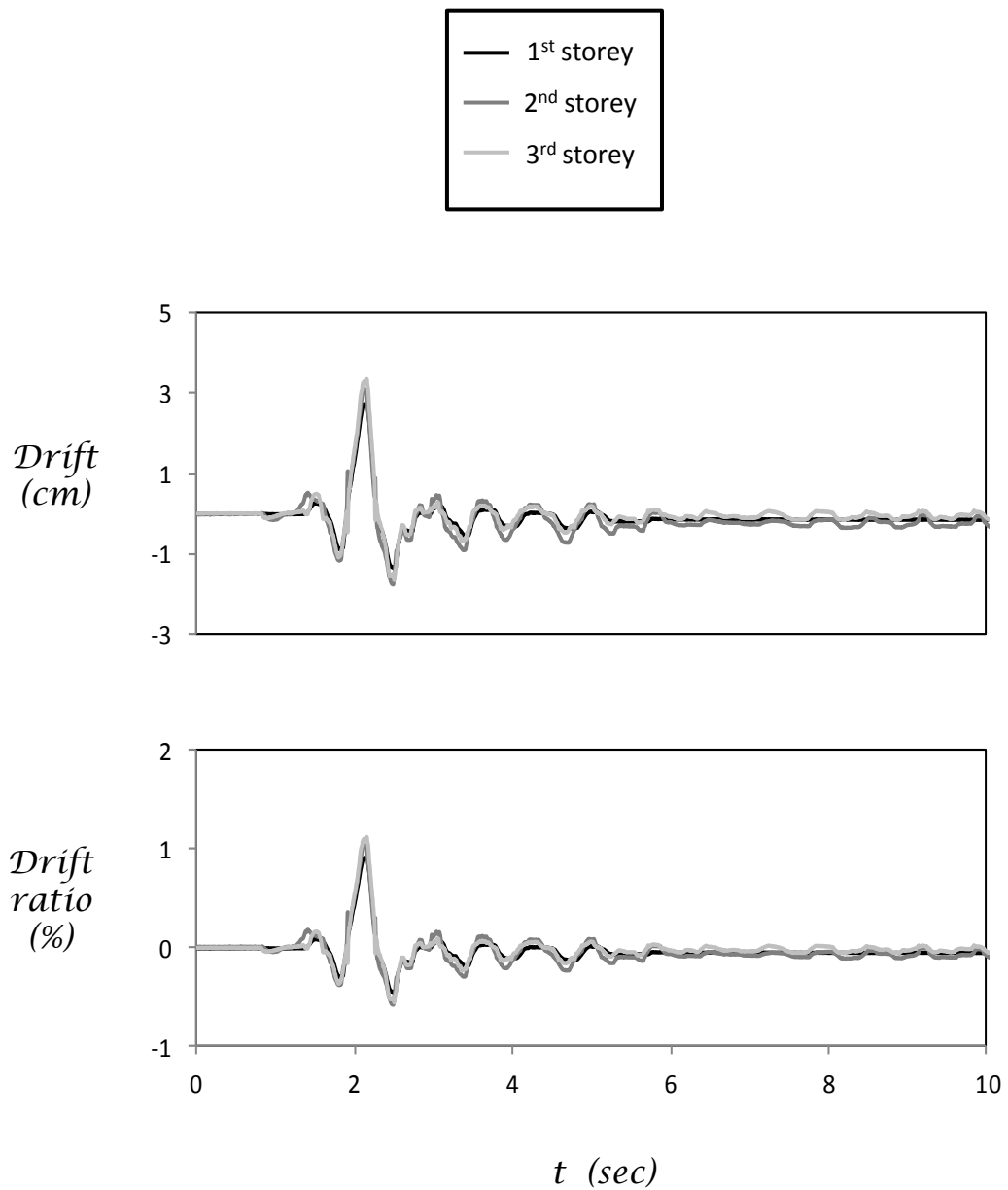

Figure B14. Time histories of storey drift and drift ratio of retrofitted building with conventional foundation ($B = 6\text{m}$) while submitted to the record of Aegion.

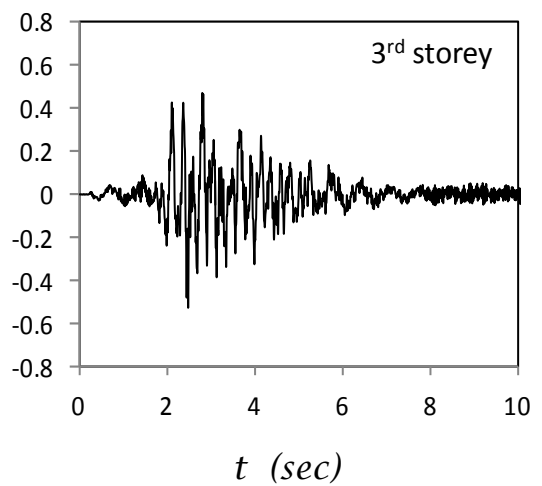
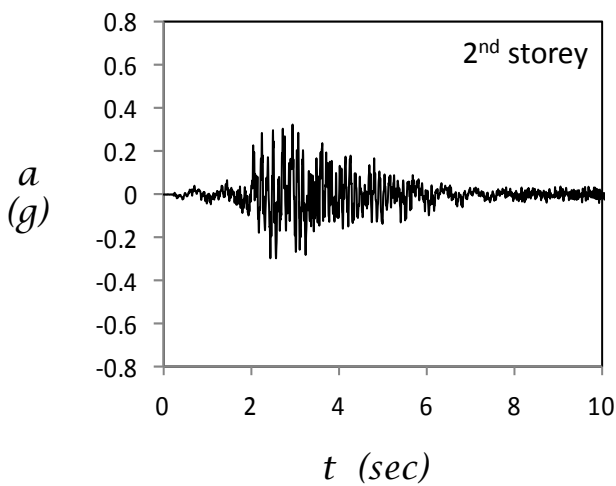
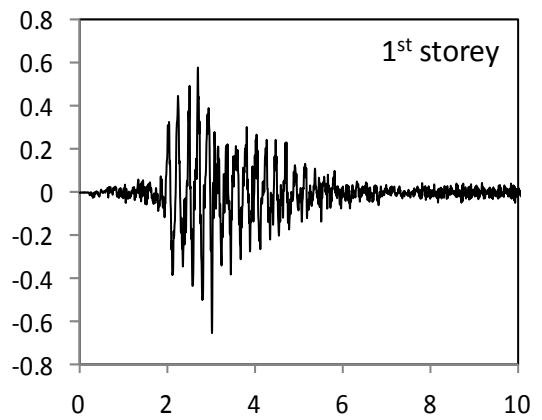
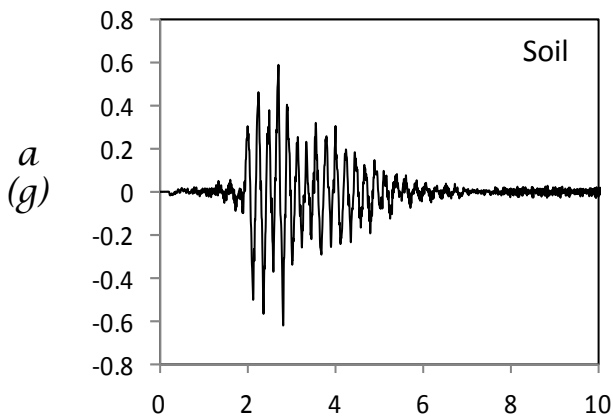
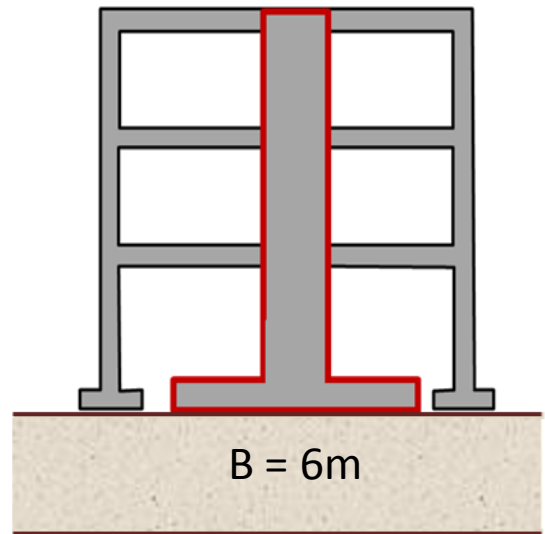
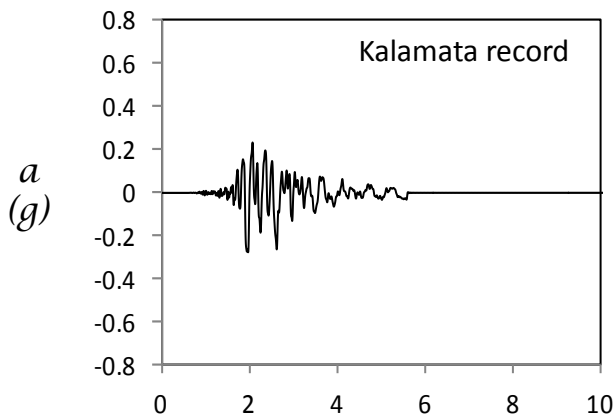

Figure B15. Acceleration time histories measured on the retrofitted building with conventional foundation ($B = 6\text{m}$) while submitted to the record of Kalamata.

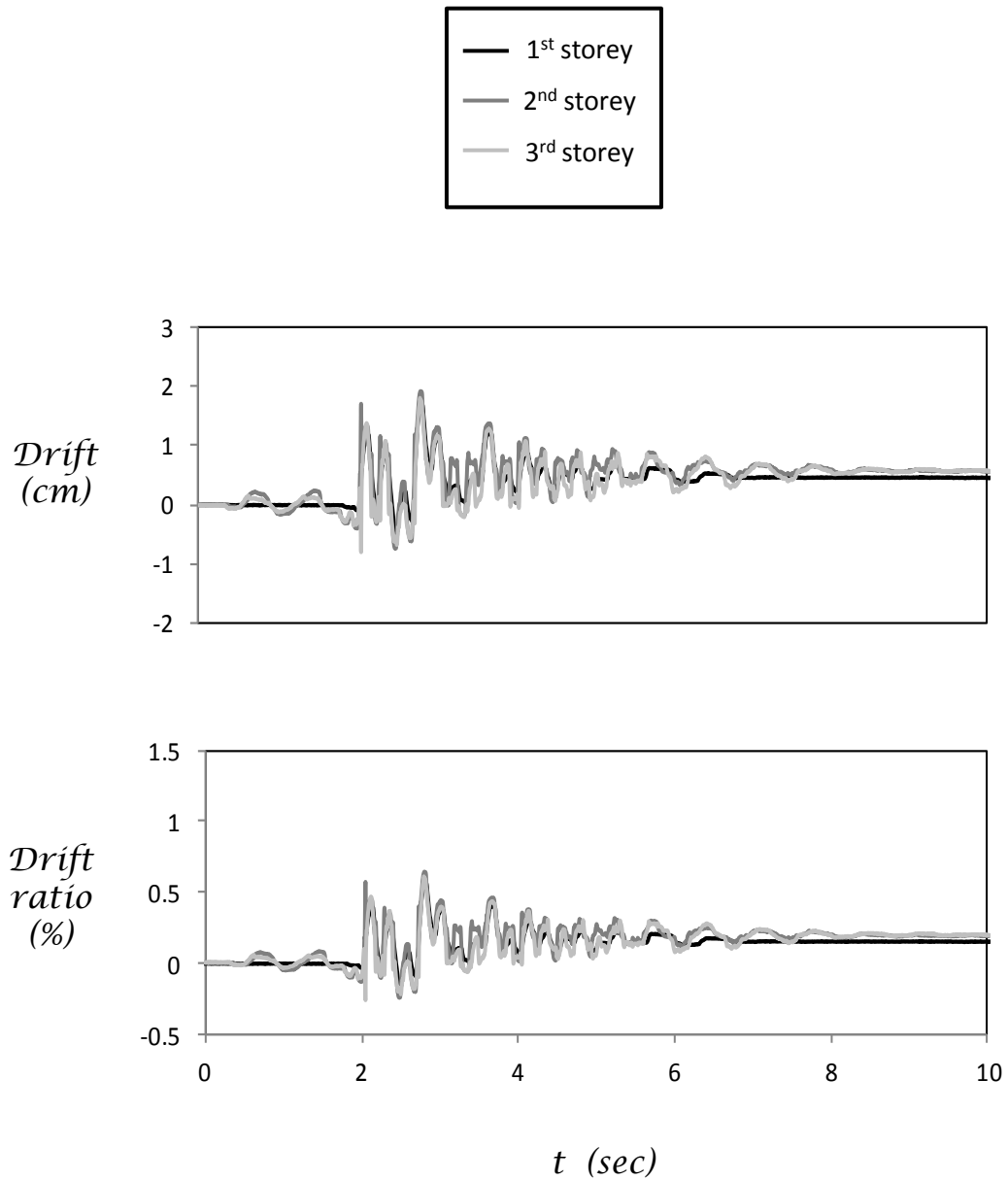
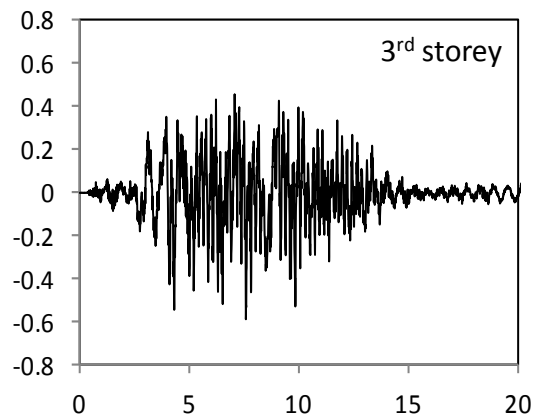
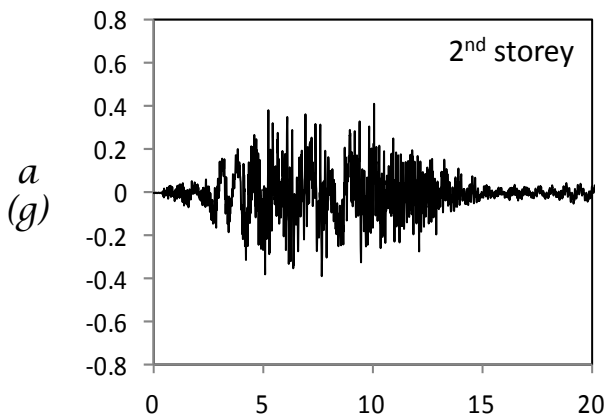
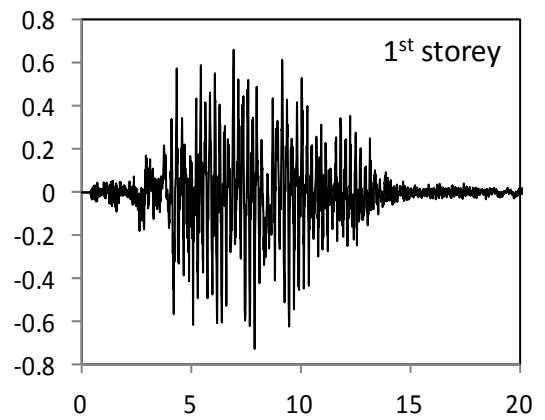
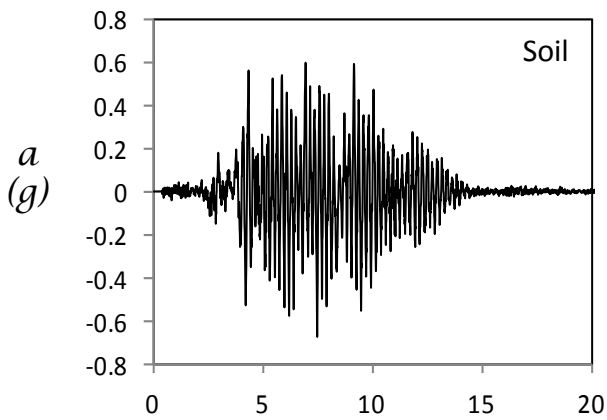
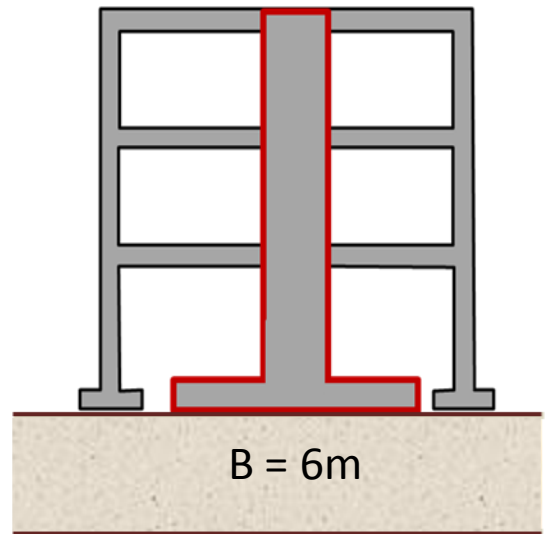
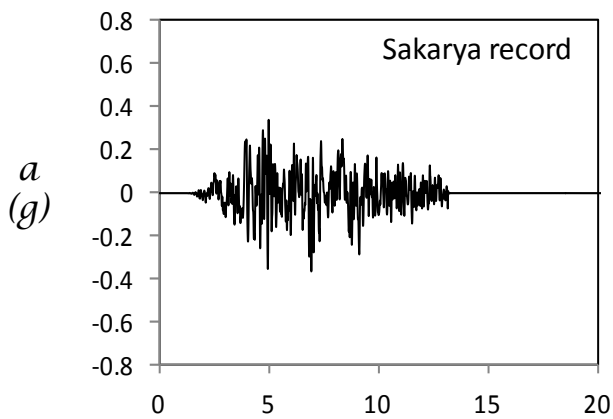

Figure B16. Time histories of storey drift and drift ratio of retrofitted building with conventional foundation ($B = 6\text{m}$) while submitted to the record of Kalamata.



t (sec)

t (sec)

Figure B17. Acceleration time histories measured on the retrofitted building with conventional foundation ($B = 6\text{m}$) while submitted to the record of Sakarya.

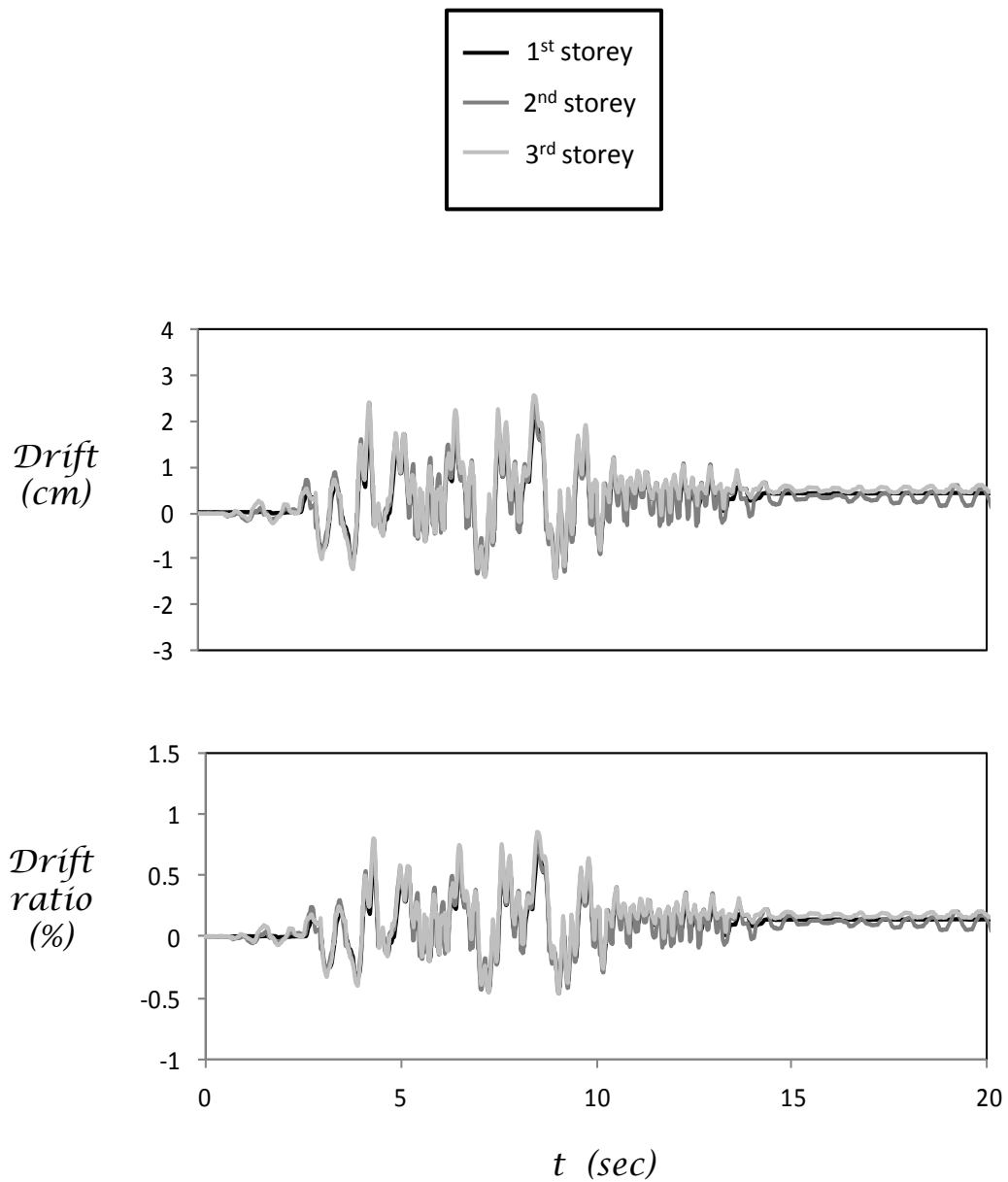
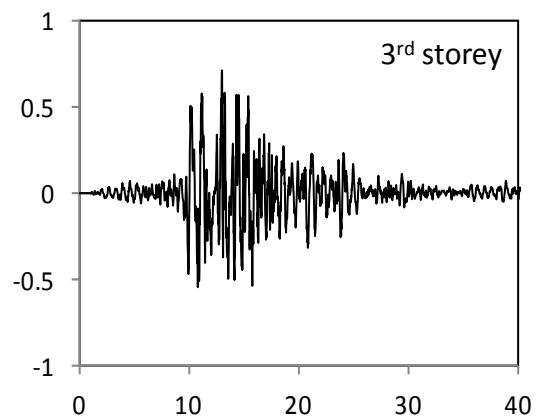
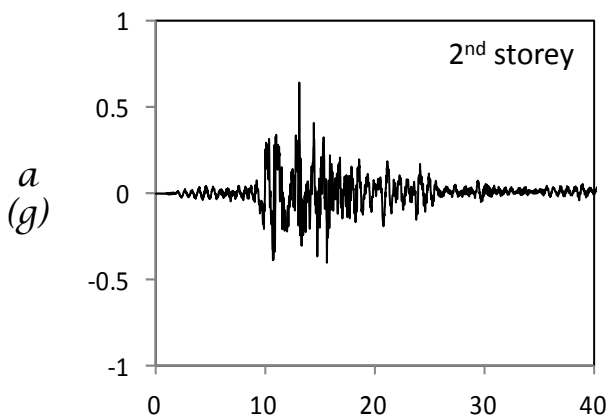
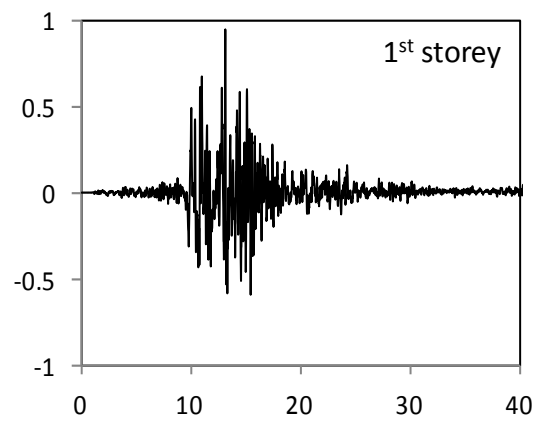
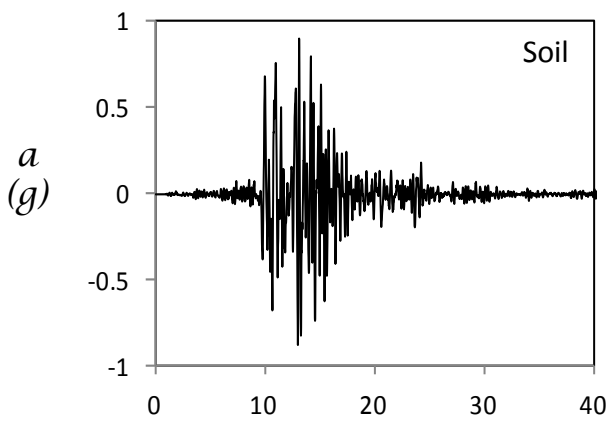
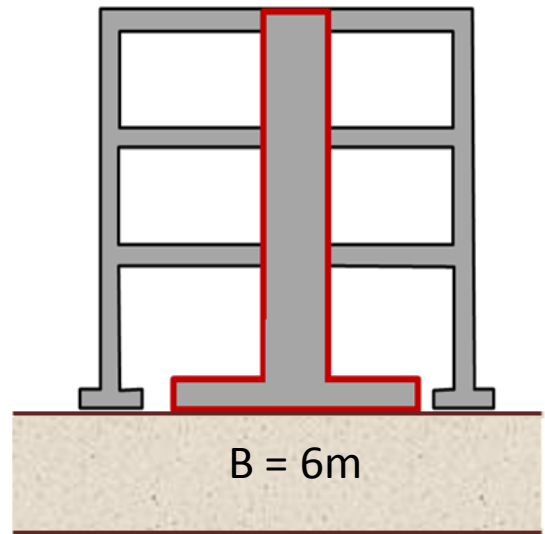
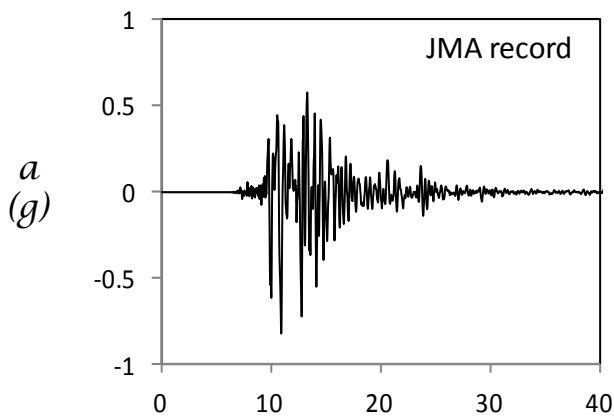

Figure B18. Time histories of storey drift and drift ratio of retrofitted building with conventional foundation ($B = 6\text{m}$) while submitted to the record of Sakarya.



t (sec)

t (sec)

Figure B19. Acceleration time histories measured on the retrofitted building with conventional foundation ($B = 6\text{m}$) while submitted to the record of JMA.

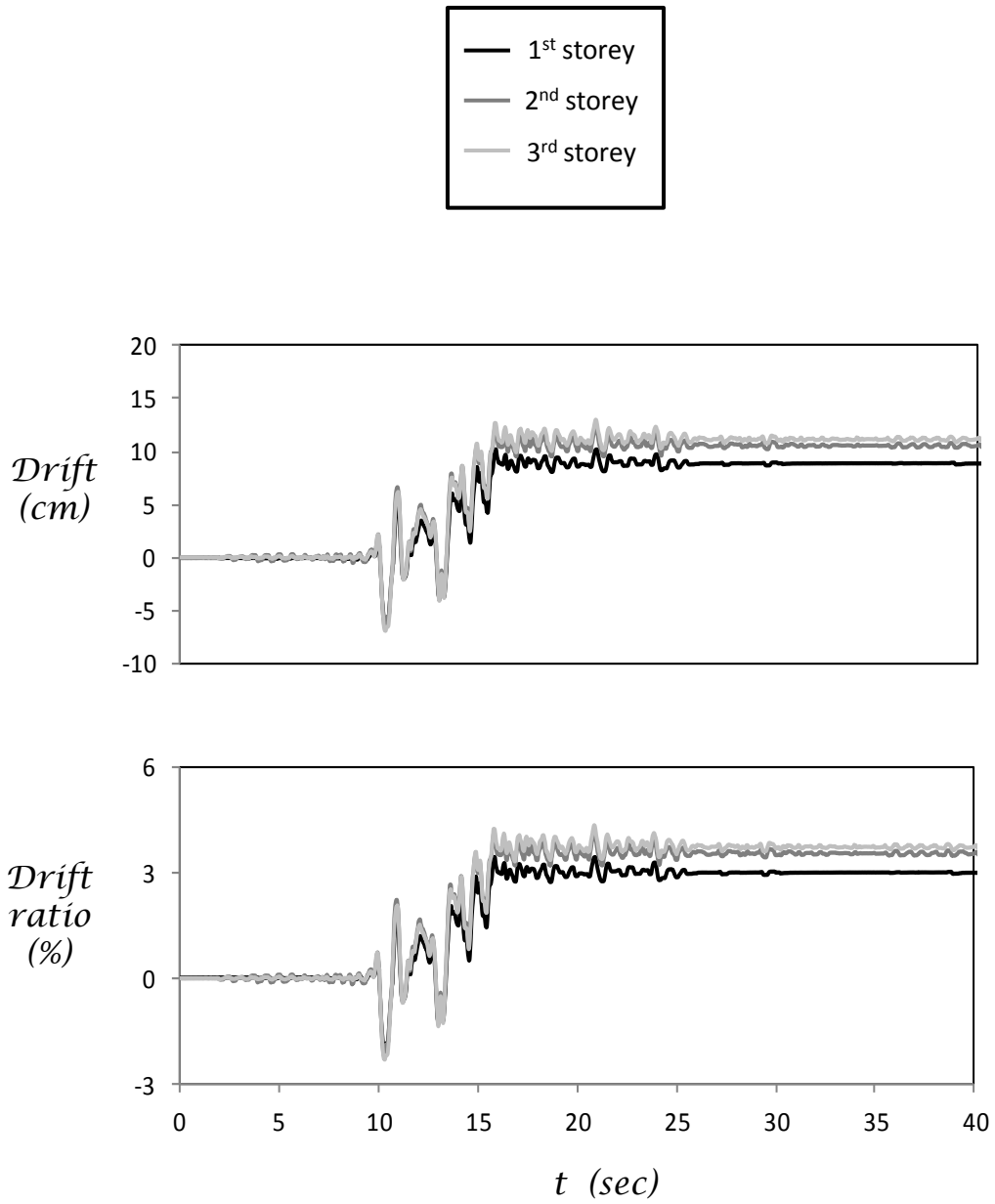

Figure B20. Time histories of storey drift and drift ratio of retrofitted building with conventional foundation ($B = 6\text{m}$) while submitted to the record of JMA.

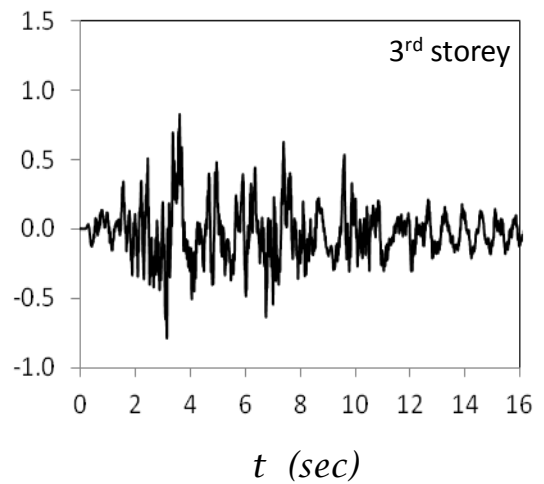
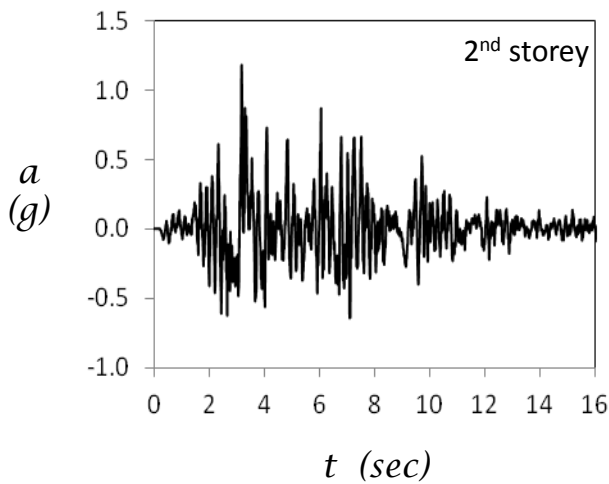
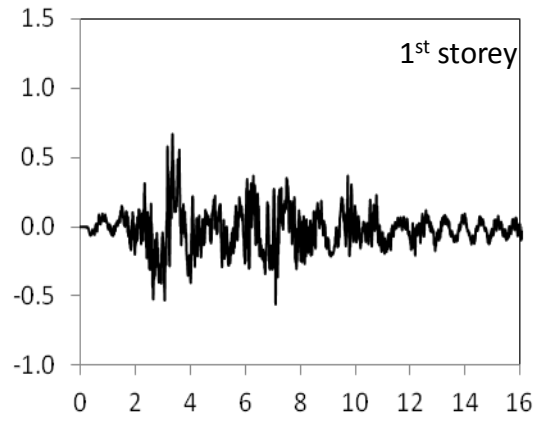
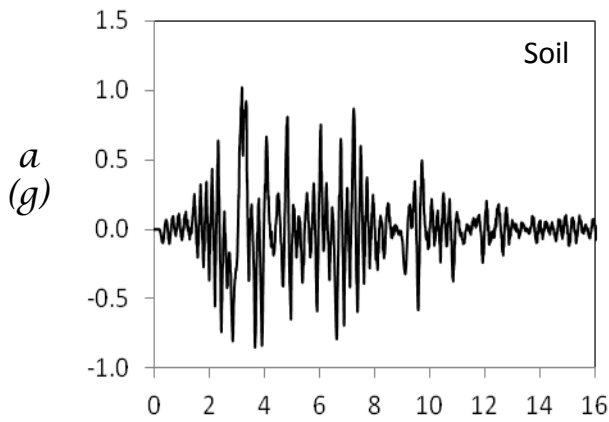
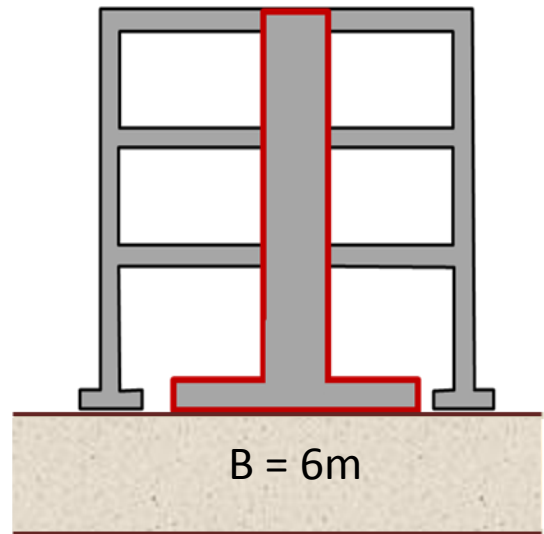
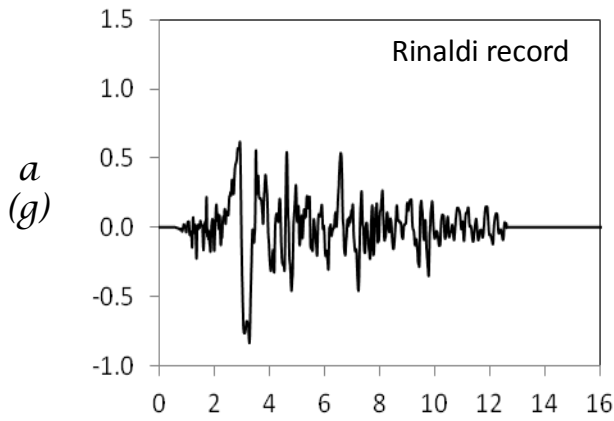

Figure B21. Acceleration time histories measured on the retrofitted building with conventional foundation ($B = 6\text{m}$) while submitted to the record of Rinaldi.

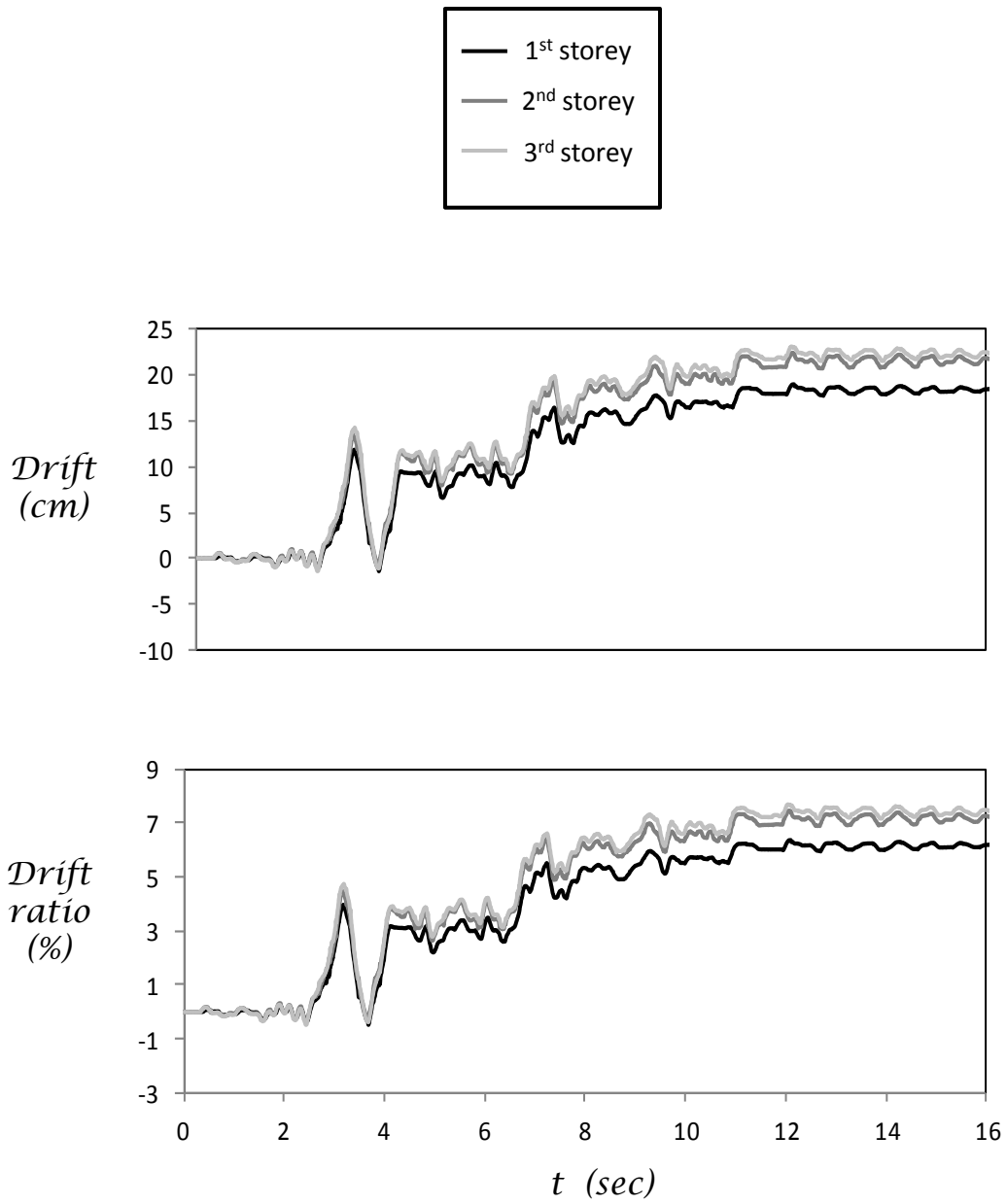

Figure B22. Time histories of storey drift and drift ratio of retrofitted building with conventional foundation ($B = 6\text{m}$) while submitted to the record of Rinaldi.

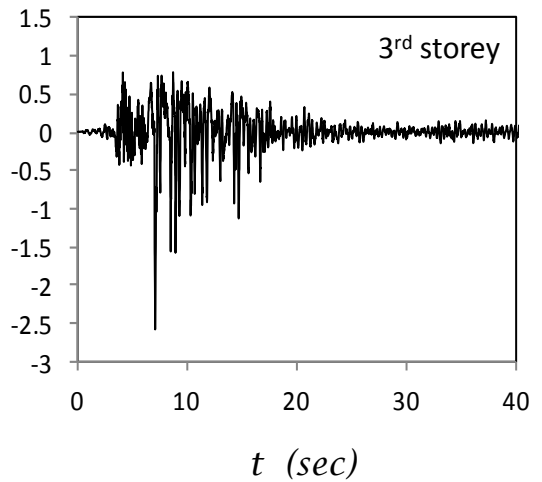
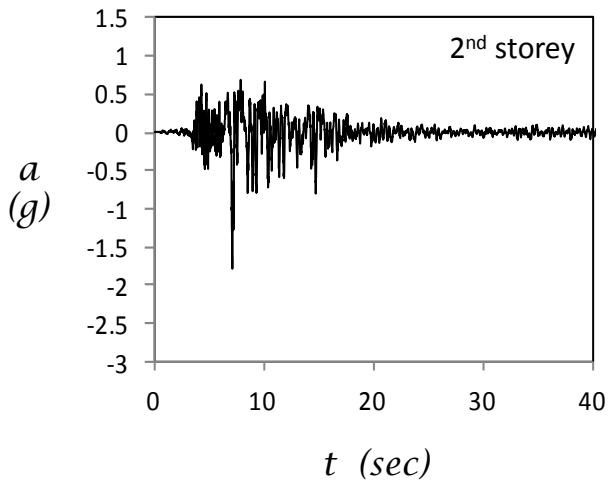
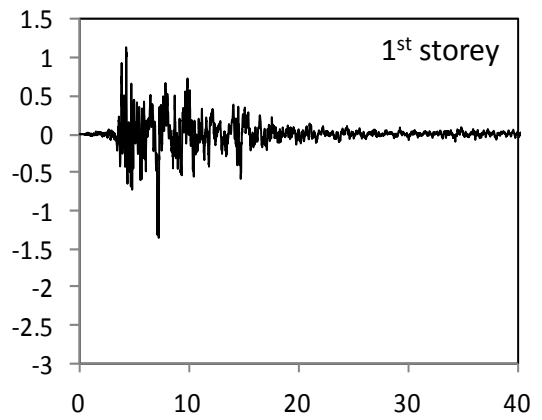
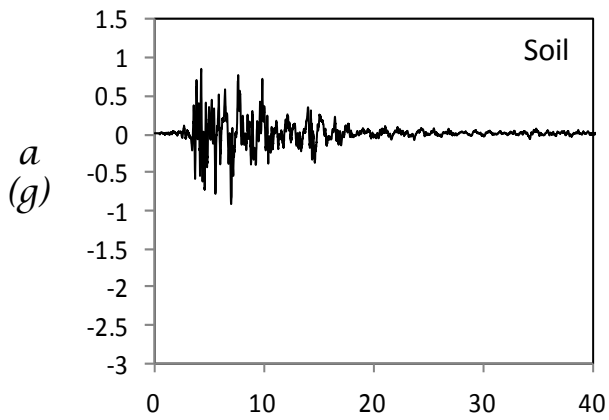
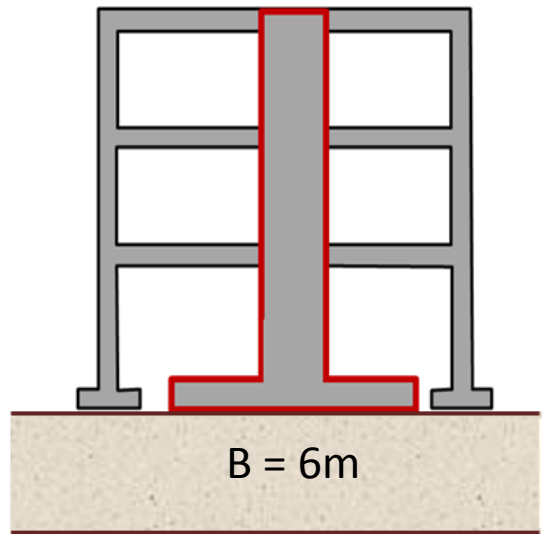
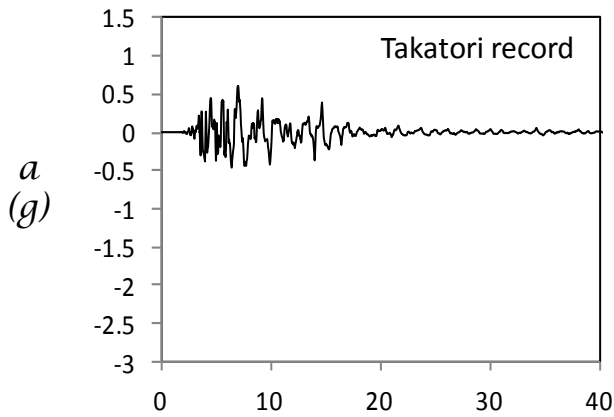

Figure B23. Acceleration time histories measured on the retrofitted building with conventional foundation ($B = 6\text{m}$) while submitted to the record of Takatori.

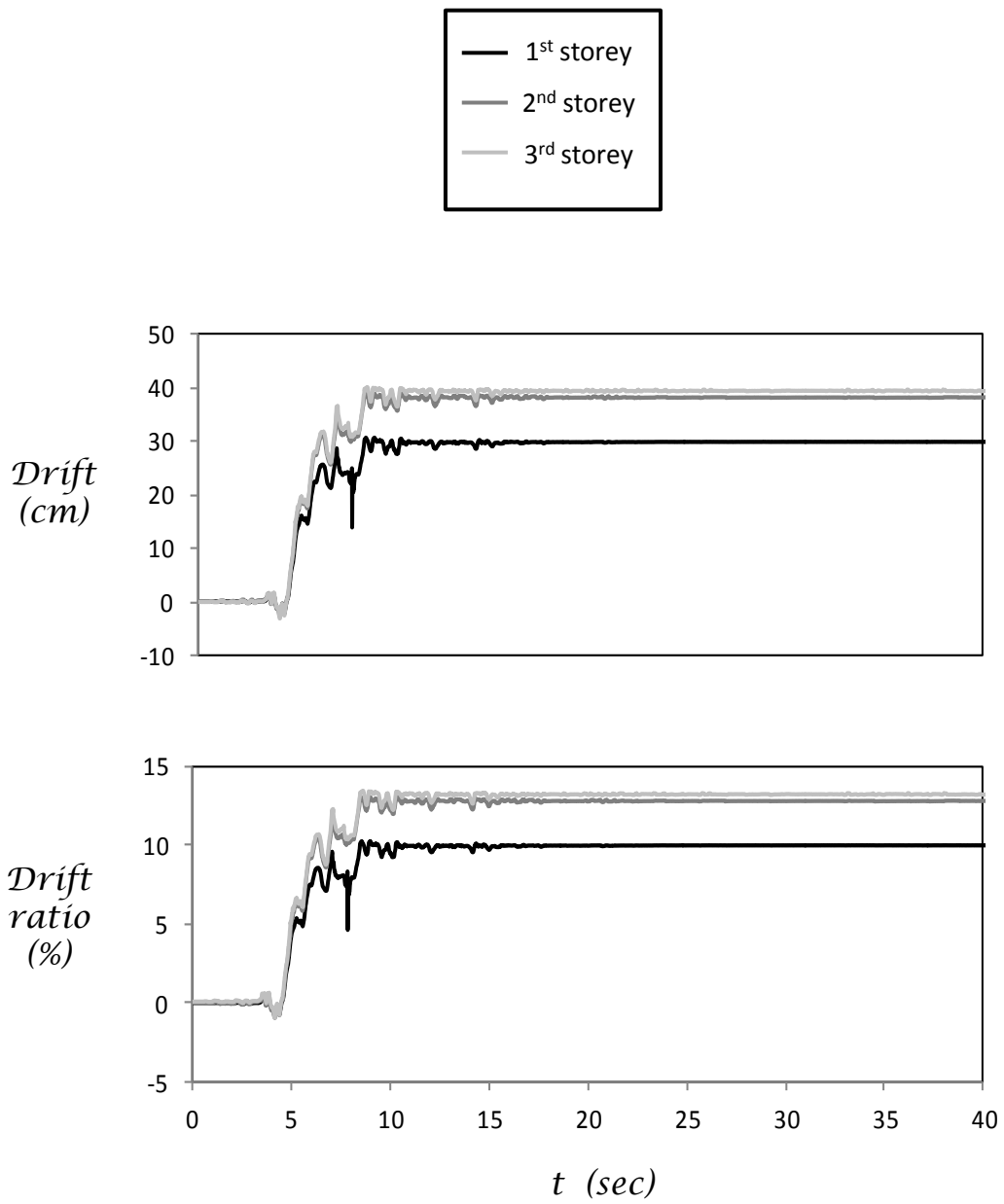

Figure B24. Time histories of storey drift and drift ratio of retrofitted building with conventional foundation ($B = 6\text{m}$) while submitted to the record of Takatori.

Retrofitted Building:

Rocking Isolation

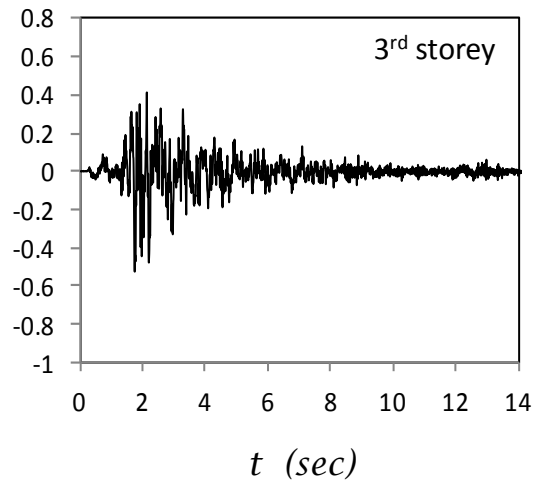
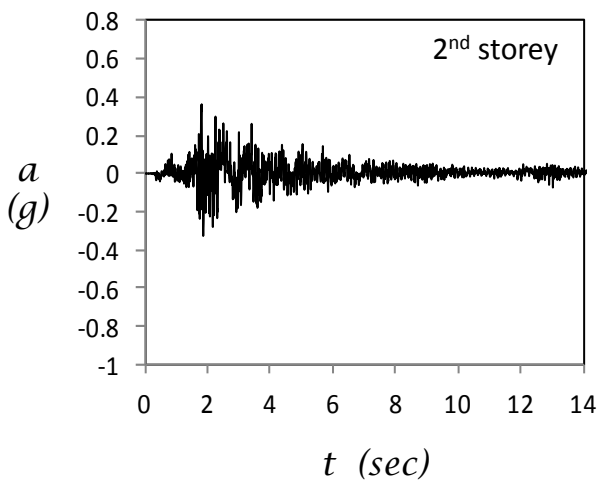
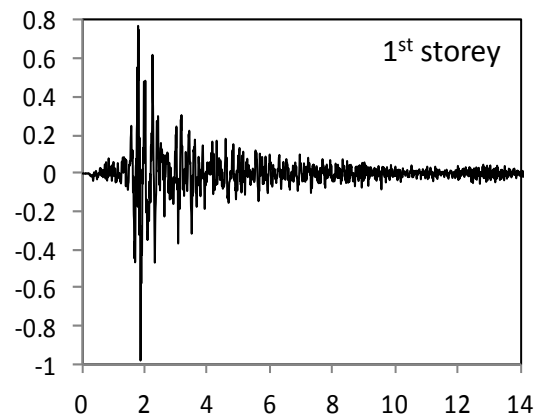
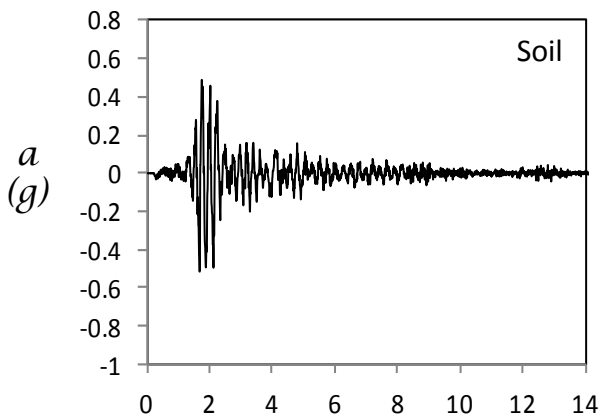
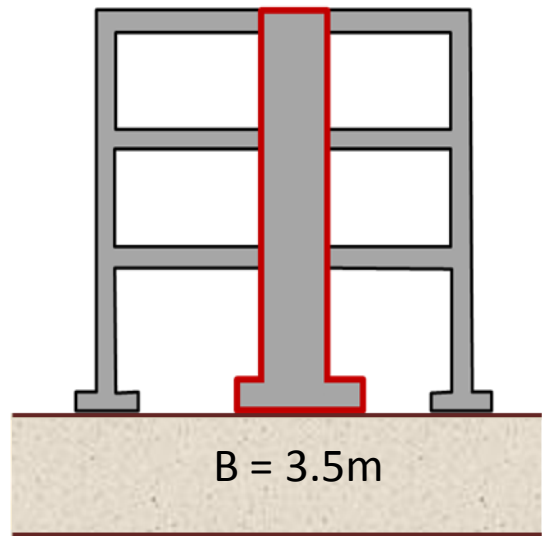
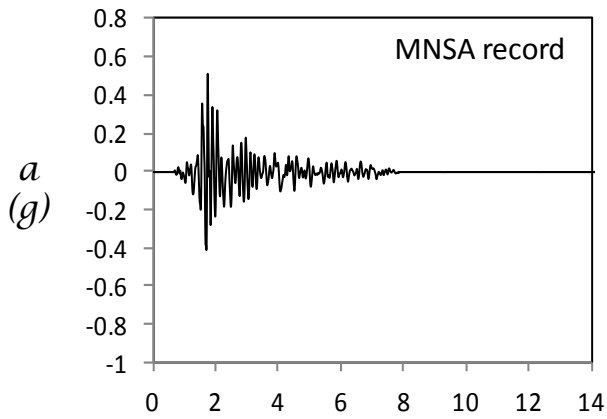

Figure B25. Acceleration time histories measured on the retrofitted building with rocking isolation ($B = 3.5\text{m}$) while submitted to the record of MNSA.

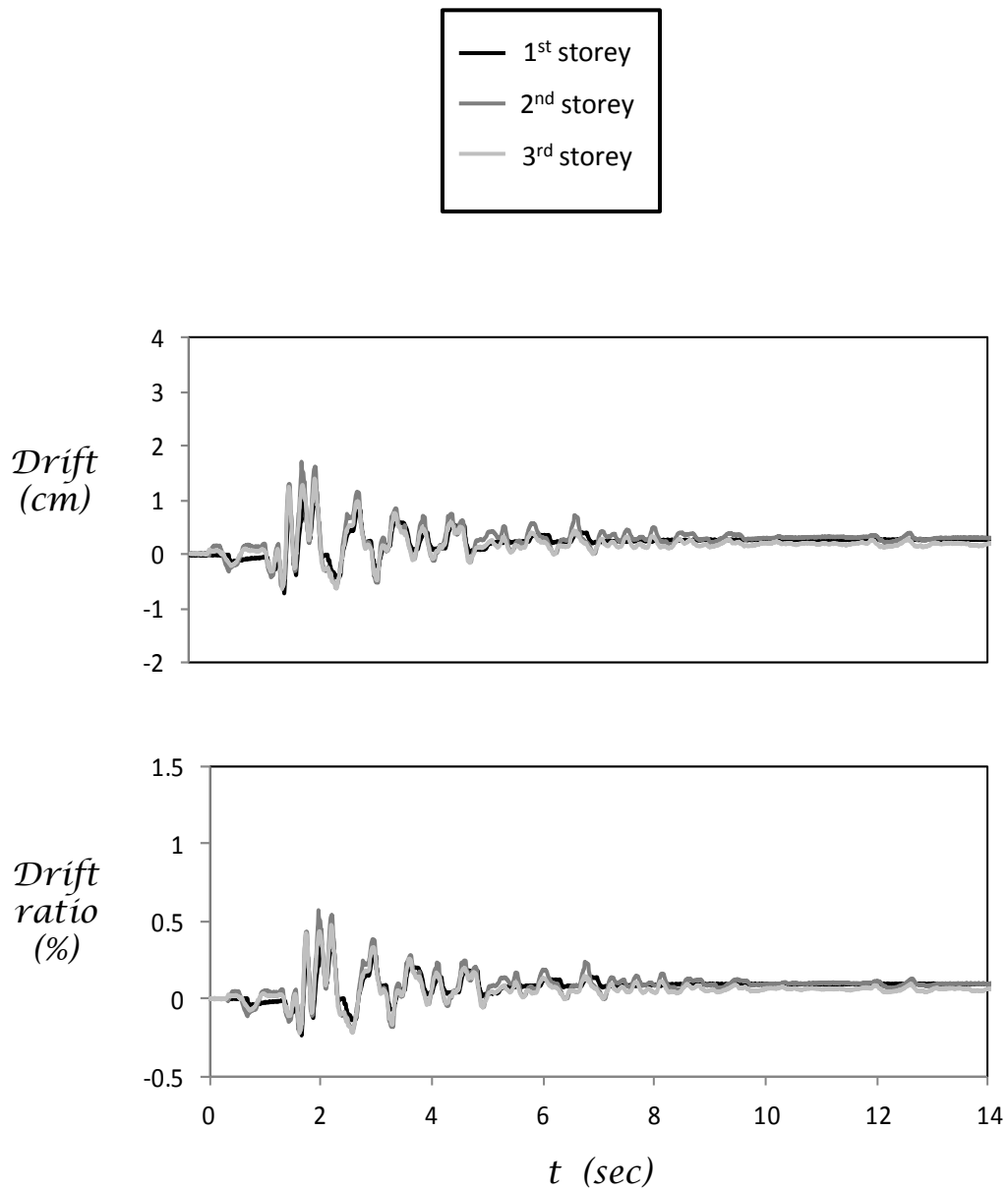
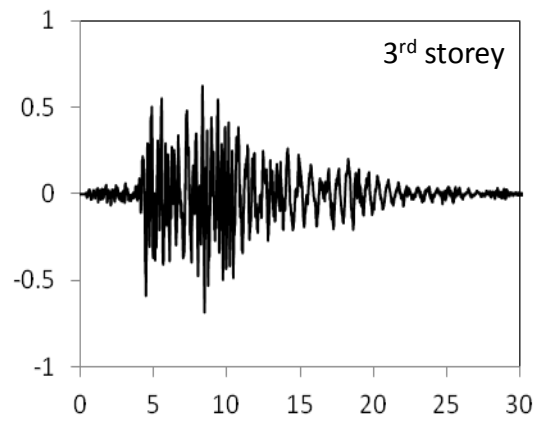
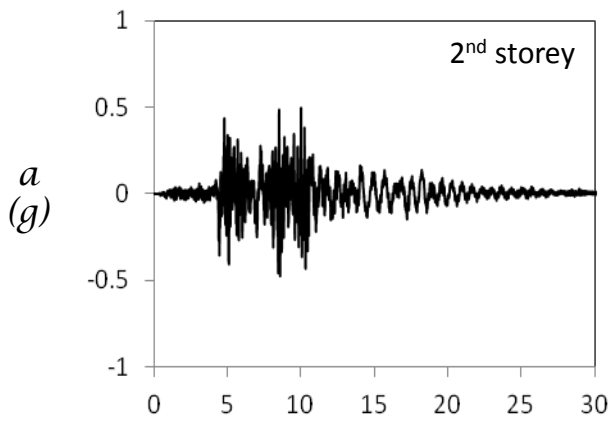
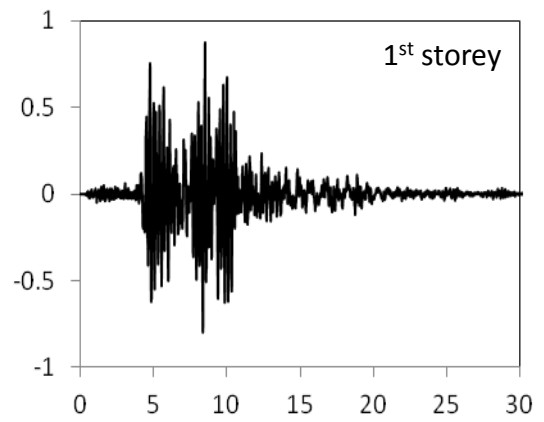
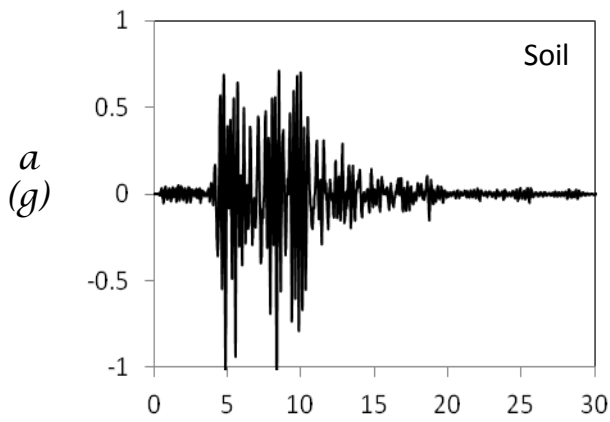
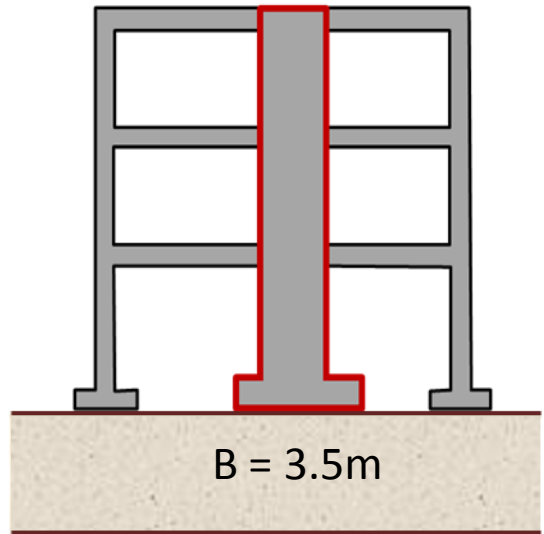
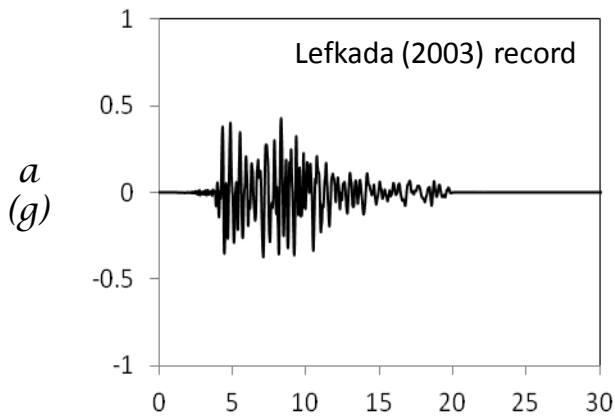

Figure B26. Time histories of storey drift and drift ratio of retrofitted building with rocking isolation ($B = 3.5\text{m}$) while submitted to the record of MNSA.



t (sec)

t (sec)

Figure B27. Acceleration time histories measured on the retrofitted building with rocking isolation (B = 3.5m) while submitted to the record of Lefkada (2003).

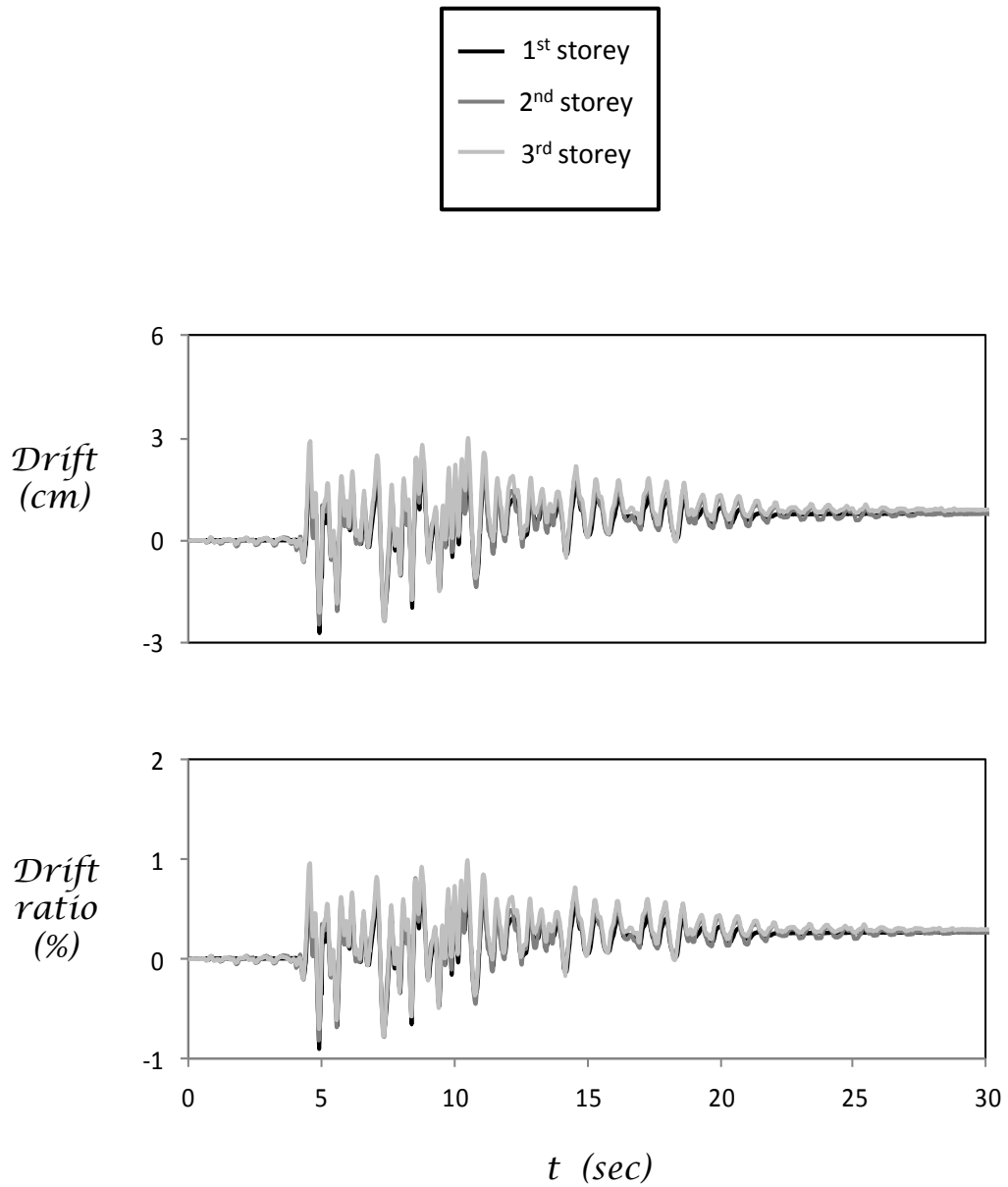
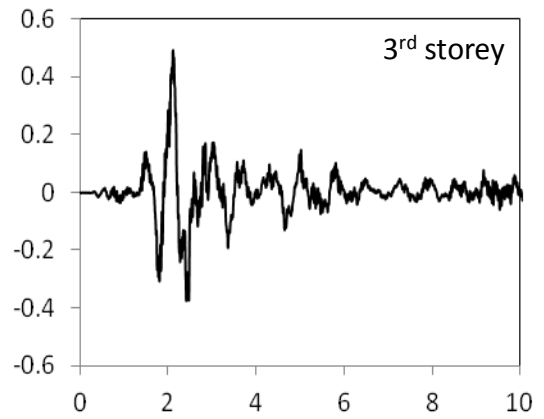
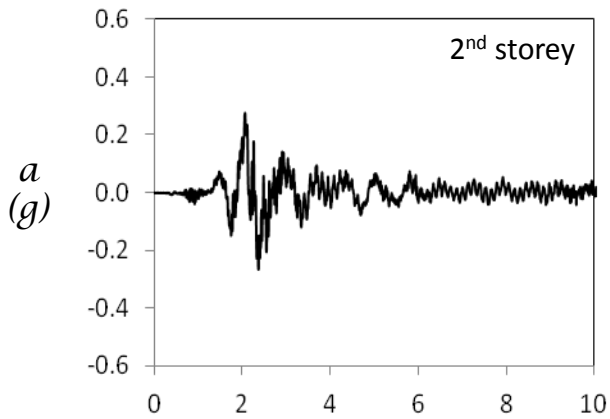
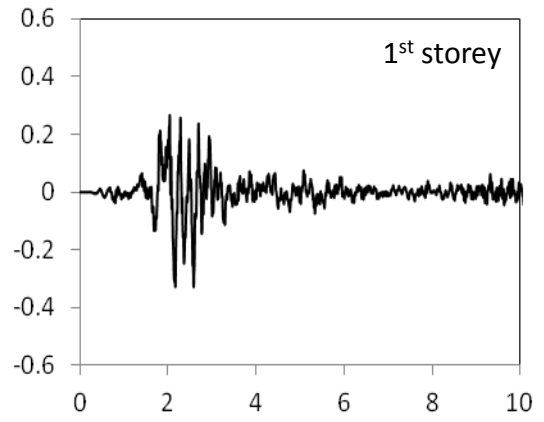
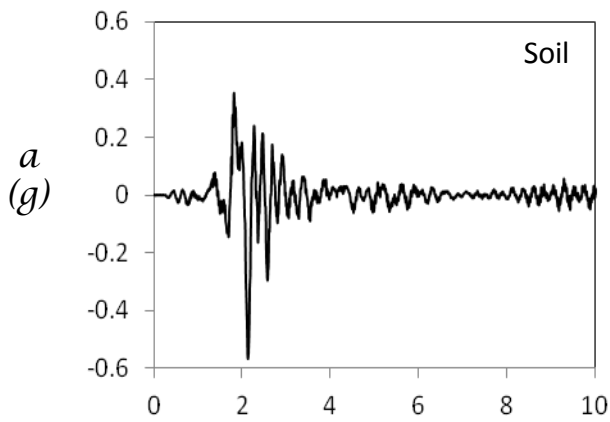
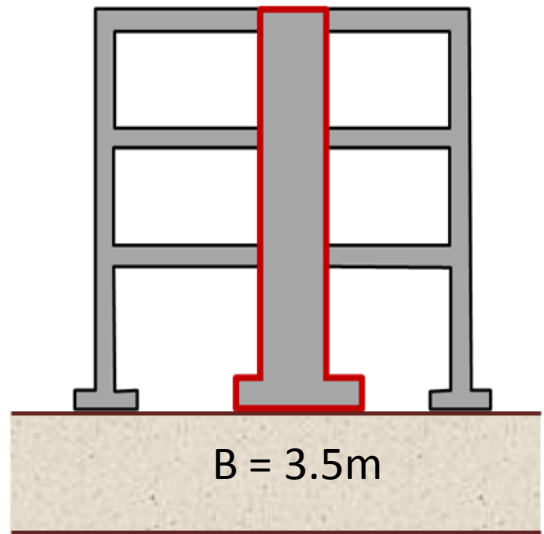
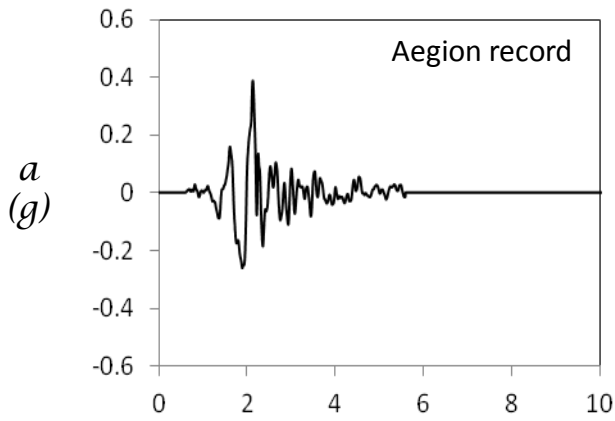

Figure B28. Time histories of storey drift and drift ratio of retrofitted building with rocking isolation ($B = 3.5\text{m}$) while submitted to the record of Lefkada (2003).



t (sec)

t (sec)

Figure B29. Acceleration time histories measured on the retrofitted building with rocking isolation ($B = 3.5\text{m}$) while submitted to the record of Aegion.

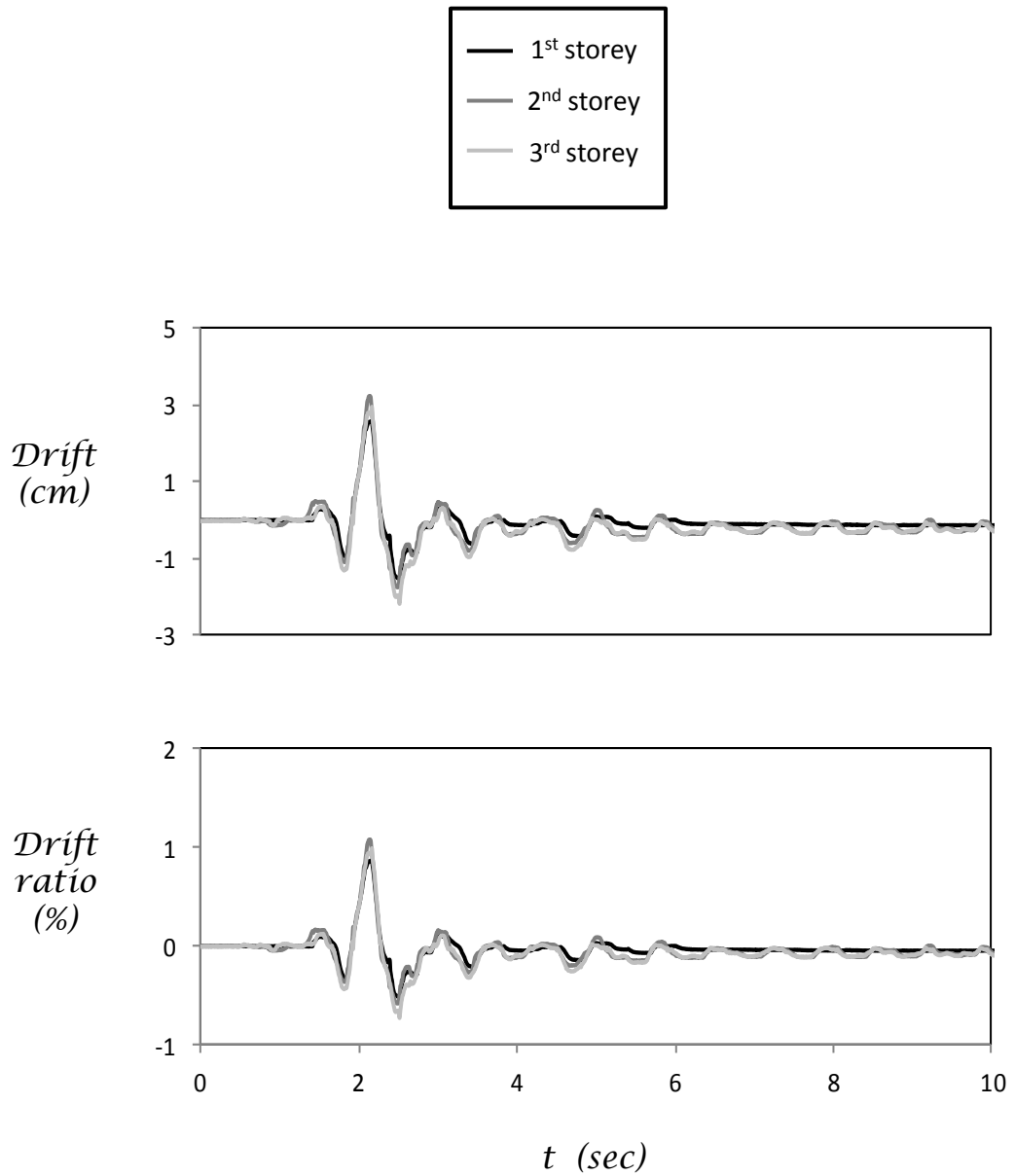

Figure B30. Time histories of storey drift and drift ratio of retrofitted building with rocking isolation ($B = 3.5\text{m}$) while submitted to the record of Aegion.

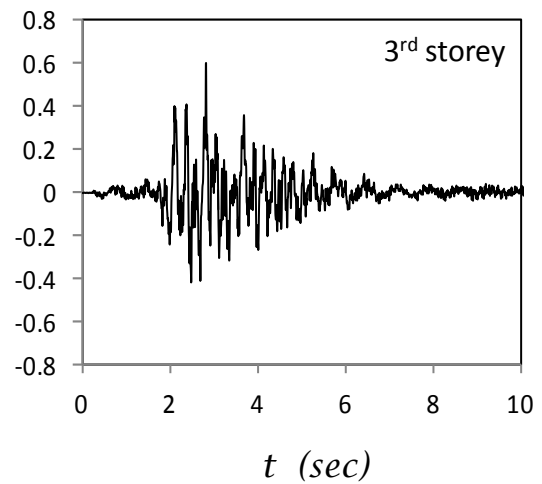
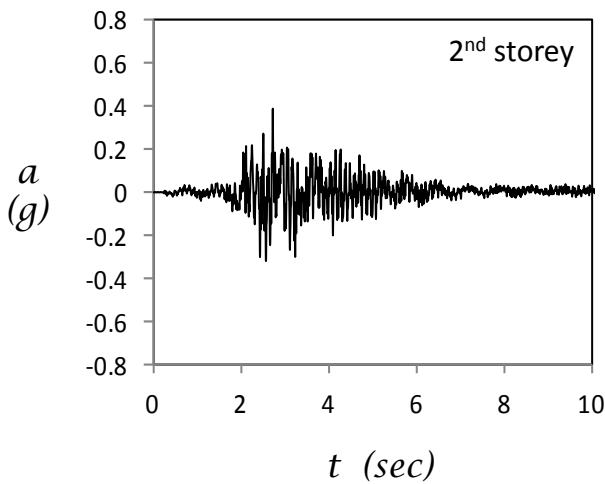
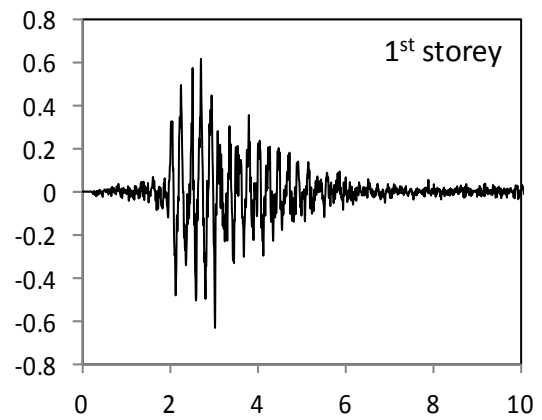
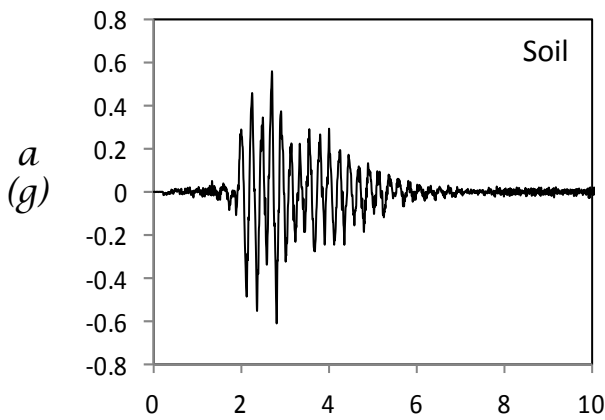
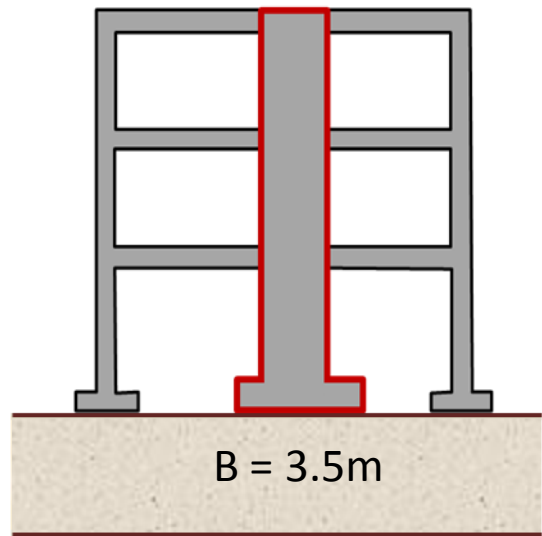
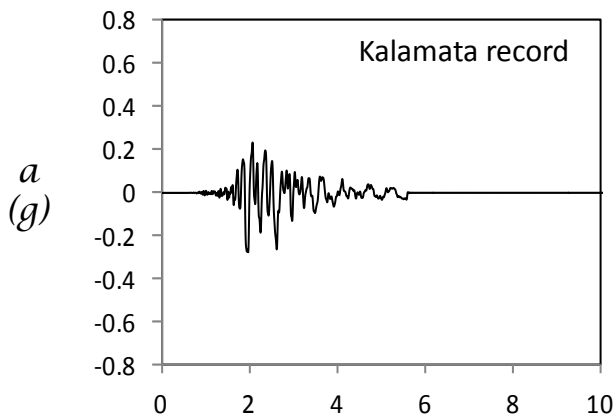

Figure B31. Acceleration time histories measured on the retrofitted building with rocking isolation ($B = 3.5\text{m}$) while submitted to the record of Kalamata.

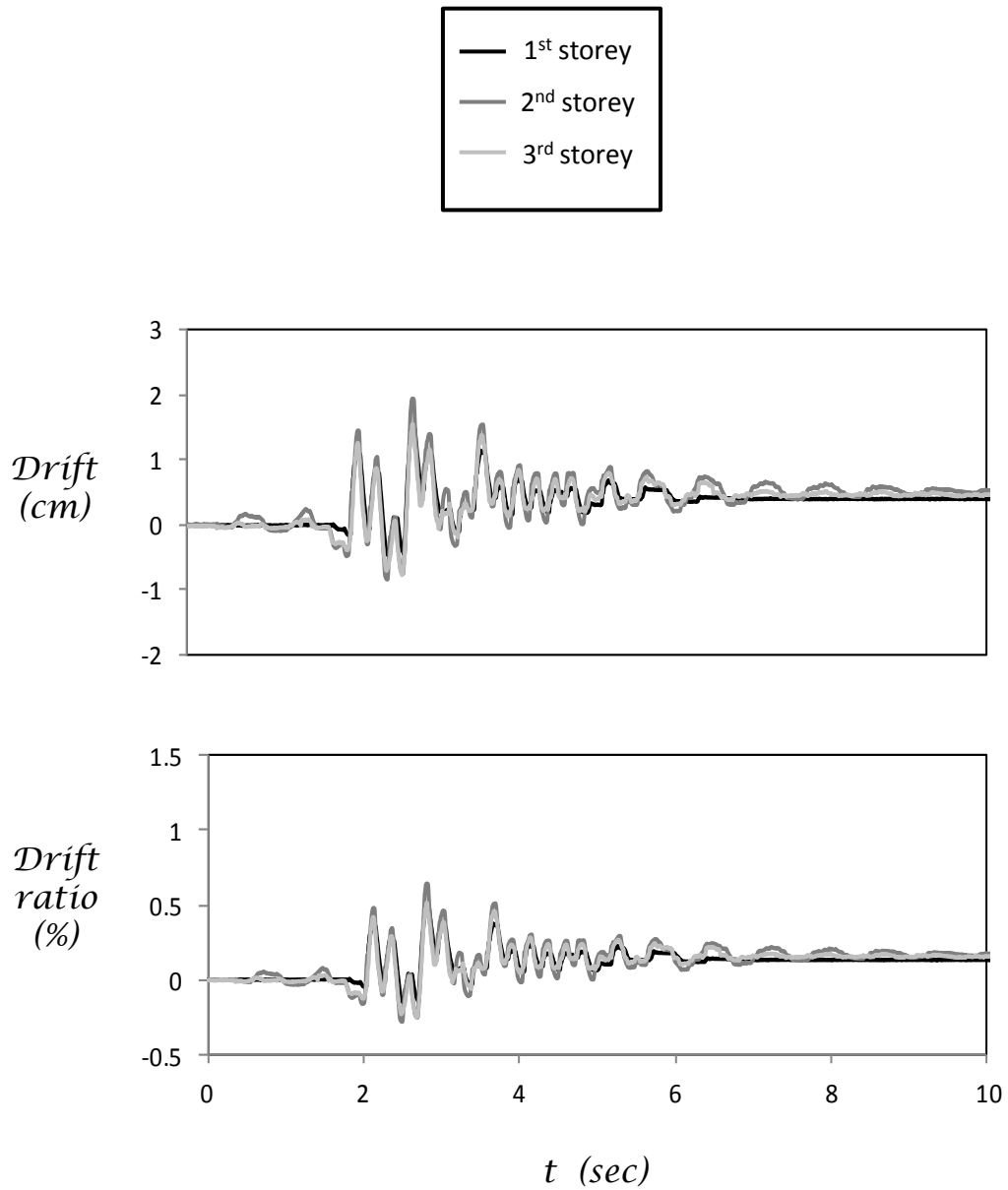

Figure B32. Time histories of storey drift and drift ratio of retrofitted building with rocking isolation ($B = 3.5\text{m}$) while submitted to the record of Kalamata.

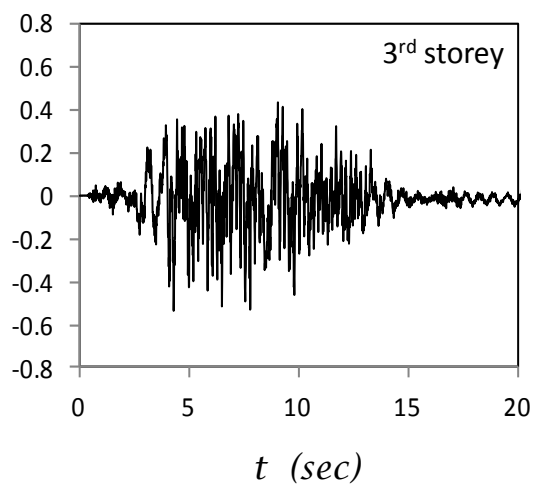
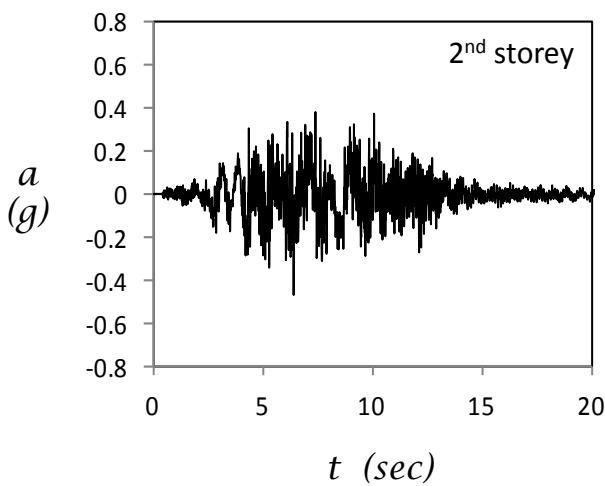
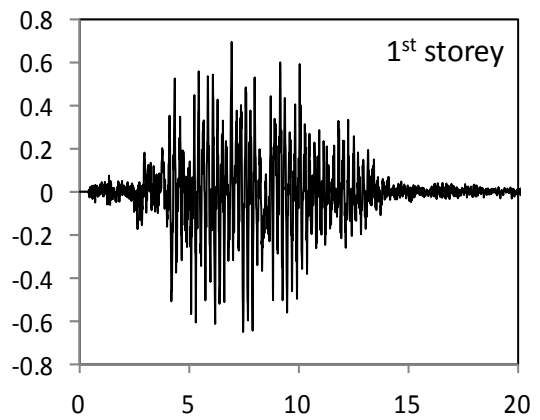
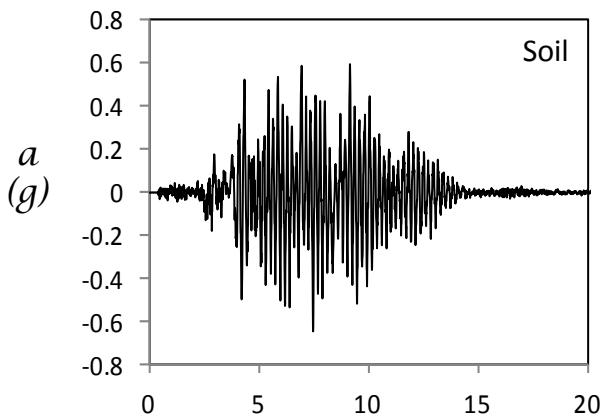
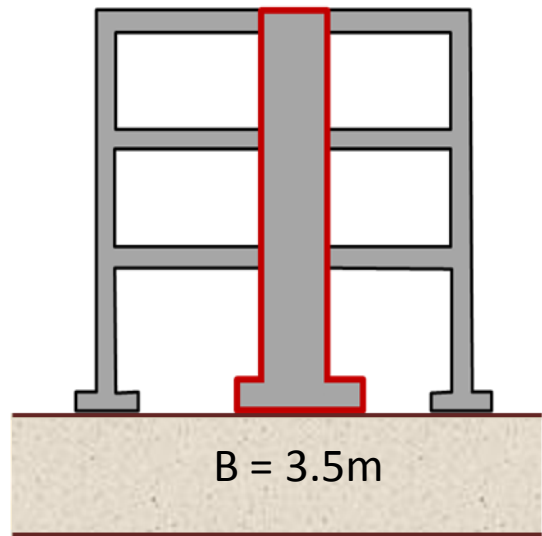
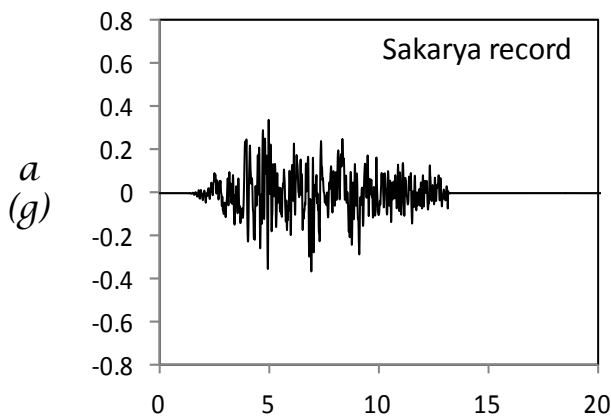

Figure B33. Acceleration time histories measured on the retrofitted building with rocking isolation ($B = 3.5\text{m}$) while submitted to the record of Sakarya.

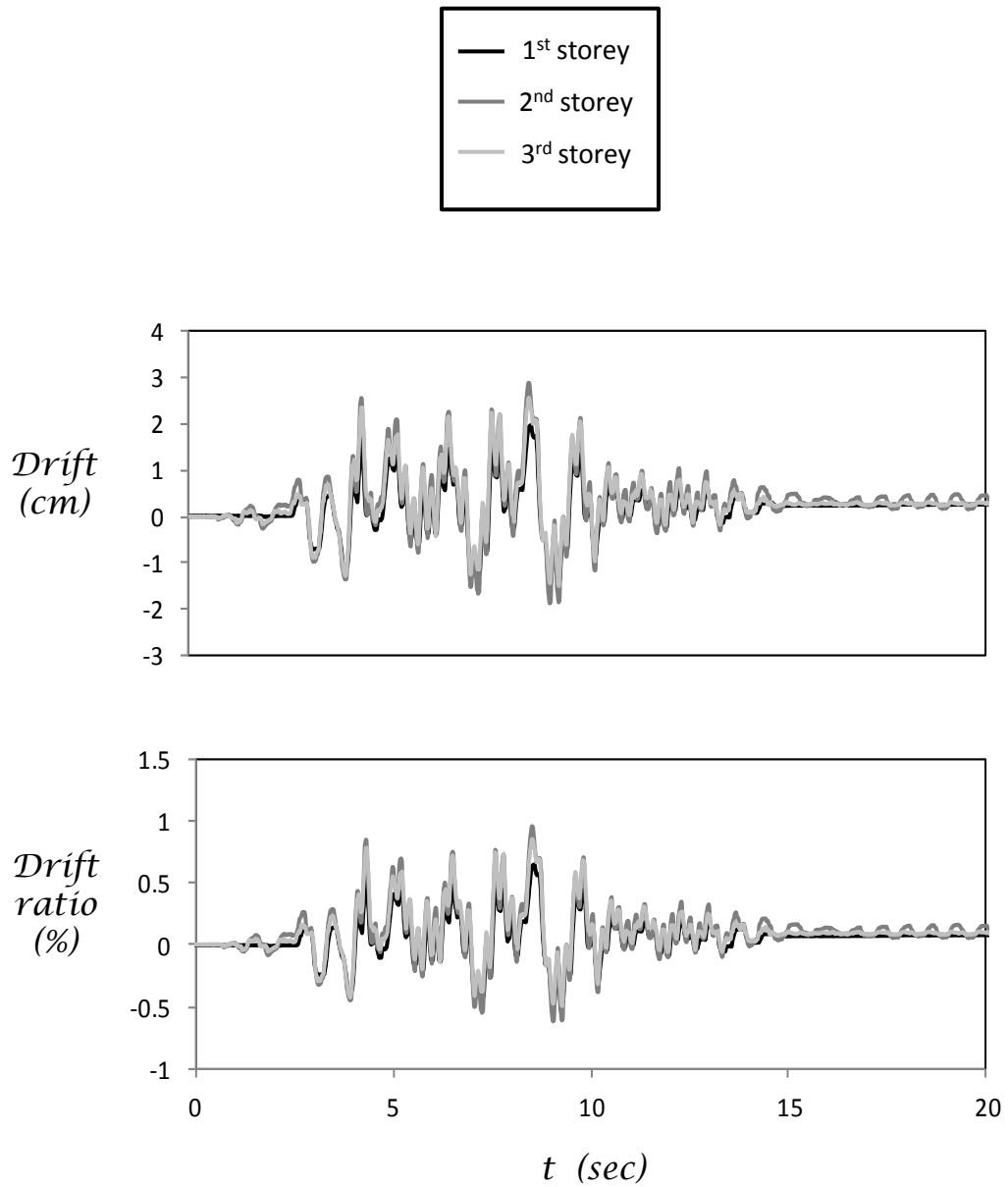
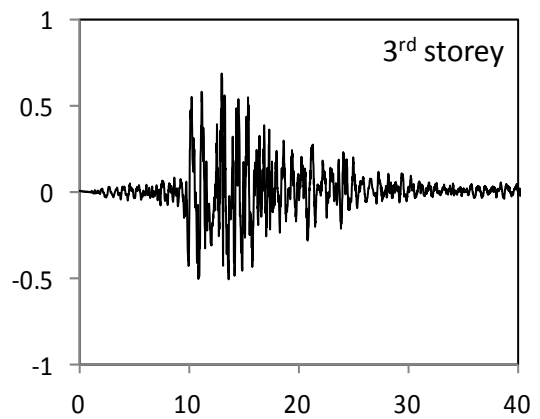
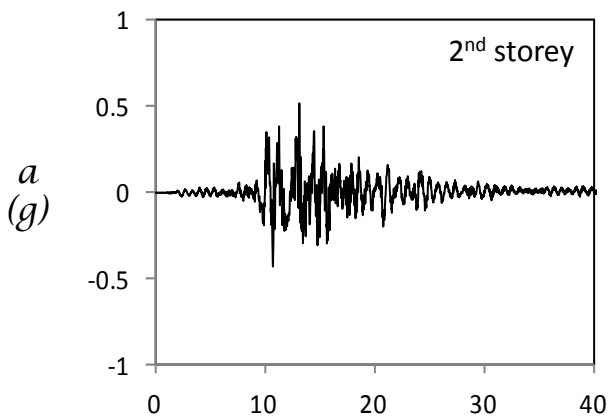
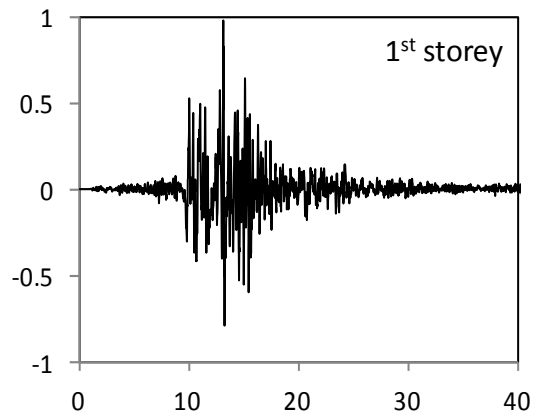
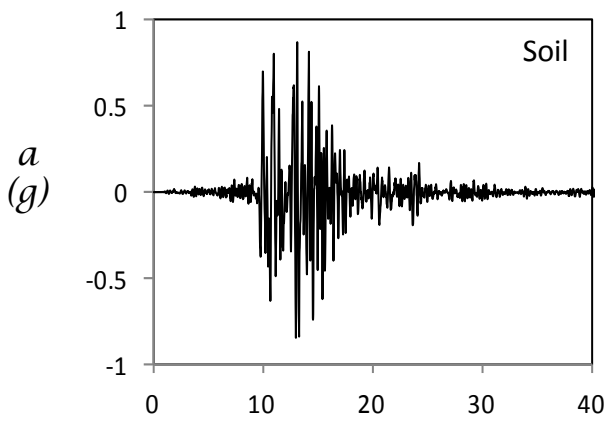
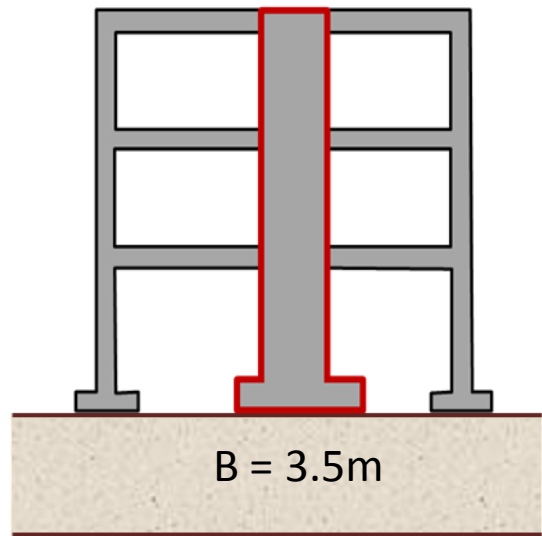
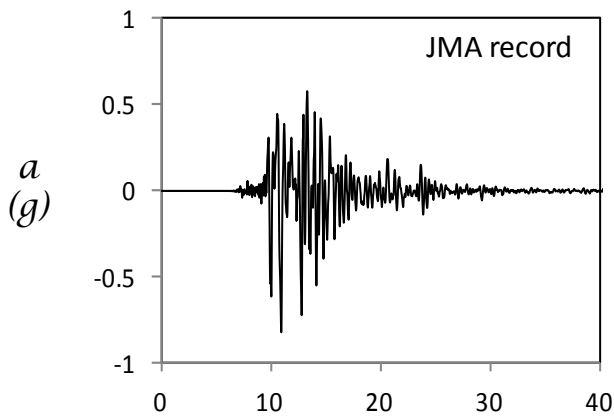

Figure B34. Time histories of storey drift and drift ratio of retrofitted building with rocking isolation ($B = 3.5\text{m}$) while submitted to the record of Sakarya.



t (sec)

t (sec)

Figure B35. Acceleration time histories measured on the retrofitted building with rocking isolation ($B = 3.5\text{m}$) while submitted to the record of JMA.

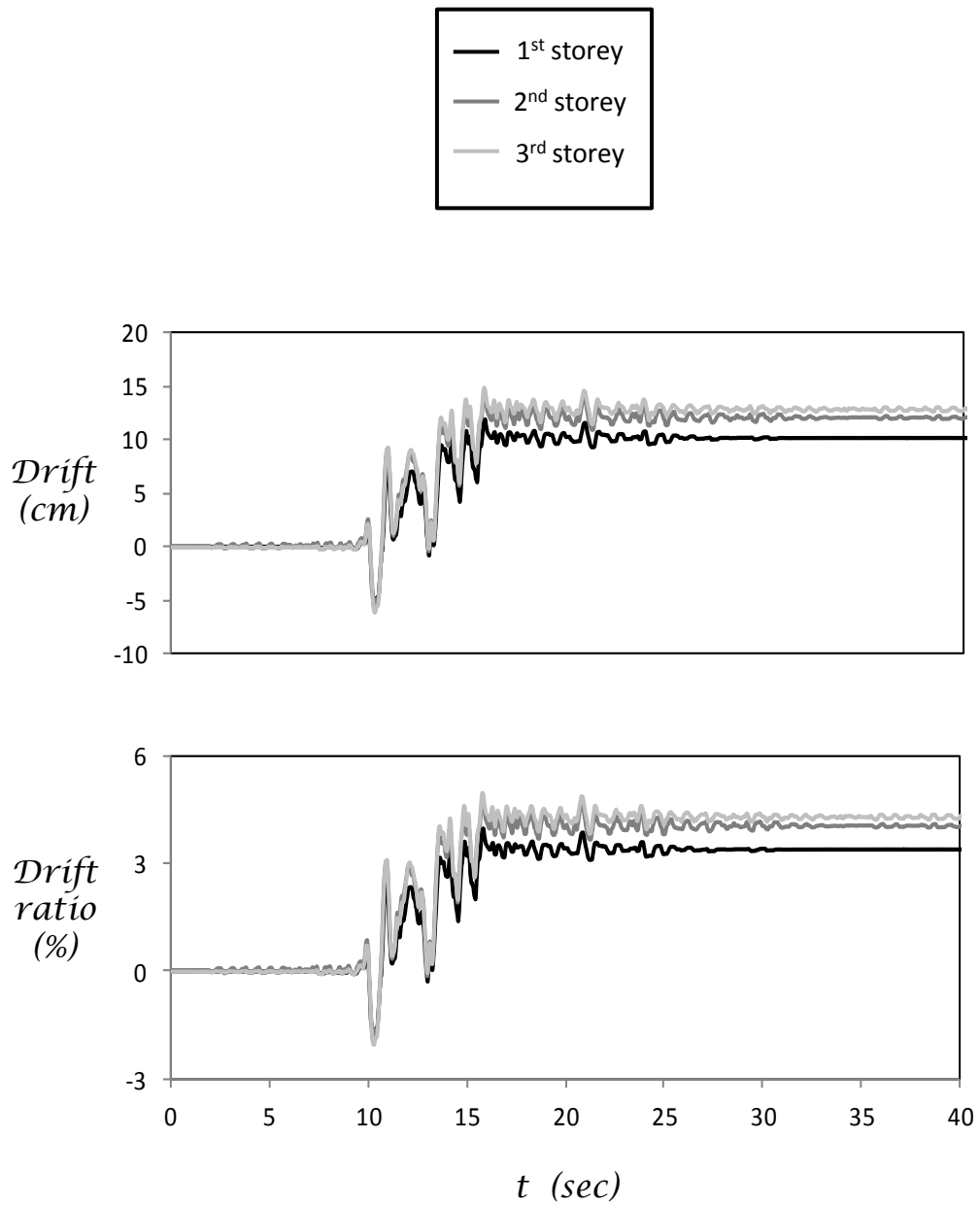
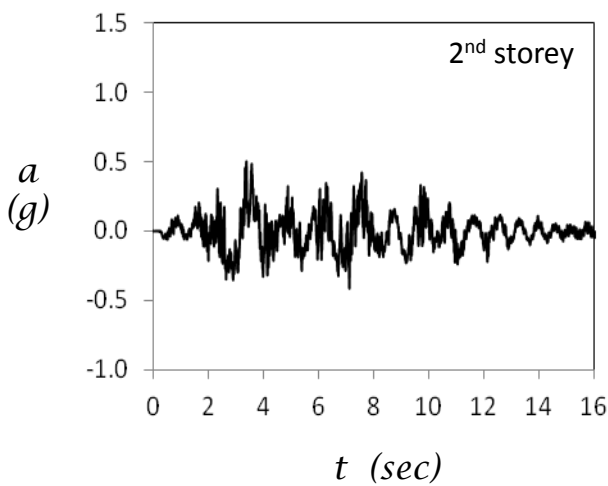
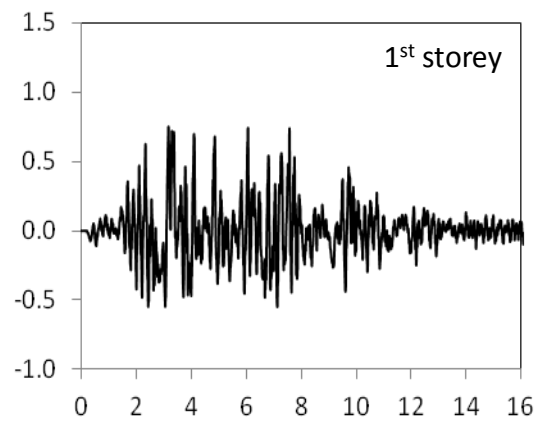
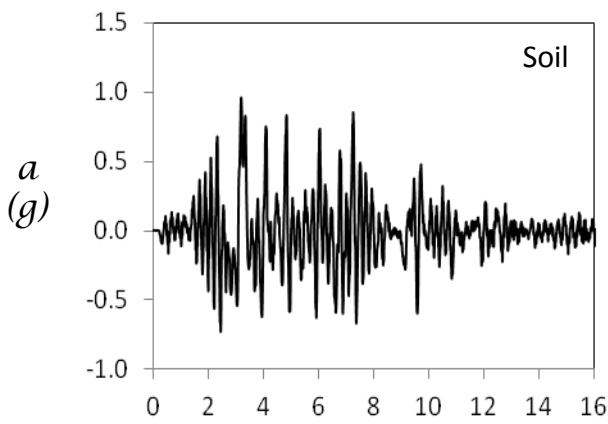
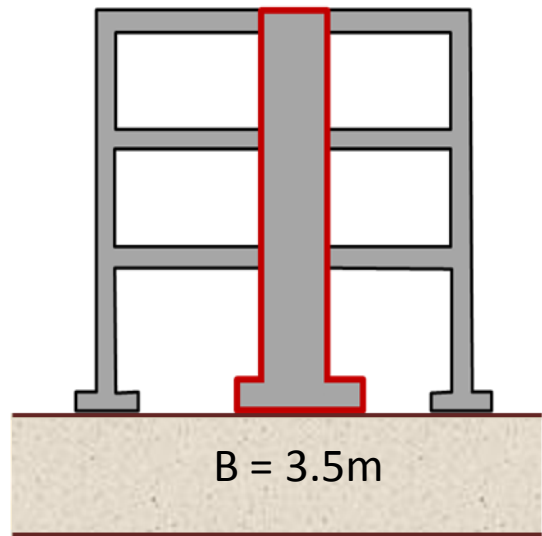
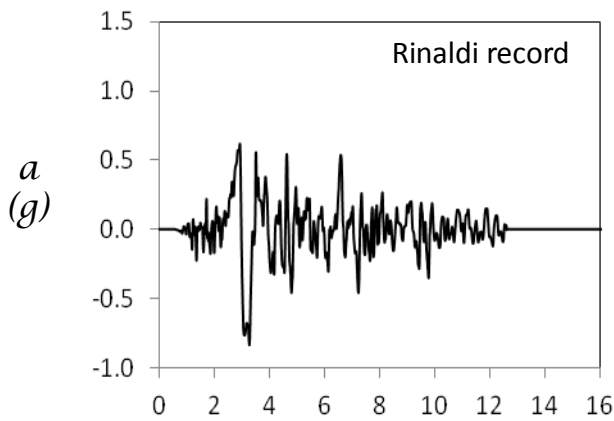

Figure B36. Time histories of storey drift and drift ratio of retrofitted building with rocking isolation ($B = 3.5\text{m}$) while submitted to the record of JMA.



t (sec)

Figure B37. Acceleration time histories measured on the retrofitted building with rocking isolation ($B = 3.5\text{m}$) while submitted to the record of Rinaldi.

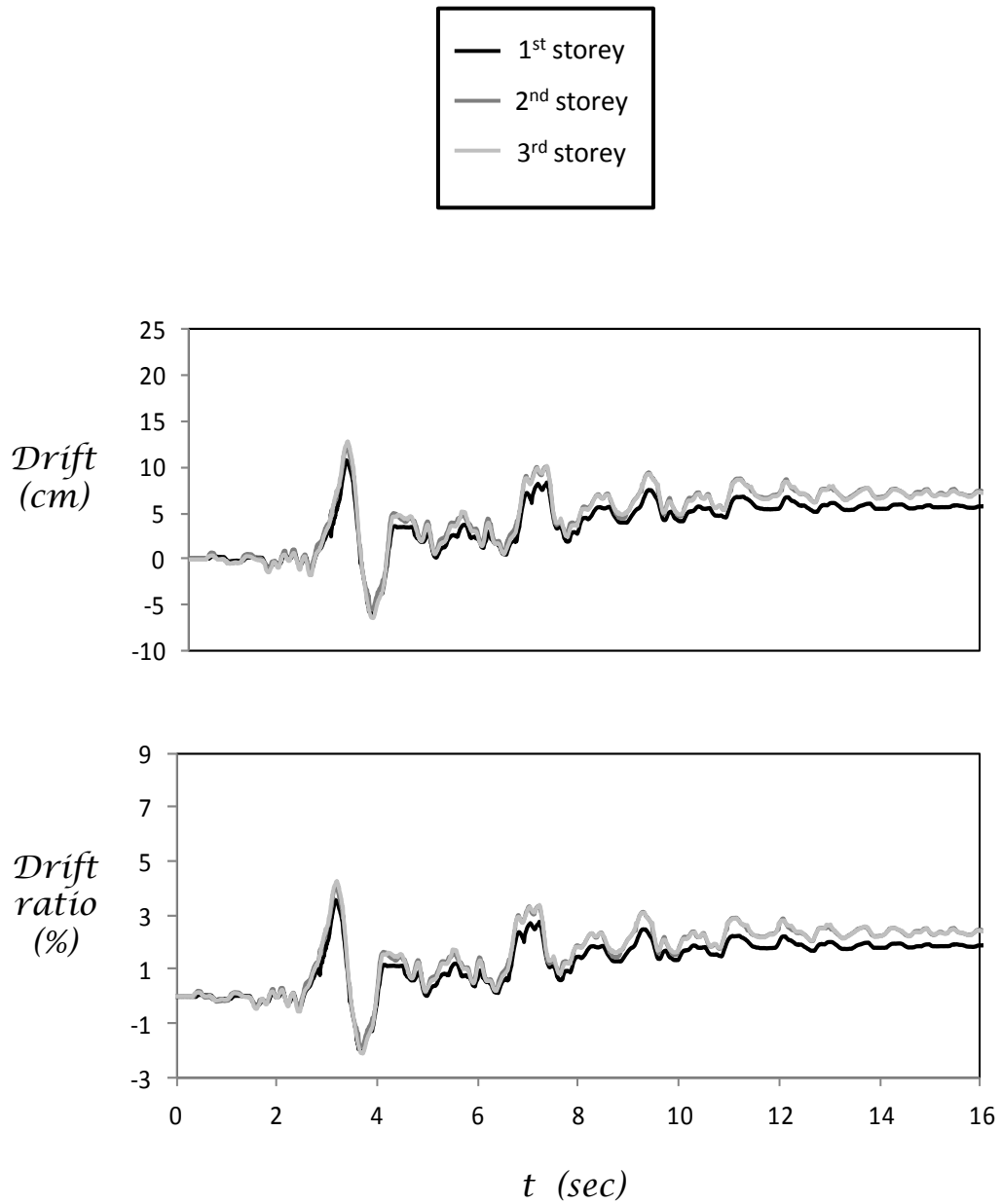
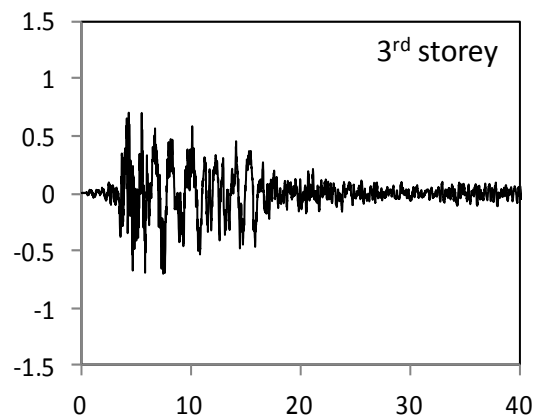
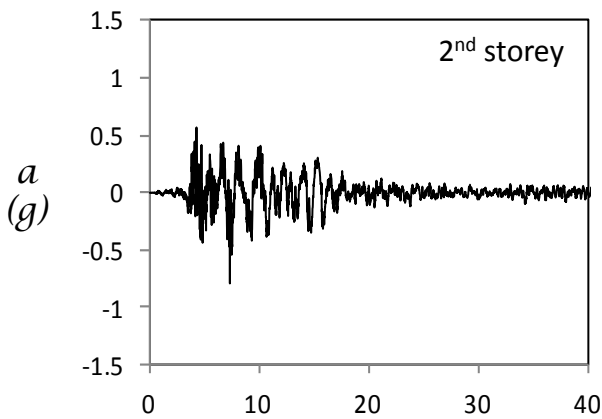
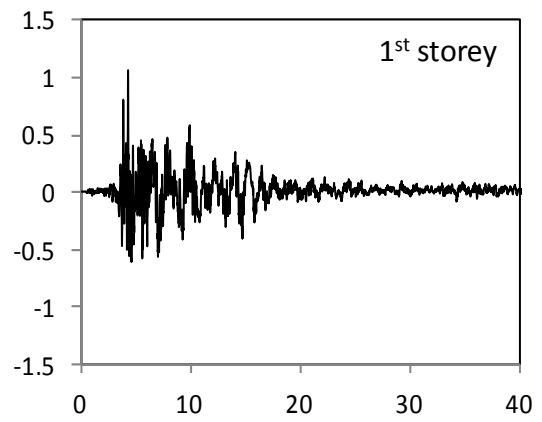
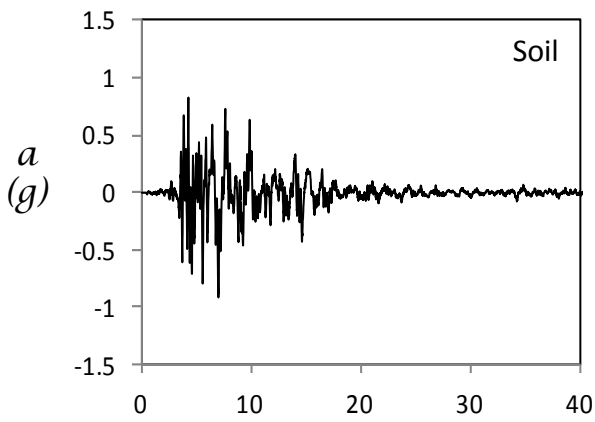
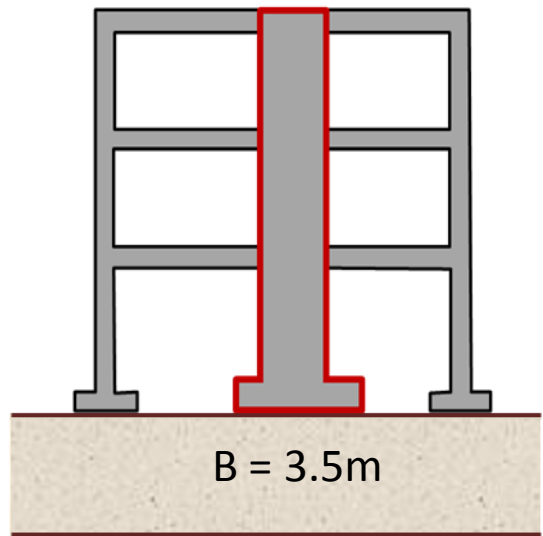
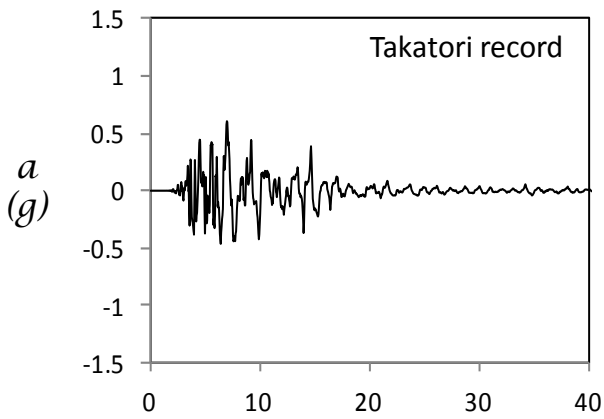

Figure B38. Time histories of storey drift and drift ratio of retrofitted building with rocking isolation ($B = 3.5\text{m}$) while submitted to the record of Rinaldi.



t (sec)

t (sec)

Figure B39. Acceleration time histories measured on the retrofitted building with rocking isolation ($B = 3.5\text{m}$) while submitted to the record of Takatori.

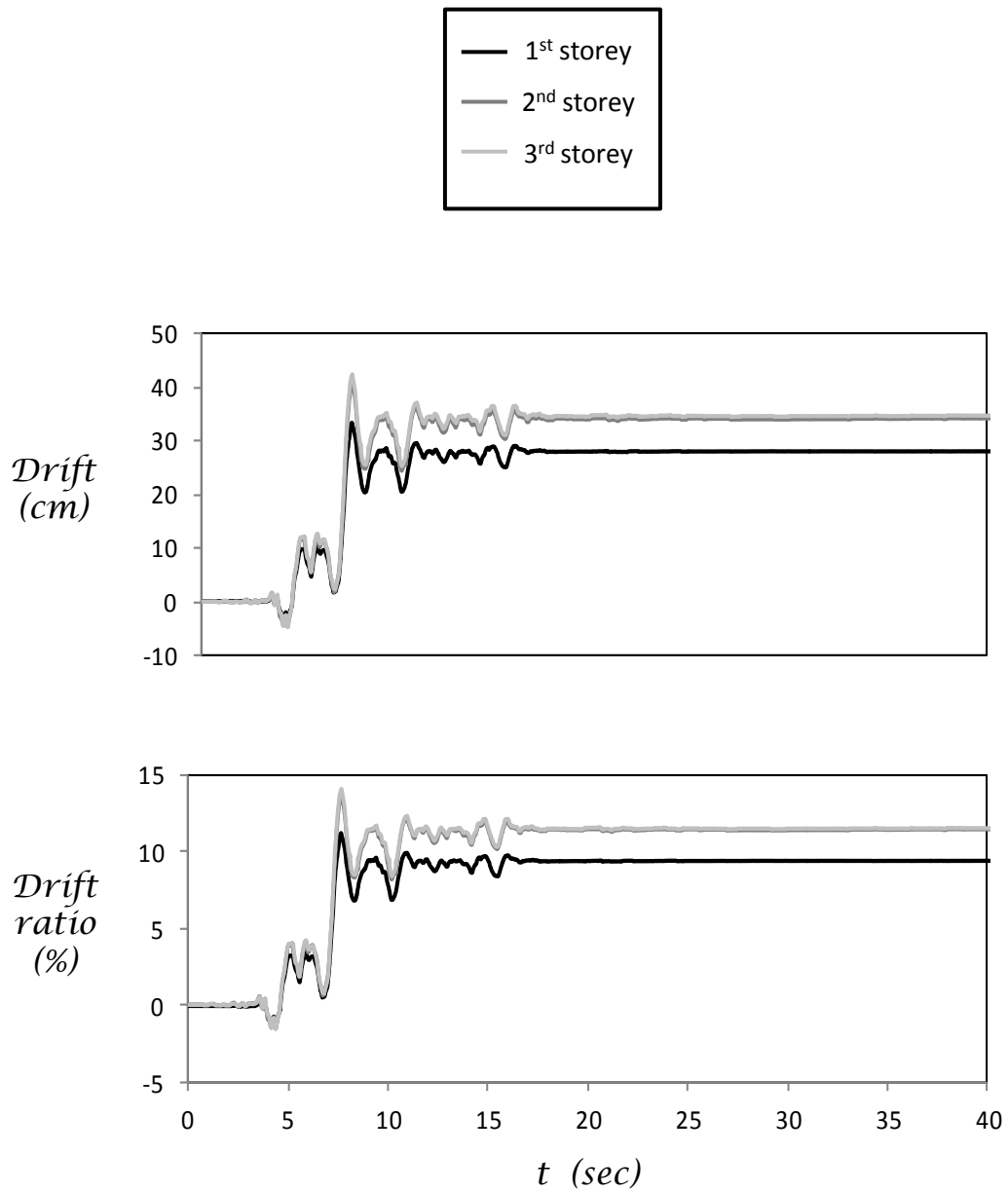

Figure B40. Time histories of storey drift and drift ratio of retrofitted building with rocking isolation ($B = 3.5\text{m}$) while submitted to the record of Takatori.

Retrofitted Building:

Rocking Isolation with Hybrid Foundation

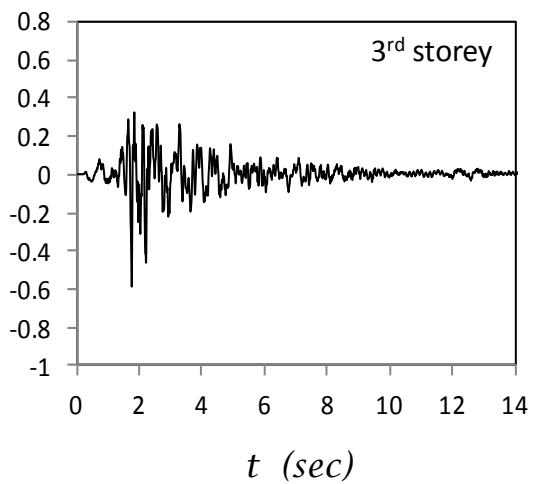
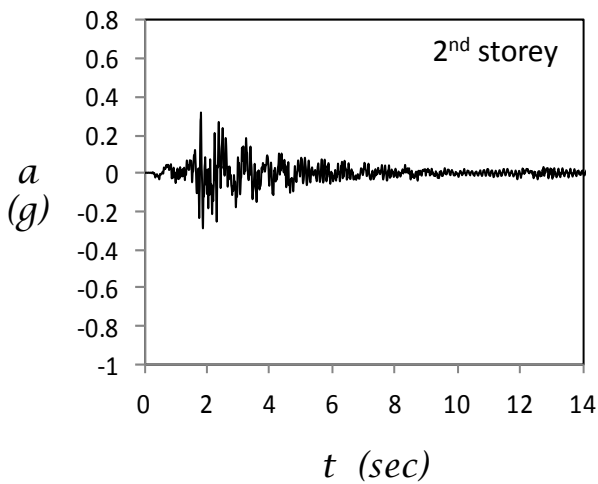
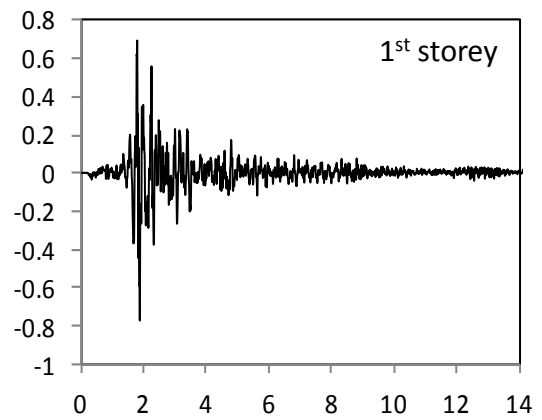
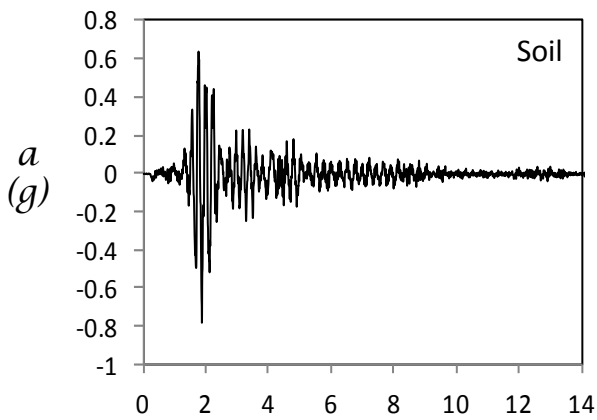
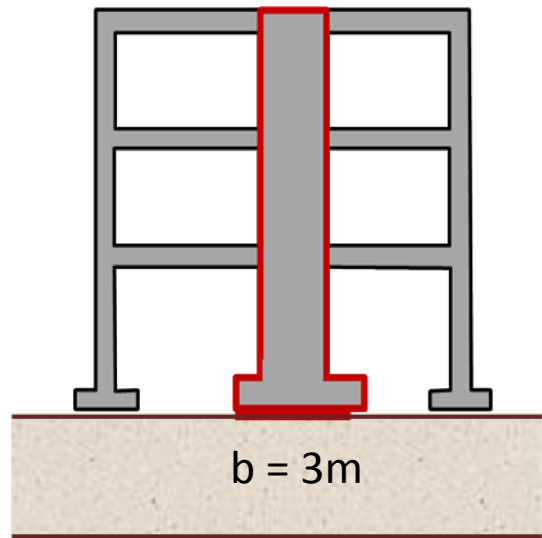
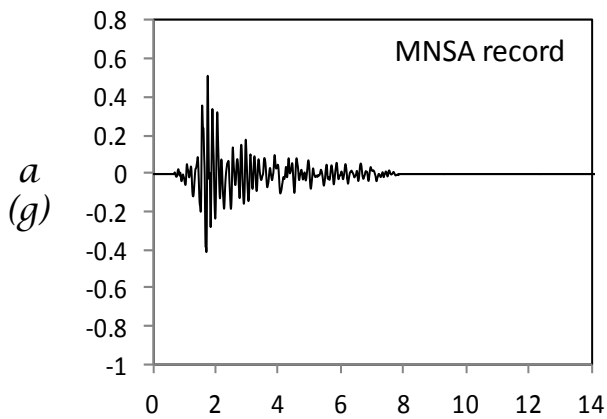

Figure B41. Acceleration time histories measured on the retrofitted building with rocking isolation ($b = 3\text{m}$, $t = 0.05\text{m}$) while submitted to the record of MNSA.

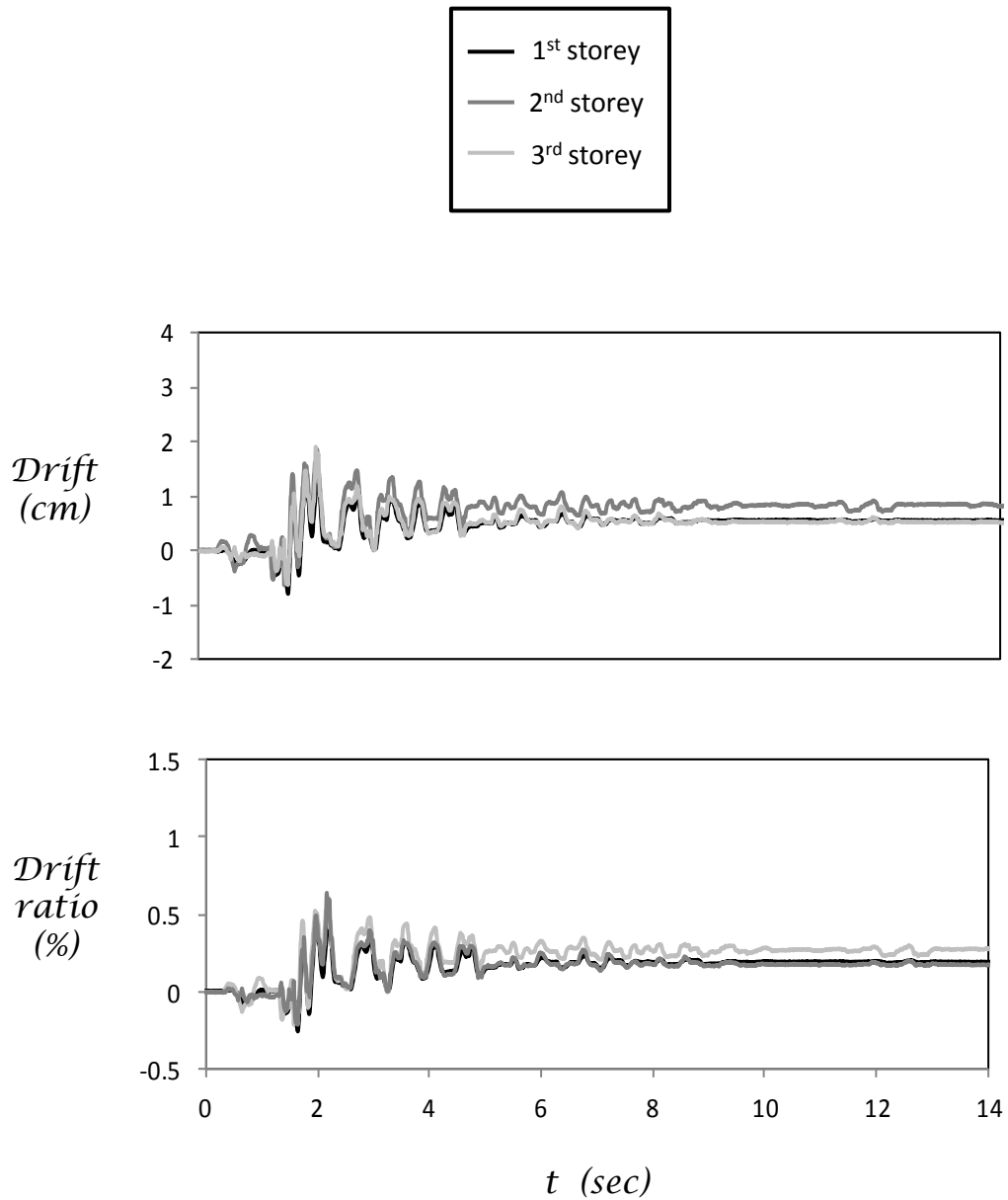

Figure B42. Time histories of storey drift and drift ratio of retrofitted building with rocking isolation ($b = 3\text{m}$, $t = 0.05\text{m}$) while submitted to the record of MNSA.

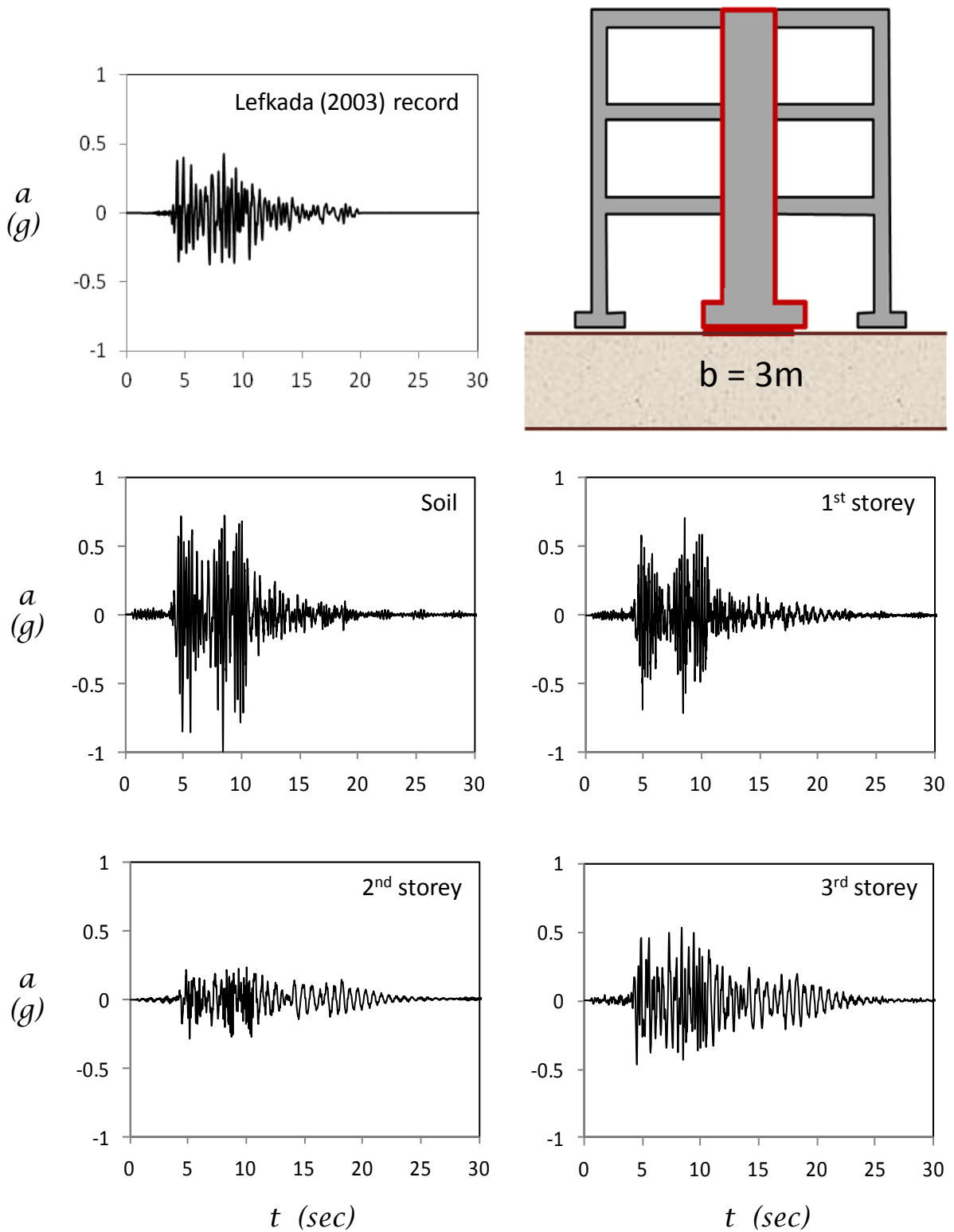

Figure B43. Acceleration time histories measured on the retrofitted building with rocking isolation ($b = 3\text{m}$, $t = 0.05\text{m}$) while submitted to the record of Lefkada (2003).

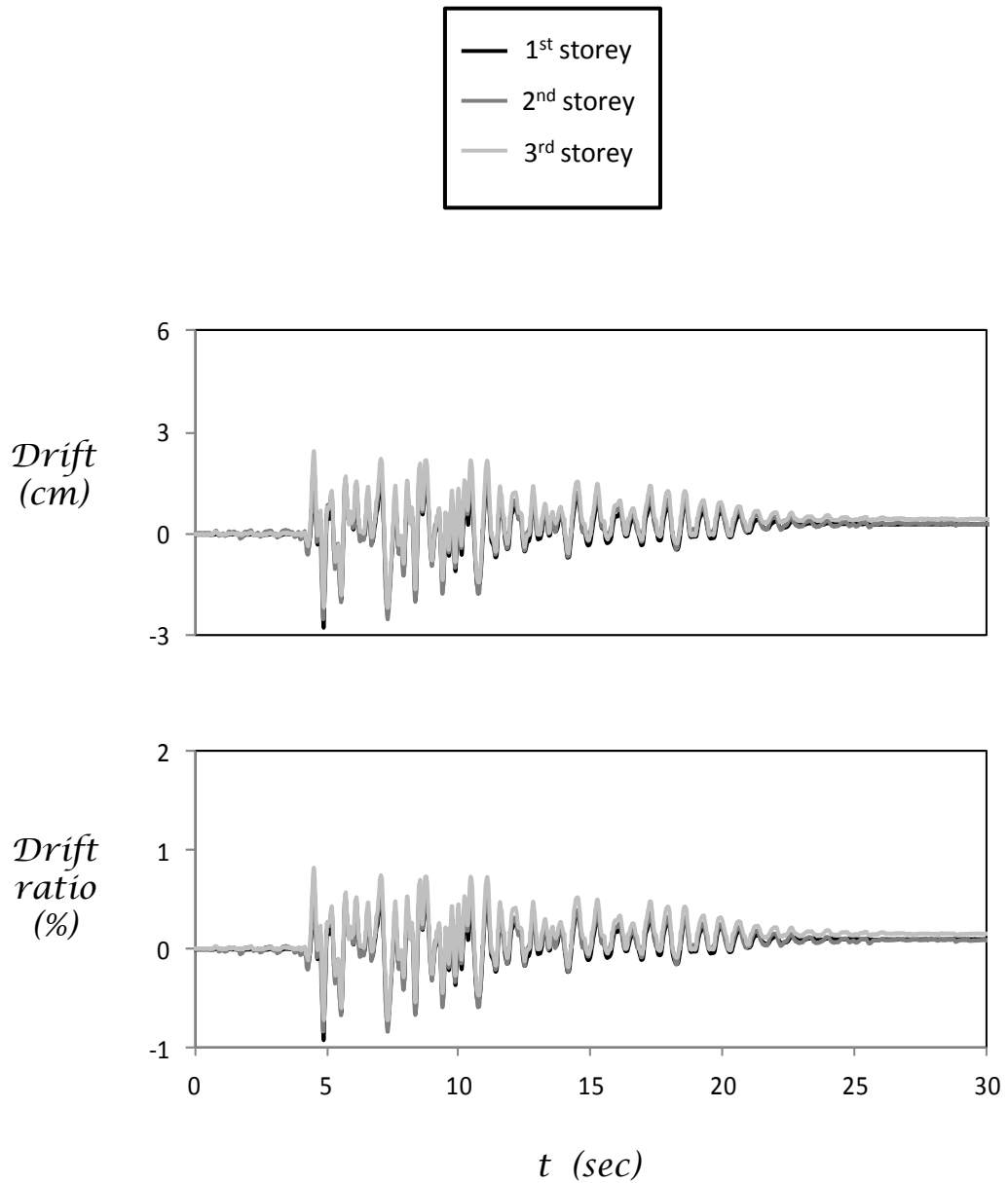

Figure B44. Time histories of storey drift and drift ratio of retrofitted building with rocking isolation ($b = 3\text{m}$, $t = 0.05\text{m}$) while submitted to the record of Lefkada (2003).

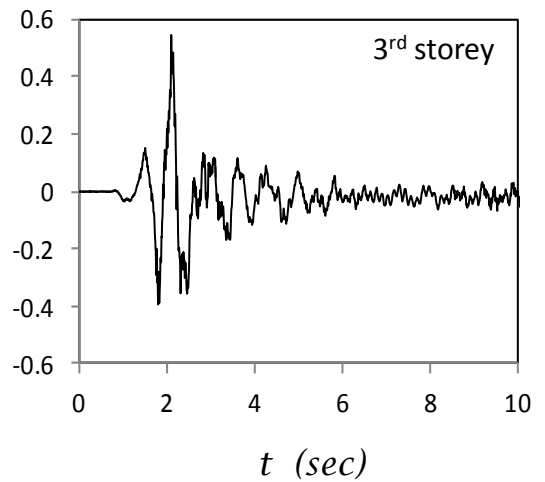
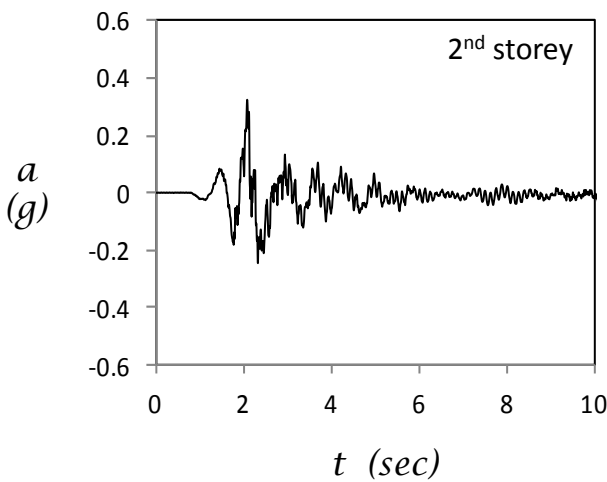
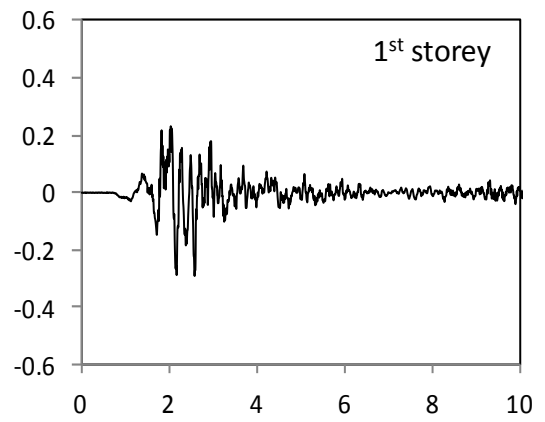
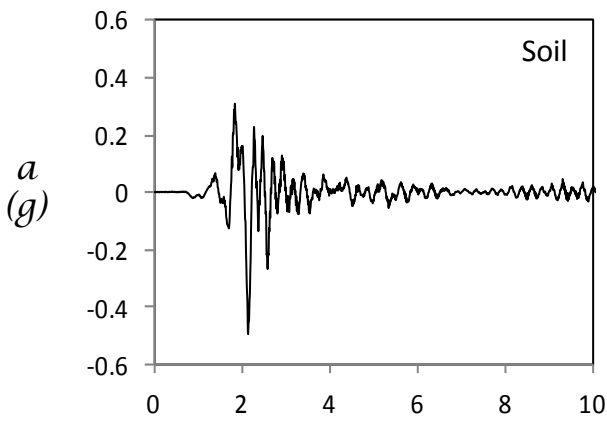
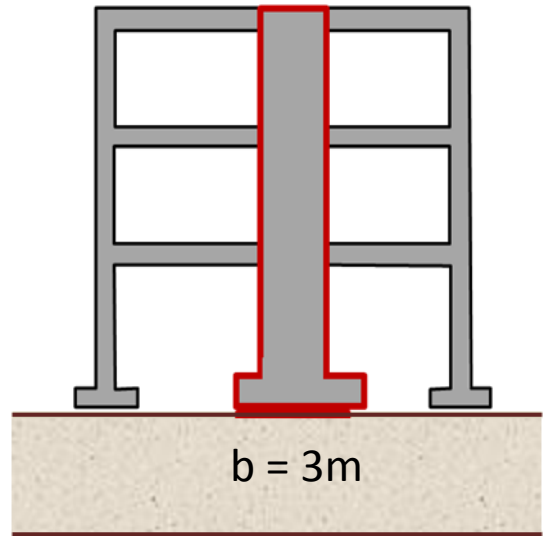
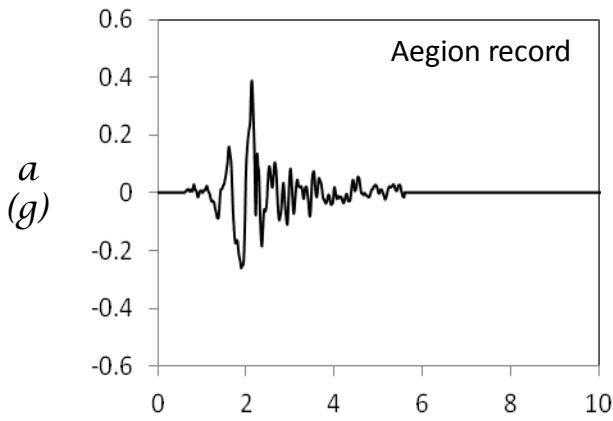

Figure B45. Acceleration time histories measured on the retrofitted building with rocking isolation ($b = 3\text{m}$, $t = 0.05\text{m}$) while submitted to the record of Aegion.

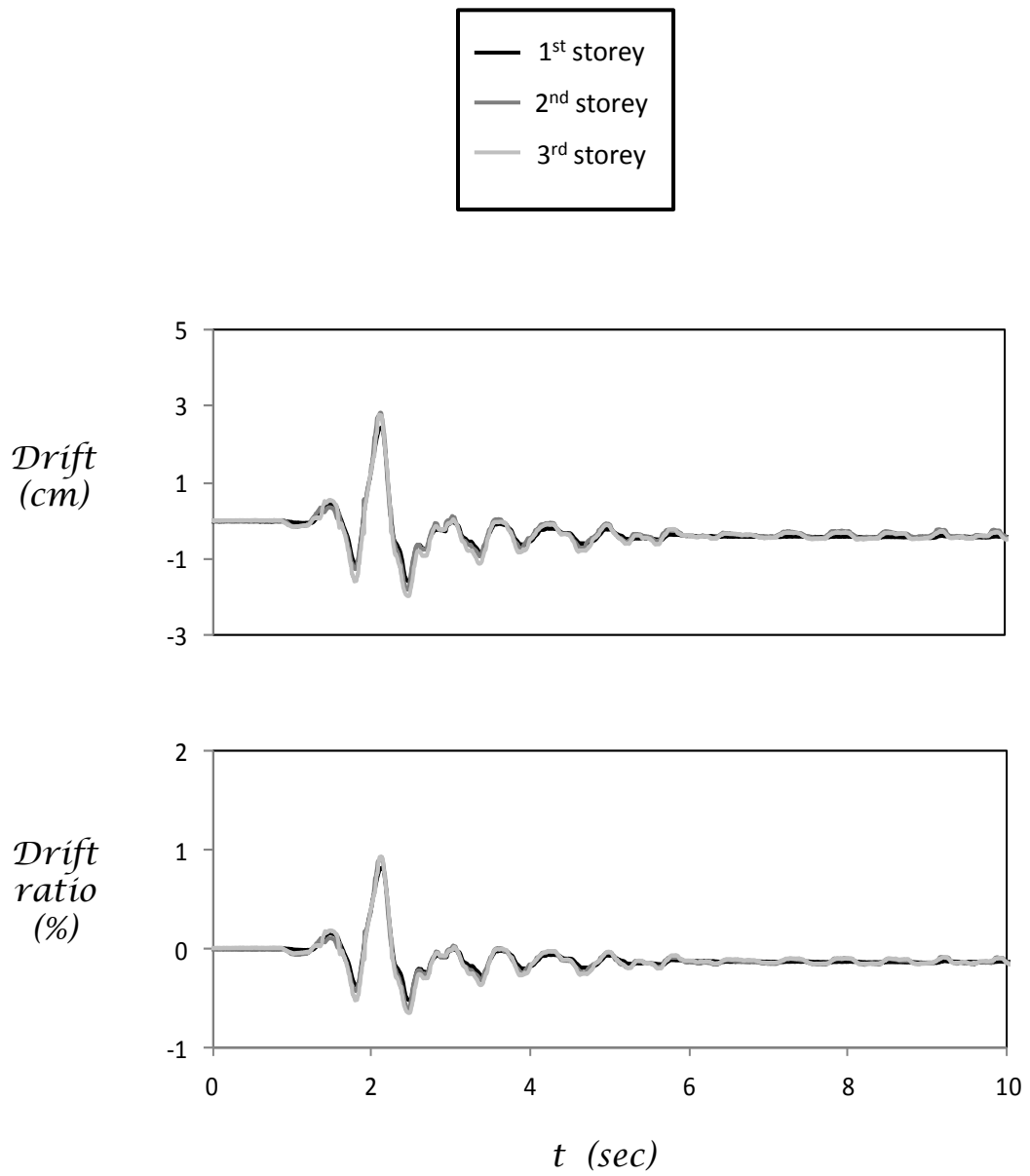
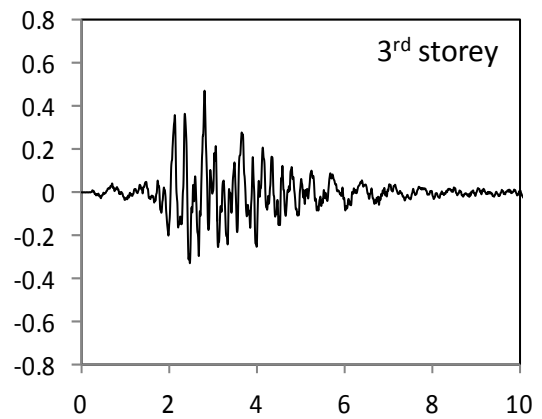
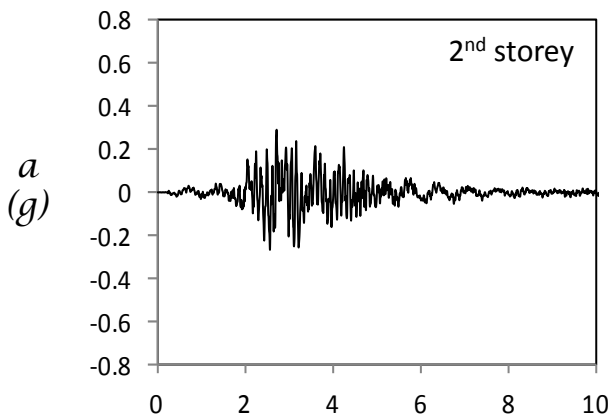
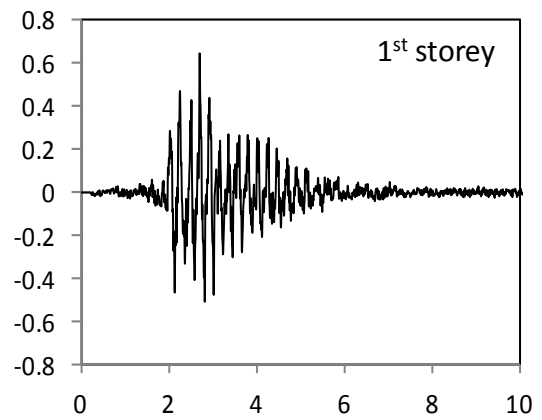
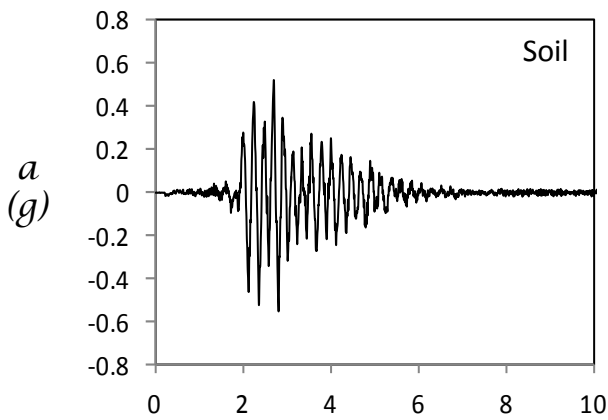
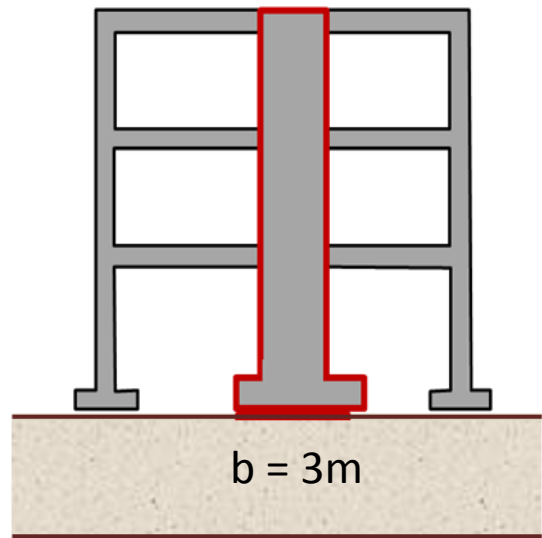
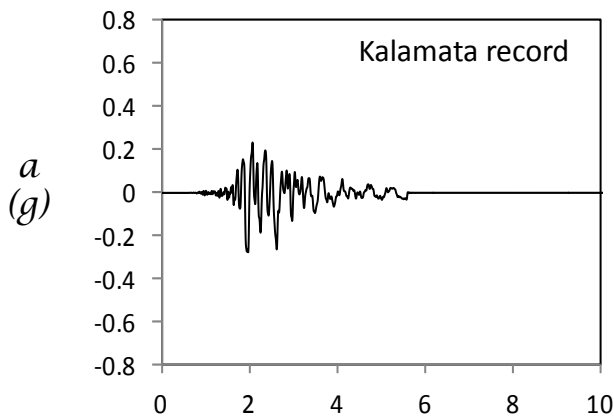

Figure B46. Time histories of storey drift and drift ratio of retrofitted building with rocking isolation ($b = 3\text{m}$, $t = 0.05\text{m}$) while submitted to the record of Aegion.



t (sec)

t (sec)

Figure B47. Acceleration time histories measured on the retrofitted building with rocking isolation ($b = 3\text{m}$, $t = 0.05\text{m}$) while submitted to the record of Kalamata.

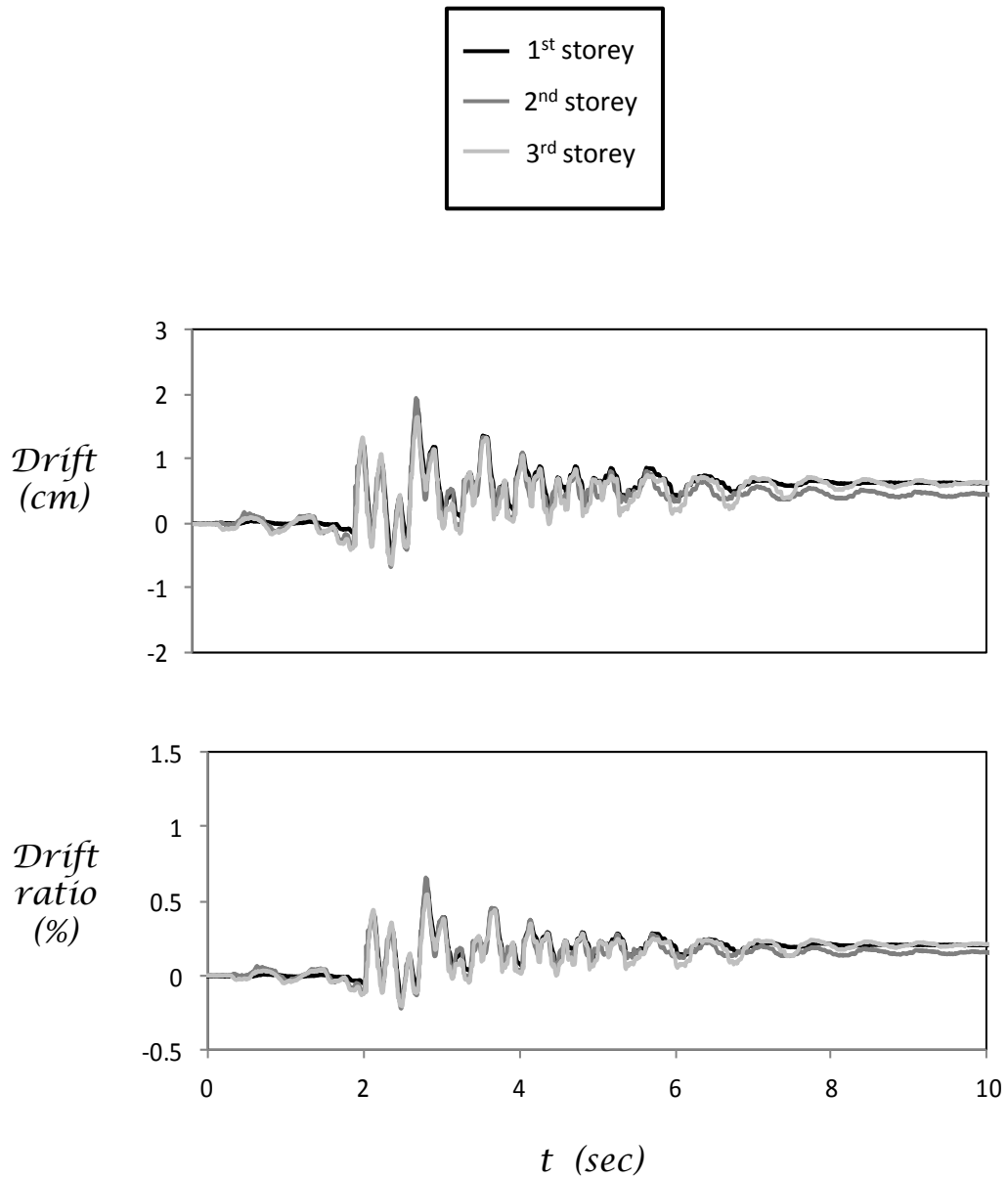
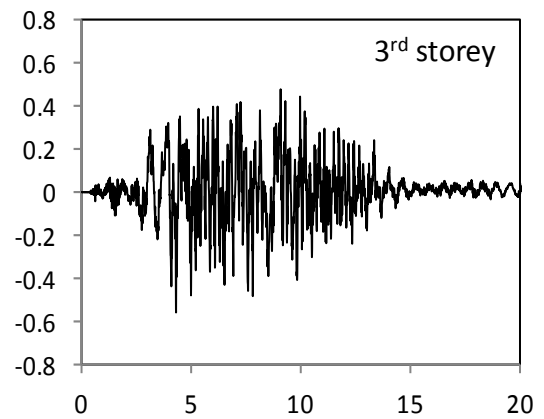
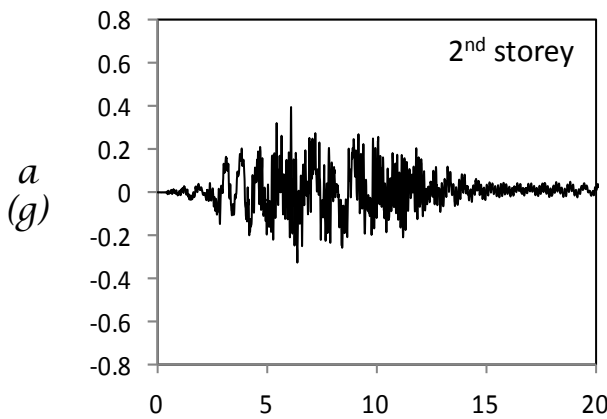
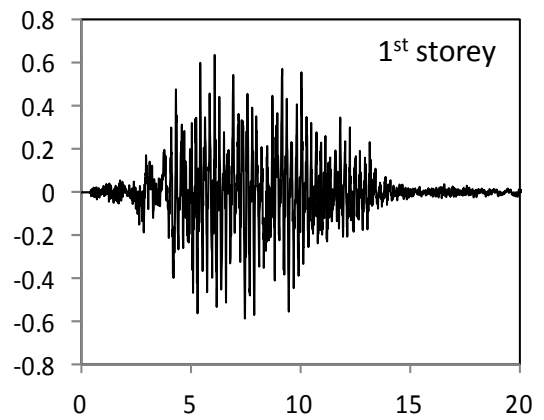
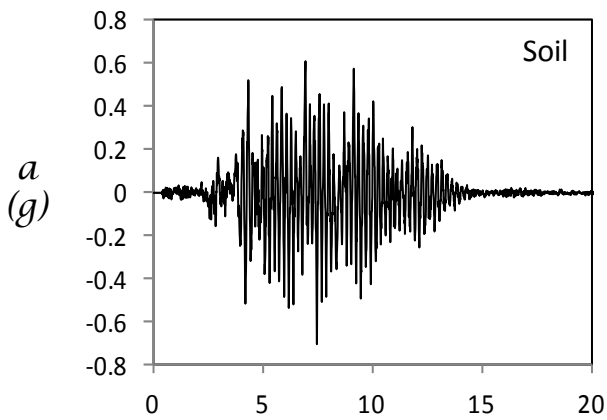
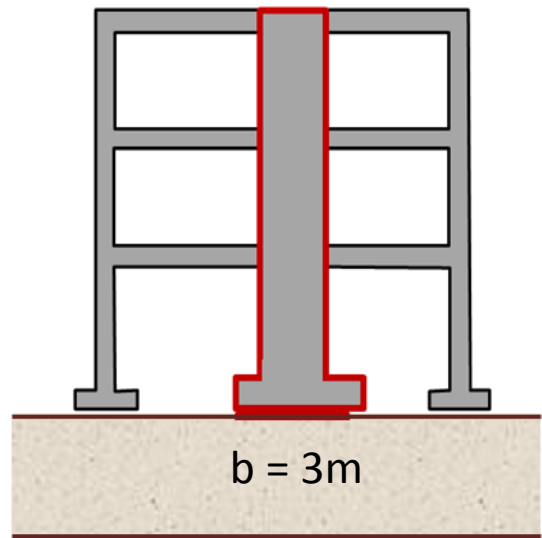
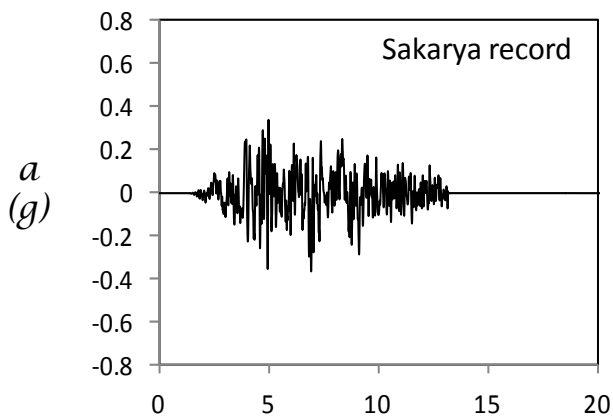

Figure B48. Time histories of storey drift and drift ratio of retrofitted building with rocking isolation ($b = 3\text{m}$, $t = 0.05\text{m}$) while submitted to the record of Kalamata.



t (sec)

t (sec)

Figure B49. Acceleration time histories measured on the retrofitted building with rocking isolation ($b = 3\text{m}$, $t = 0.05\text{m}$) while submitted to the record of Sakarya.

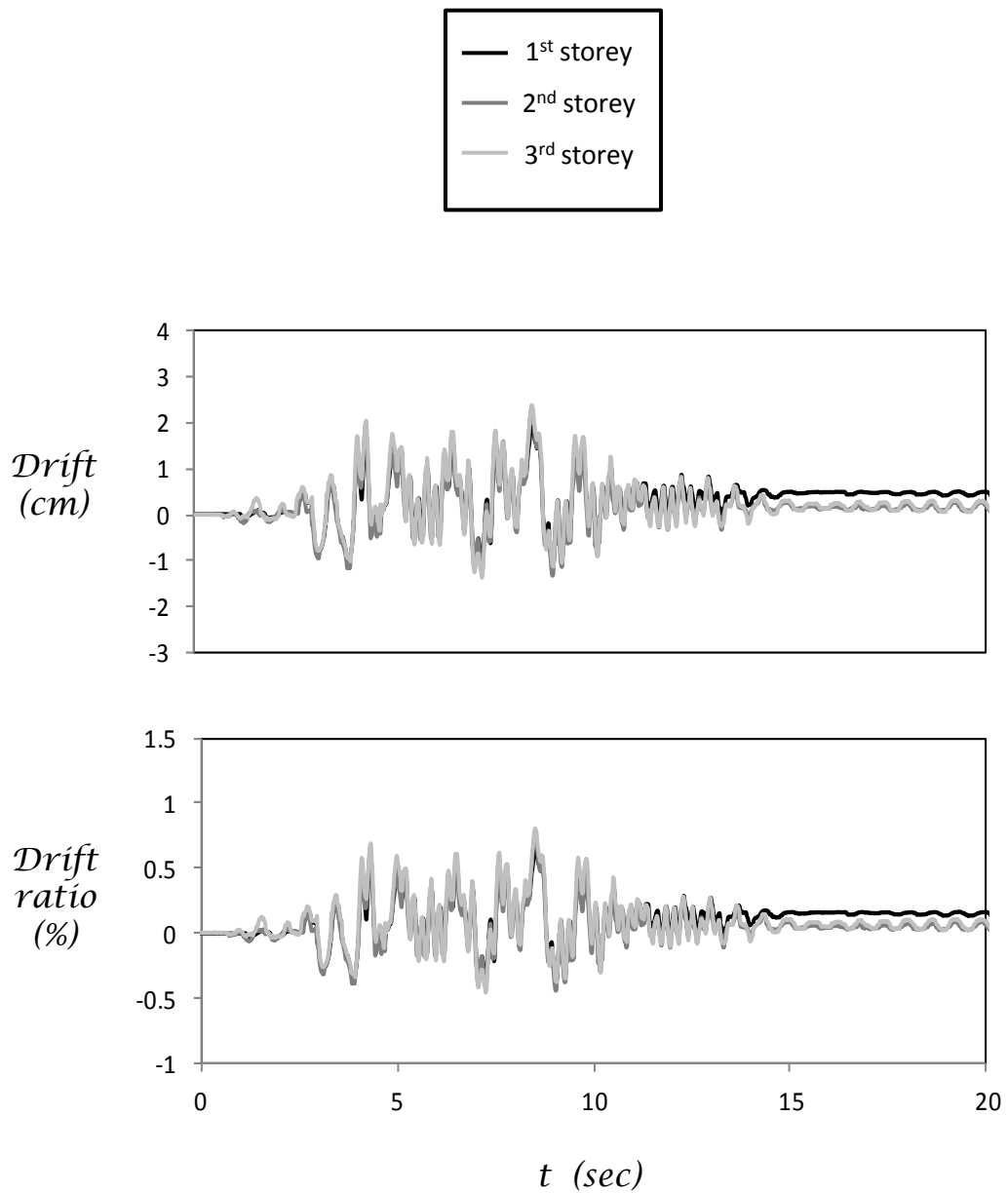

Figure B50. Time histories of storey drift and drift ratio of retrofitted building with rocking isolation ($b = 3\text{m}$, $t = 0.05\text{m}$) while submitted to the record of Sakarya.

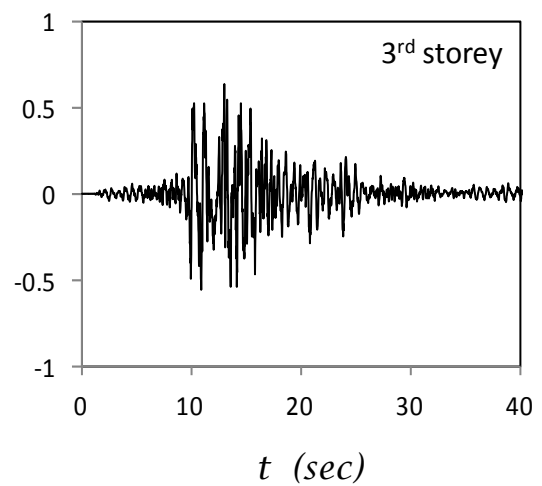
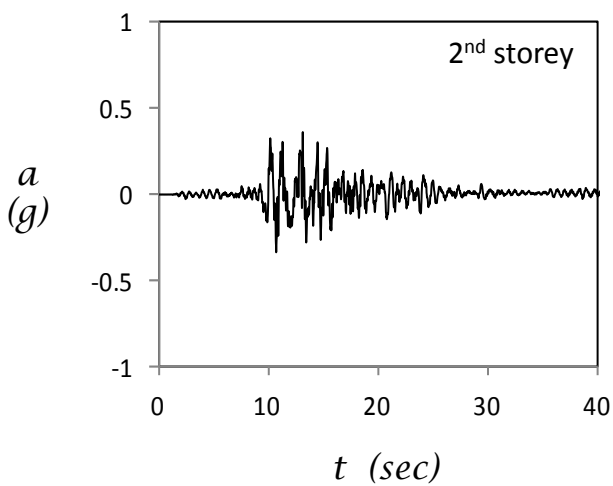
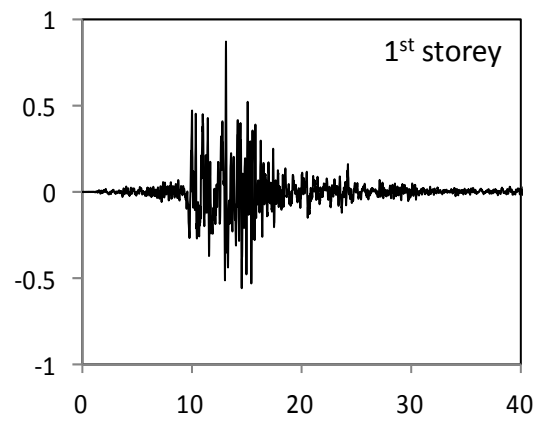
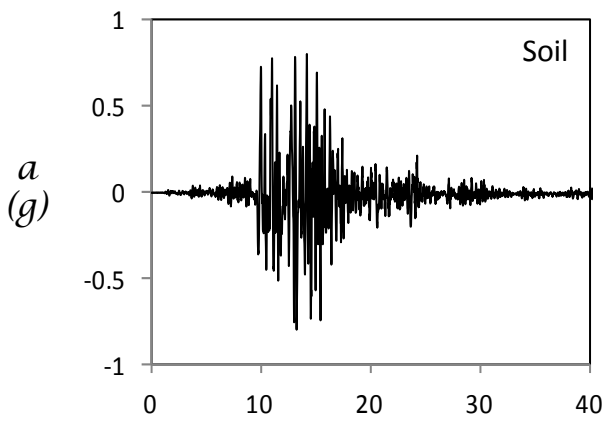
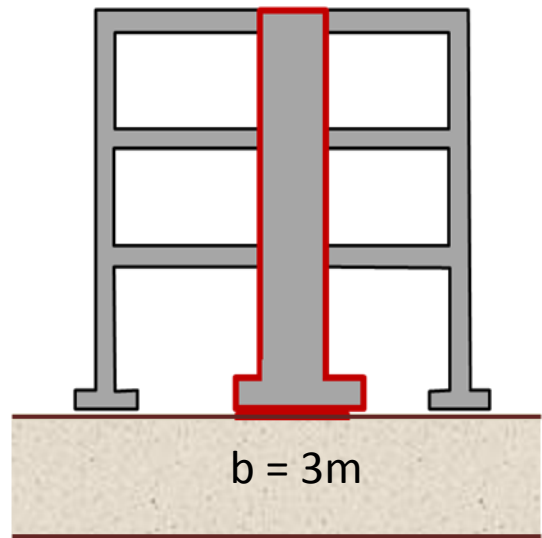
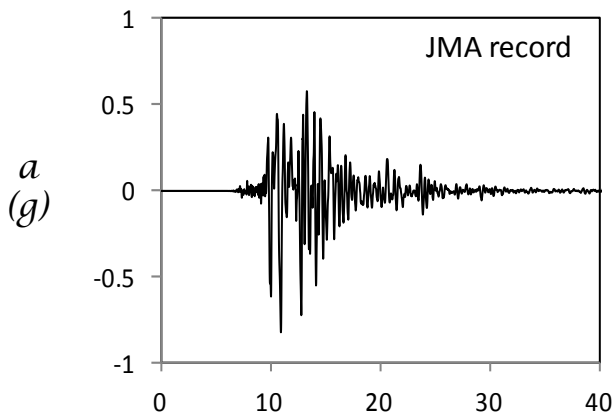

Figure B51. Acceleration time histories measured on the retrofitted building with rocking isolation ($b = 3\text{m}$, $t = 0.05\text{m}$) while submitted to the record of JMA.

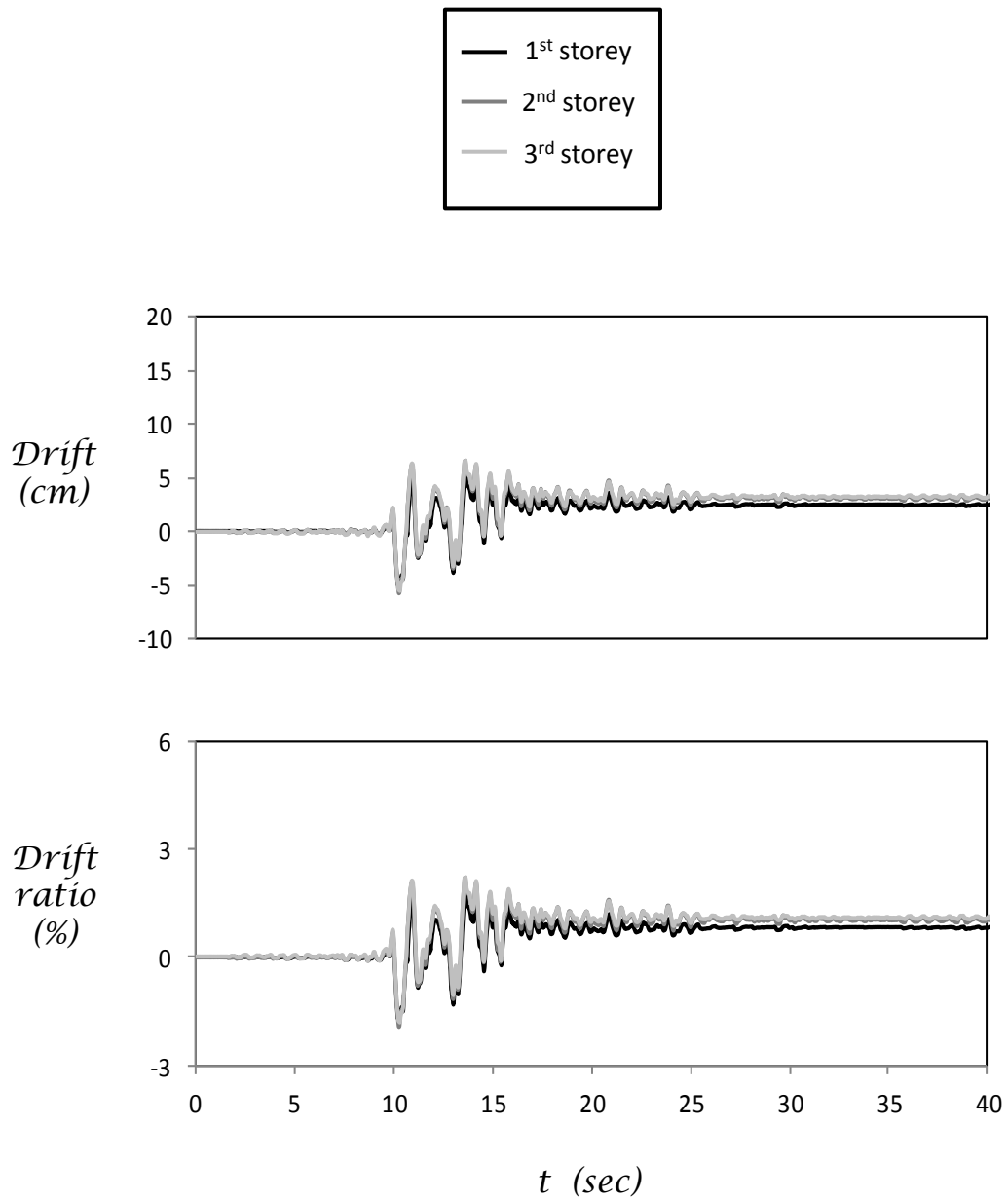

Figure B52. Time histories of storey drift and drift ratio of retrofitted building with rocking isolation ($b = 3\text{m}$, $t = 0.05\text{m}$) while submitted to the record of JMA.

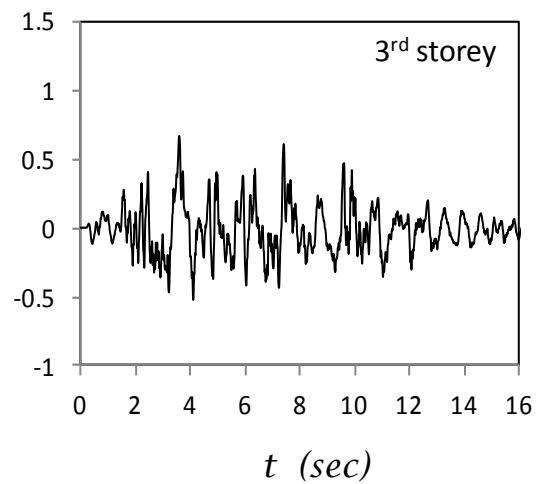
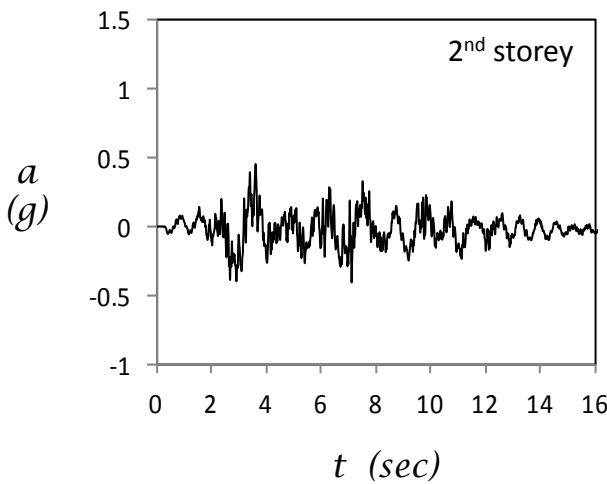
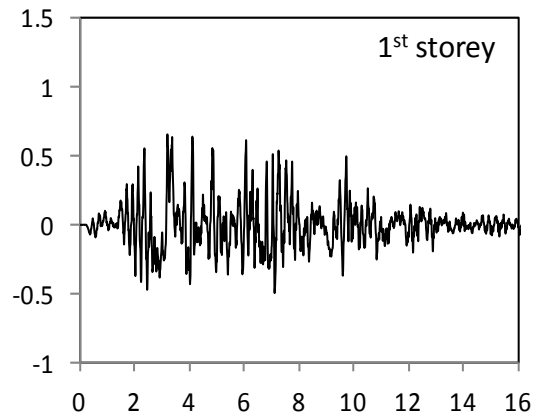
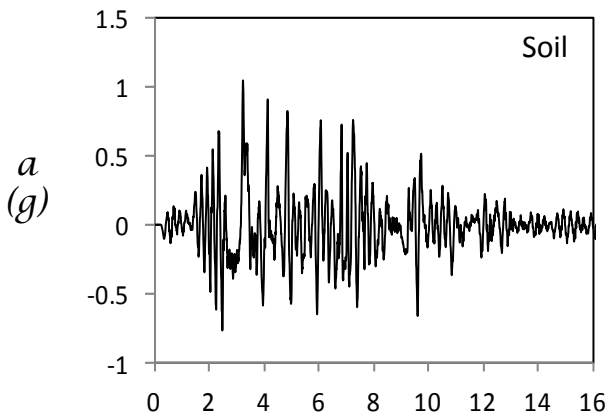
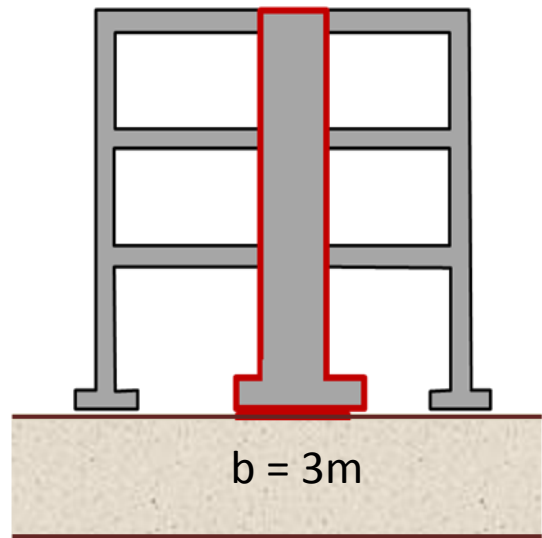
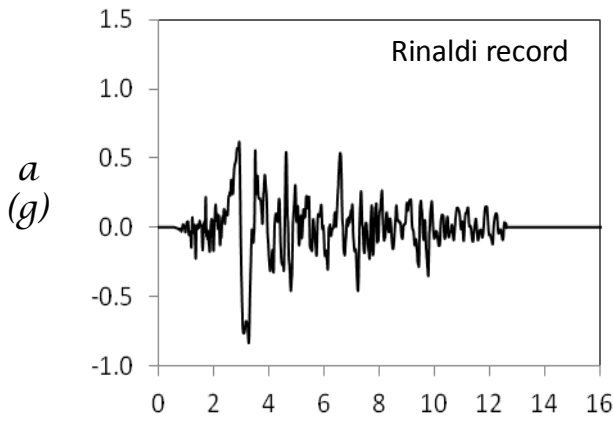

Figure B53. Acceleration time histories measured on the retrofitted building with rocking isolation ($b = 3\text{m}$, $t = 0.05\text{m}$) while submitted to the record of Rinaldi.

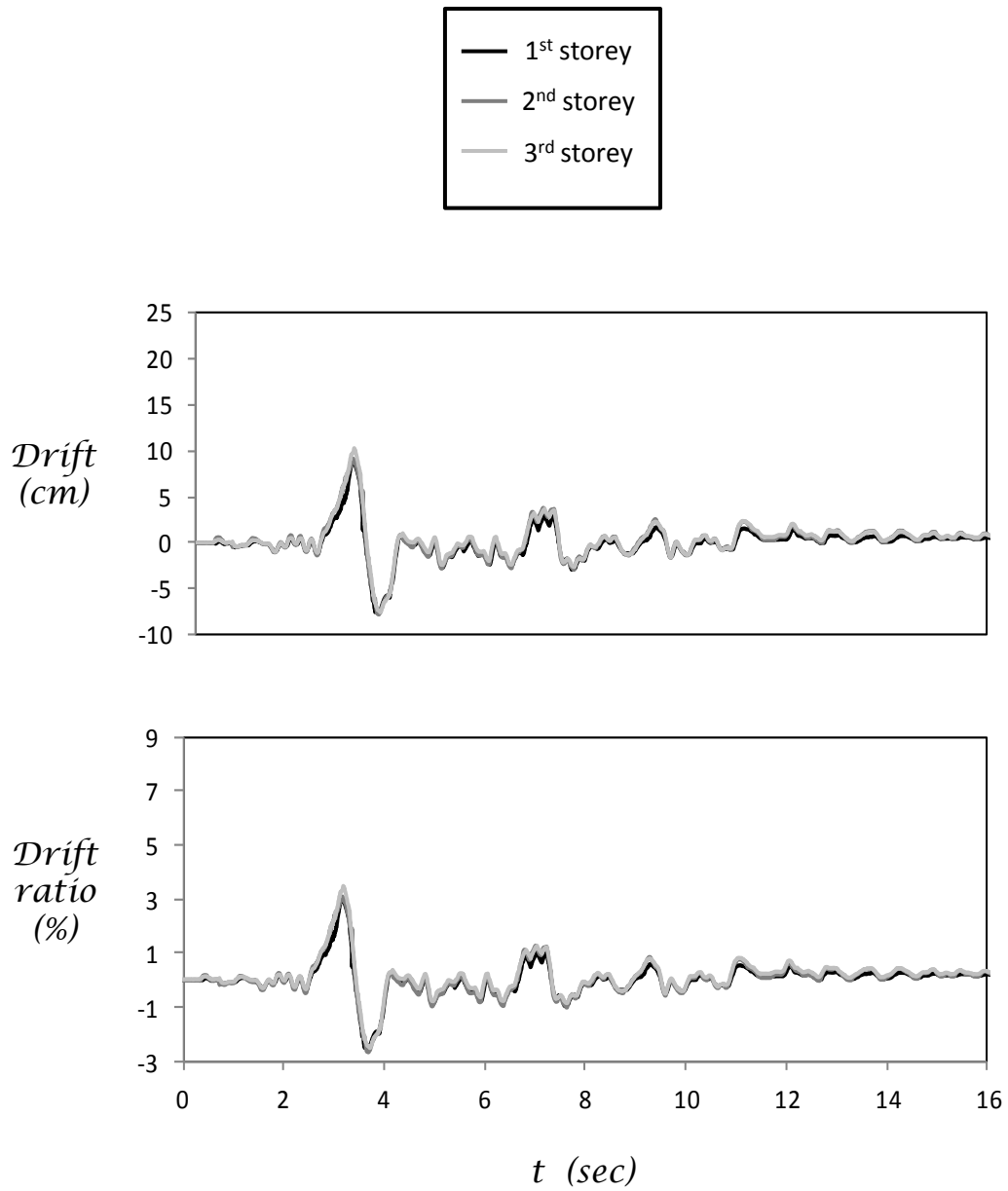

Figure B54. Time histories of storey drift and drift ratio of retrofitted building with rocking isolation ($b = 3\text{m}$, $t = 0.05\text{m}$) while submitted to the record of Rinaldi.

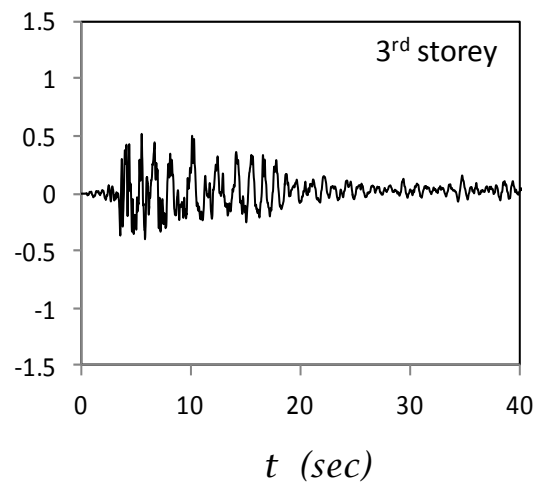
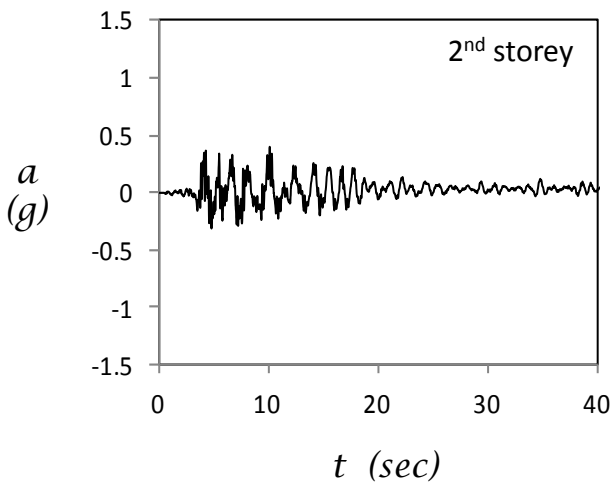
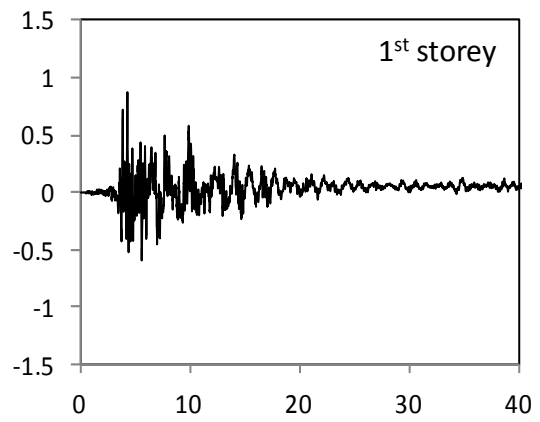
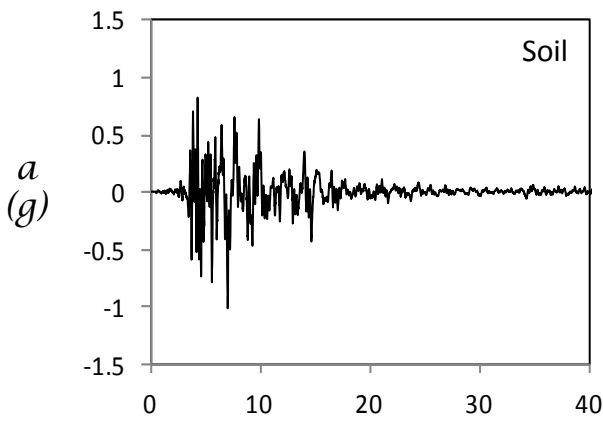
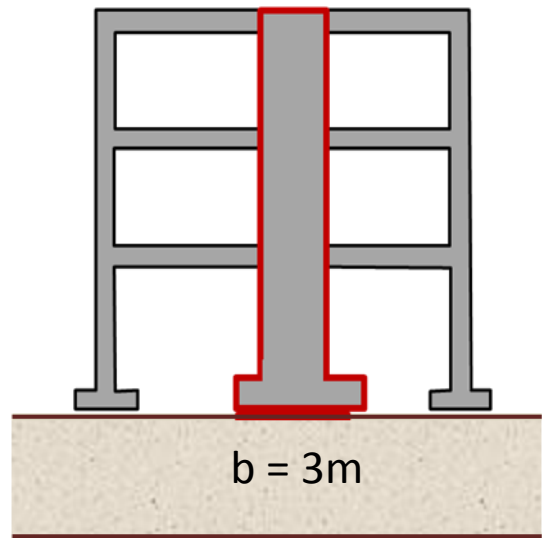
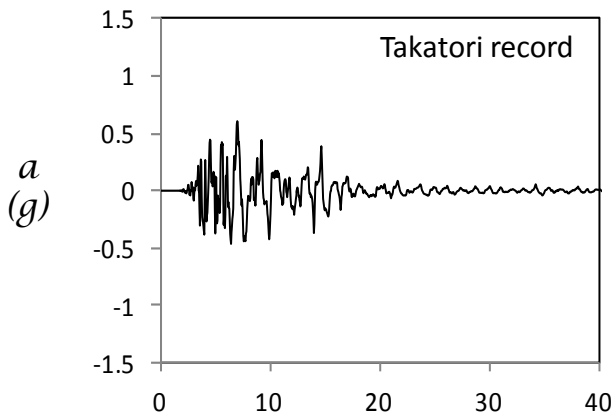

Figure B55. Acceleration time histories measured on the retrofitted building with rocking isolation ($b = 3\text{m}$, $t = 0.05\text{m}$) while submitted to the record of Takatori.

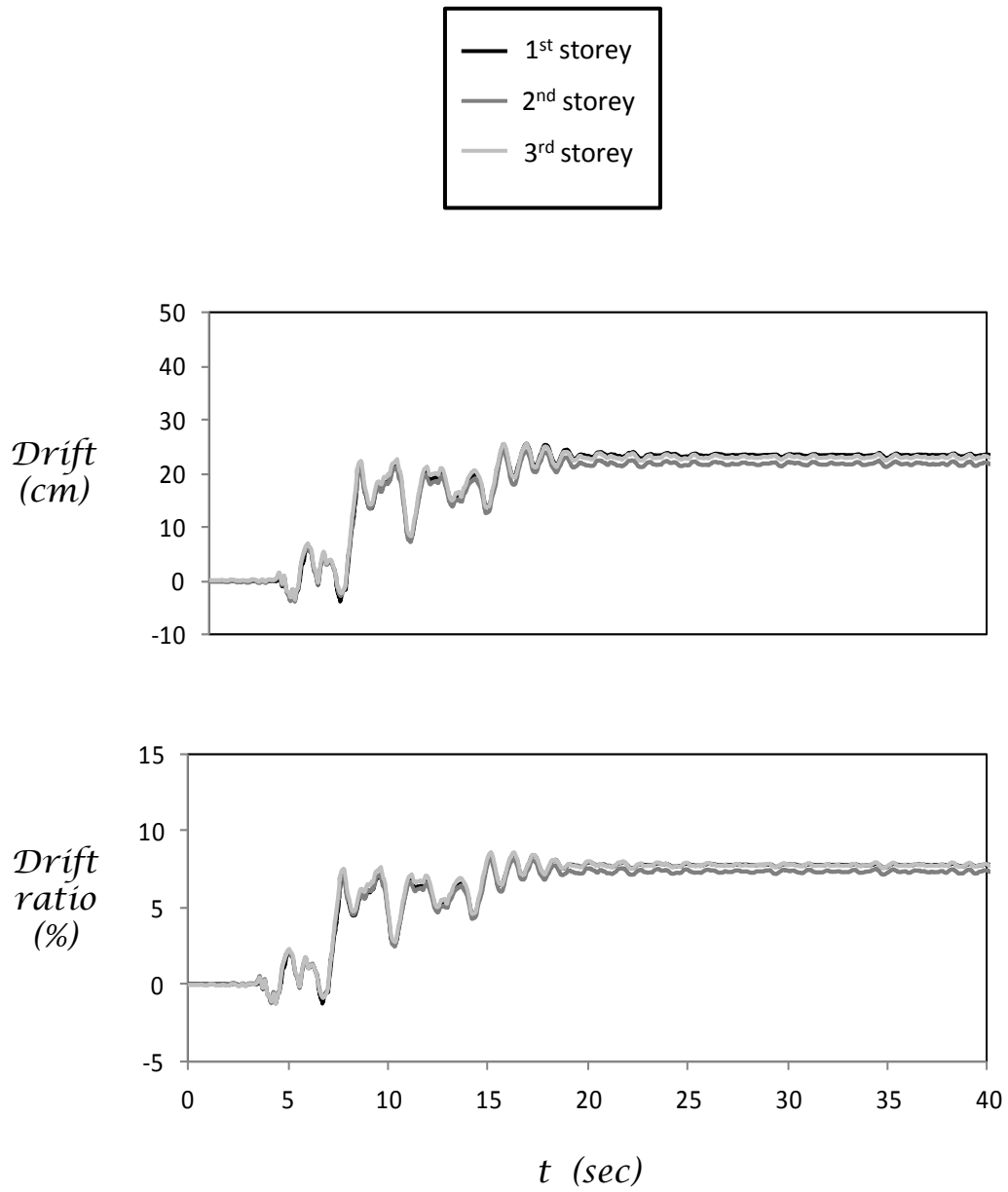
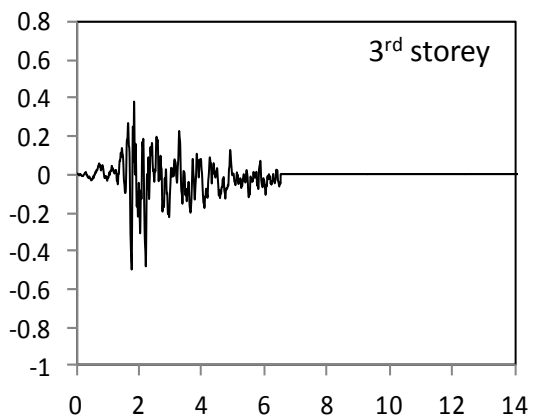
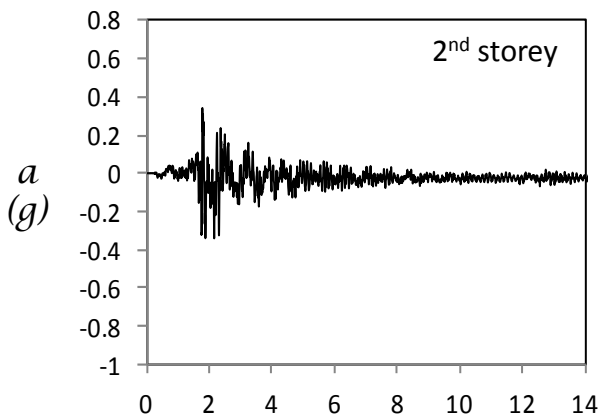
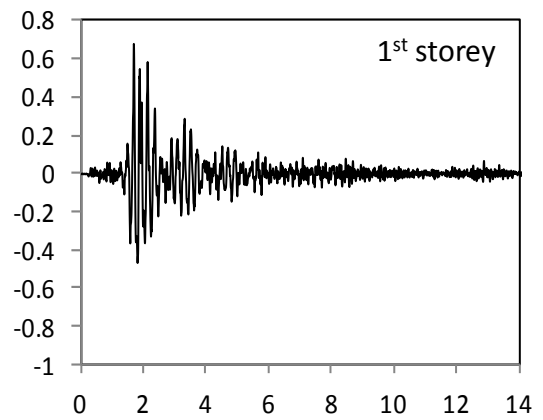
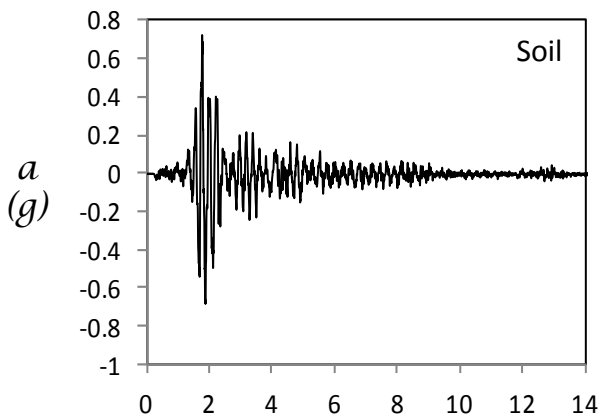
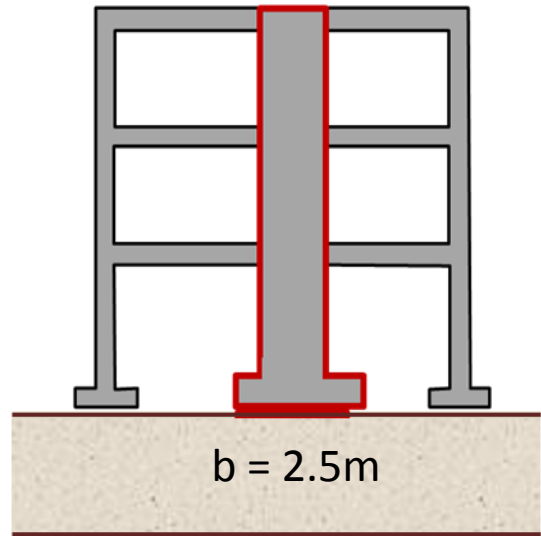
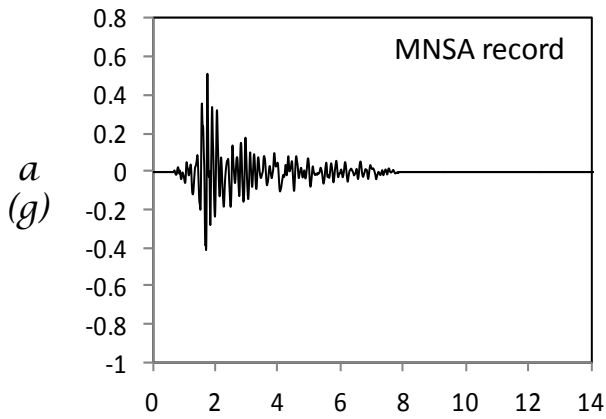

Figure B56. Time histories of storey drift and drift ratio of retrofitted building with rocking isolation ($b = 3\text{m}$, $t = 0.05\text{m}$) while submitted to the record of Takatori.



t (sec)

t (sec)

Figure B57. Acceleration time histories measured on the retrofitted building with rocking isolation ($b = 2.5\text{m}$, $t = 0.05\text{m}$) while submitted to the record of MNSA.

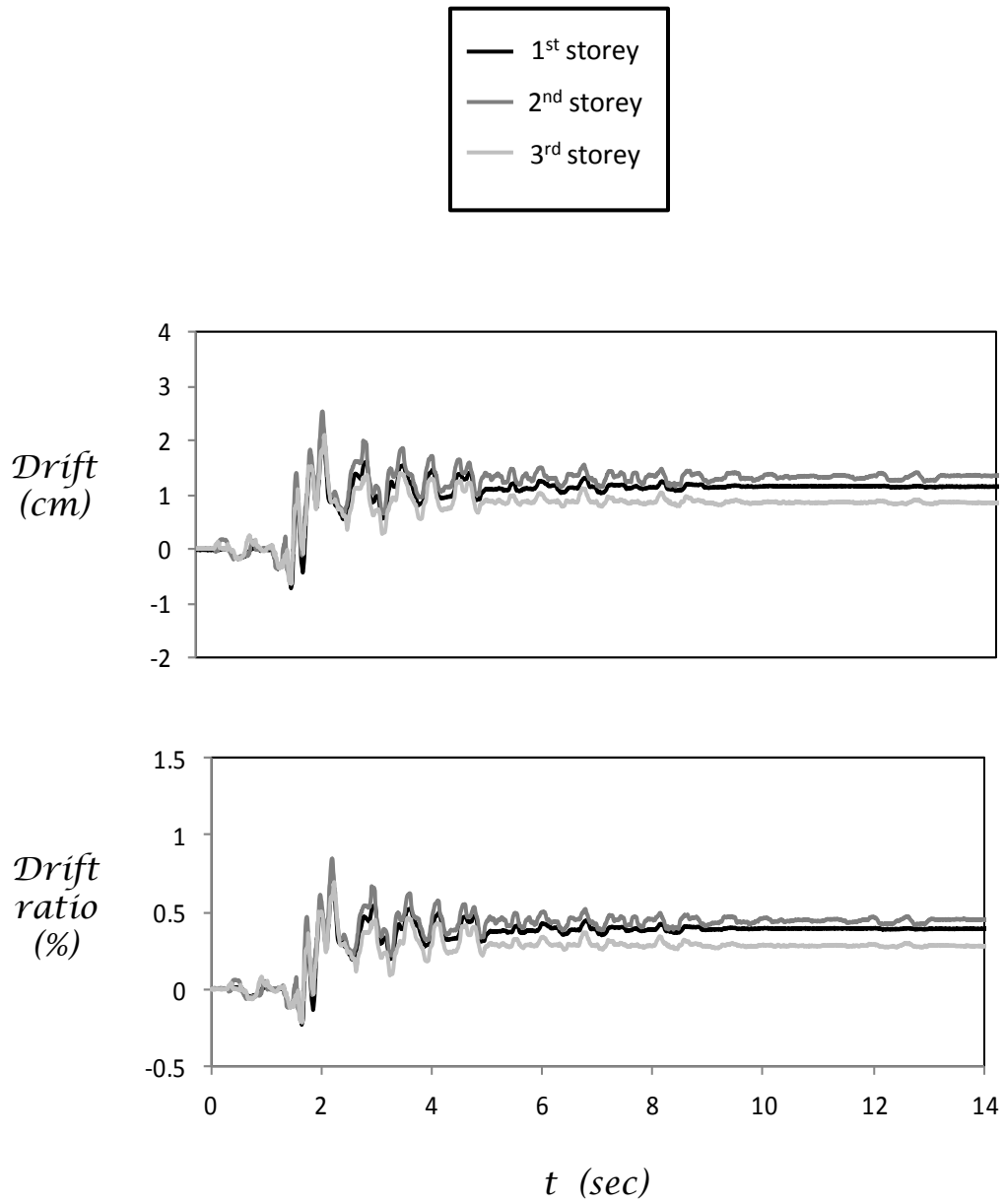
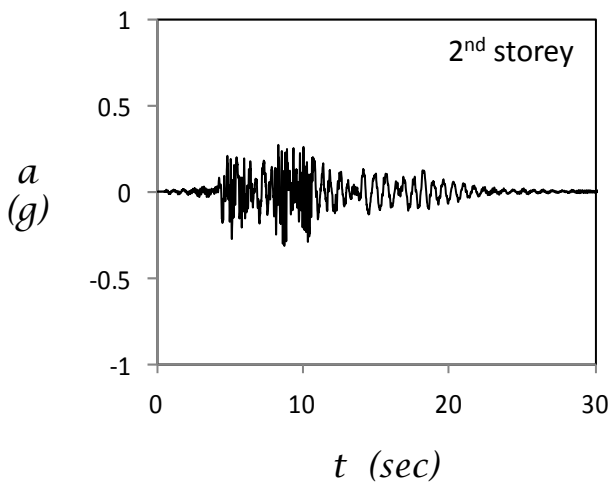
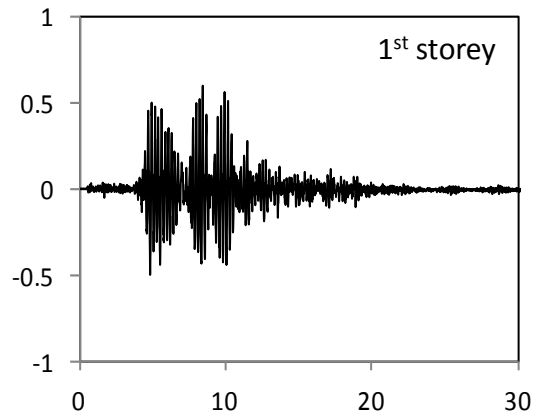
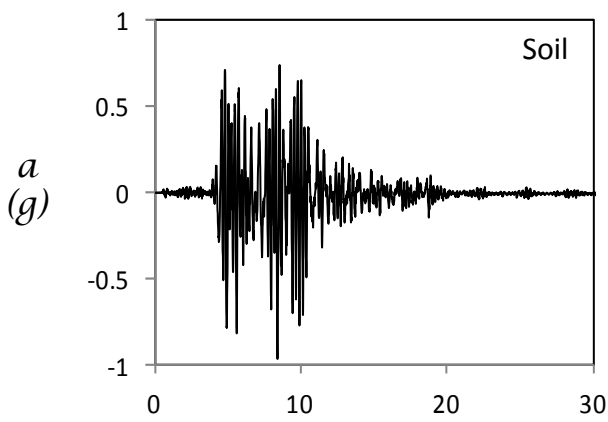
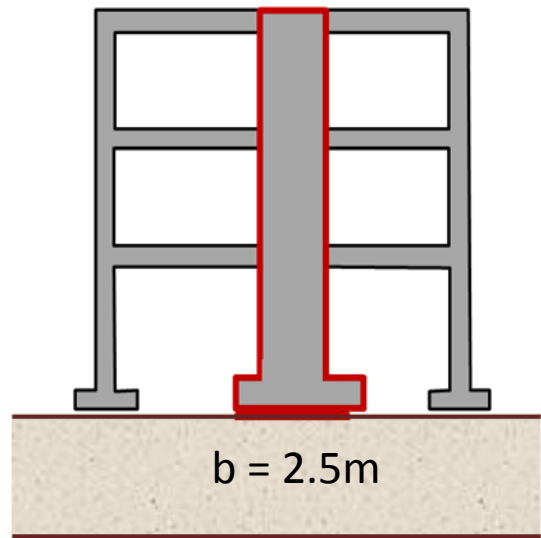
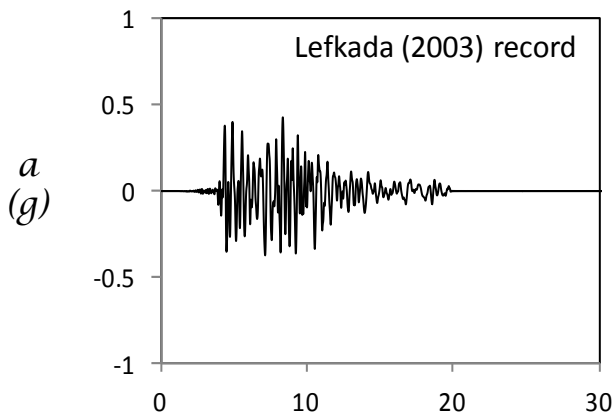

Figure B58. Time histories of storey drift and drift ratio of retrofitted building with rocking isolation ($b = 2.5\text{m}$, $t = 0.05\text{m}$) while submitted to the record of MNSA.



$t \text{ (sec)}$

Figure B59. Acceleration time histories measured on the retrofitted building with rocking isolation ($b = 2.5\text{m}$, $t = 0.05\text{m}$) while submitted to the record of Lefkada (2003).

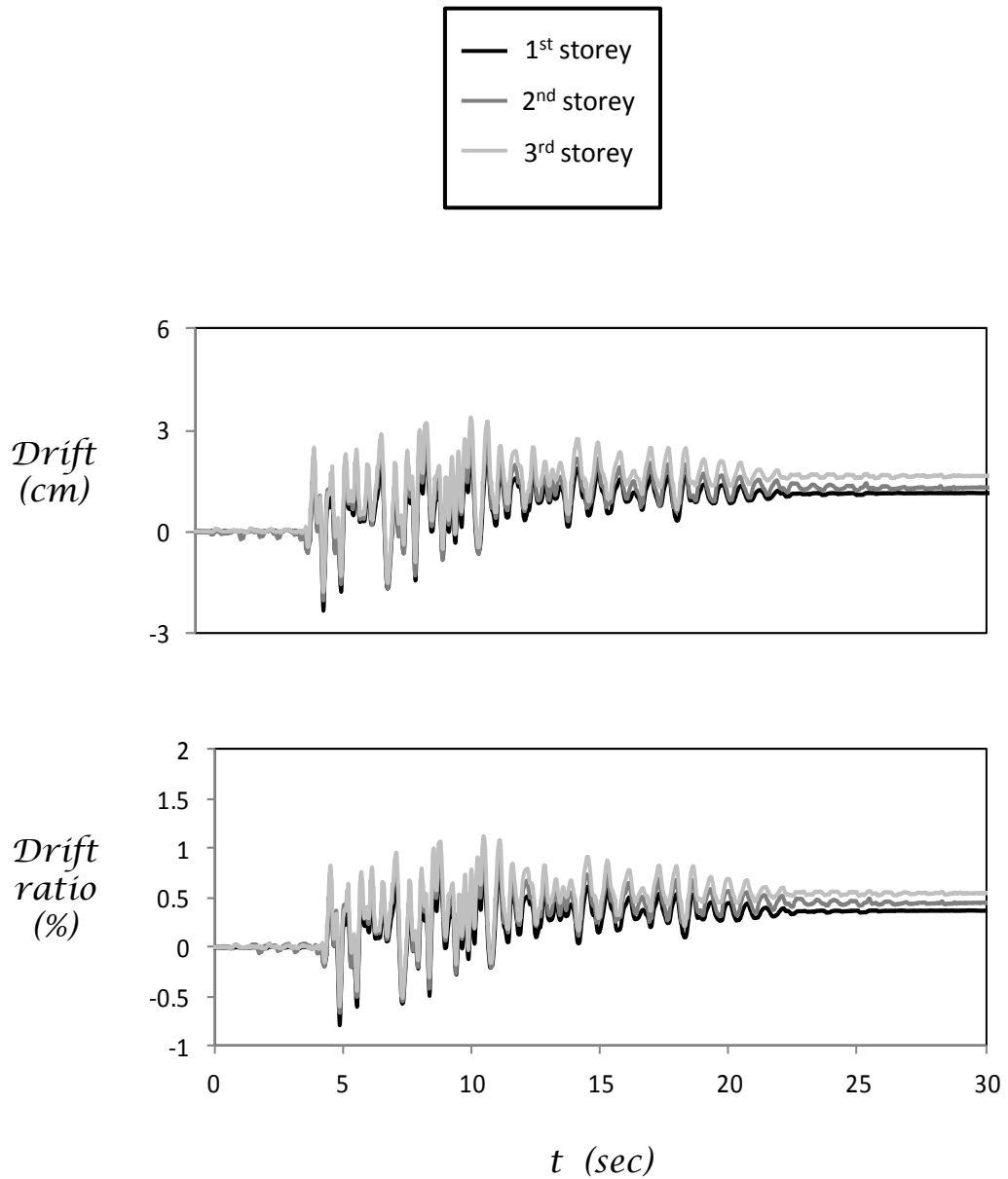

Figure B60. Time histories of storey drift and drift ratio of retrofitted building with rocking isolation ($b = 2.5\text{m}$, $t = 0.05\text{m}$) while submitted to the record of Lefkada (2003).

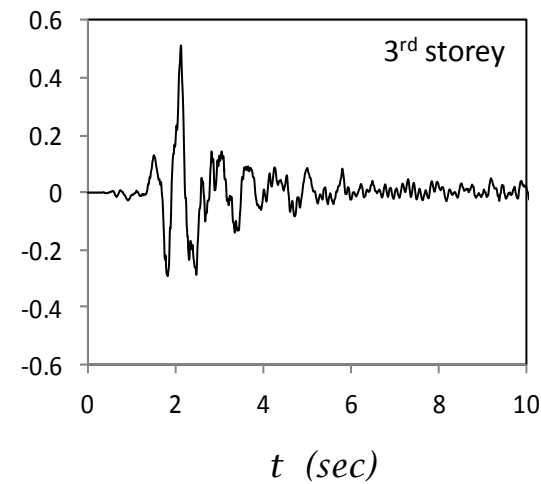
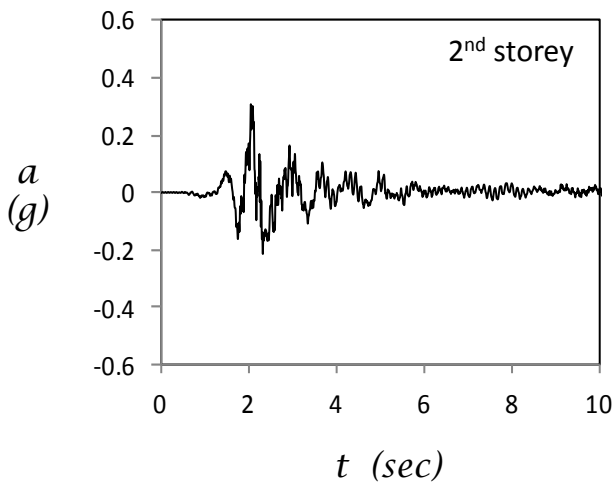
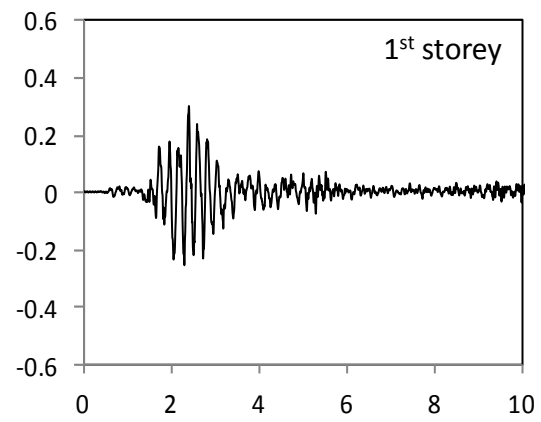
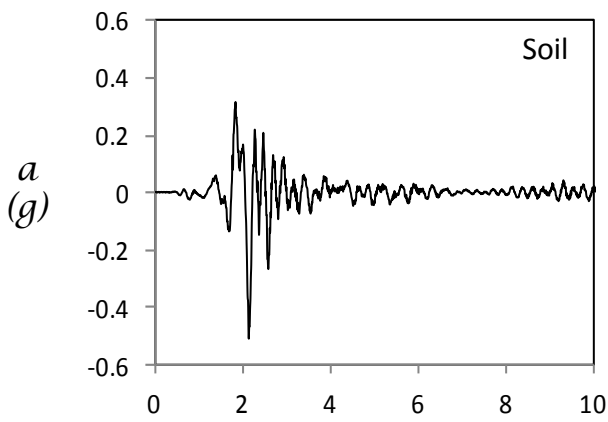
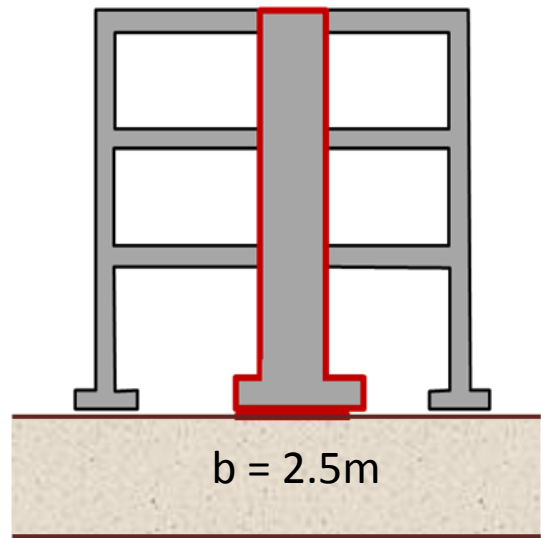
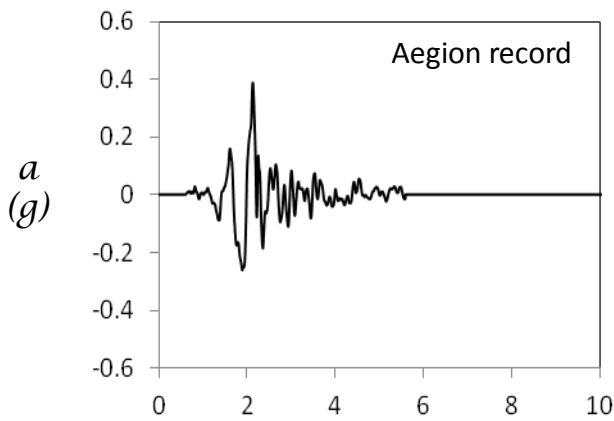

Figure B61. Acceleration time histories measured on the retrofitted building with rocking isolation ($b = 2.5\text{m}$, $t = 0.05\text{m}$) while submitted to the record of Aegion.

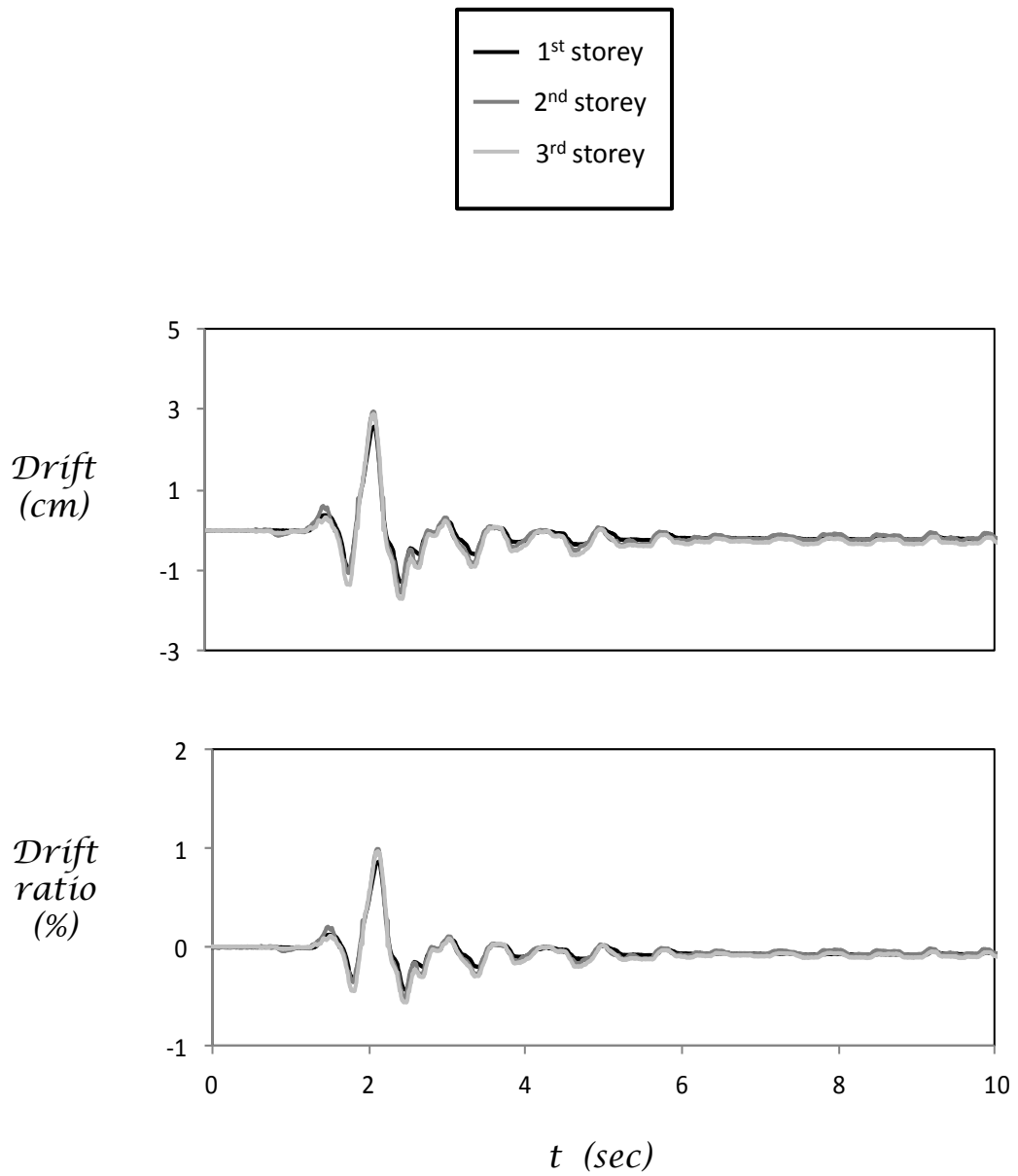

Figure B62. Time histories of storey drift and drift ratio of retrofitted building with rocking isolation ($b = 2.5\text{m}$, $t = 0.05\text{m}$) while submitted to the record of Aegion.

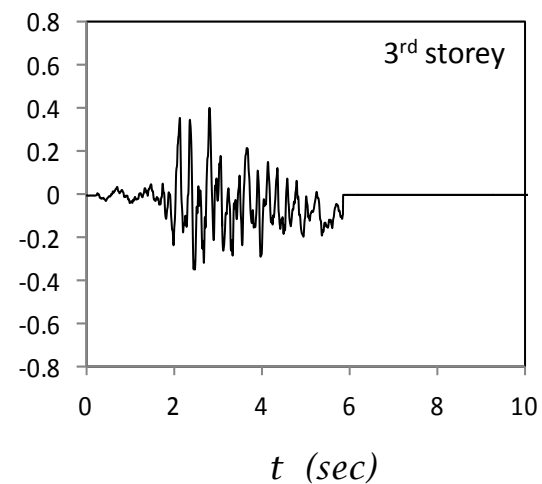
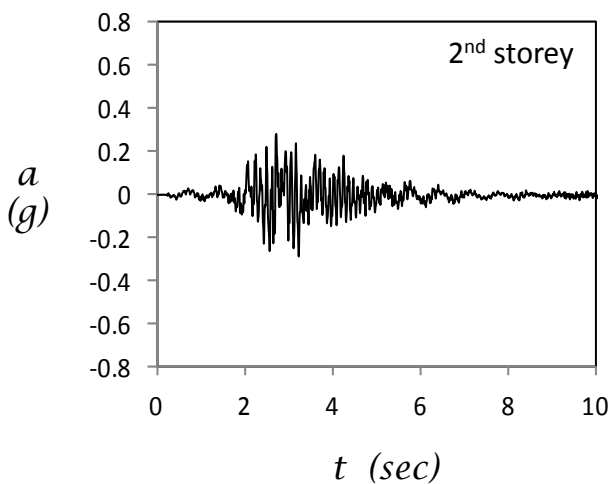
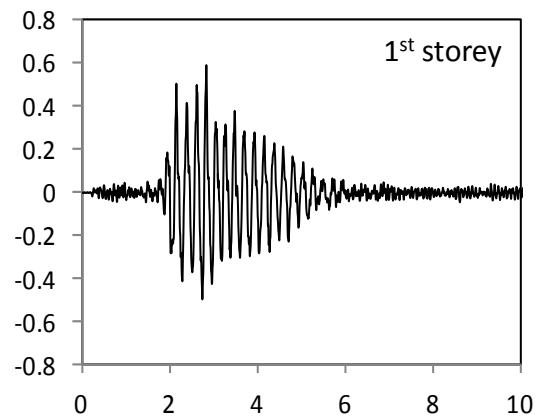
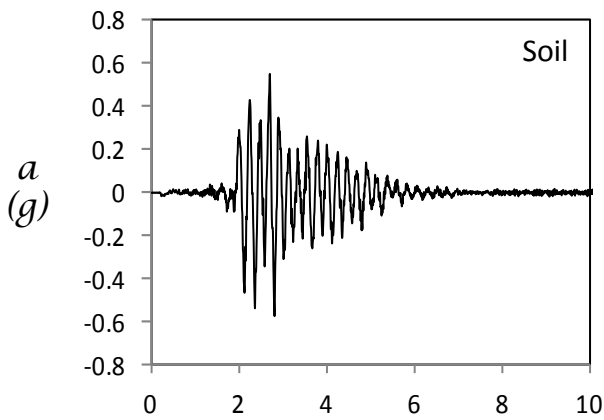
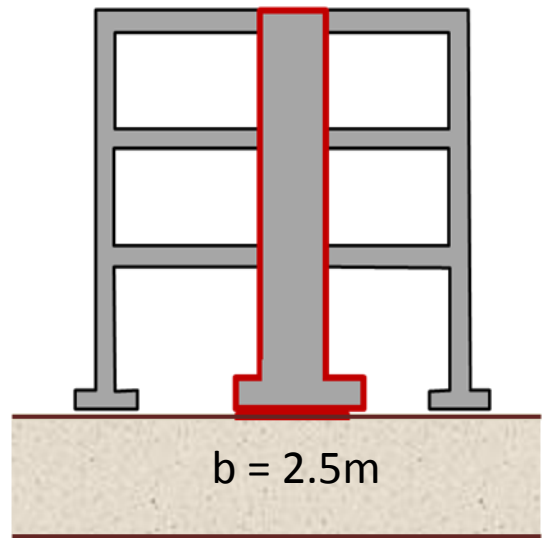
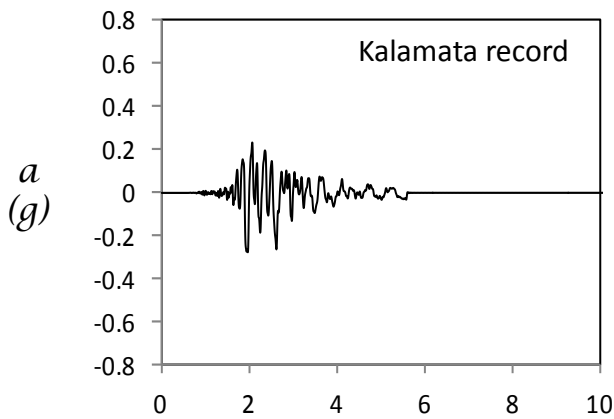

Figure B63. Acceleration time histories measured on the retrofitted building with rocking isolation ($b = 2.5\text{m}$, $t = 0.05\text{m}$) while submitted to the record of Kalamata.

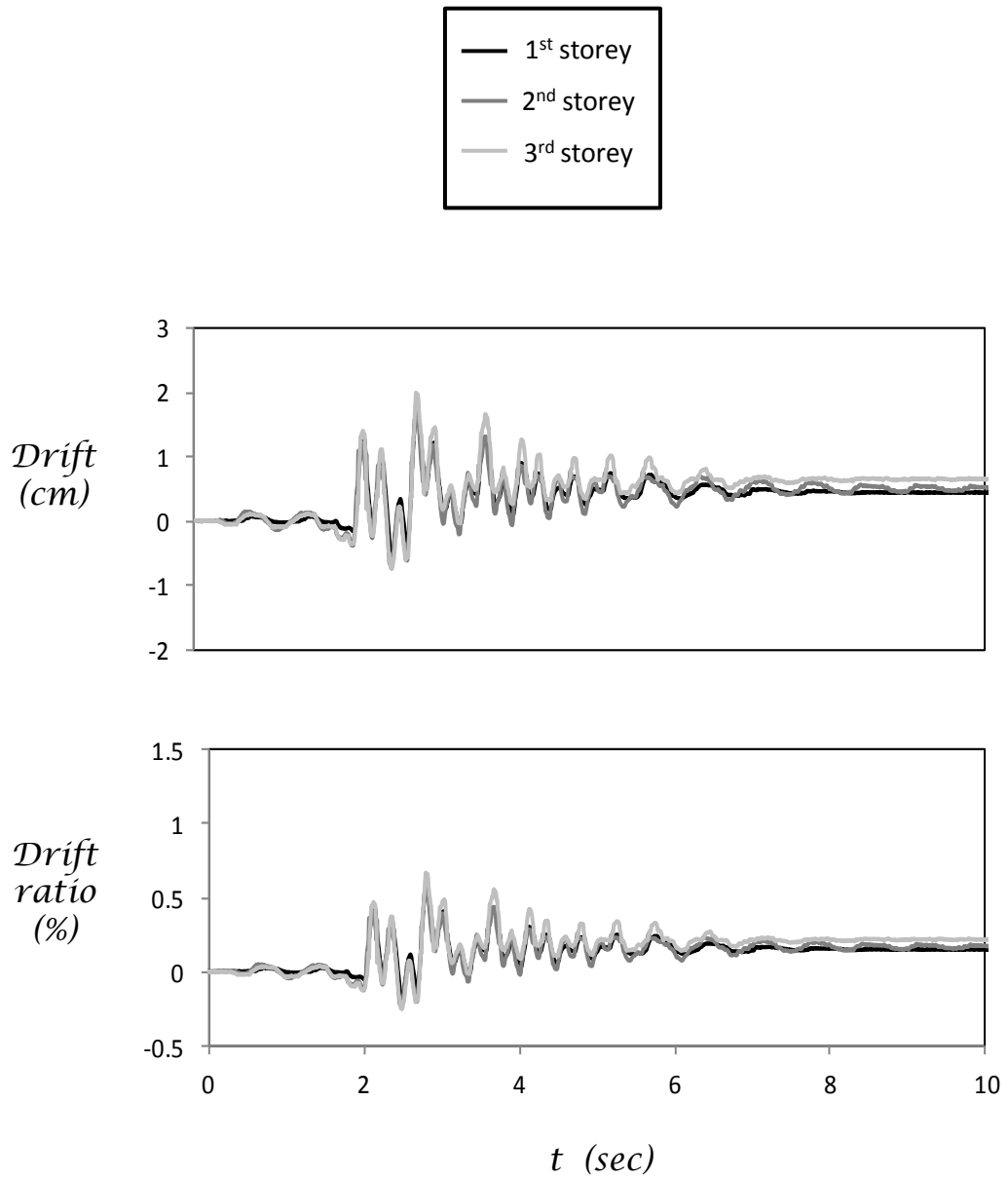

Figure B64. Time histories of storey drift and drift ratio of retrofitted building with rocking isolation ($b = 2.5\text{m}$, $t = 0.05\text{m}$) while submitted to the record of Kalamata.

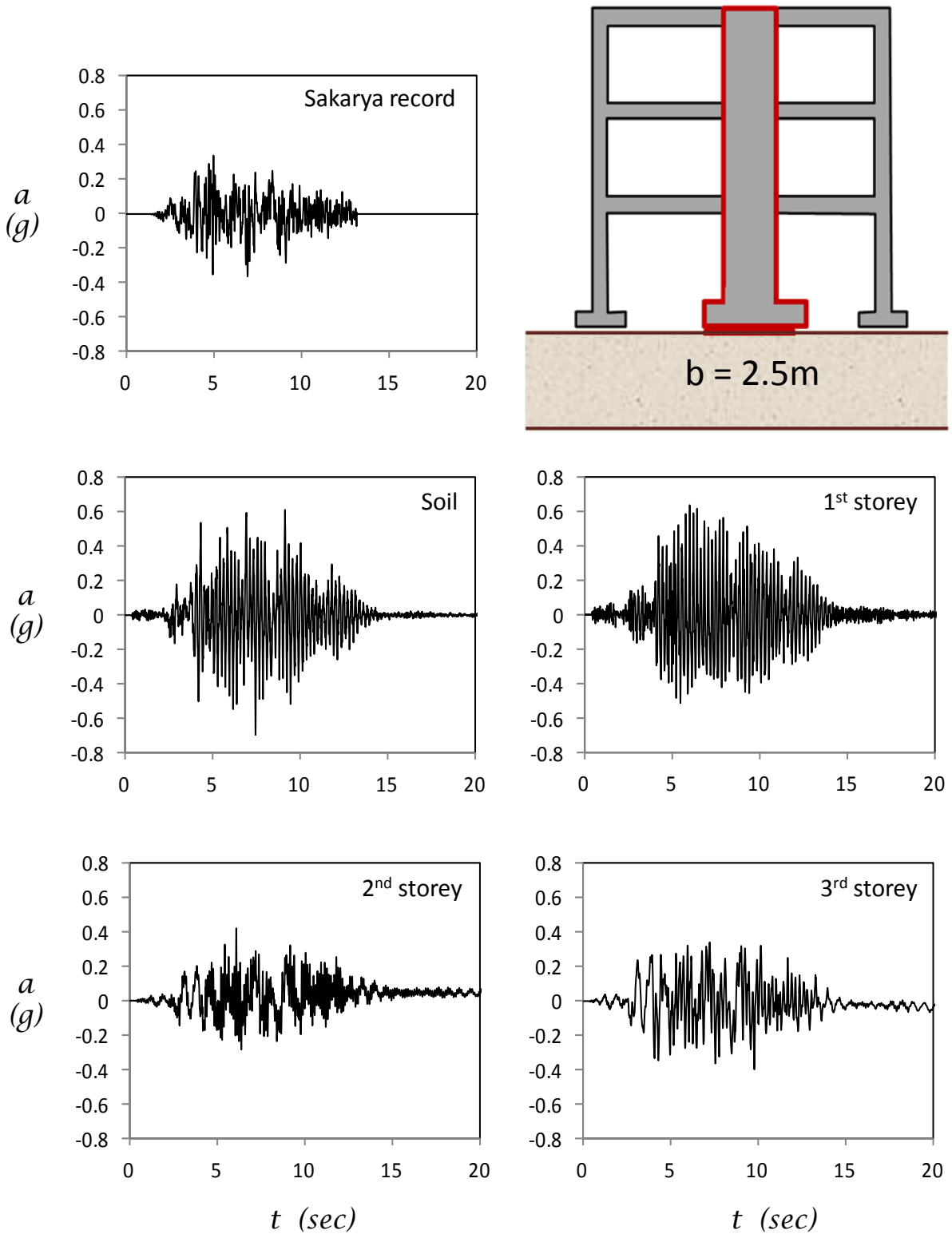

Figure B65. Acceleration time histories measured on the retrofitted building with rocking isolation ($b = 2.5\text{m}$, $t = 0.05\text{m}$) while submitted to the record of Sakarya.

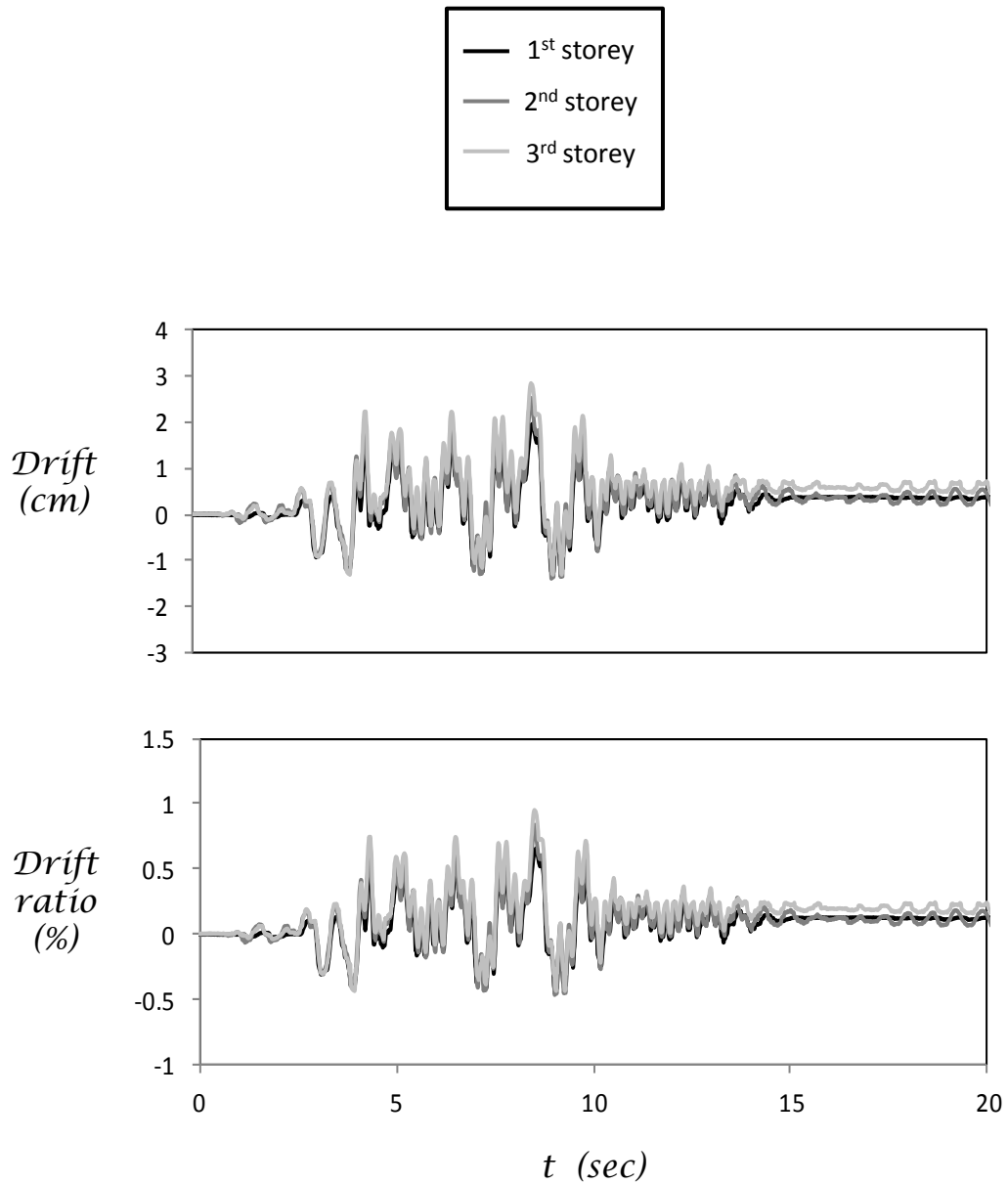

Figure B66. Time histories of storey drift and drift ratio of retrofitted building with rocking isolation ($b = 2.5\text{m}$, $t = 0.05\text{m}$) while submitted to the record of Sakarya.

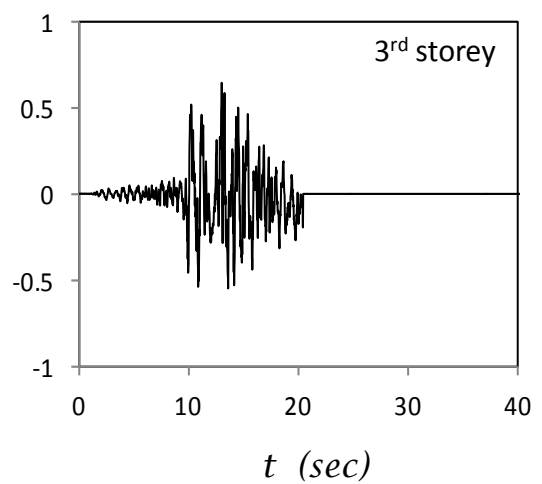
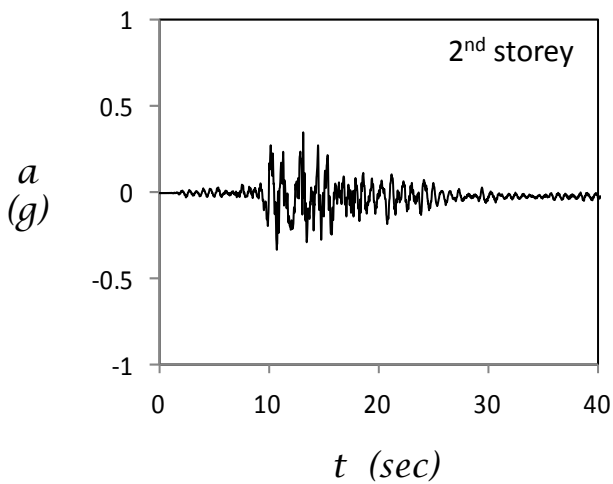
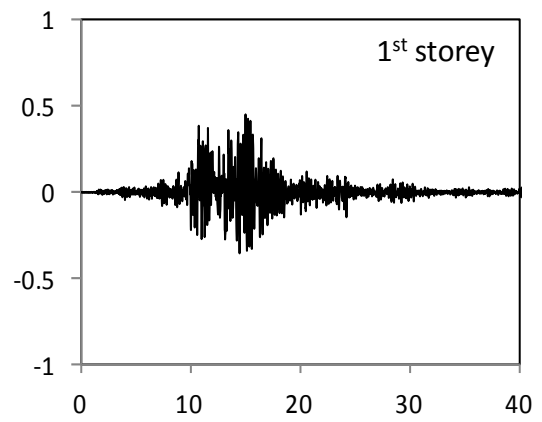
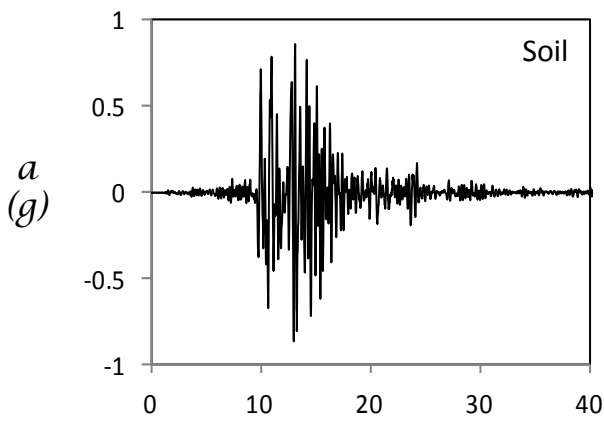
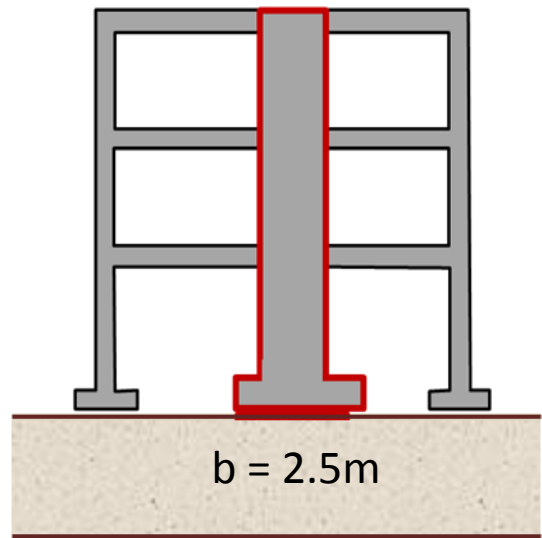
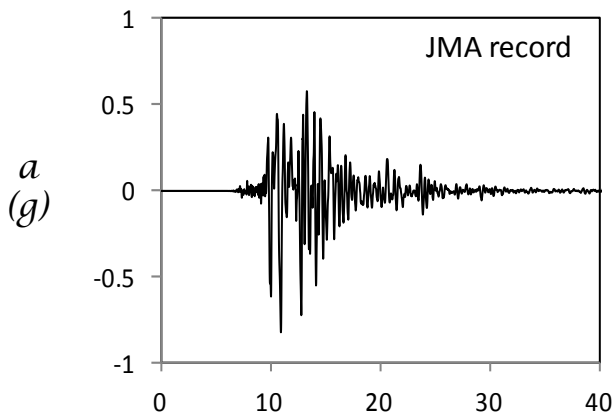

Figure B67. Acceleration time histories measured on the retrofitted building with rocking isolation ($b = 2.5\text{m}$, $t = 0.05\text{m}$) while submitted to the record of JMA.

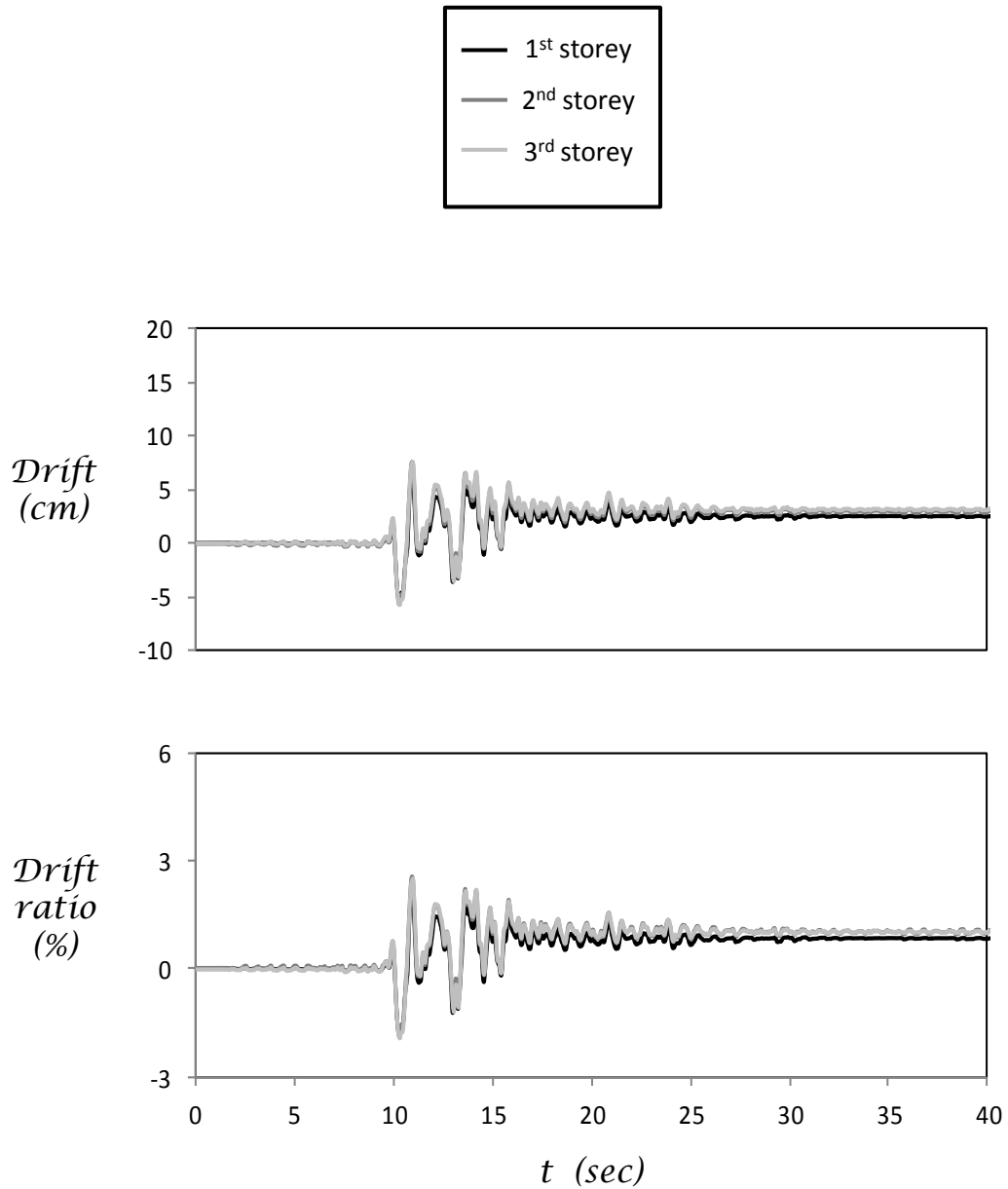

Figure B68. Time histories of storey drift and drift ratio of retrofitted building with rocking isolation ($b = 2.5\text{m}$, $t = 0.05\text{m}$) while submitted to the record of JMA.

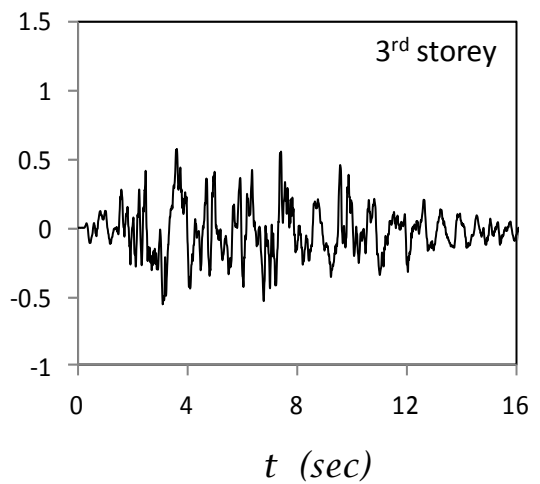
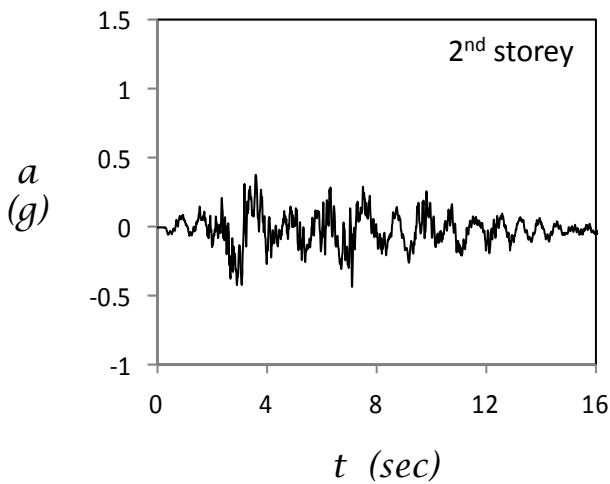
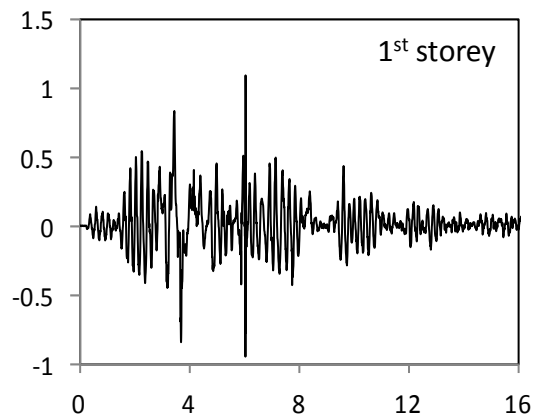
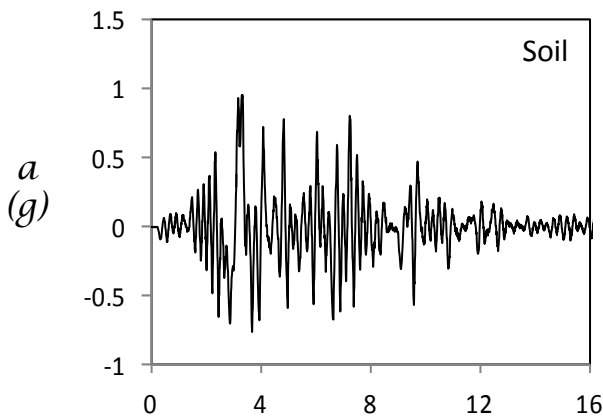
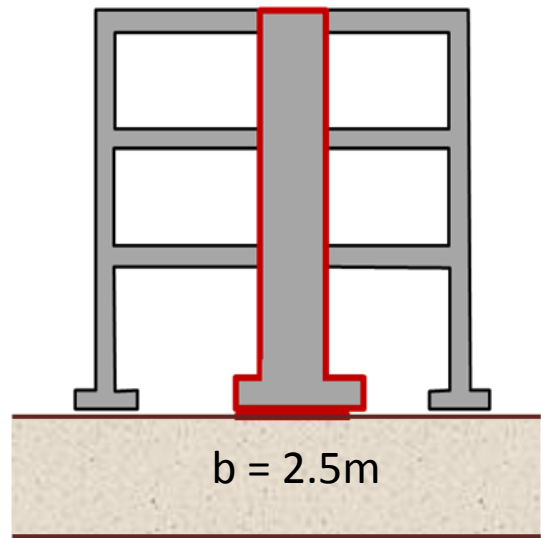
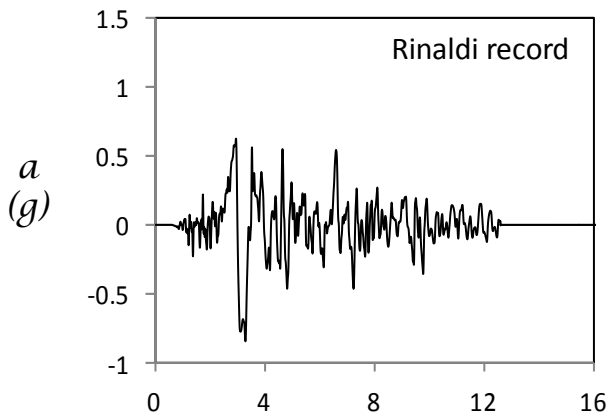

Figure B69. Acceleration time histories measured on the retrofitted building with rocking isolation ($b = 2.5\text{m}$, $t = 0.05\text{m}$) while submitted to the record of Rinaldi.

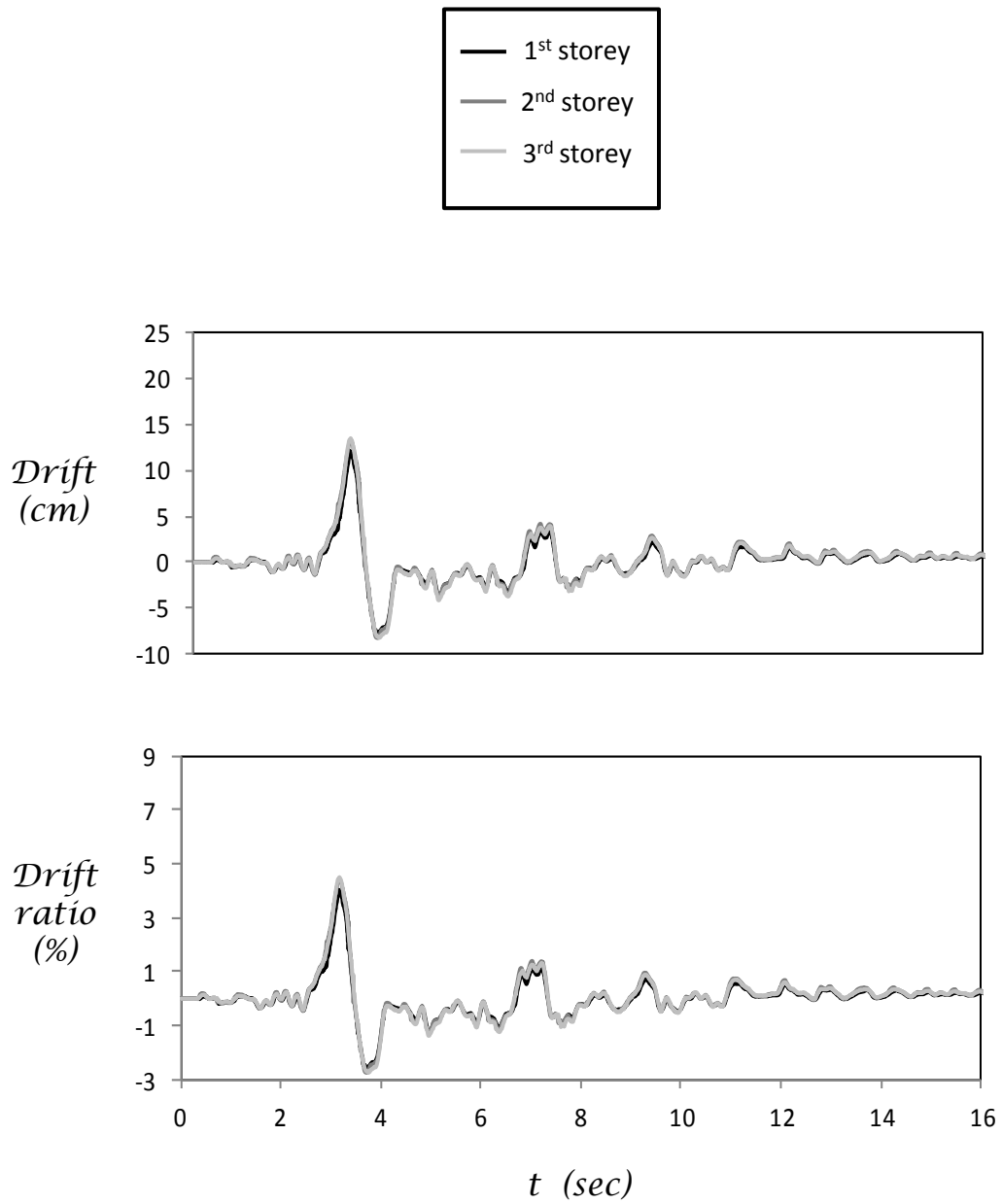

Figure B70. Time histories of storey drift and drift ratio of retrofitted building with rocking isolation ($b = 2.5\text{m}$, $t = 0.05\text{m}$) while submitted to the record of Rinaldi.

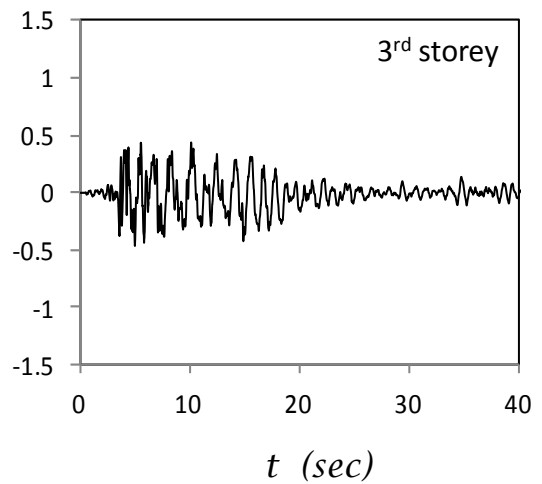
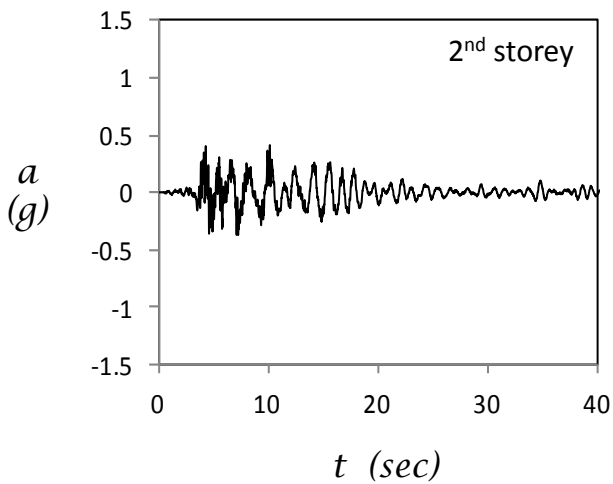
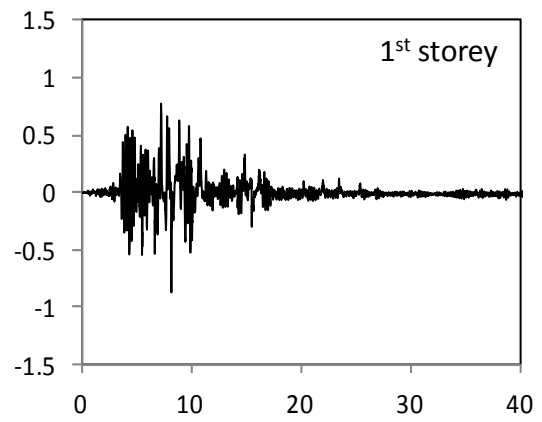
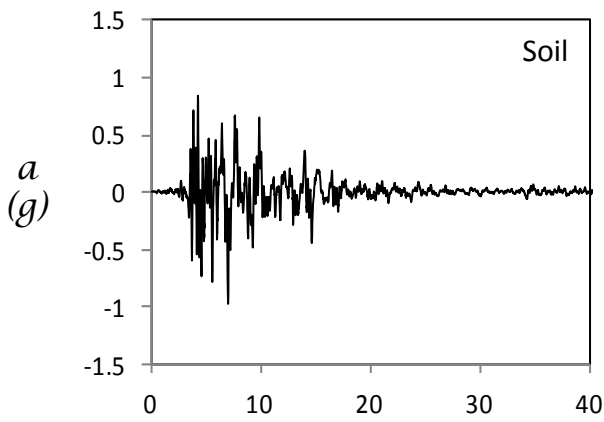
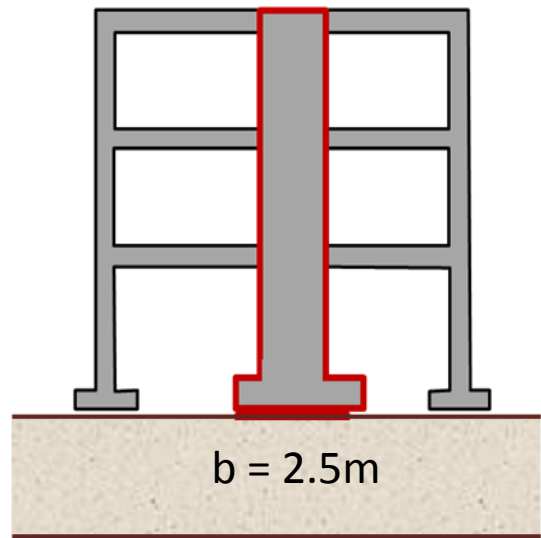
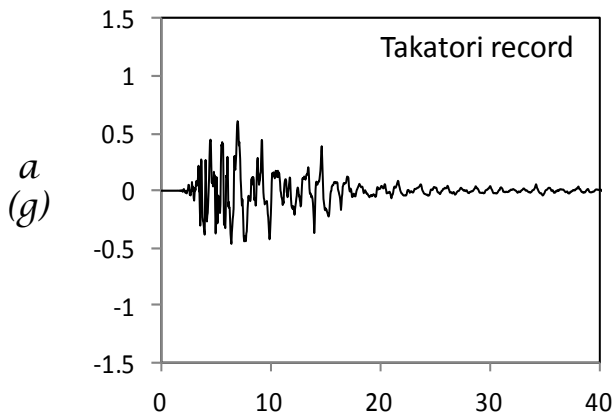

Figure B71. Acceleration time histories measured on the retrofitted building with rocking isolation ($b = 2.5\text{m}$, $t = 0.05\text{m}$) while submitted to the record of Takatori.

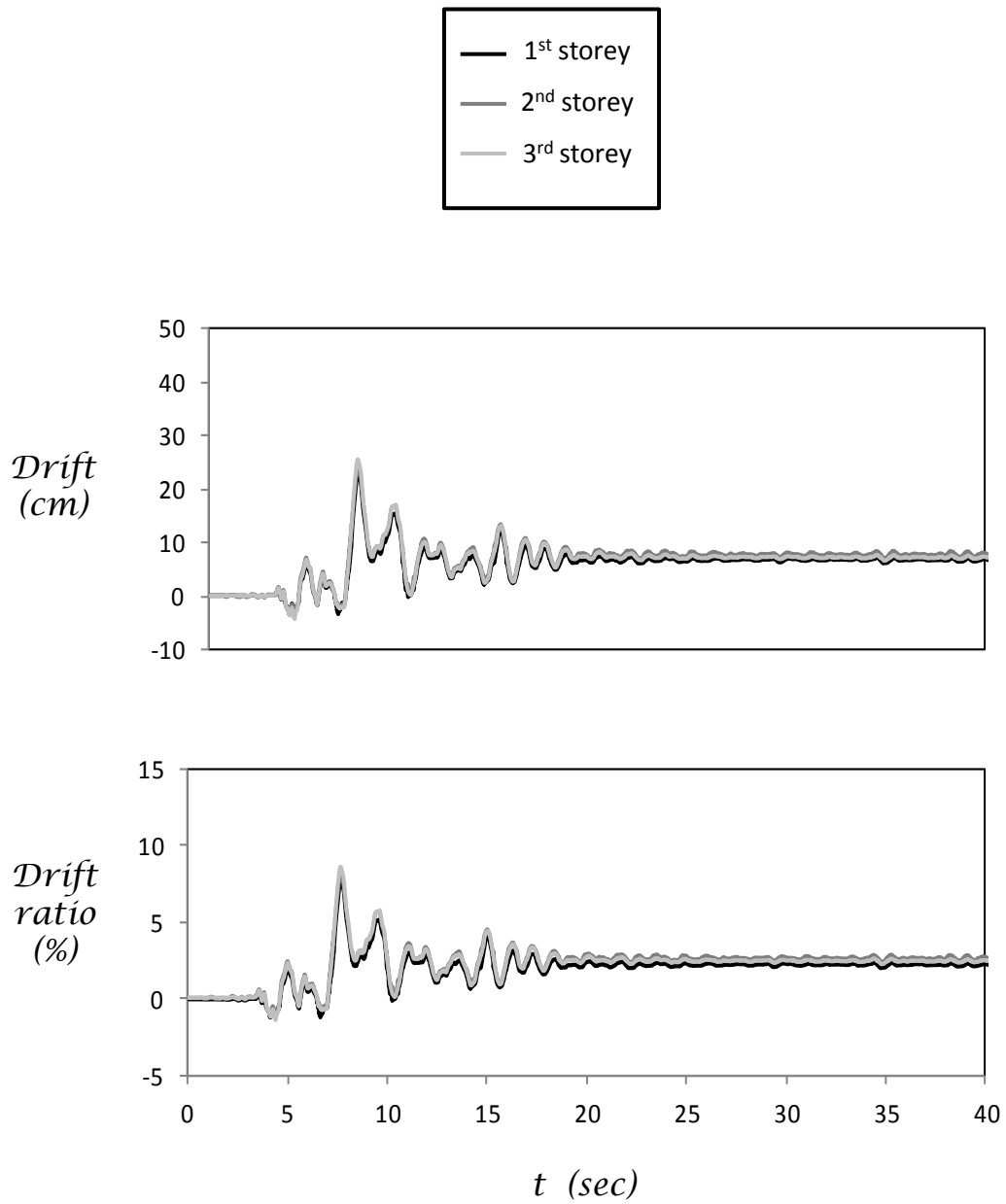

Figure B72. Time histories of storey drift and drift ratio of retrofitted building with rocking isolation ($b = 2.5\text{m}$, $t = 0.05\text{m}$) while submitted to the record of Takatori.

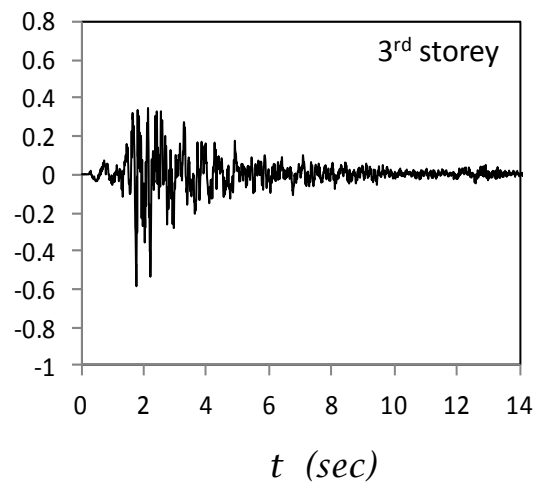
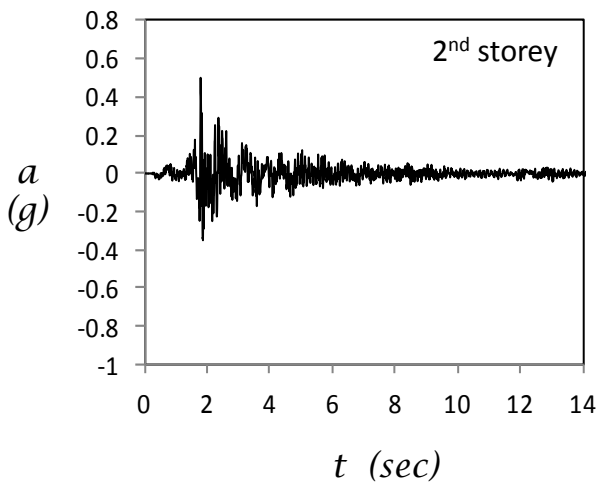
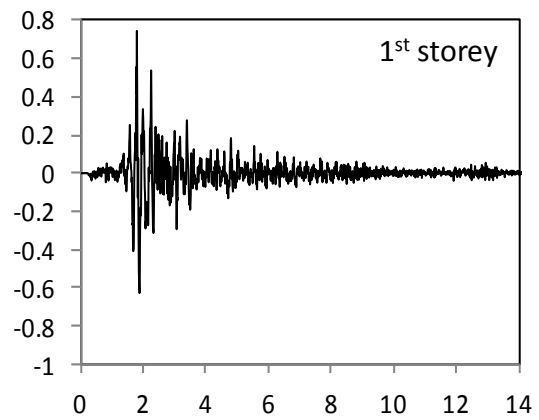
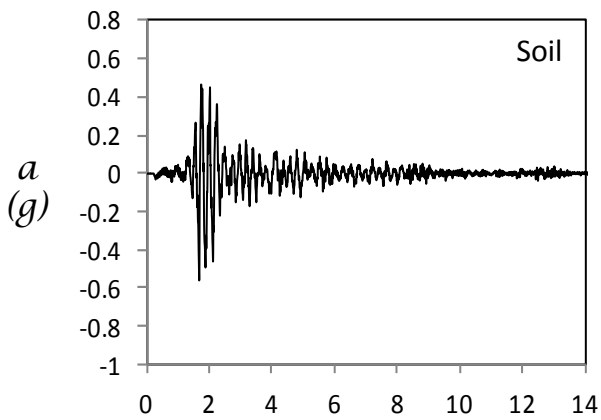
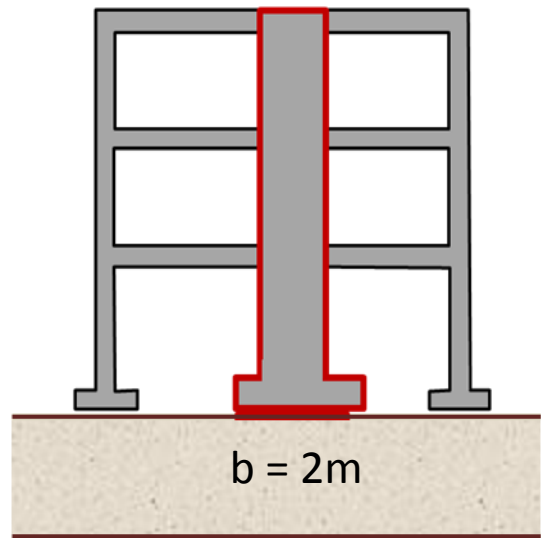
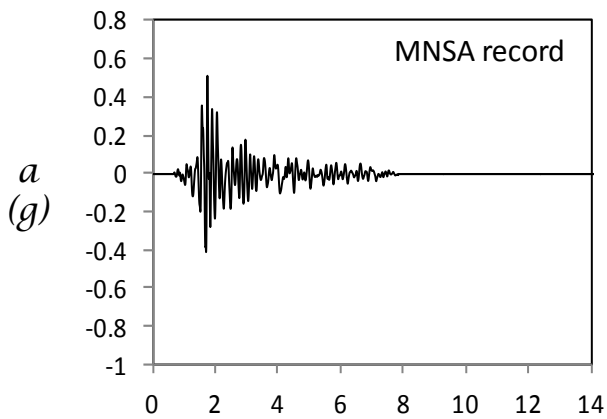

Figure B73. Acceleration time histories measured on the retrofitted building with rocking isolation ($b = 2\text{m}$, $t = 0.05\text{m}$) while submitted to the record of MNSA.

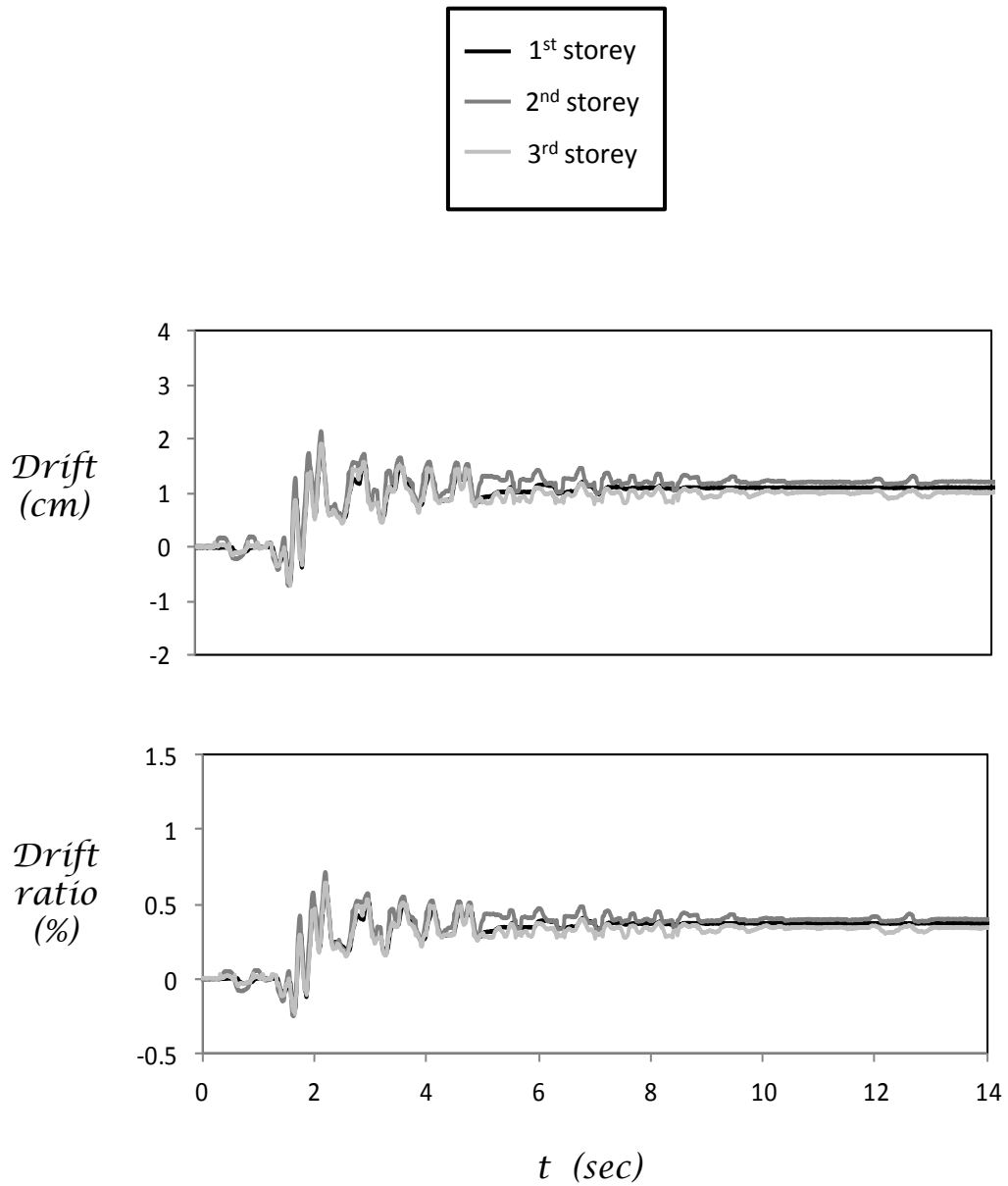
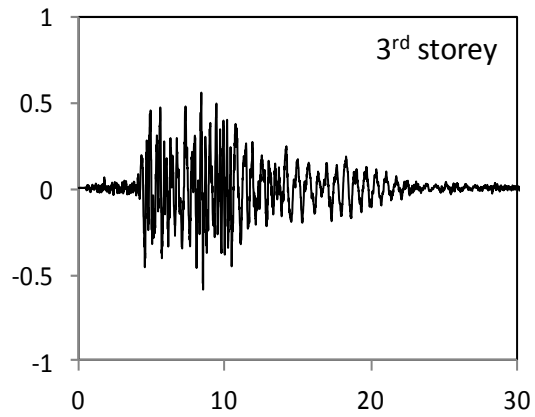
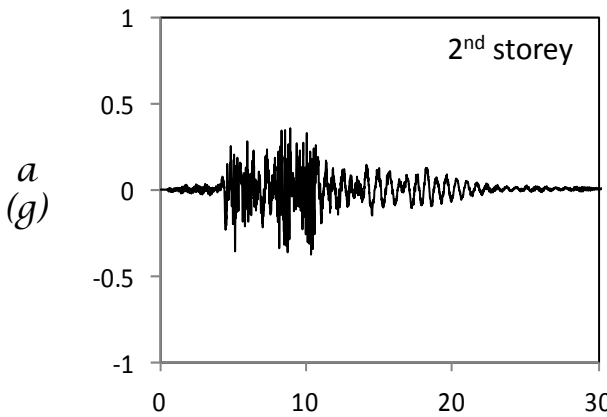
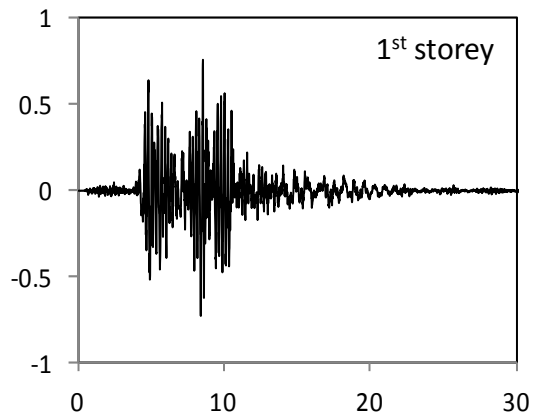
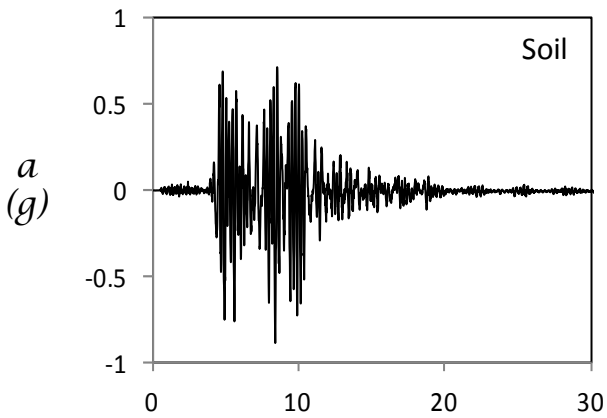
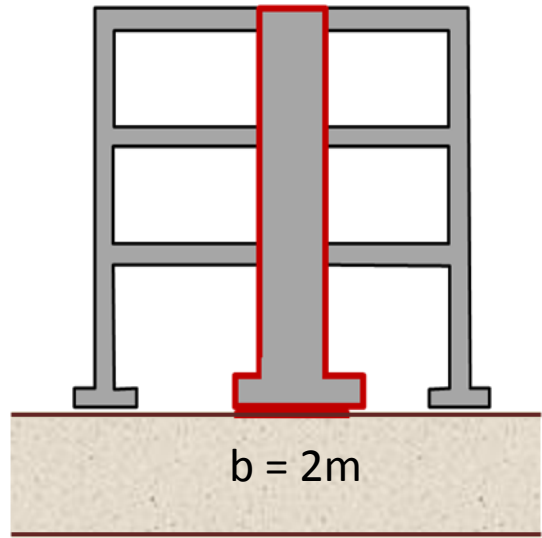
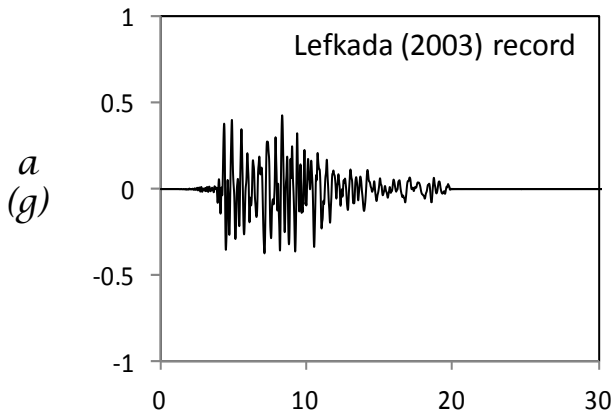

Figure B74. Time histories of storey drift and drift ratio of retrofitted building with rocking isolation ($b = 2\text{m}$, $t = 0.05\text{m}$) while submitted to the record of MNSA.



$t \text{ (sec)}$

$t \text{ (sec)}$

Figure B75. Acceleration time histories measured on the retrofitted building with rocking isolation ($b = 2\text{m}$, $t = 0.05\text{m}$) while submitted to the record of Lefkada (2003).

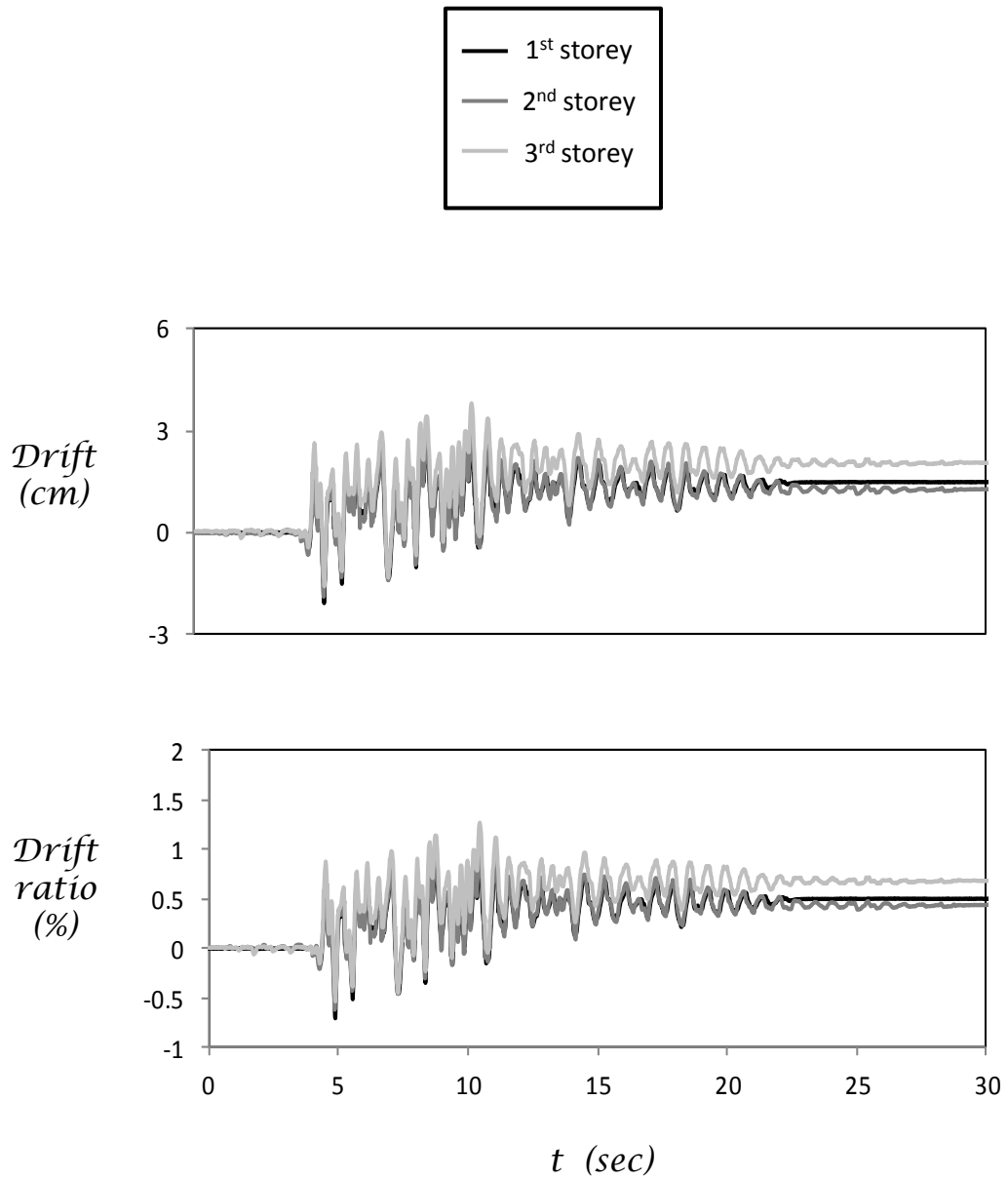

Figure B76. Time histories of storey drift and drift ratio of retrofitted building with rocking isolation ($b = 2\text{m}$, $t = 0.05\text{m}$) while submitted to the record of Lefkada (2003).

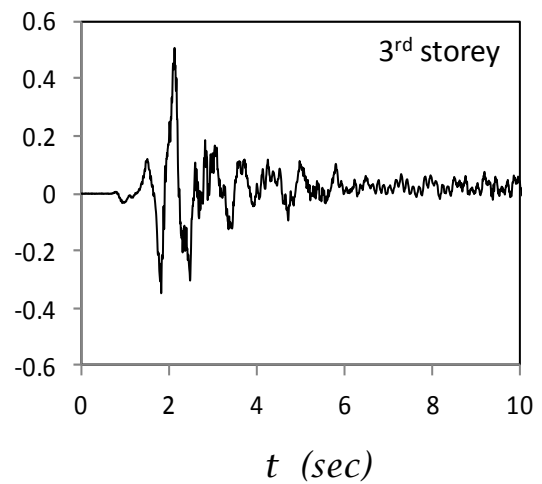
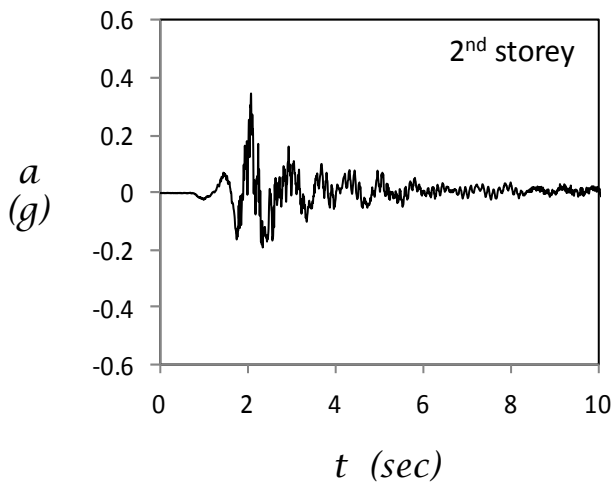
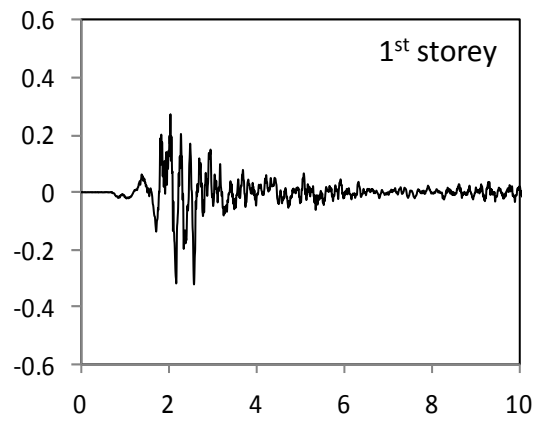
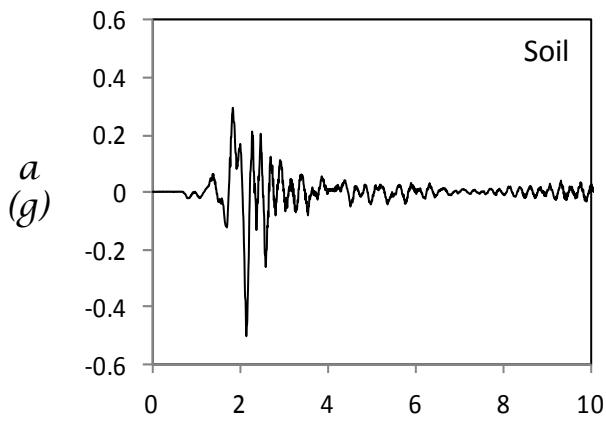
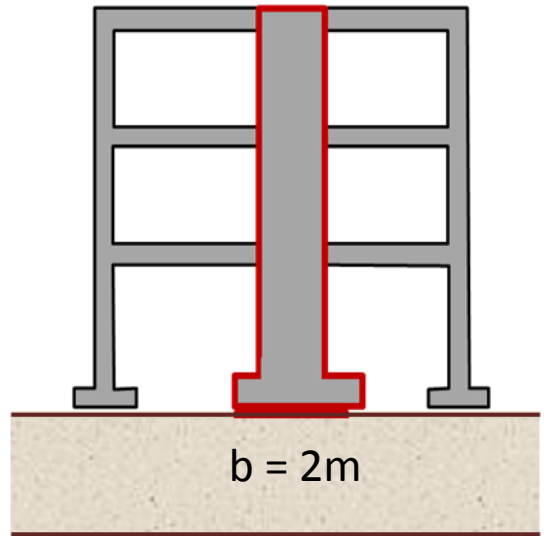
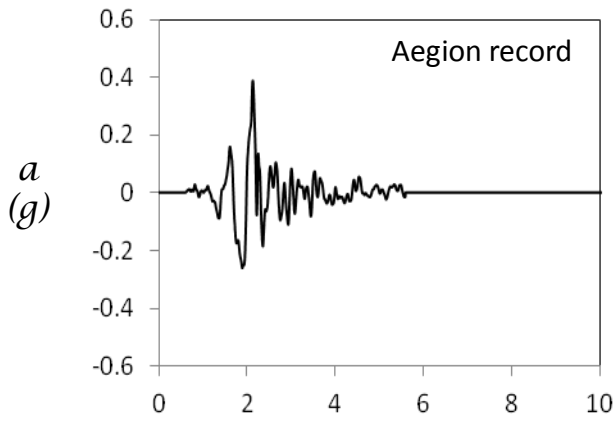

Figure B77. Acceleration time histories measured on the retrofitted building with rocking isolation ($b = 2\text{m}$, $t = 0.05\text{m}$) while submitted to the record of Aegion.

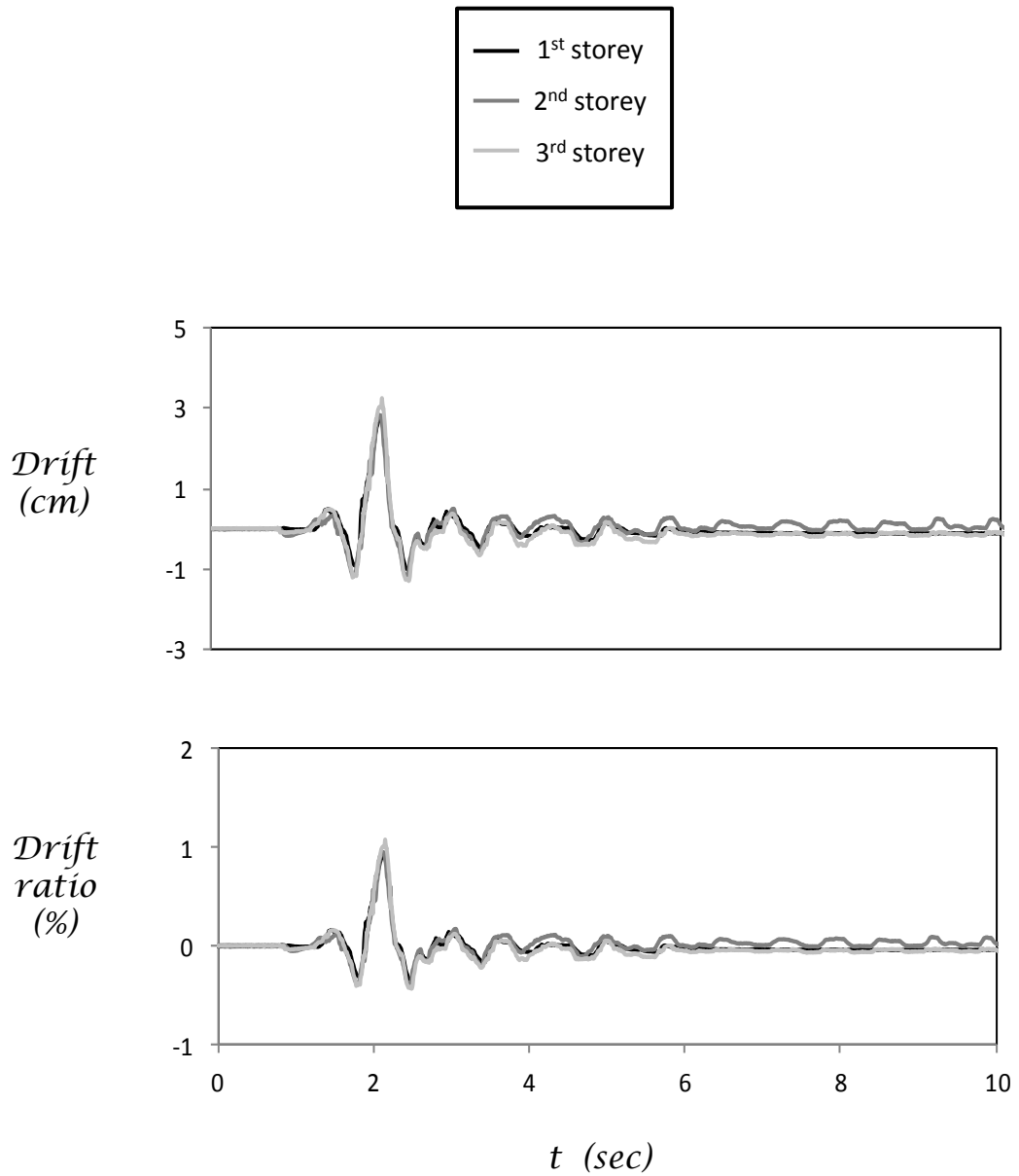
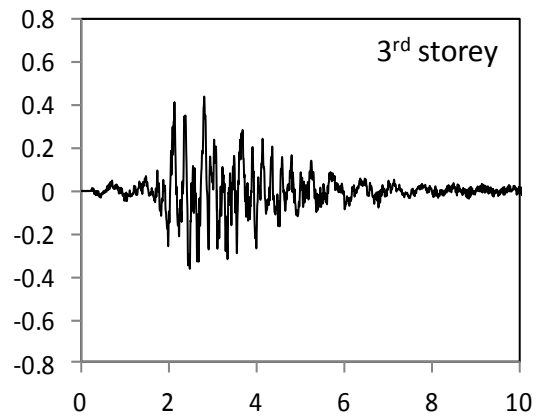
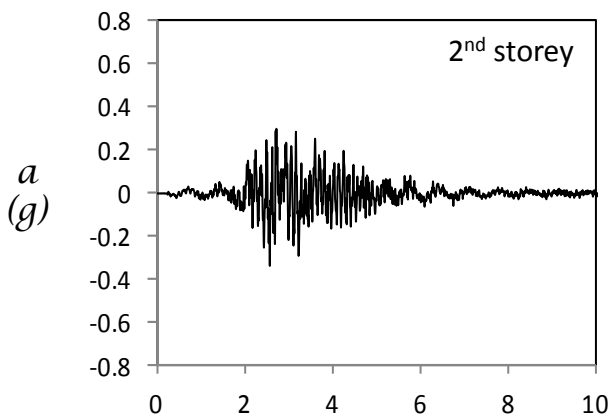
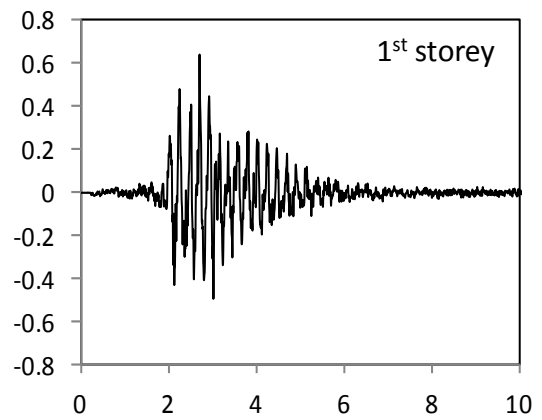
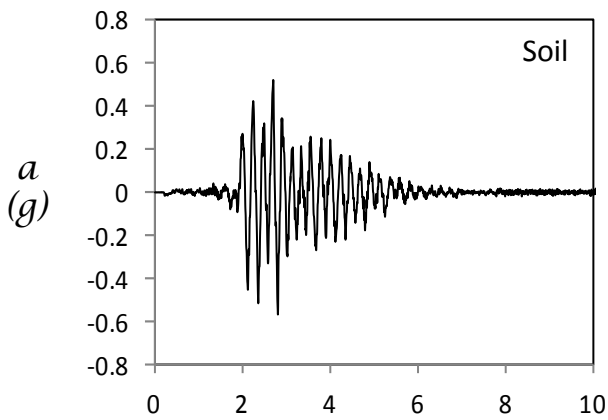
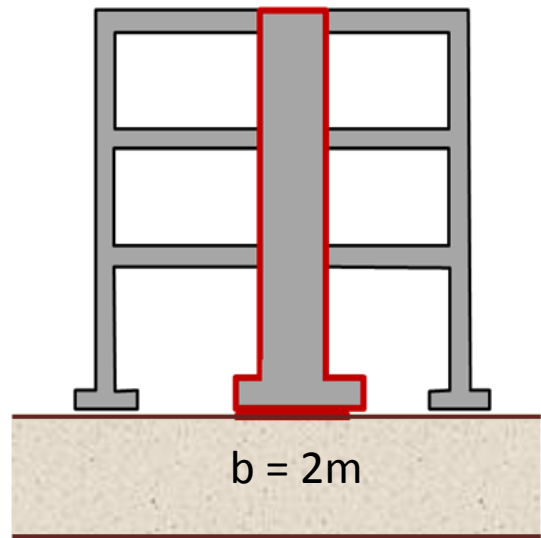
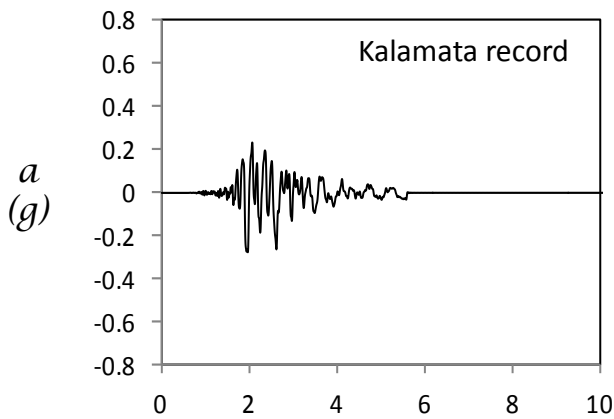

Figure B78. Time histories of storey drift and drift ratio of retrofitted building with rocking isolation ($b = 2\text{m}$, $t = 0.05\text{m}$) while submitted to the record of Aegion.



t (sec)

t (sec)

Figure B79. Acceleration time histories measured on the retrofitted building with rocking isolation ($b = 2\text{m}$, $t = 0.05\text{m}$) while submitted to the record of Kalamata.

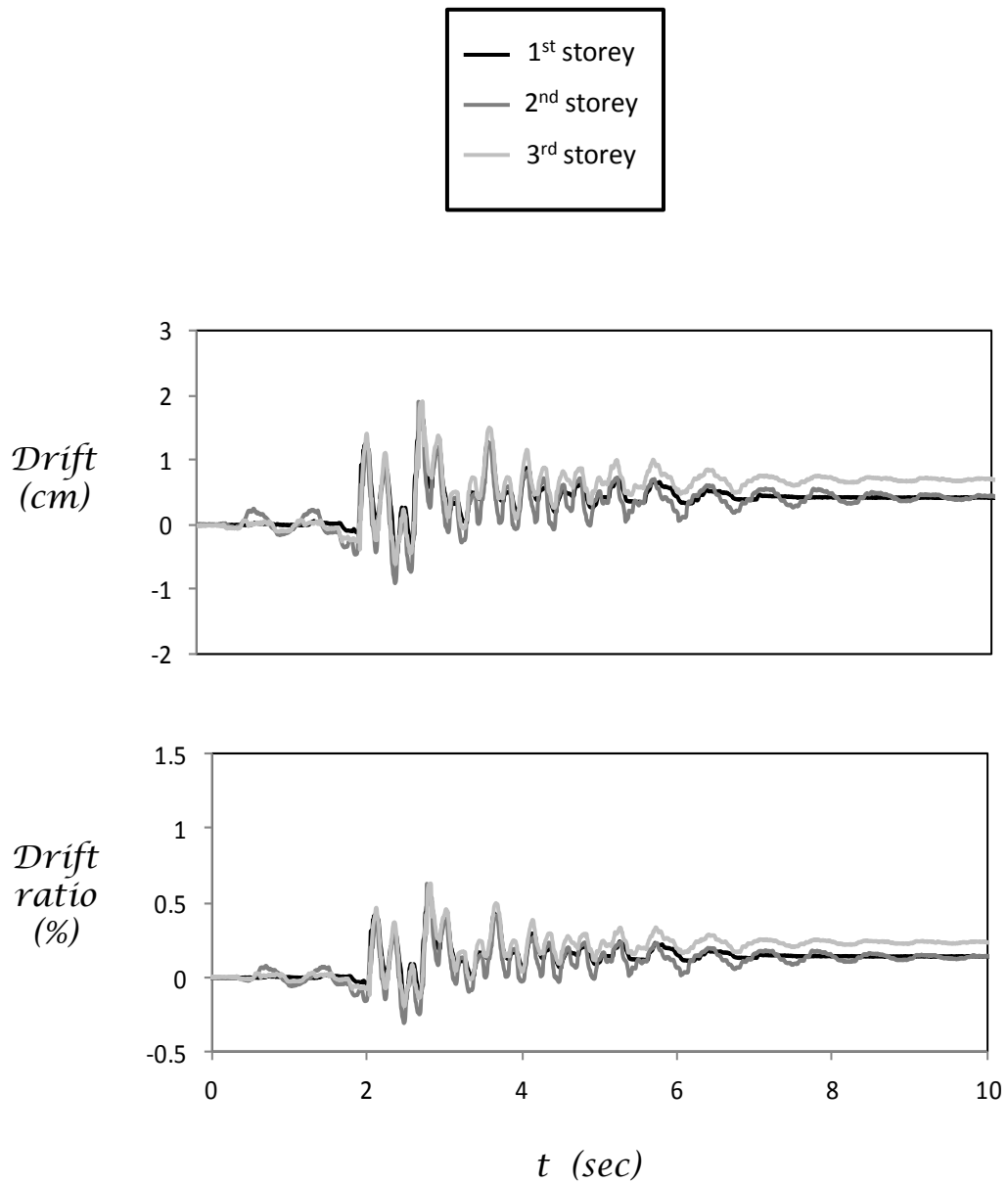

Figure B80. Time histories of storey drift and drift ratio of retrofitted building with rocking isolation ($b = 2\text{m}$, $t = 0.05\text{m}$) while submitted to the record of Kalamata.

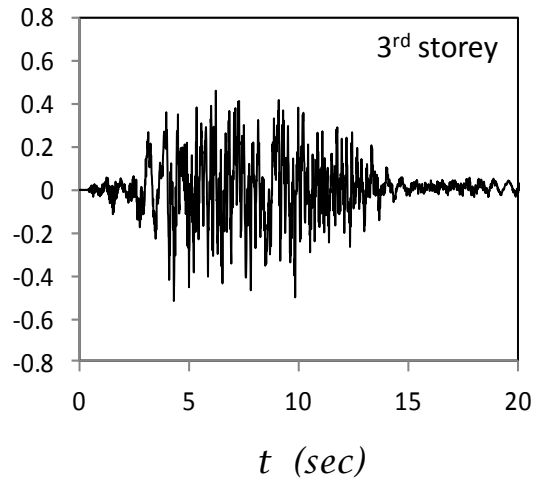
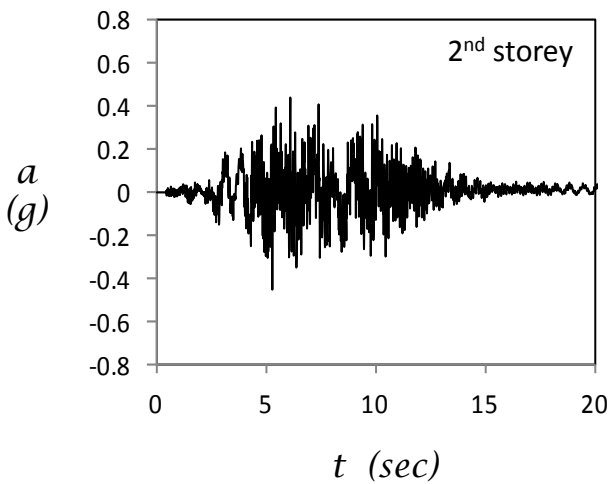
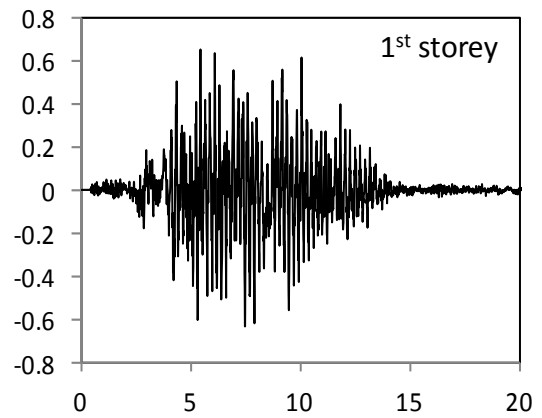
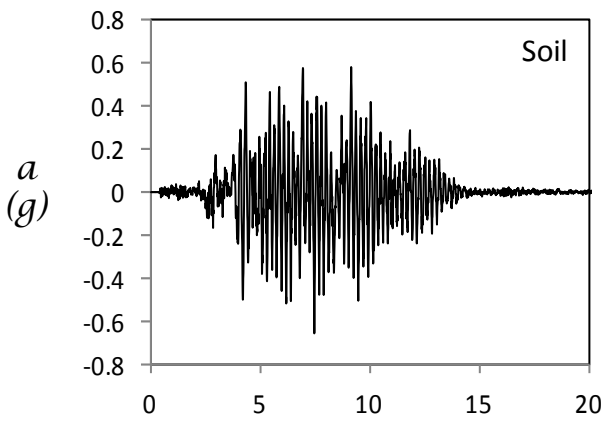
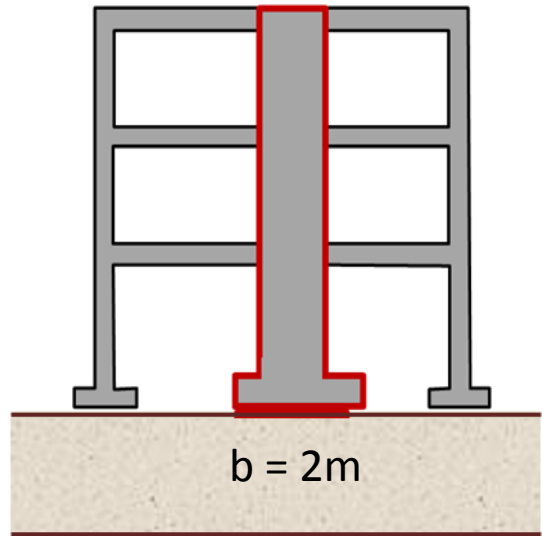
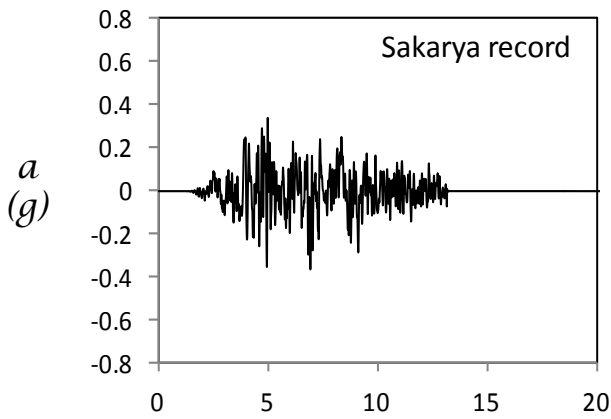

Figure B81. Acceleration time histories measured on the retrofitted building with rocking isolation ($b = 2\text{m}$, $t = 0.05\text{m}$) while submitted to the record of Sakarya.

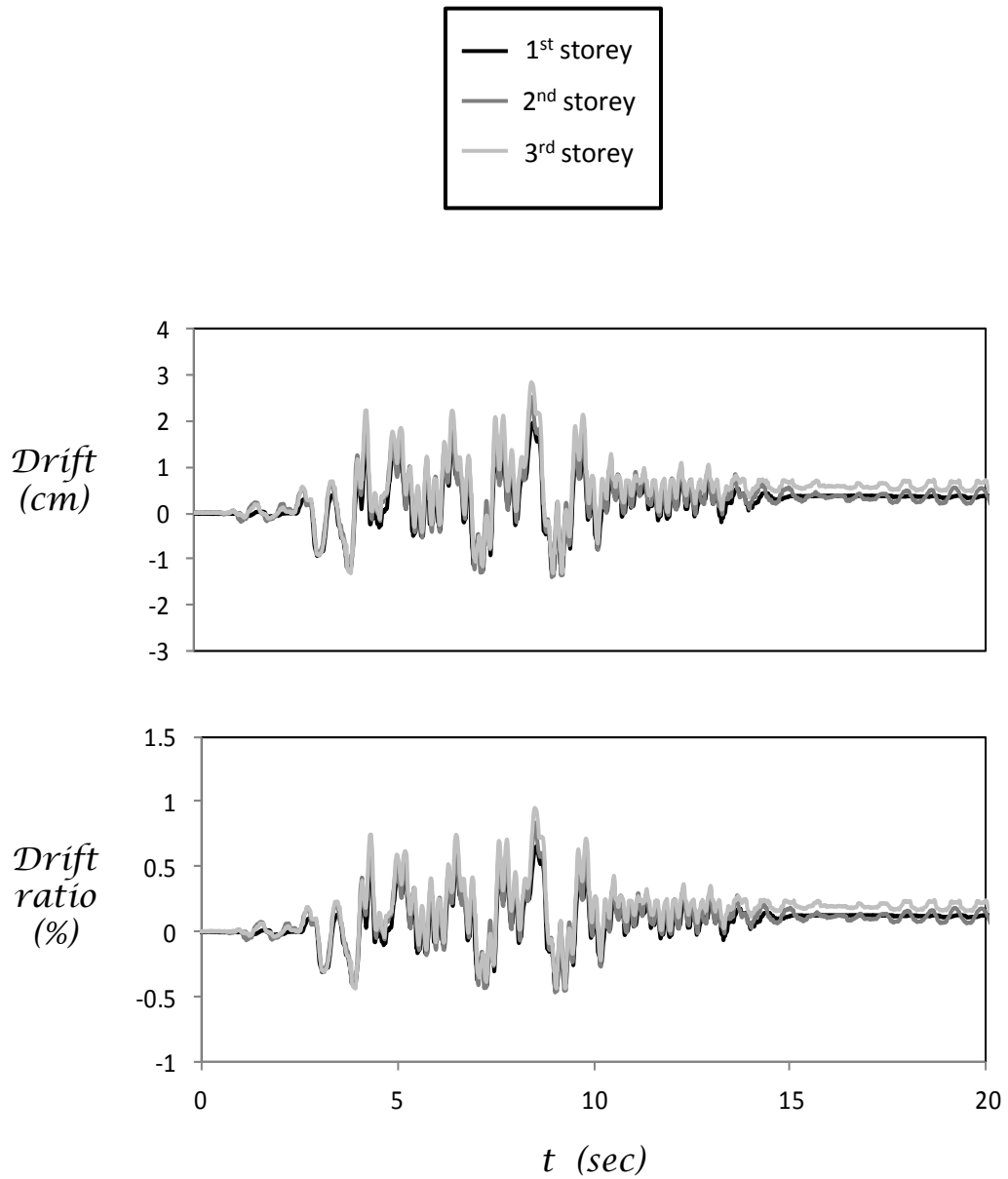

Figure B82. Time histories of storey drift and drift ratio of retrofitted building with rocking isolation ($b = 2\text{m}$, $t = 0.05\text{m}$) while submitted to the record of Sakarya.

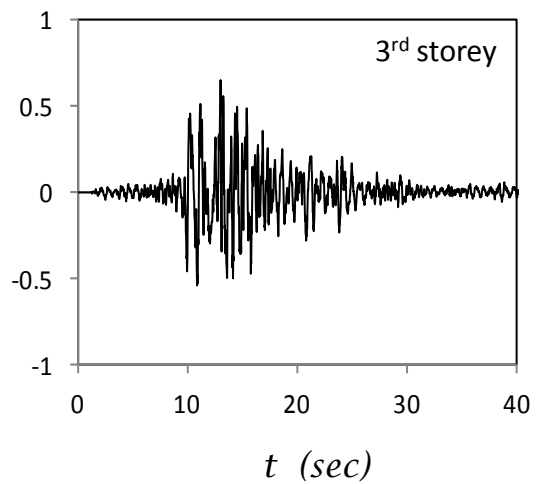
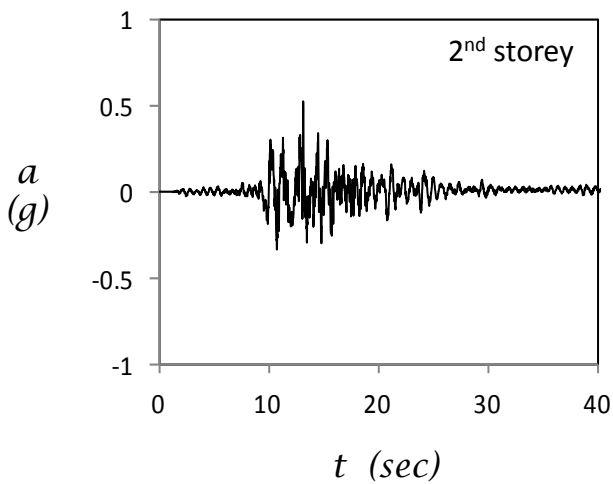
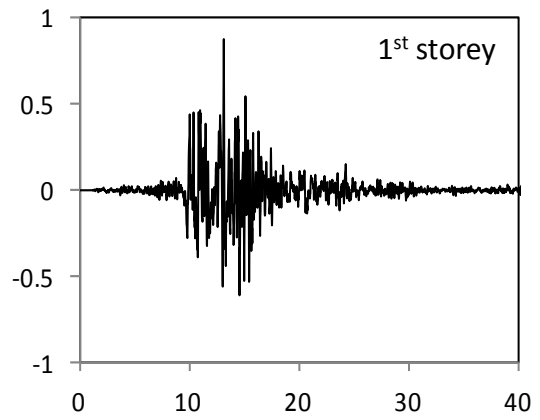
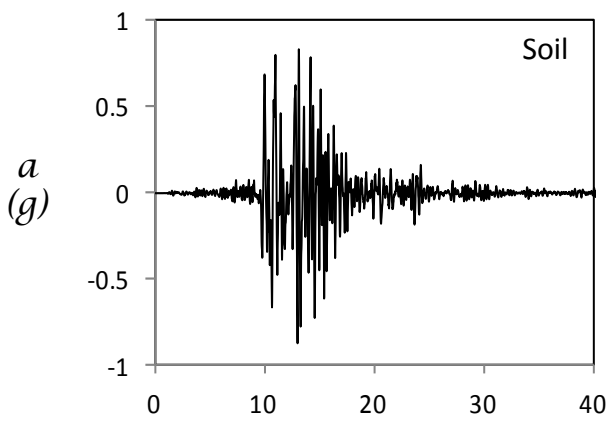
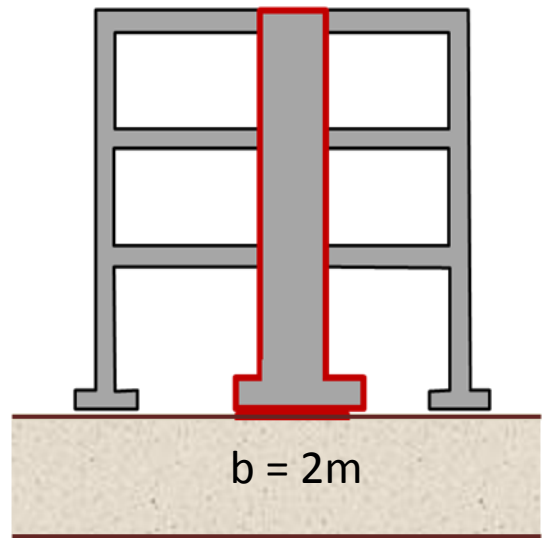
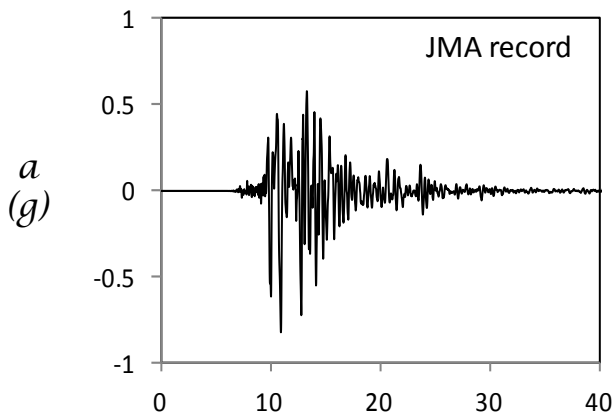

Figure B83. Acceleration time histories measured on the retrofitted building with rocking isolation ($b = 2\text{m}$, $t = 0.05\text{m}$) while submitted to the record of JMA.

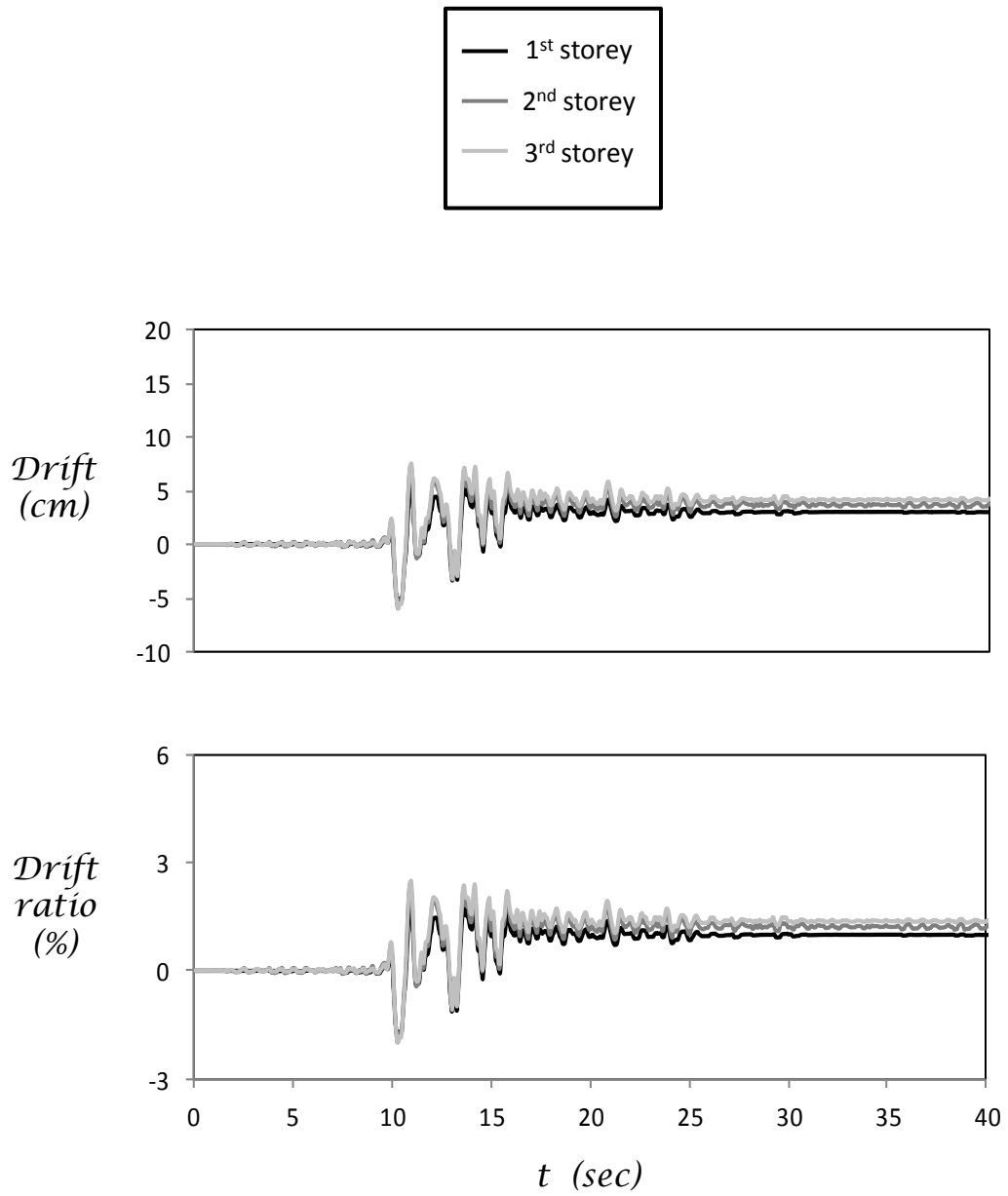

Figure B84. Time histories of storey drift and drift ratio of retrofitted building with rocking isolation ($b = 2\text{m}$, $t = 0.05\text{m}$) while submitted to the record of JMA.

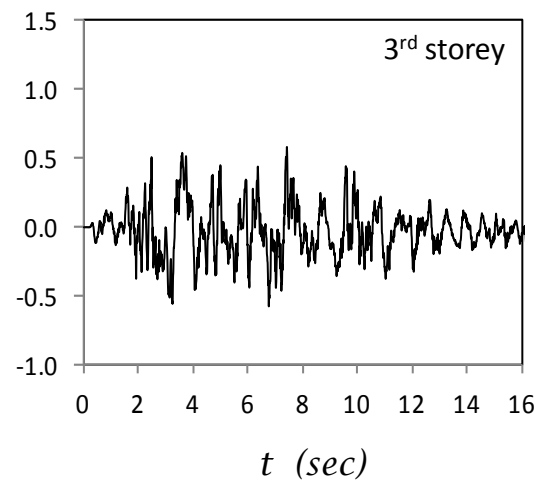
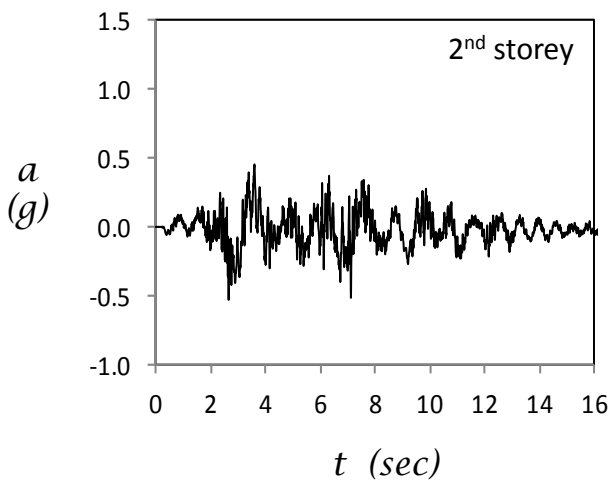
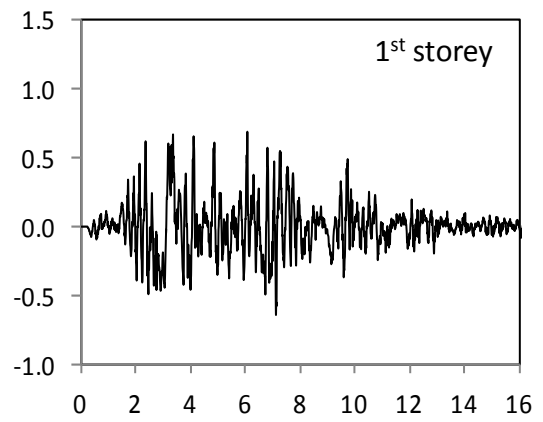
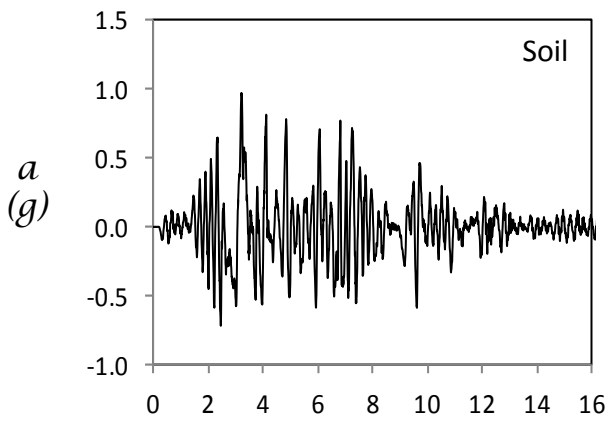
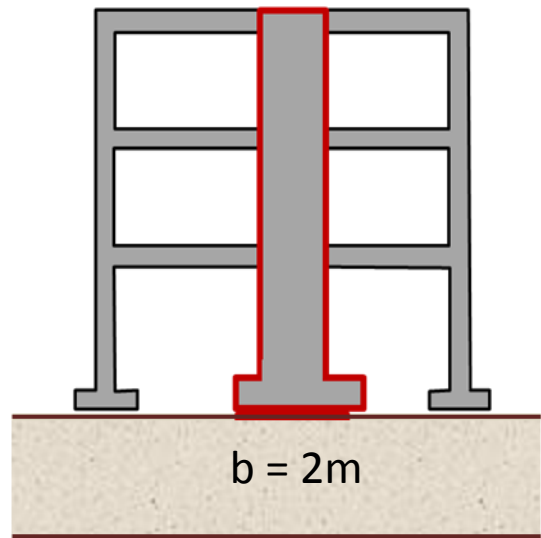
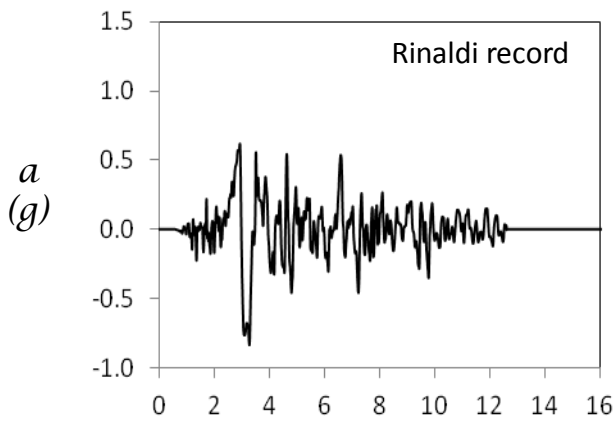

Figure B85. Acceleration time histories measured on the retrofitted building with rocking isolation ($b = 2\text{m}$, $t = 0.05\text{m}$) while submitted to the record of Rinaldi.

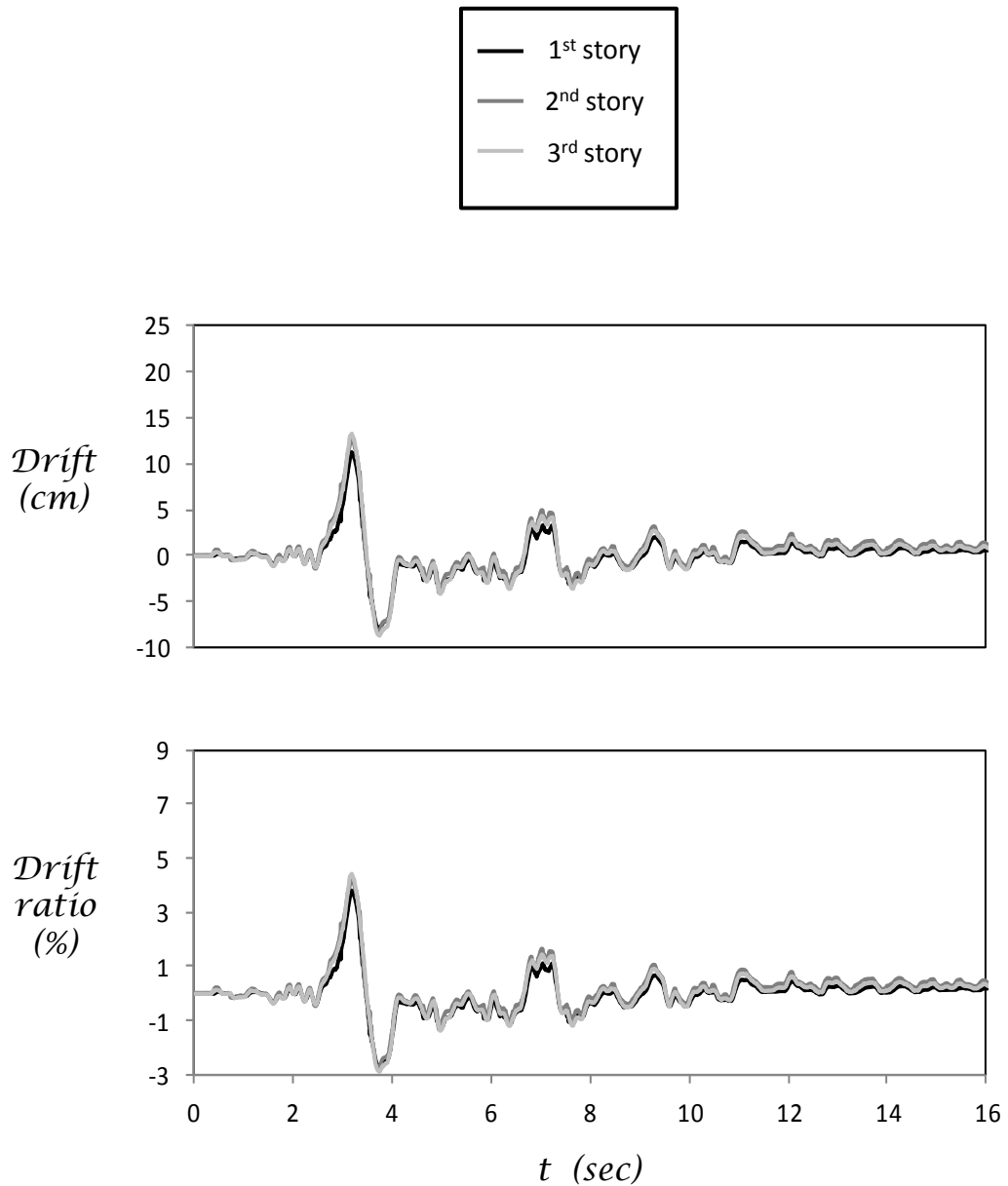

Figure B86. Time histories of storey drift and drift ratio of retrofitted building with rocking isolation ($b = 2\text{m}$, $t = 0.05\text{m}$) while submitted to the record of Rinaldi.

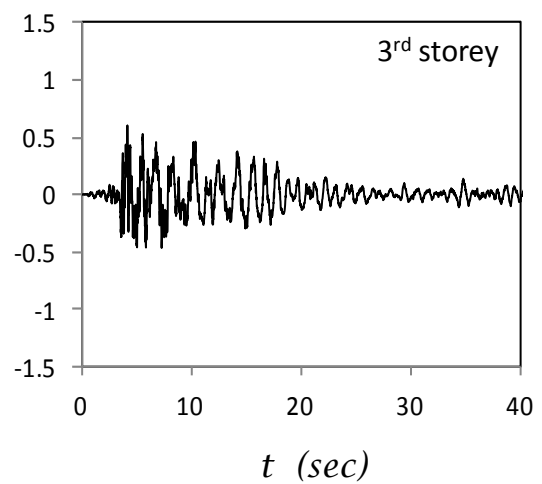
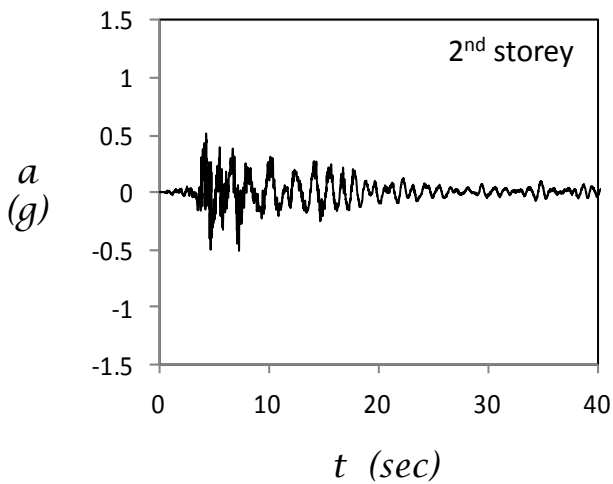
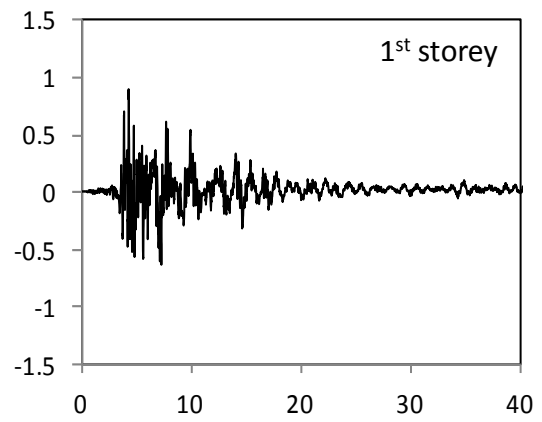
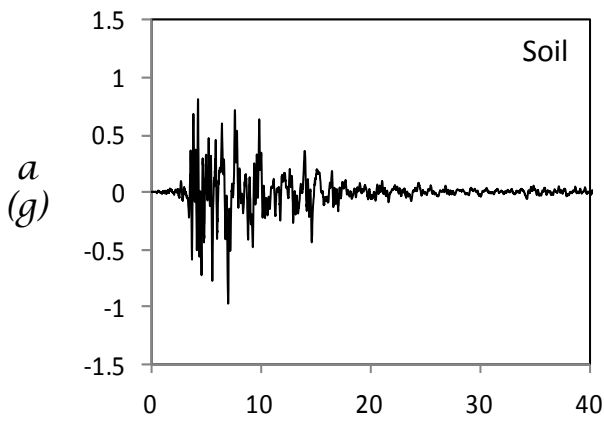
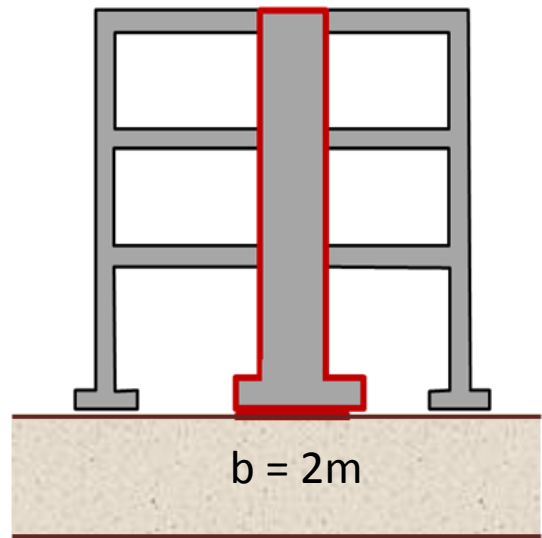
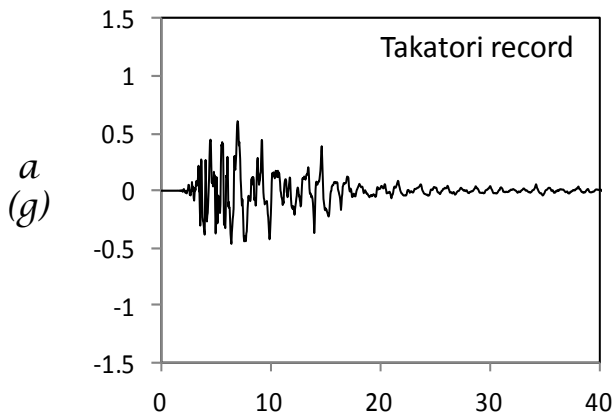

Figure B87. Acceleration time histories measured on the retrofitted building with rocking isolation ($b = 2\text{m}$, $t = 0.05\text{m}$) while submitted to the record of Takatori.

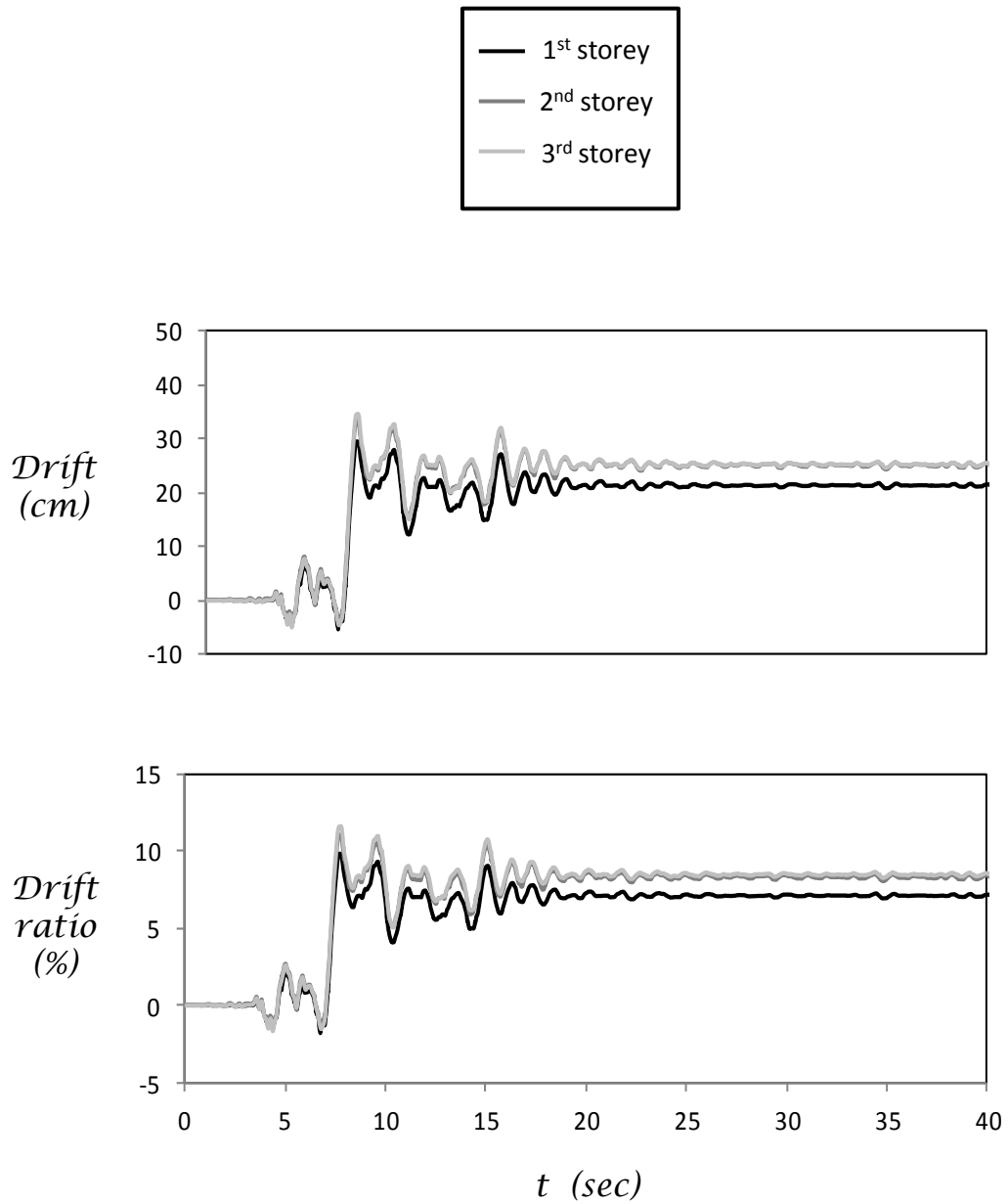
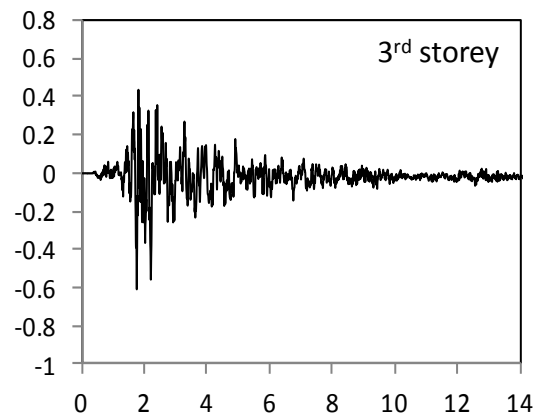
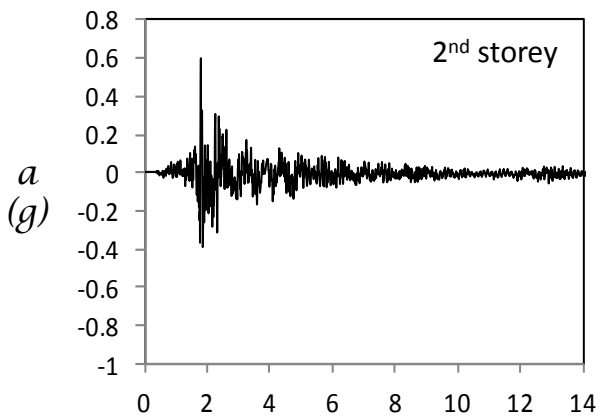
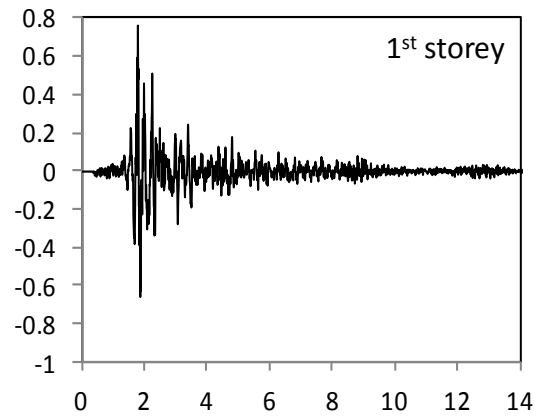
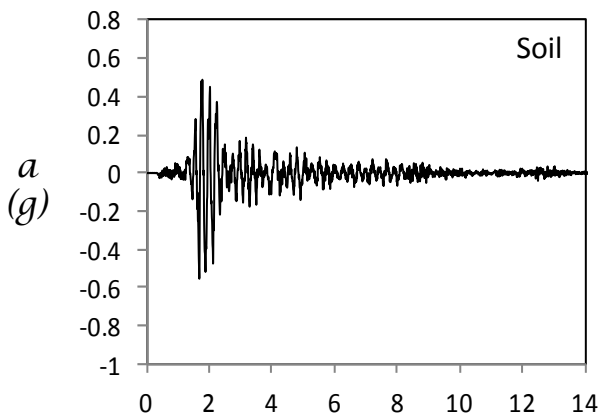
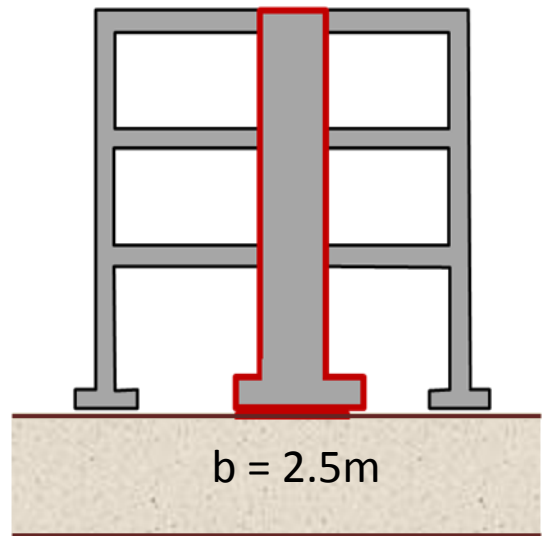
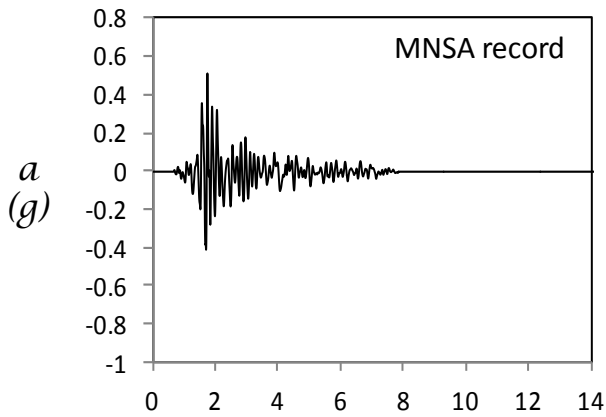

Figure B88. Time histories of storey drift and drift ratio of retrofitted building with rocking isolation ($b = 2\text{m}$, $t = 0.05\text{m}$) while submitted to the record of Takatori.



t (sec)

t (sec)

Figure B89. Acceleration time histories measured on the retrofitted building with rocking isolation ($b = 2.5\text{m}$, $t = 0.10\text{m}$) while submitted to the record of MNSA.

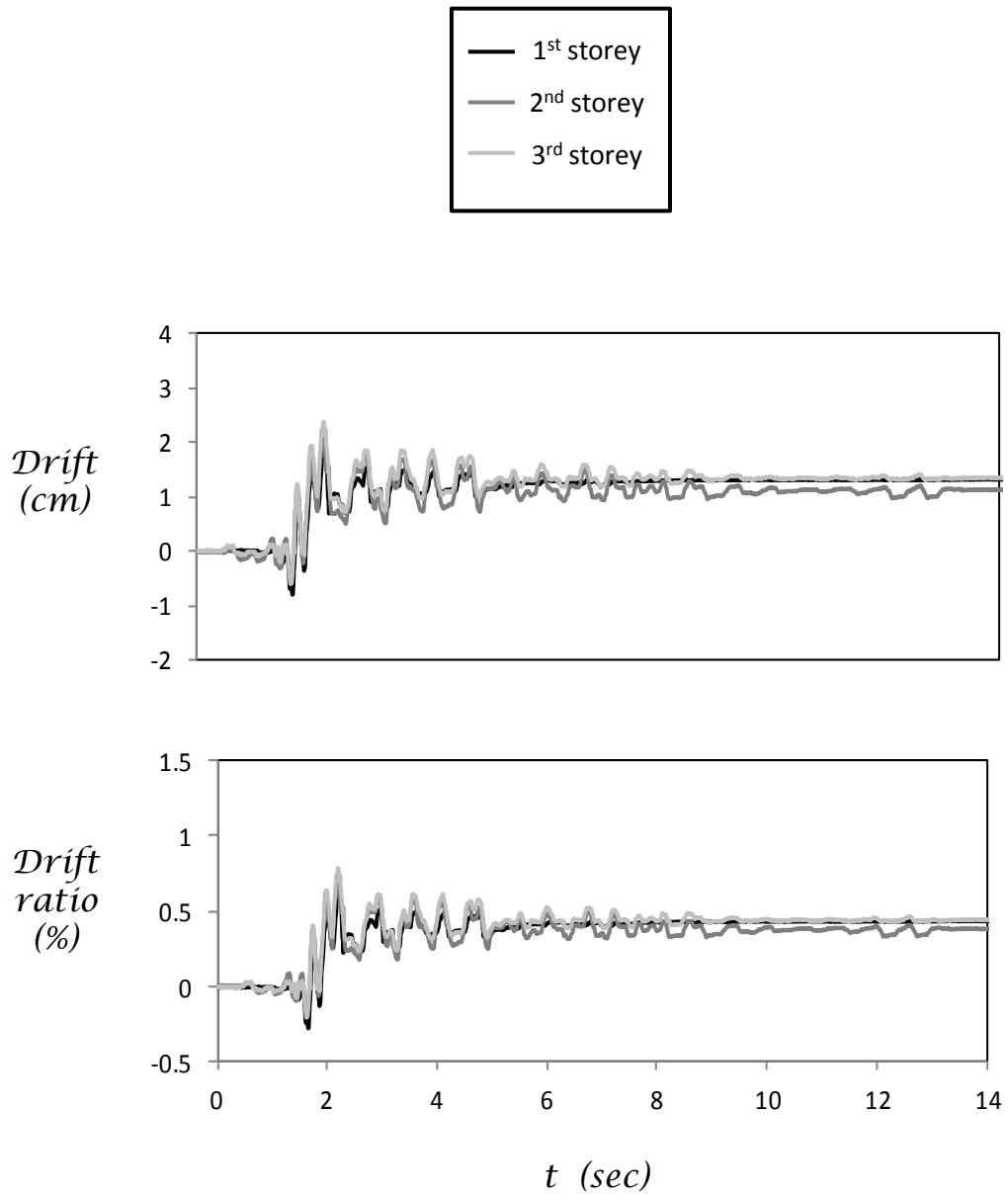

Figure B90. Time histories of storey drift and drift ratio of retrofitted building with rocking isolation ($b = 2.5\text{m}$, $t = 0.10\text{m}$) while submitted to the record of MNSA.

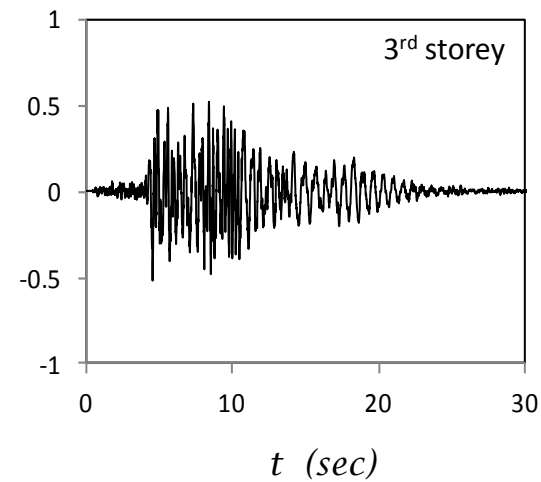
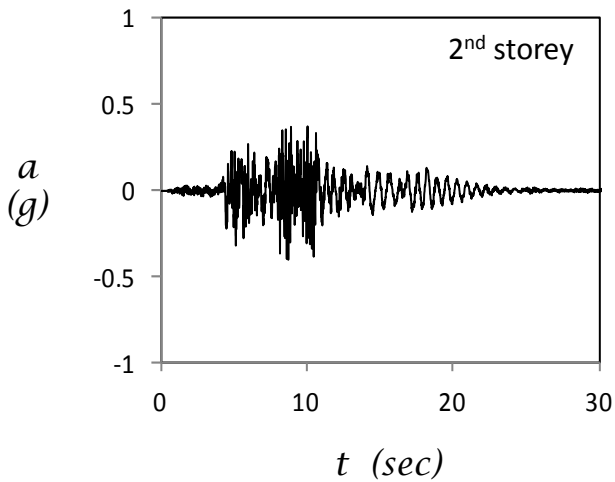
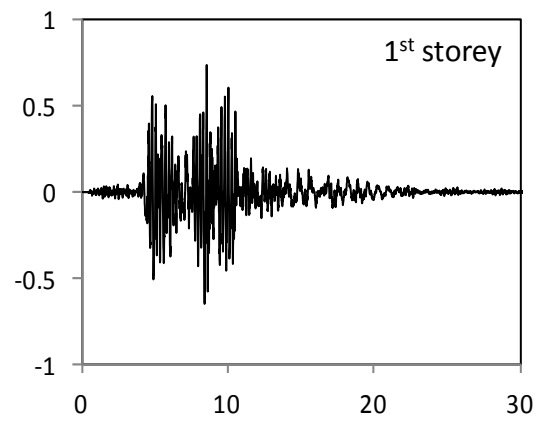
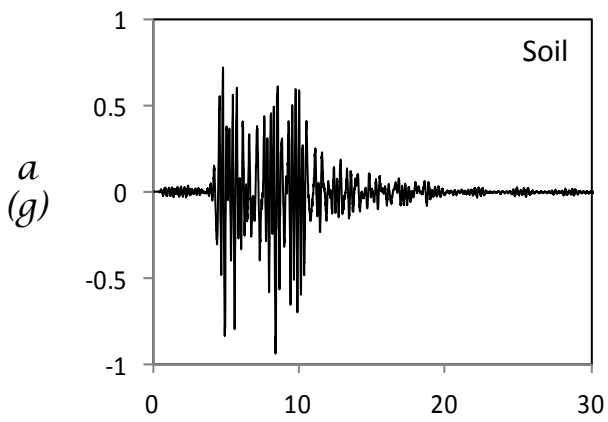
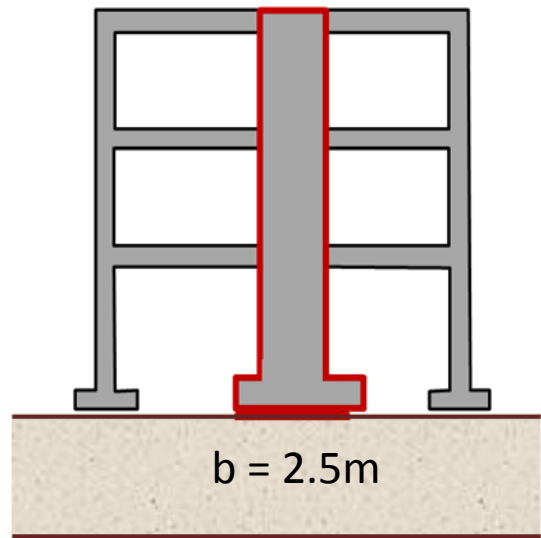
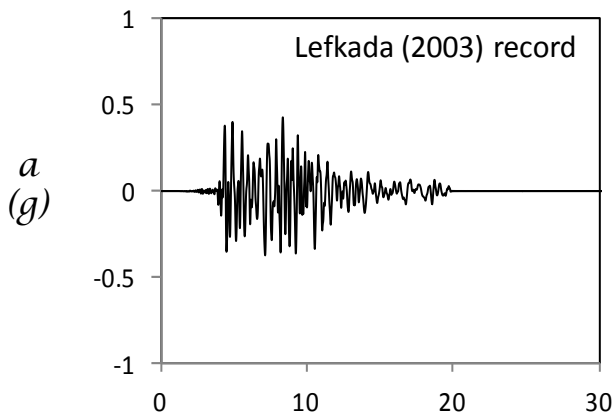

Figure B91. Acceleration time histories measured on the retrofitted building with rocking isolation ($b = 2.5\text{m}$, $t = 0.10\text{m}$) while submitted to the record of Lefkada (2003).

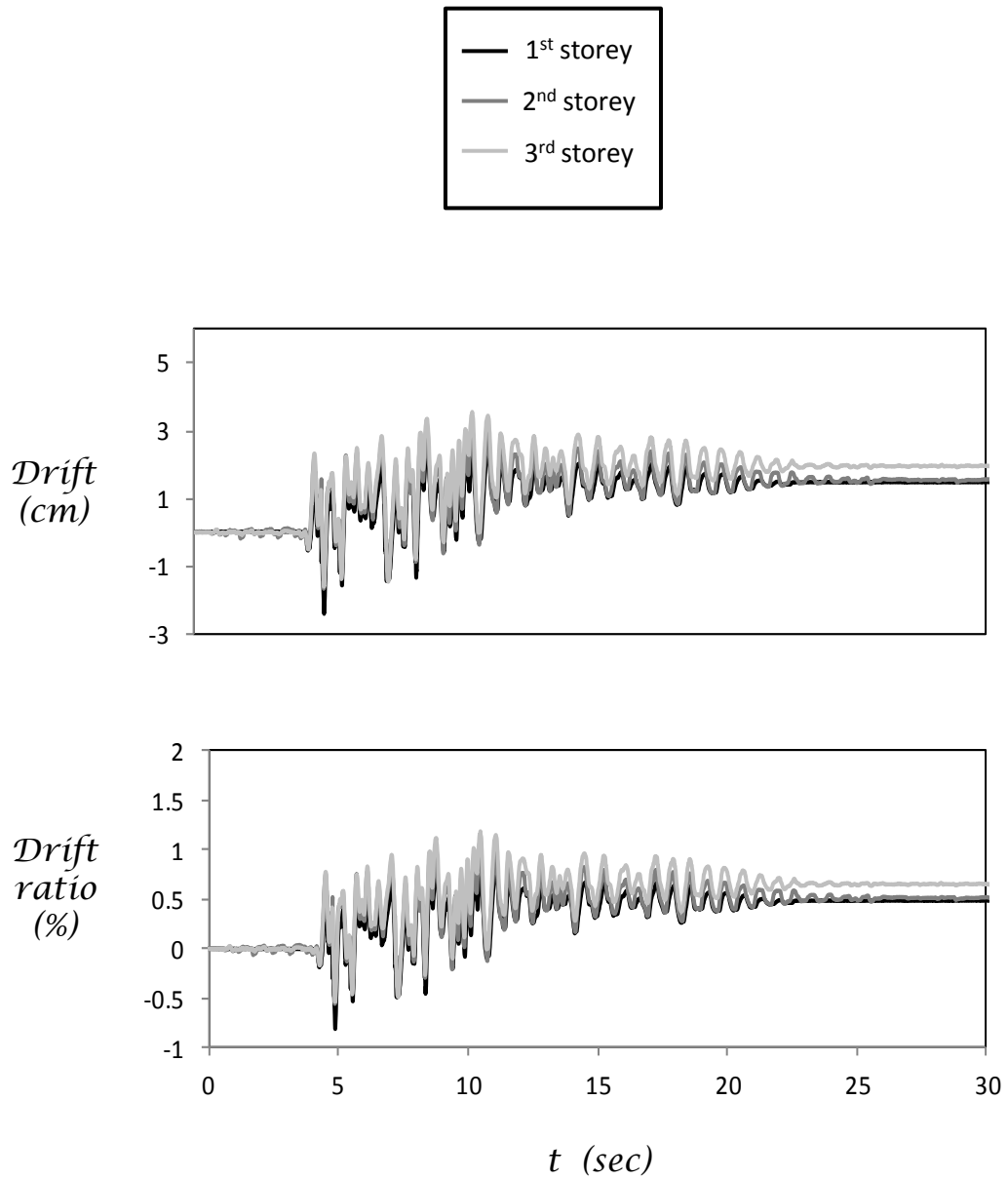

Figure B92. Time histories of storey drift and drift ratio of retrofitted building with rocking isolation ($b = 2.5\text{m}$, $t = 0.10\text{m}$) while submitted to the record of Lefkada (2003).

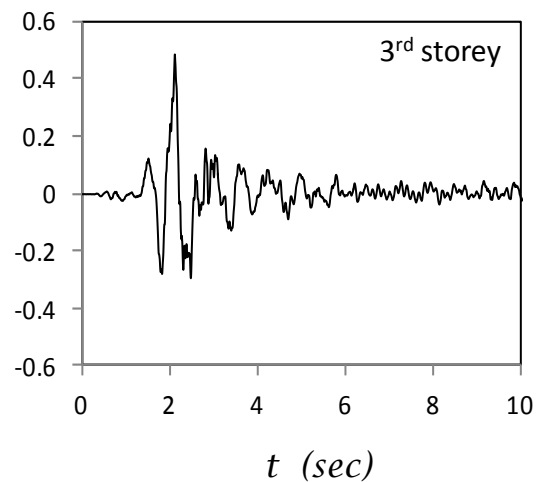
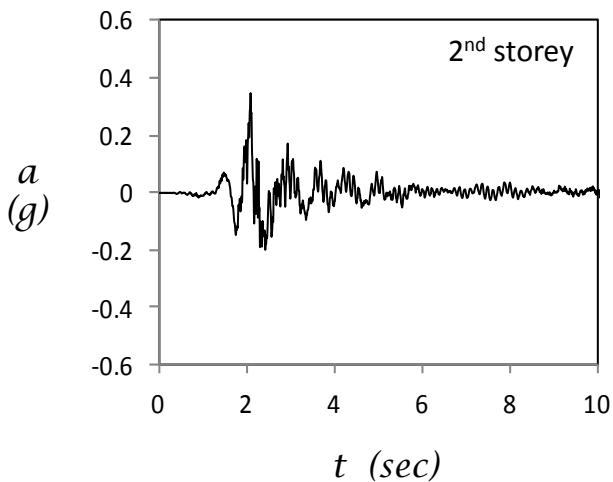
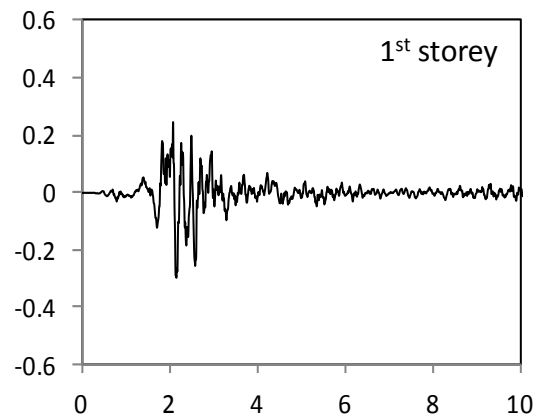
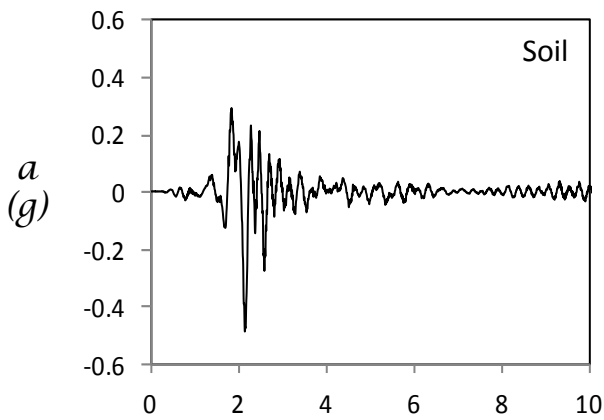
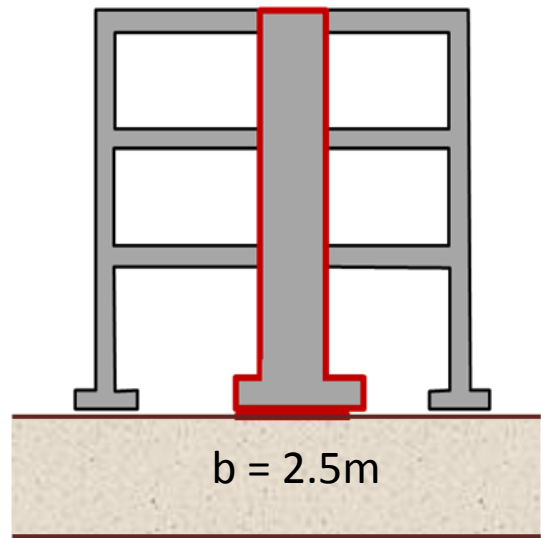
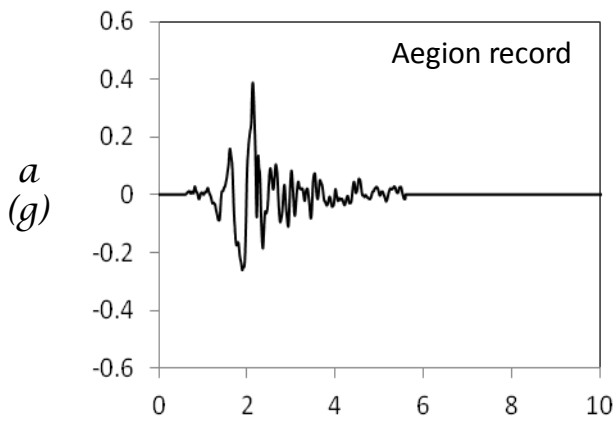

Figure B93. Acceleration time histories measured on the retrofitted building with rocking isolation ($b = 2.5\text{m}$, $t = 0.10\text{m}$) while submitted to the record of Aegion.

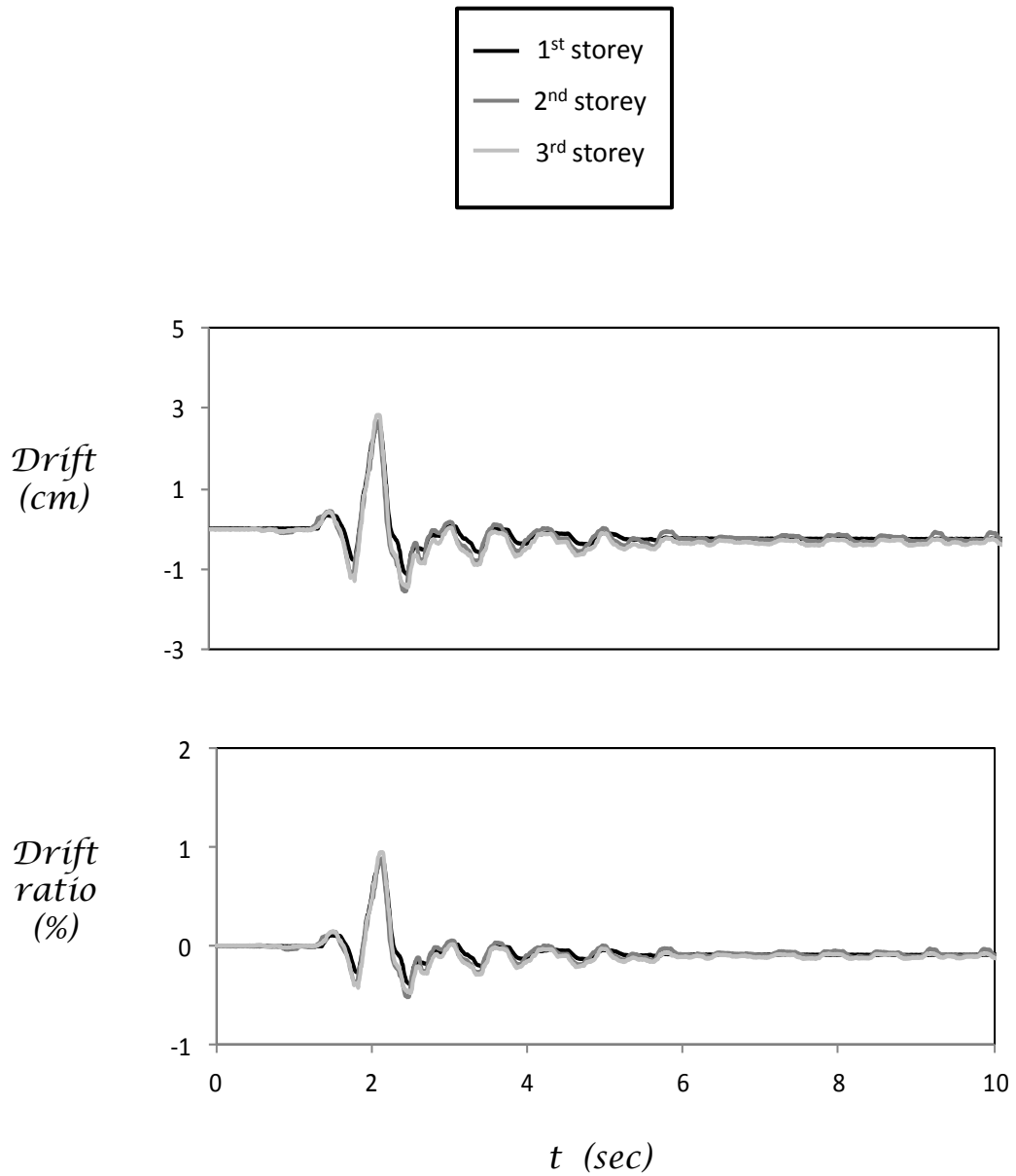

Figure B94. Time histories of storey drift and drift ratio of retrofitted building with rocking isolation ($b = 2.5\text{m}$, $t = 0.10\text{m}$) while submitted to the record of Aegion.

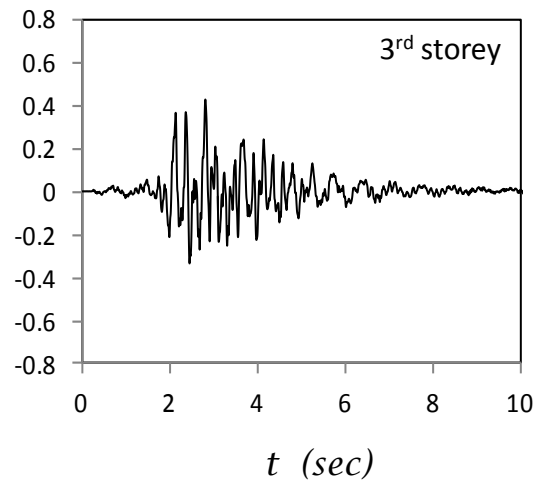
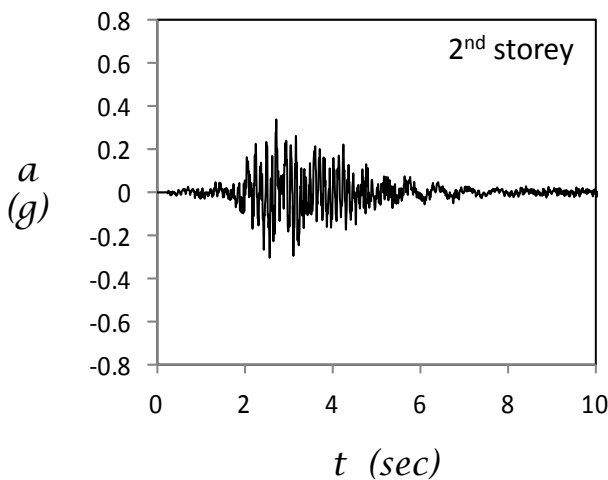
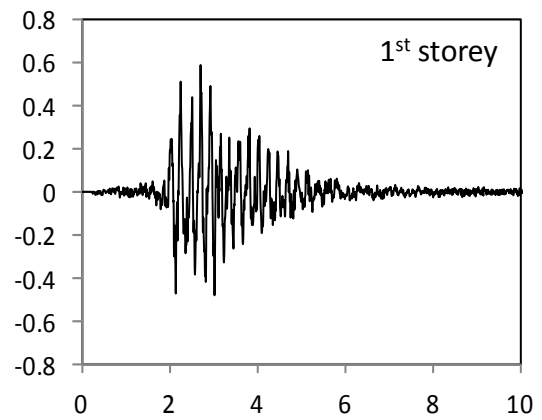
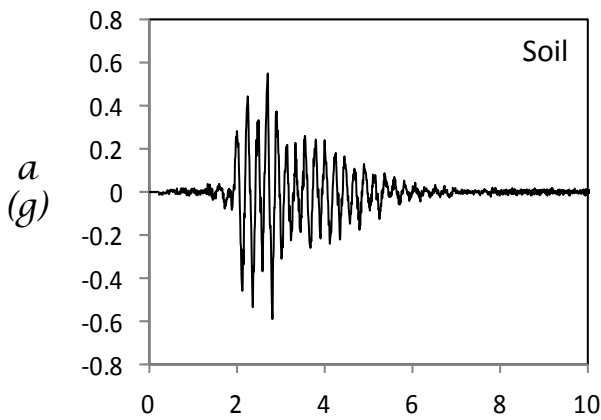
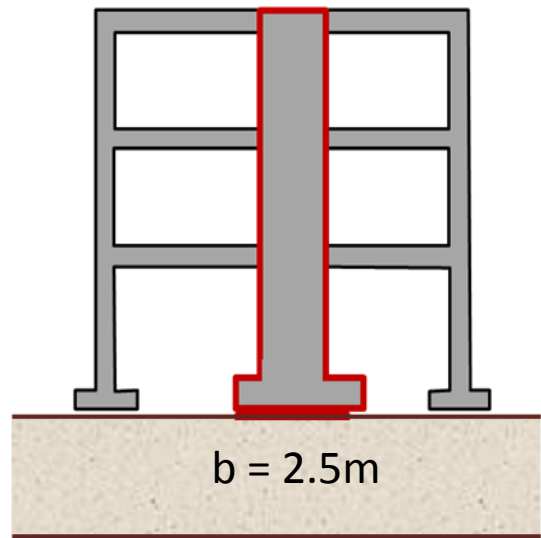
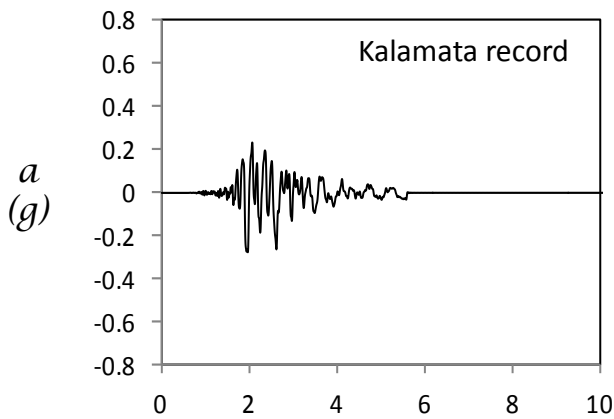

Figure B95. Acceleration time histories measured on the retrofitted building with rocking isolation ($b = 2.5\text{m}$, $t = 0.10\text{m}$) while submitted to the record of Kalamata.

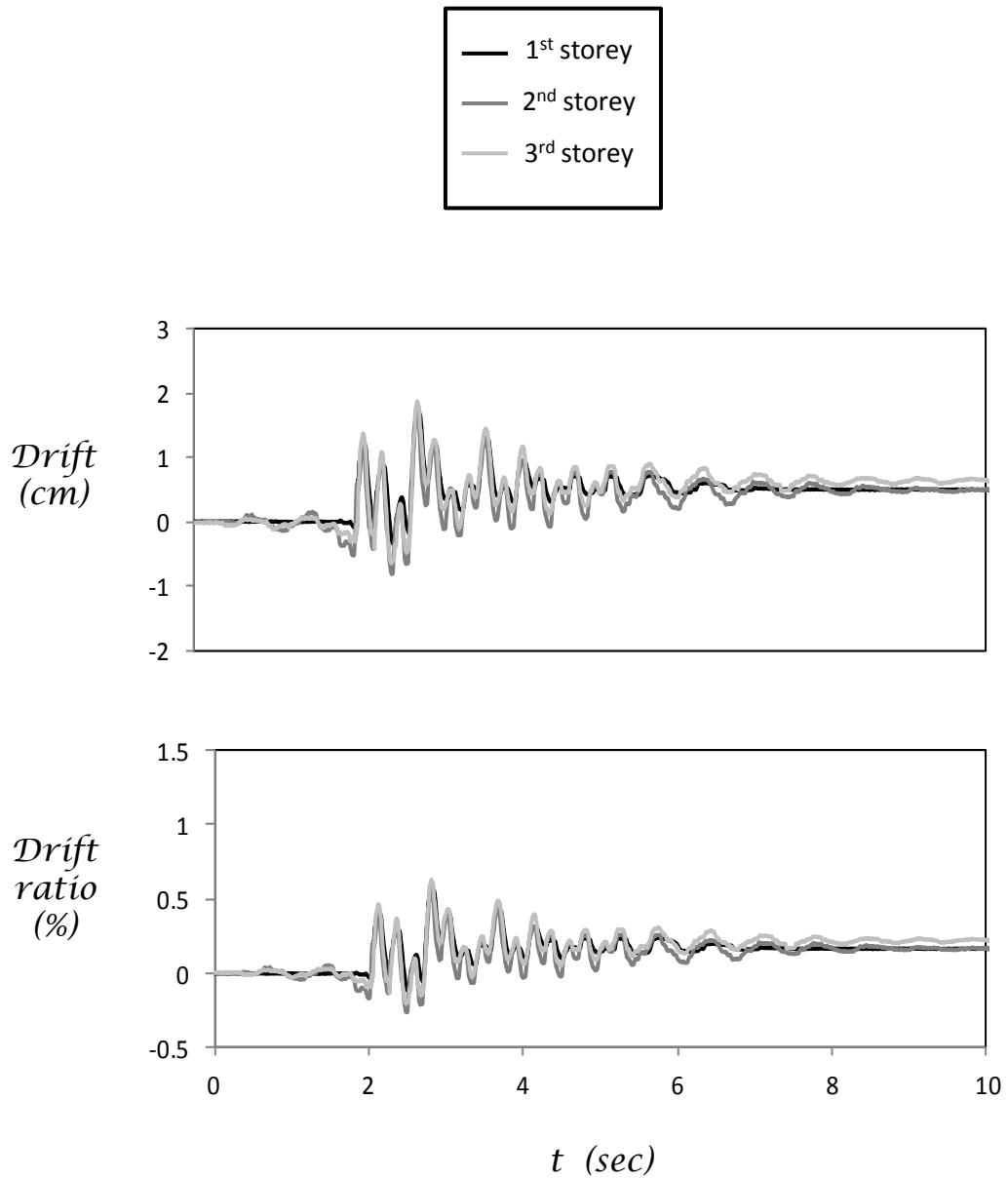

Figure B96. Time histories of storey drift and drift ratio of retrofitted building with rocking isolation ($b = 2.5\text{m}$, $t = 0.10\text{m}$) while submitted to the record of Kalamata.

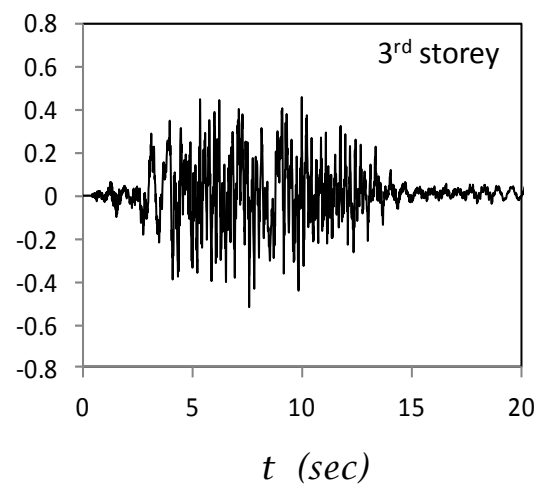
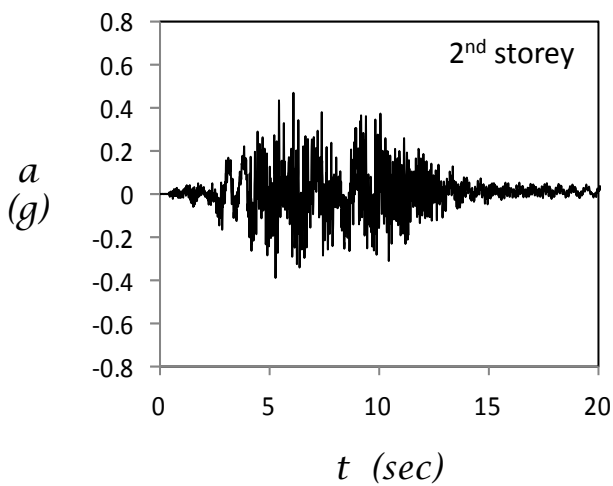
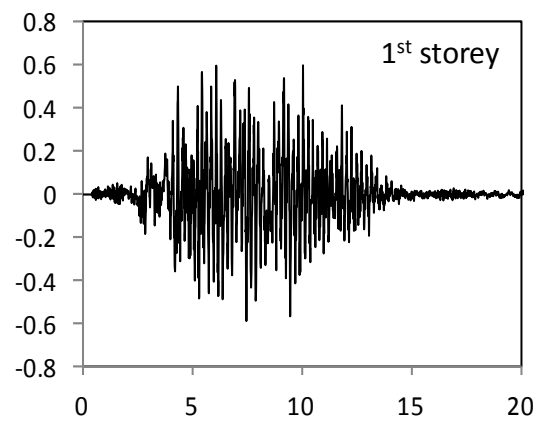
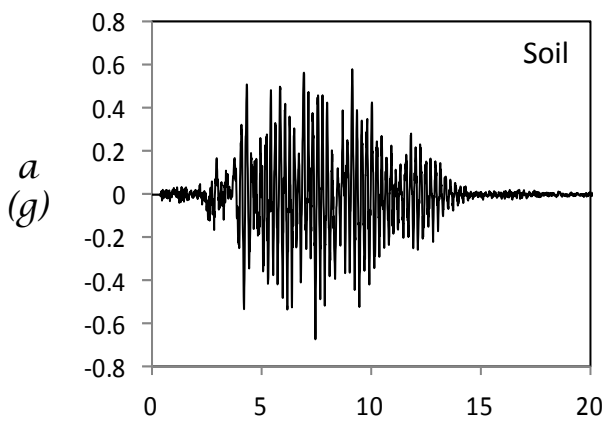
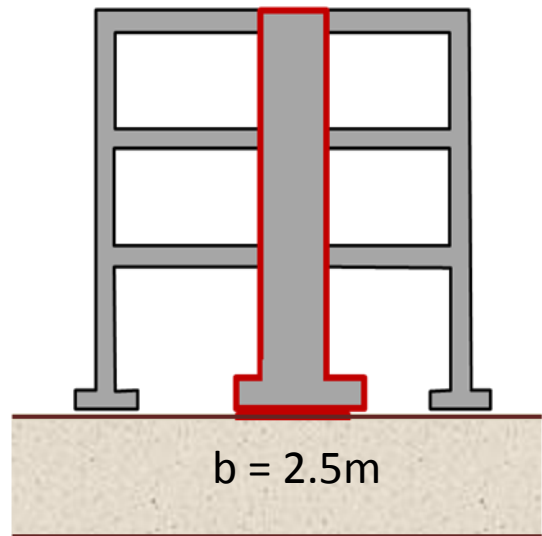
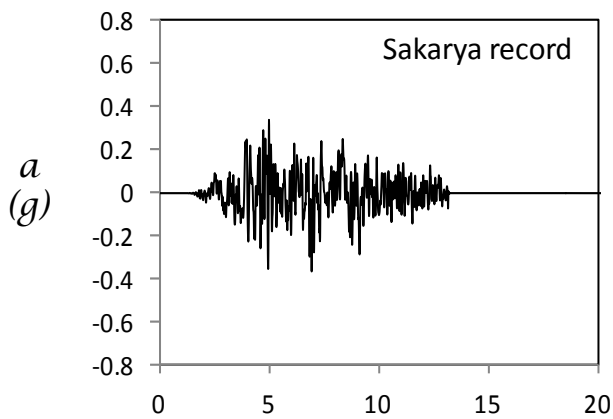

Figure B97. Acceleration time histories measured on the retrofitted building with rocking isolation ($b = 2.5\text{m}$, $t = 0.10\text{m}$) while submitted to the record of Sakarya.

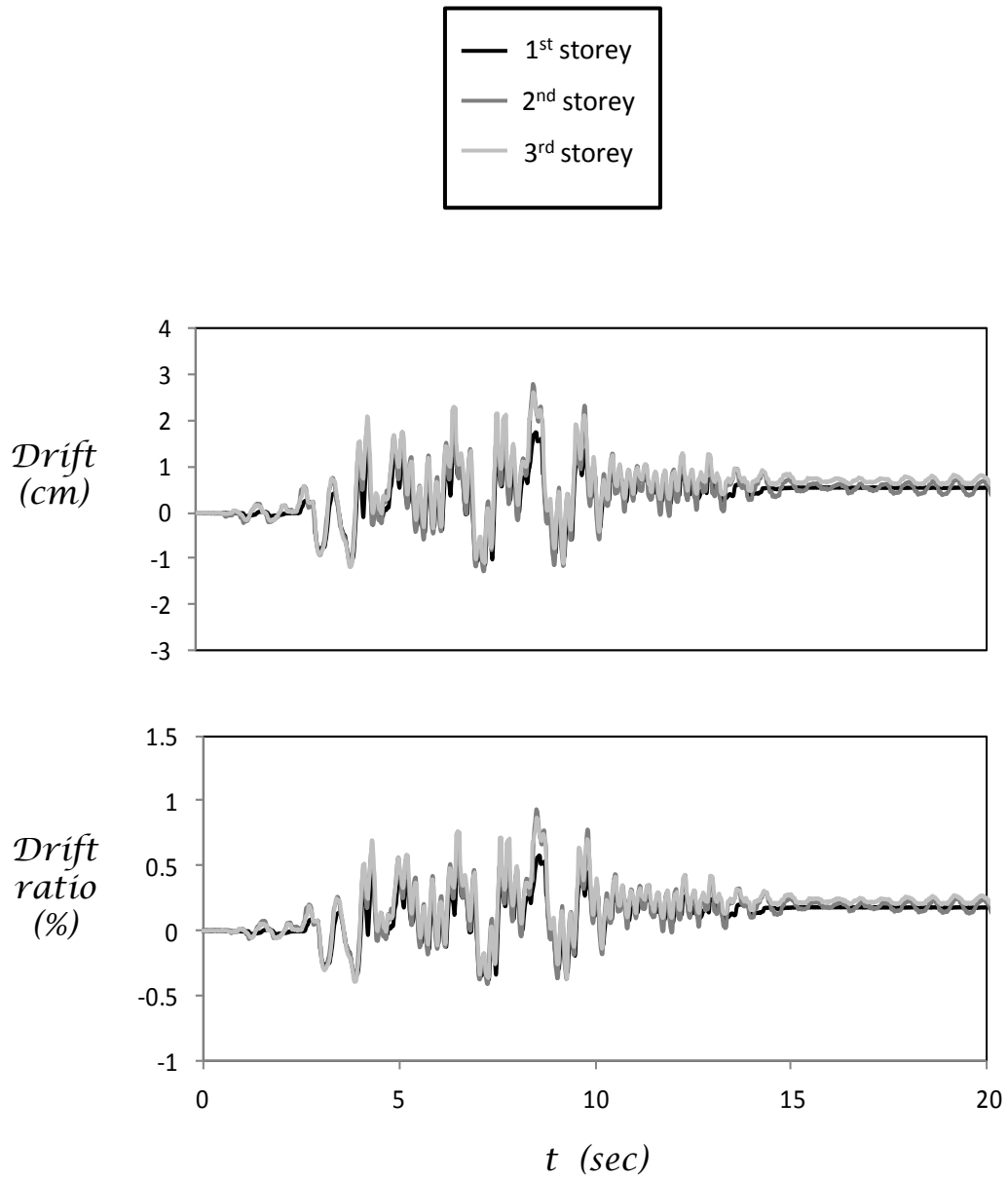

Figure B98. Time histories of storey drift and drift ratio of retrofitted building with rocking isolation ($b = 2.5\text{m}$, $t = 0.10\text{m}$) while submitted to the record of Sakarya.

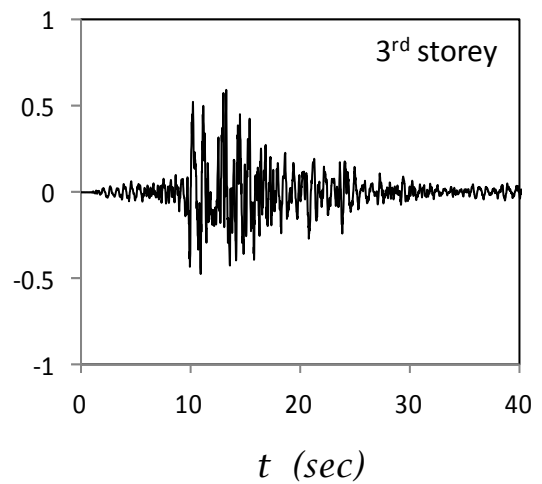
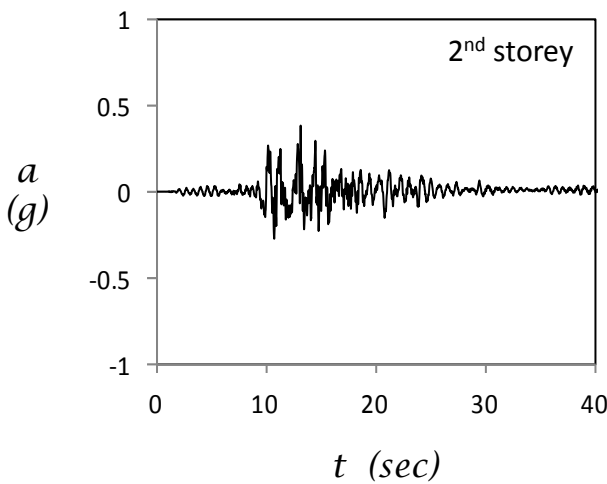
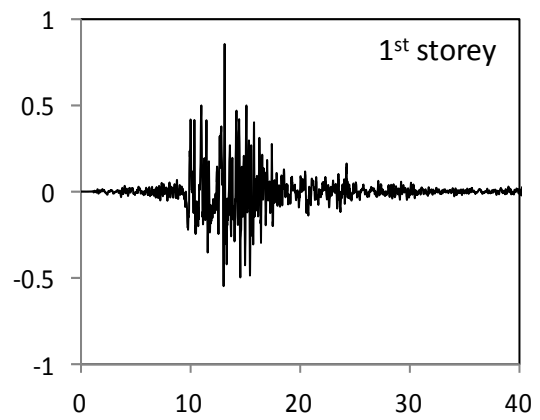
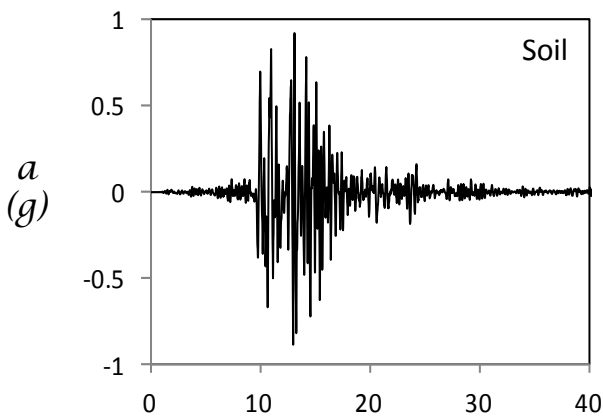
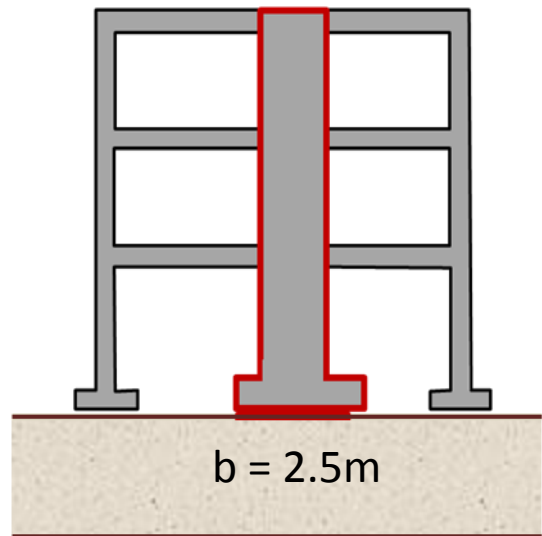
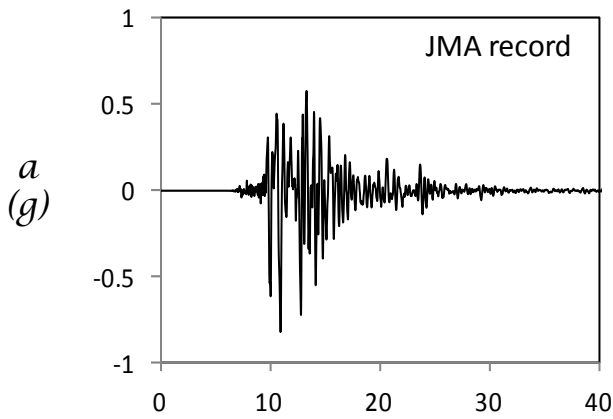

Figure B99. Acceleration time histories measured on the retrofitted building with rocking isolation ($b = 2.5\text{m}$, $t = 0.10\text{m}$) while submitted to the record of JMA.

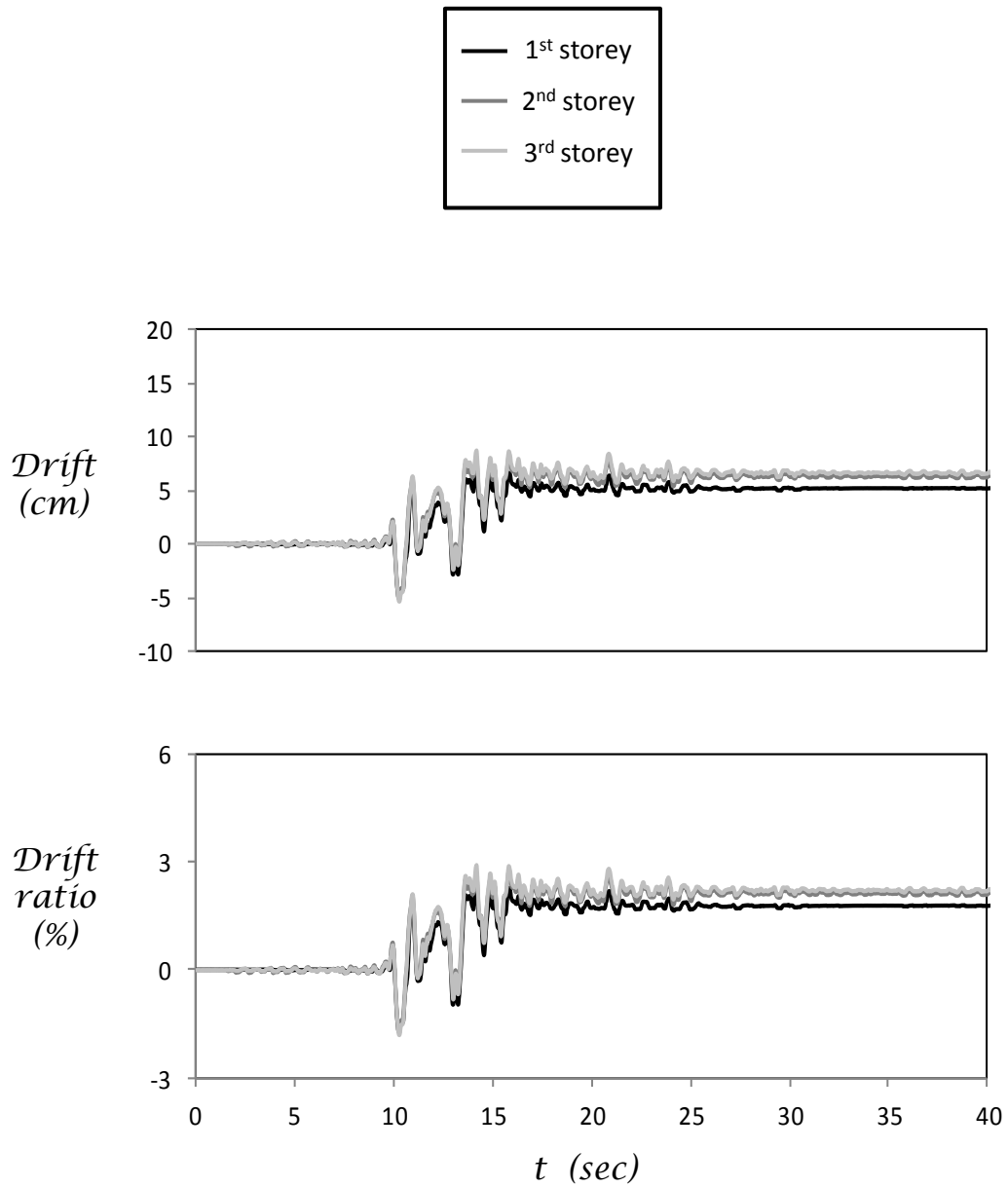

Figure B100. Time histories of storey drift and drift ratio of retrofitted building with rocking isolation ($b = 2.5\text{m}$, $t = 0.10\text{m}$) while submitted to the record of JMA.

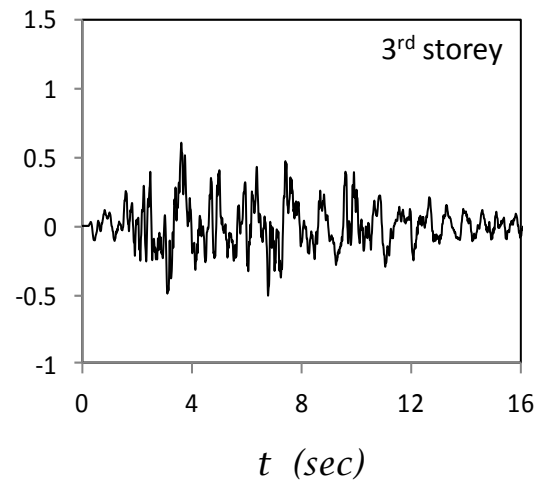
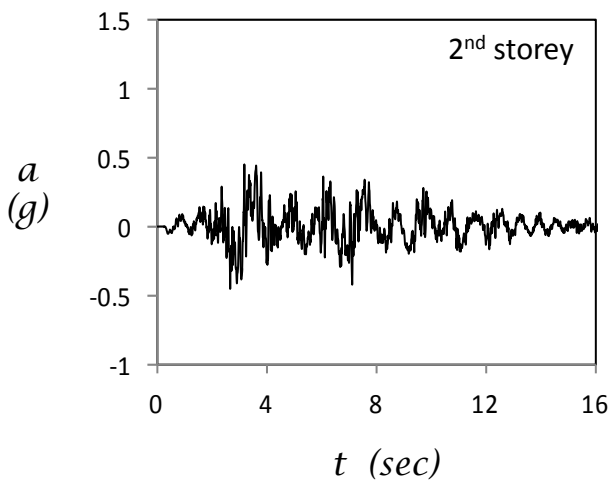
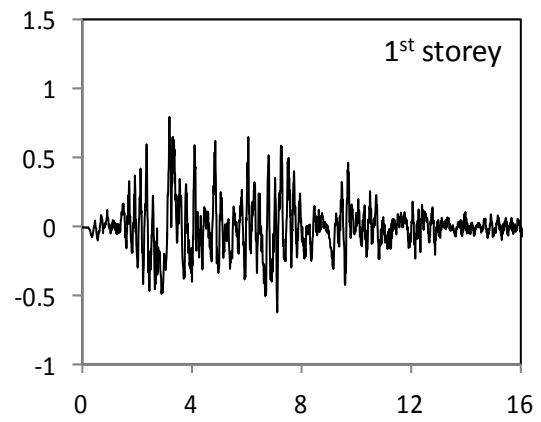
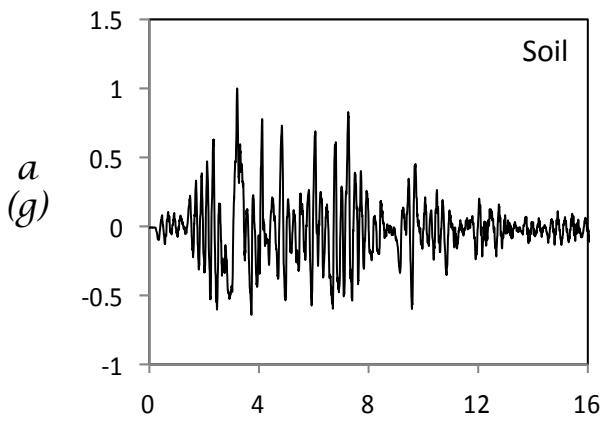
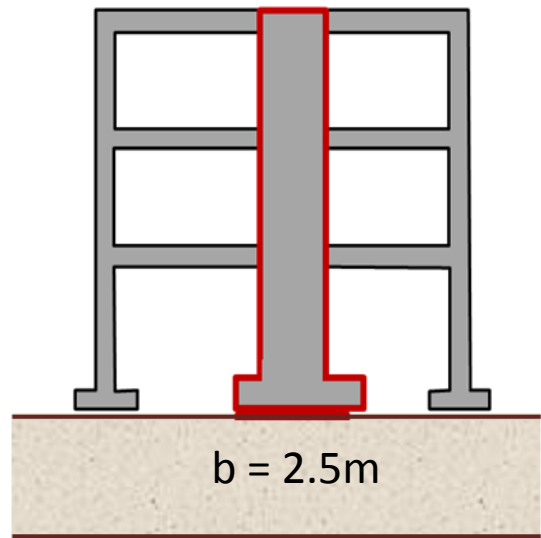
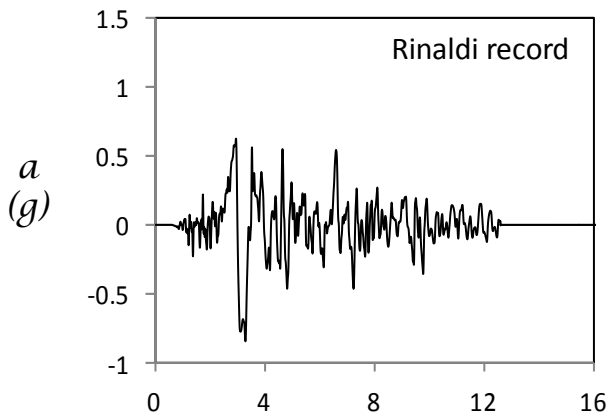

Figure B101. Acceleration time histories measured on the retrofitted building with rocking isolation ($b = 2.5\text{m}$, $t = 0.10\text{m}$) while submitted to the record of Rinaldi.

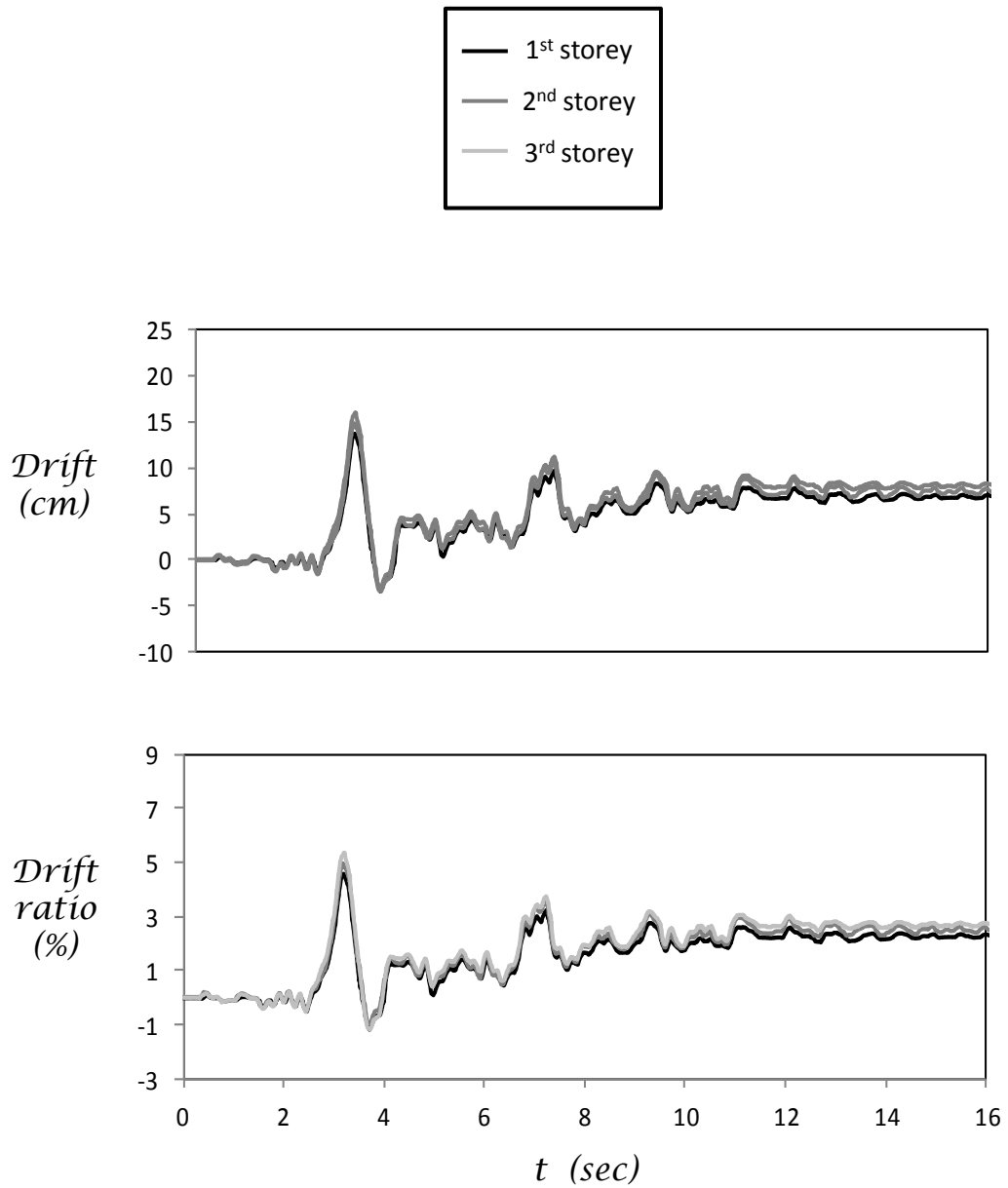
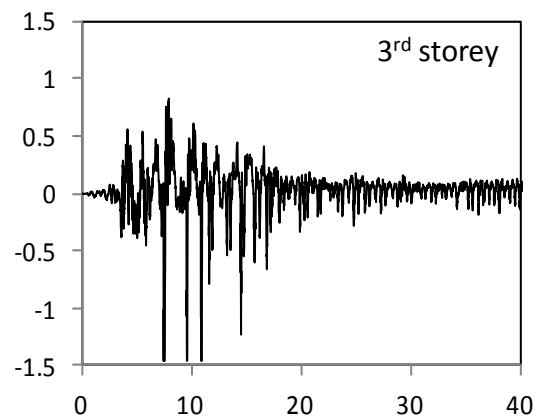
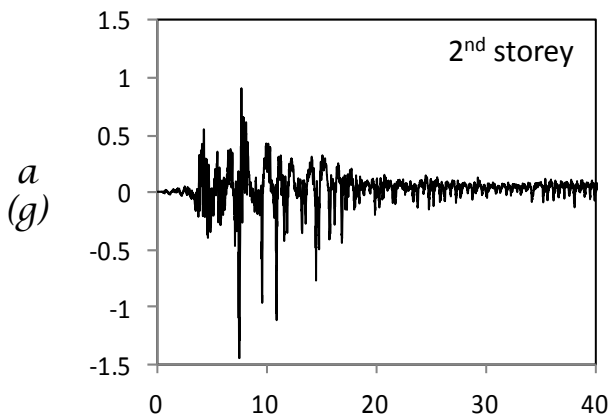
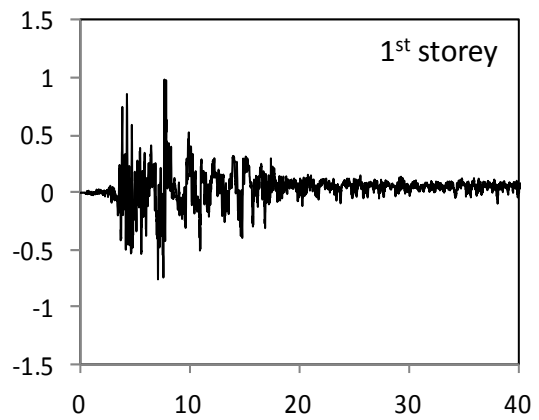
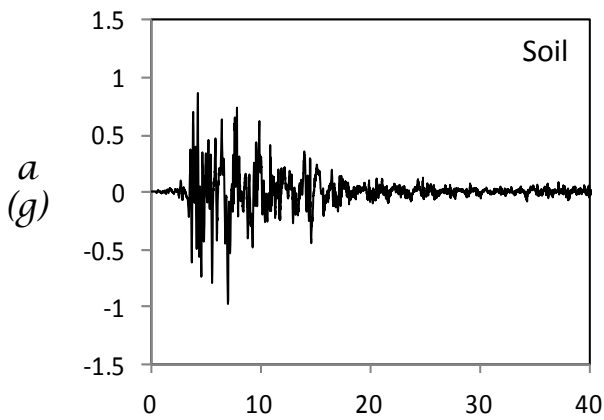
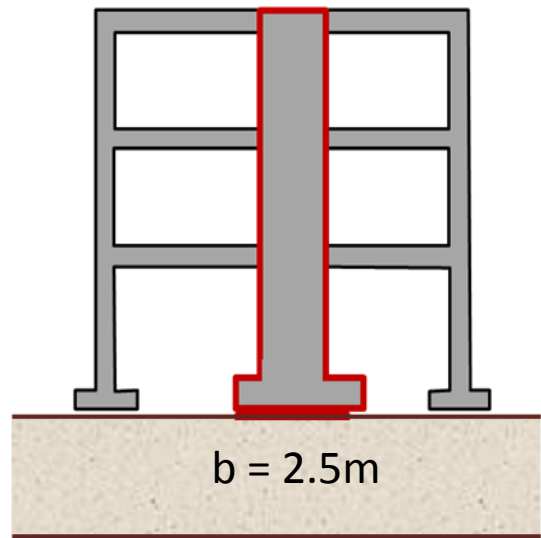
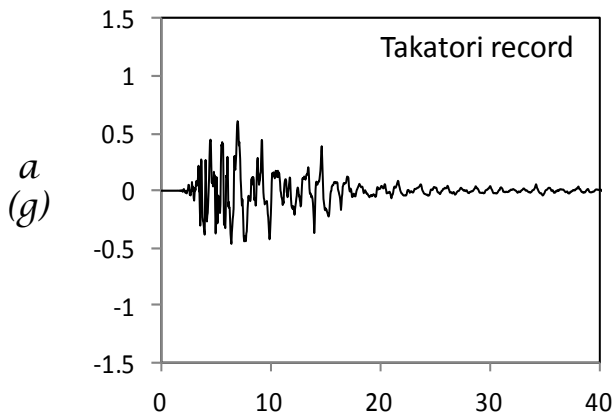

Figure B102. Time histories of storey drift and drift ratio of retrofitted building with rocking isolation ($b = 2.5\text{m}$, $t = 0.10\text{m}$) while submitted to the record of Rinaldi.



t (sec)

t (sec)

Figure B103. Acceleration time histories measured on the retrofitted building with rocking isolation ($b = 2.5\text{m}$, $t = 0.10\text{m}$) while submitted to the record of Takatori.

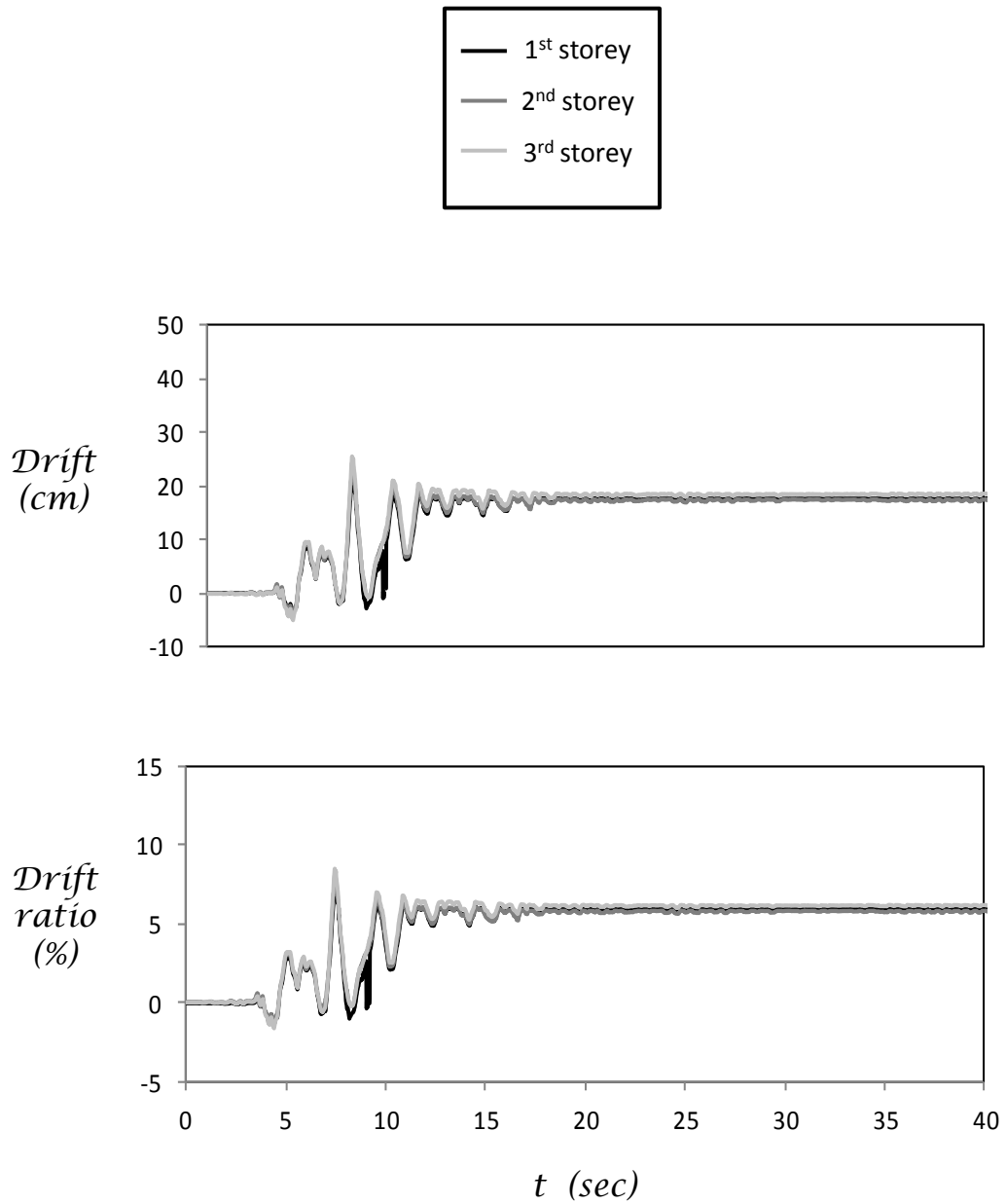

Figure B104. Time histories of storey drift and drift ratio of retrofitted building with rocking isolation ($b = 2.5\text{m}$, $t = 0.10\text{m}$) while submitted to the record of Takatori.

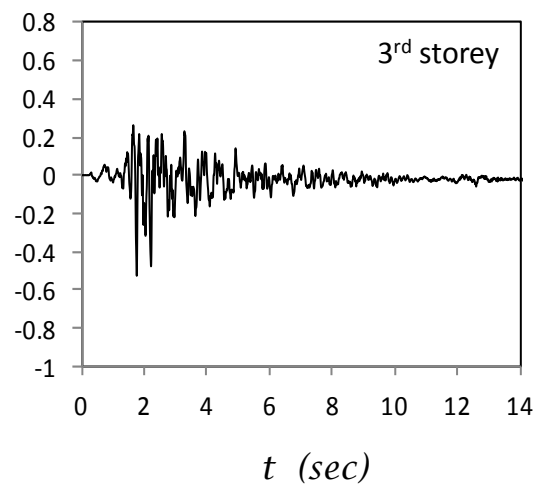
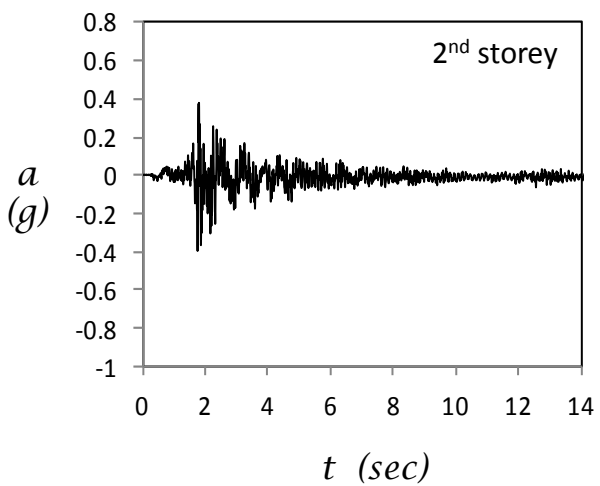
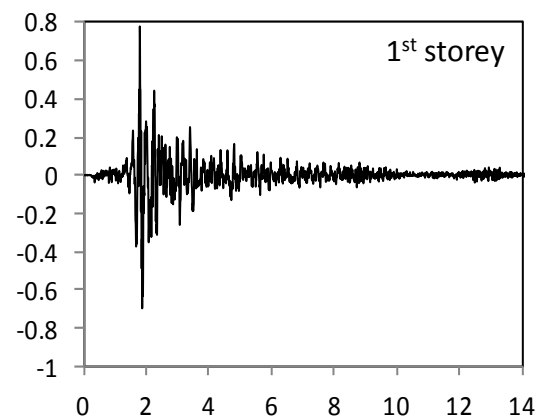
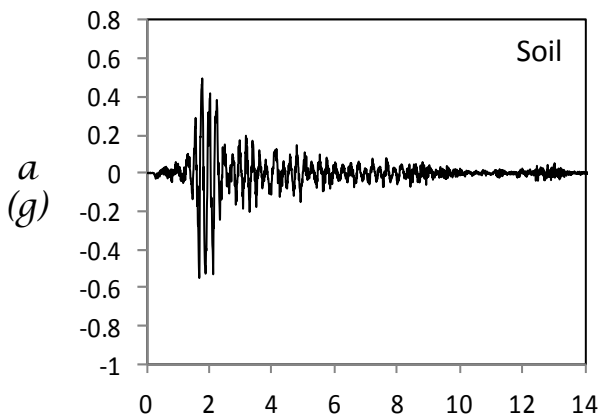
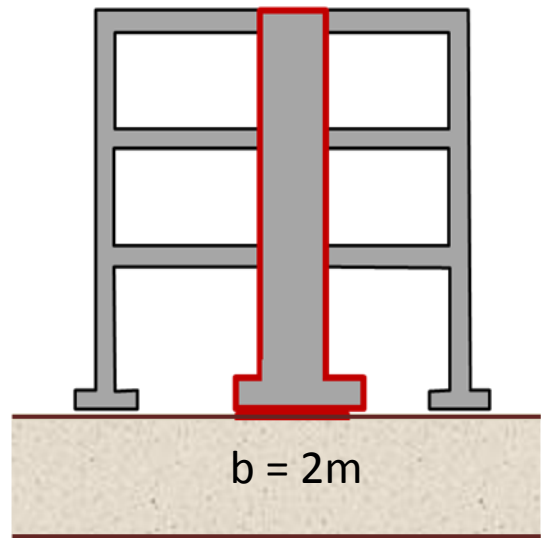
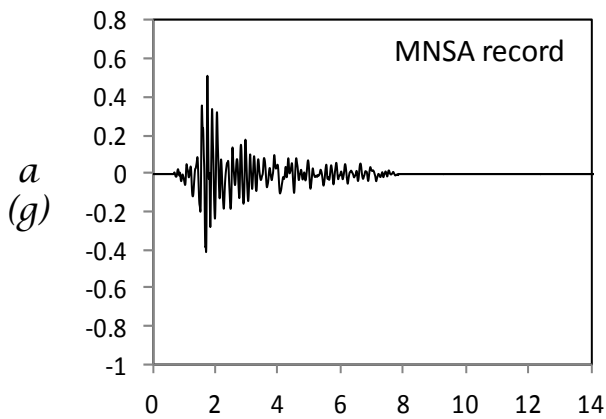

Figure B105. Acceleration time histories measured on the retrofitted building with rocking isolation ($b = 2\text{m}$, $t = 0.10\text{m}$) while submitted to the record of MNSA.

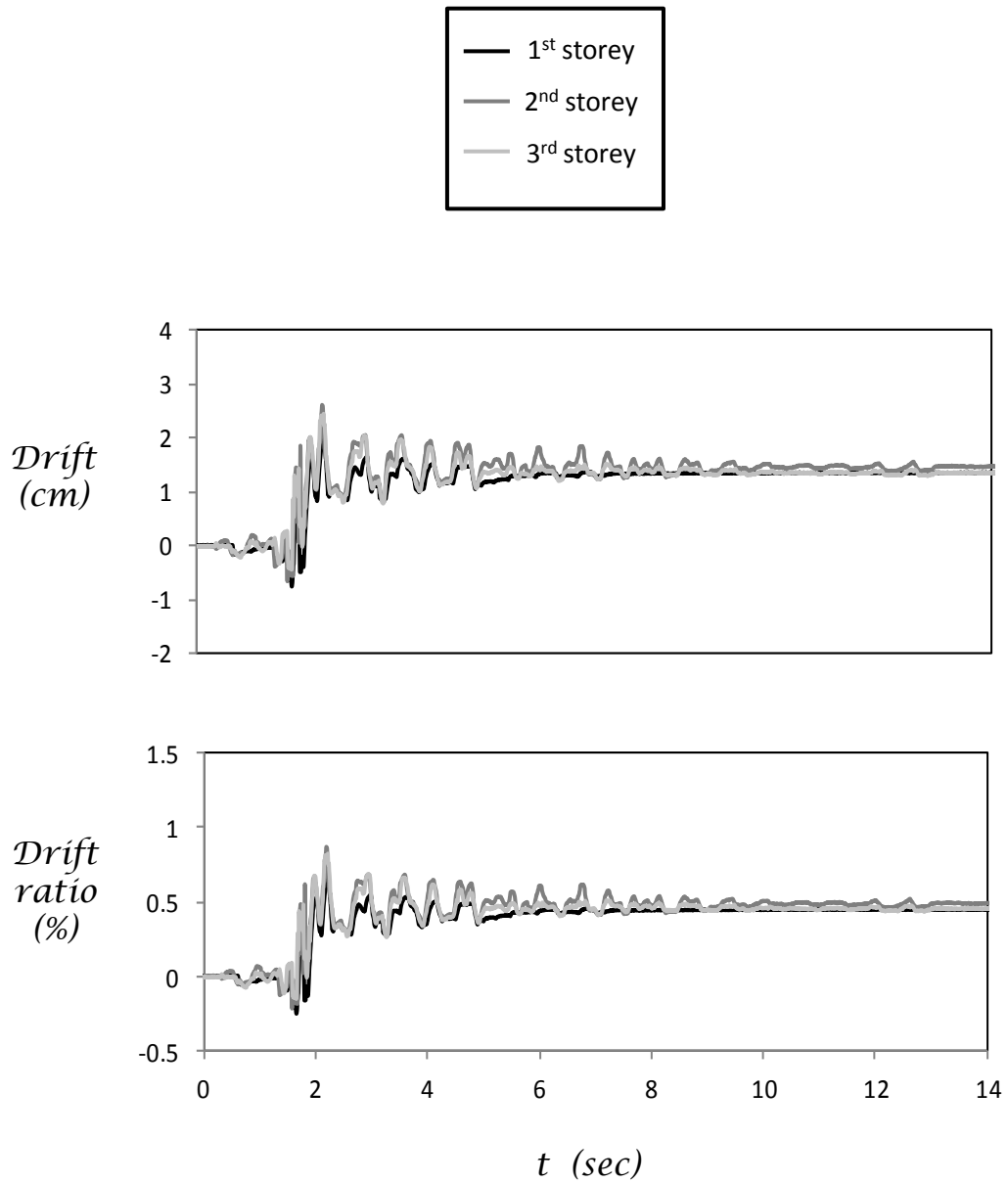

Figure B106. Time histories of storey drift and drift ratio of retrofitted building with rocking isolation ($b = 2\text{m}$, $t = 0.10\text{m}$) while submitted to the record of MNSA.

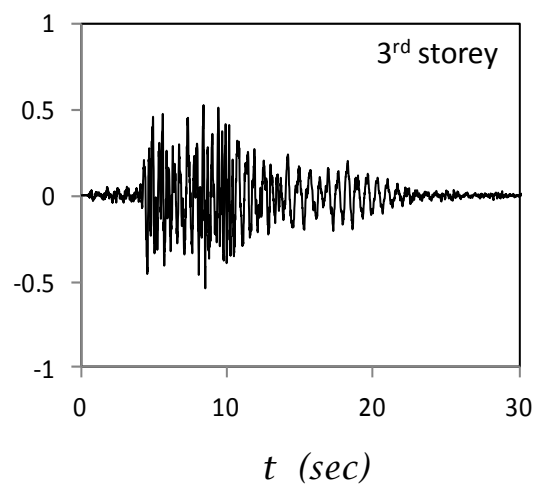
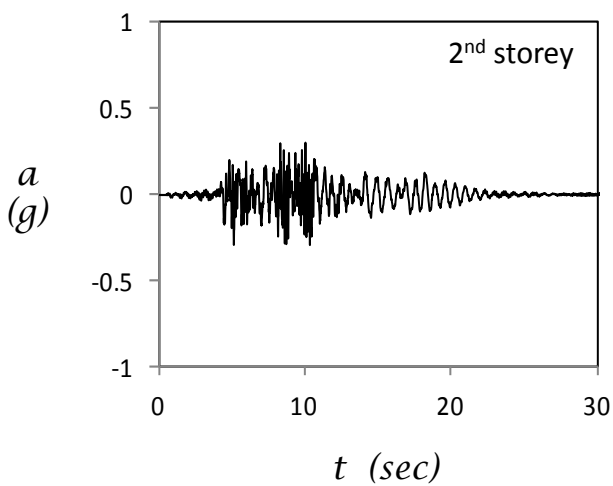
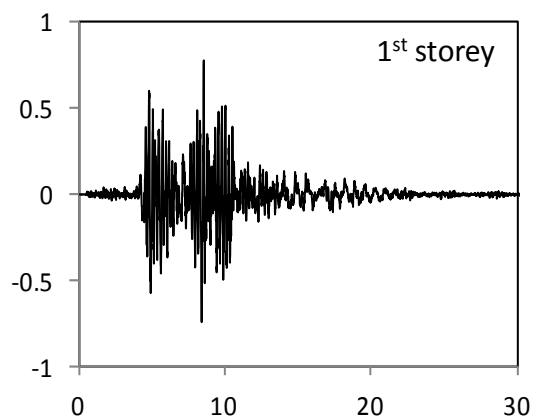
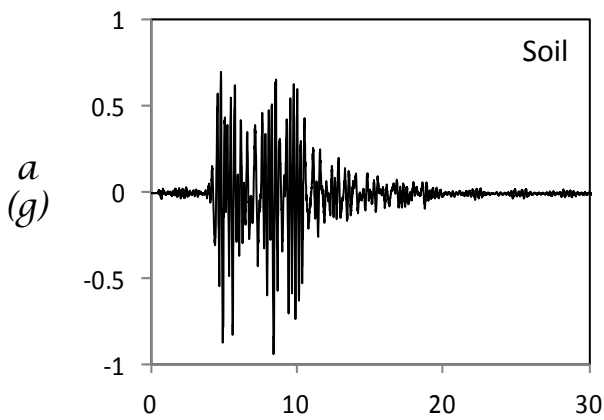
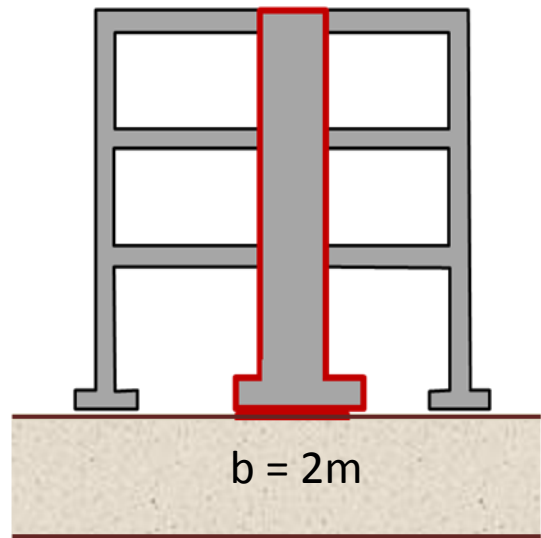
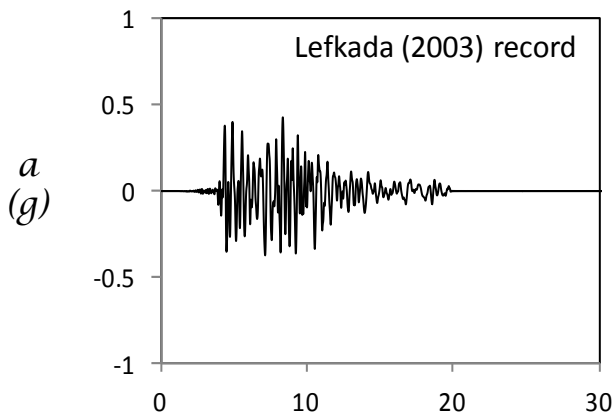

Figure B107. Acceleration time histories measured on the retrofitted building with rocking isolation ($b = 2\text{m}$, $t = 0.10\text{m}$) while submitted to the record of Lefkada (2003).

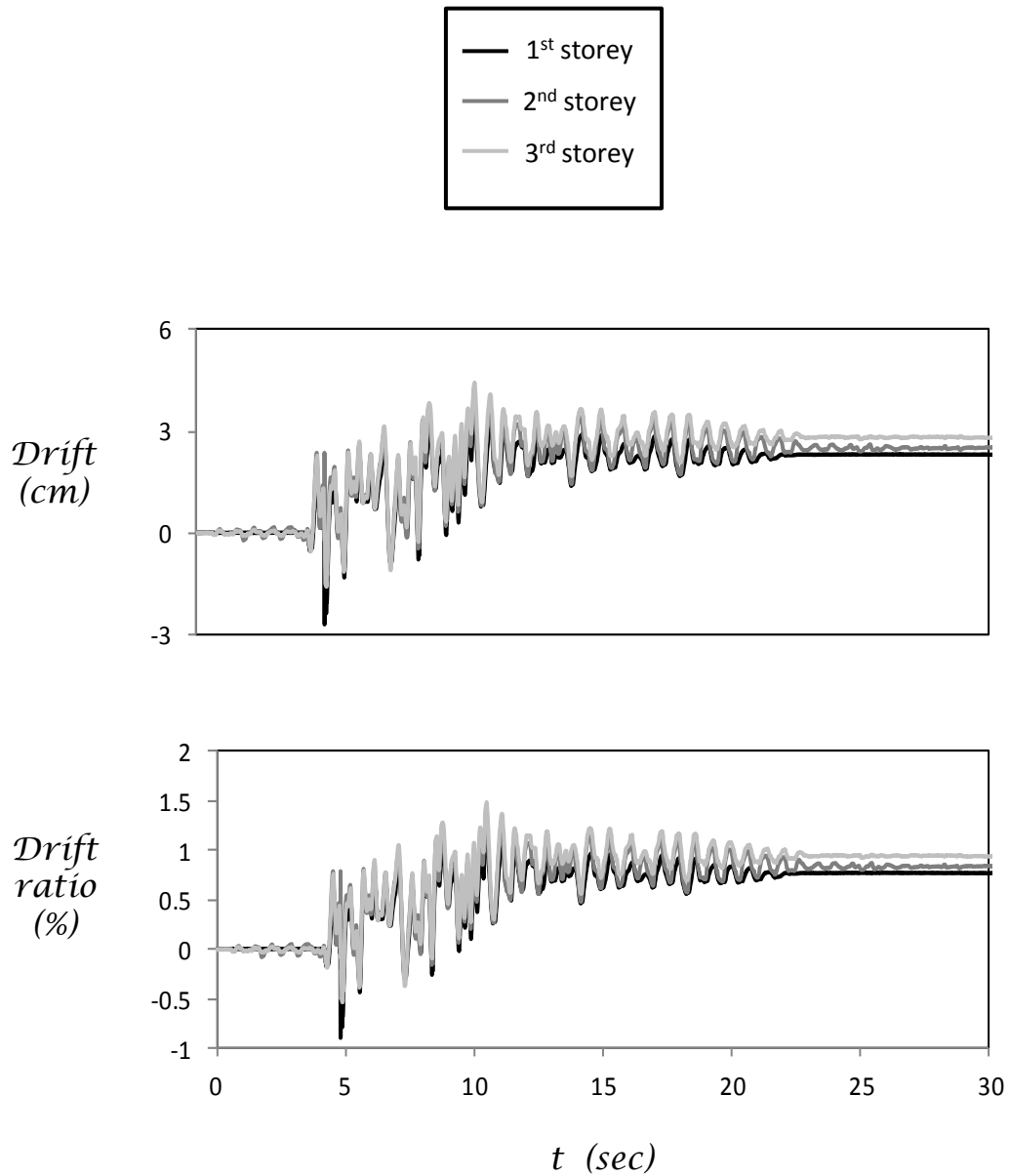

Figure B108. Time histories of storey drift and drift ratio of retrofitted building with rocking isolation ($b = 2\text{m}$, $t = 0.10\text{m}$) while submitted to the record of Lefkada (2003).

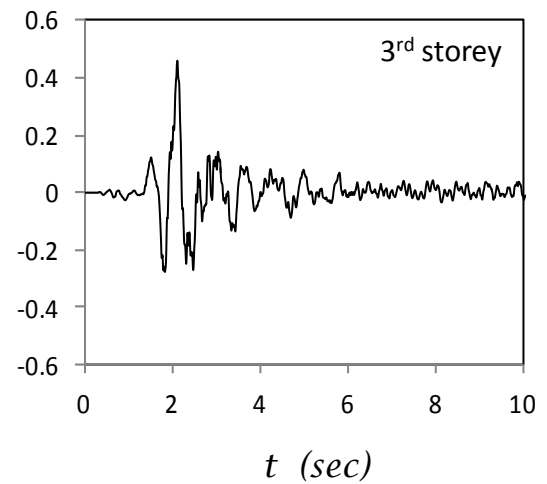
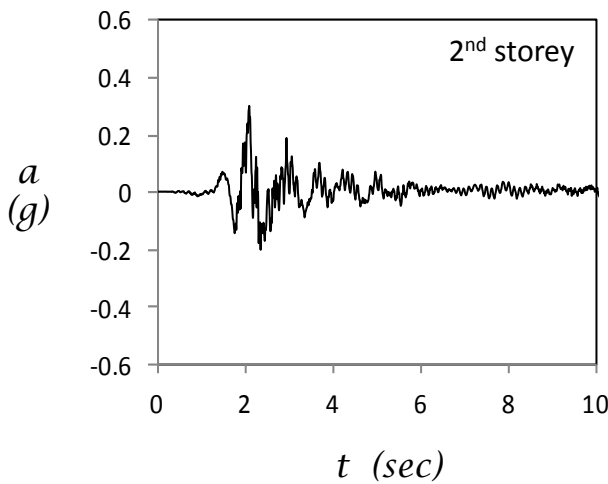
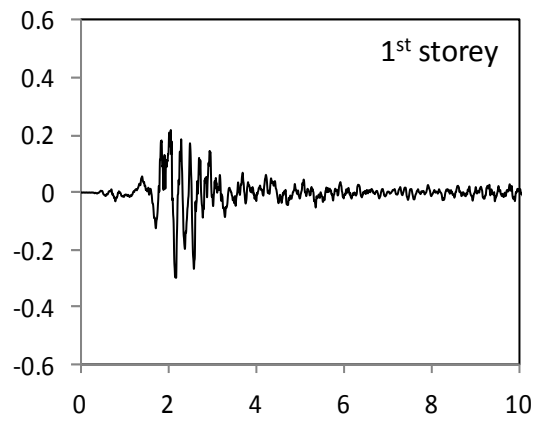
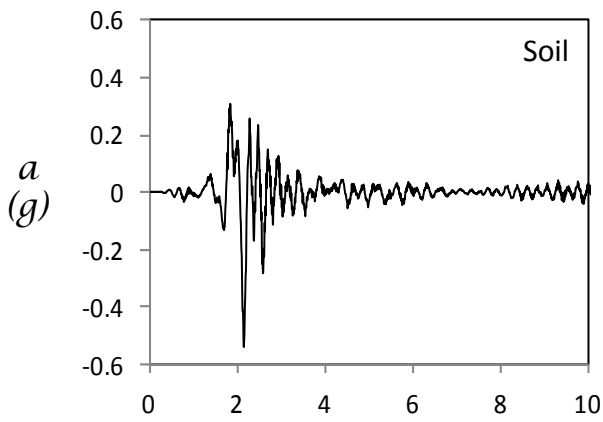
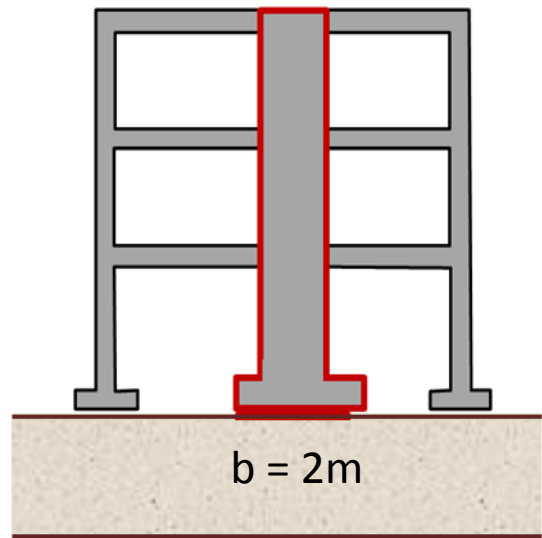
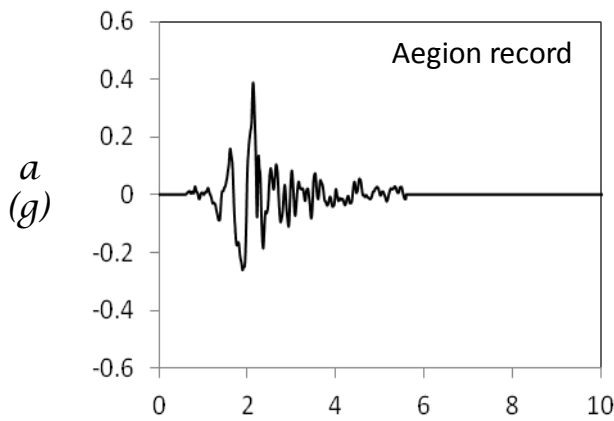

Figure B109. Acceleration time histories measured on the retrofitted building with rocking isolation ($b = 2\text{m}$, $t = 0.10\text{m}$) while submitted to the record of Aegion.

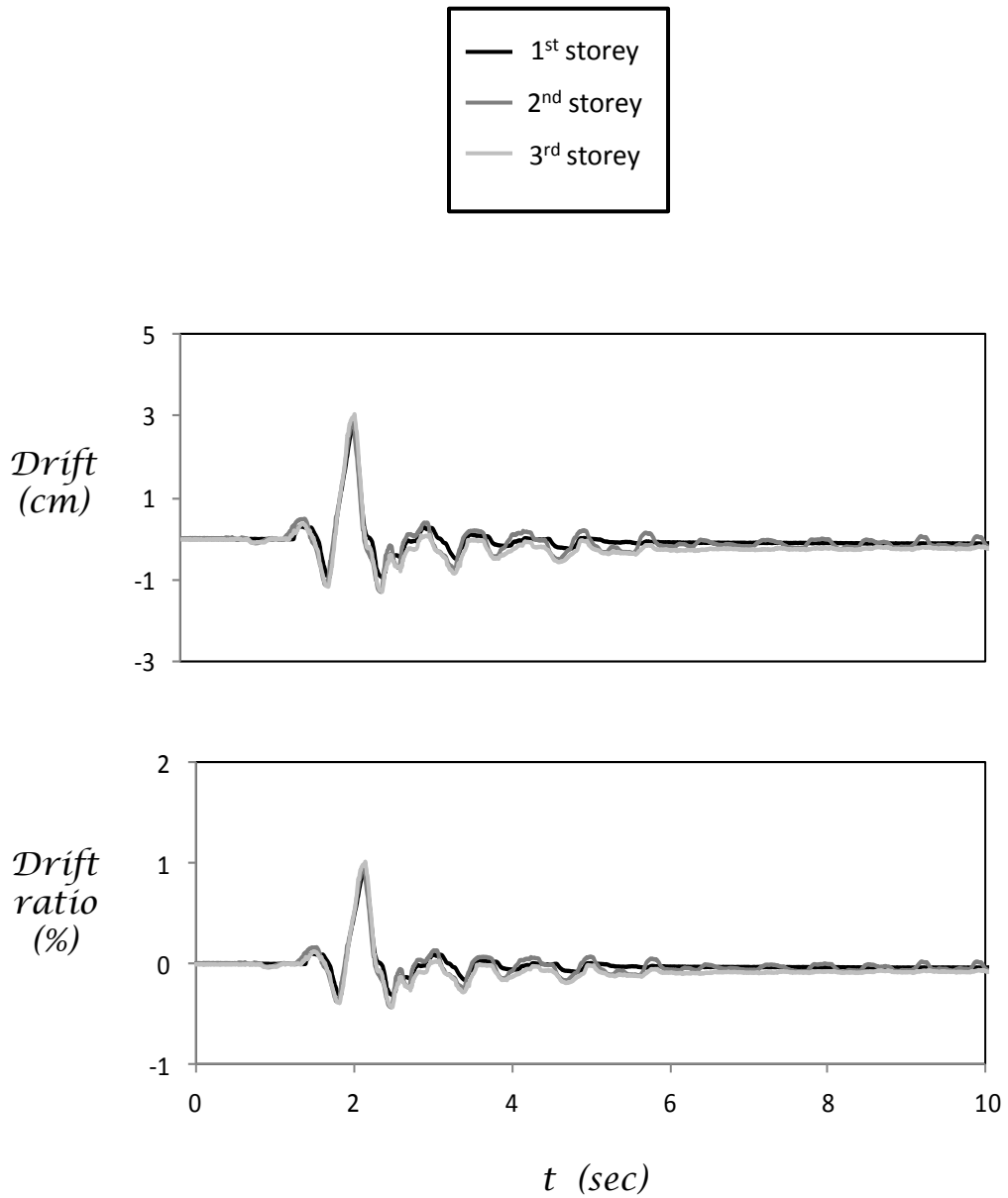

Figure B110. Time histories of storey drift and drift ratio of retrofitted building with rocking isolation ($b = 2\text{m}$, $t = 0.10\text{m}$) while submitted to the record of Aegion.

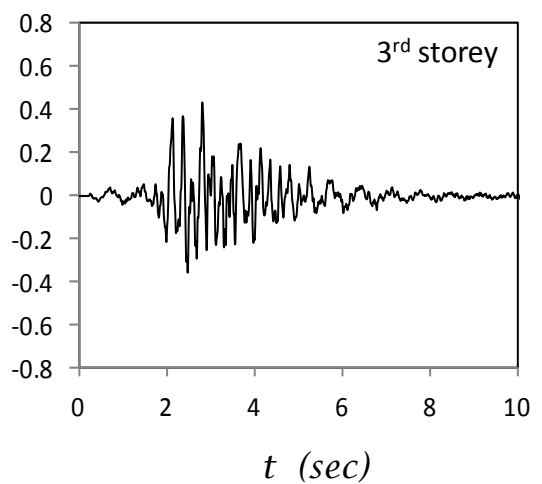
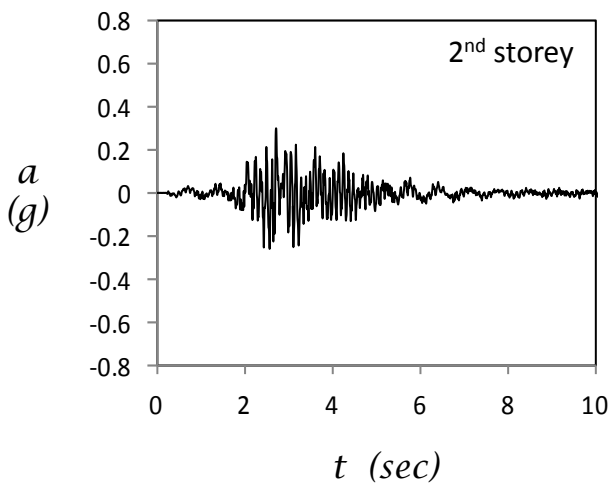
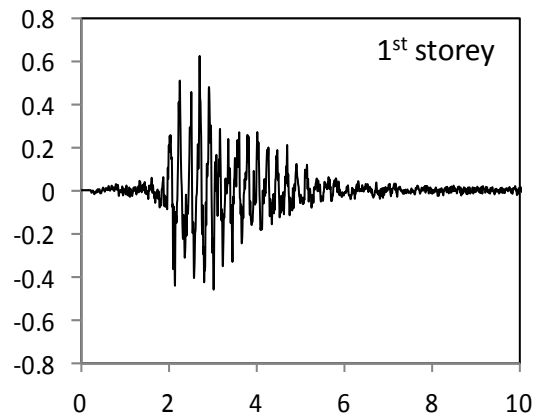
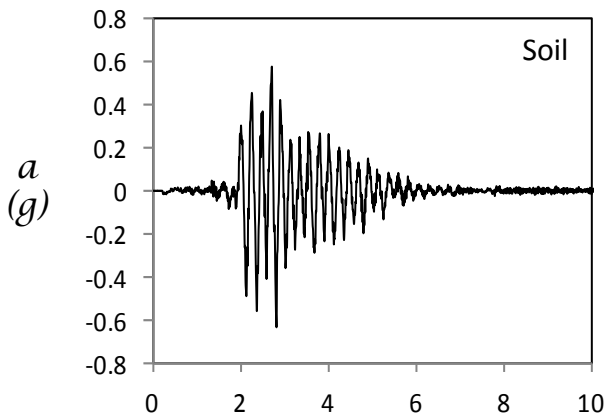
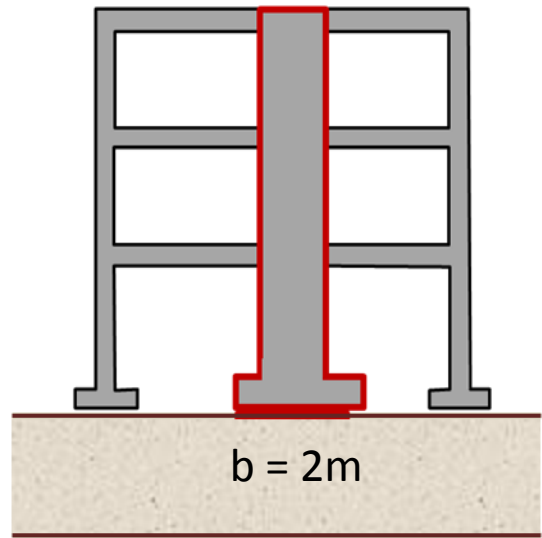
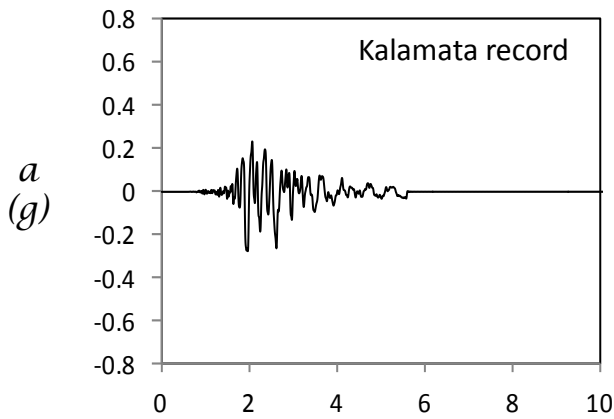

Figure B111. Acceleration time histories measured on the retrofitted building with rocking isolation ($b = 2\text{m}$, $t = 0.10\text{m}$) while submitted to the record of Kalamata.

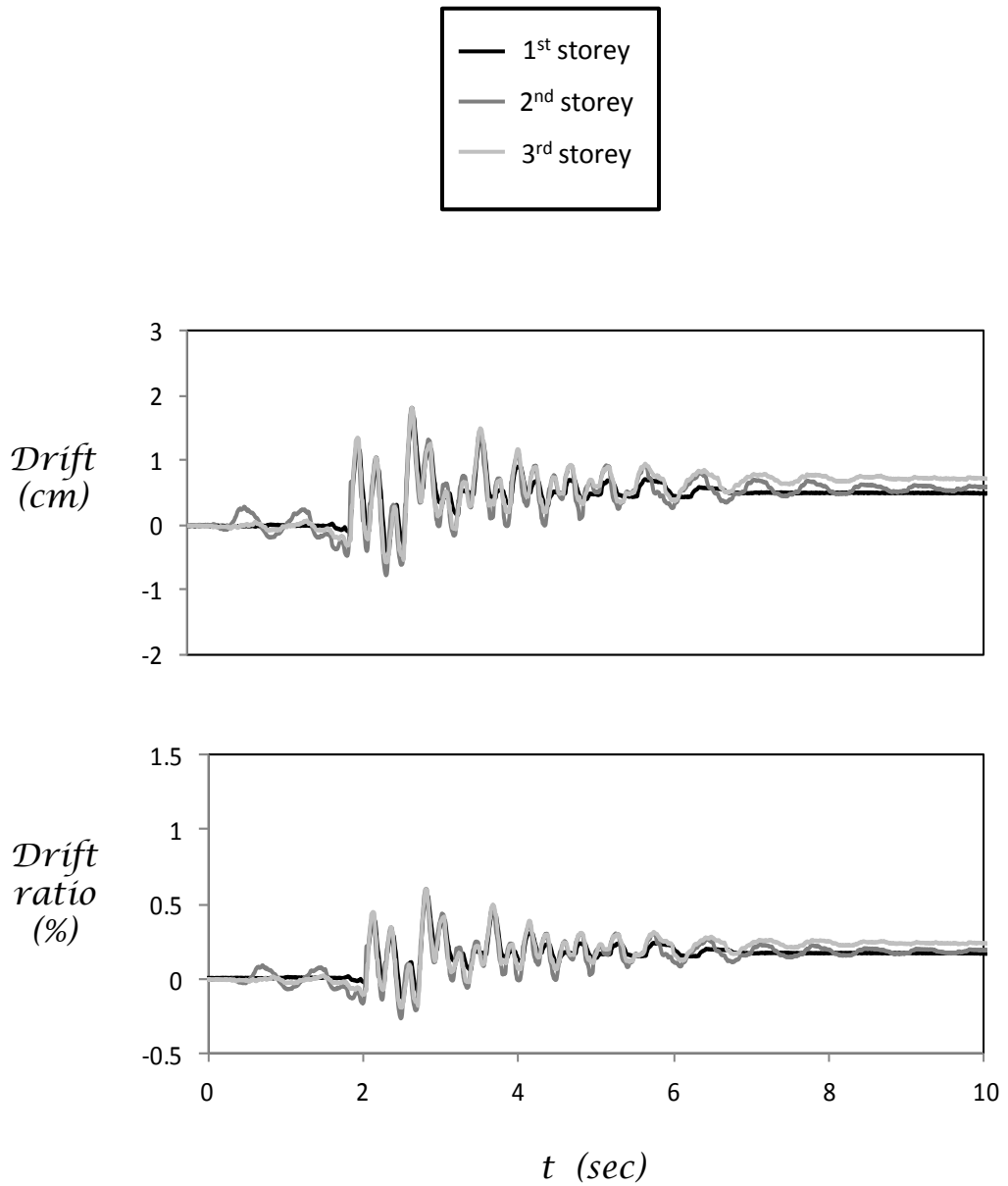

Figure B112. Time histories of storey drift and drift ratio of retrofitted building with rocking isolation ($b = 2\text{m}$, $t = 0.10\text{m}$) while submitted to the record of Kalamata.

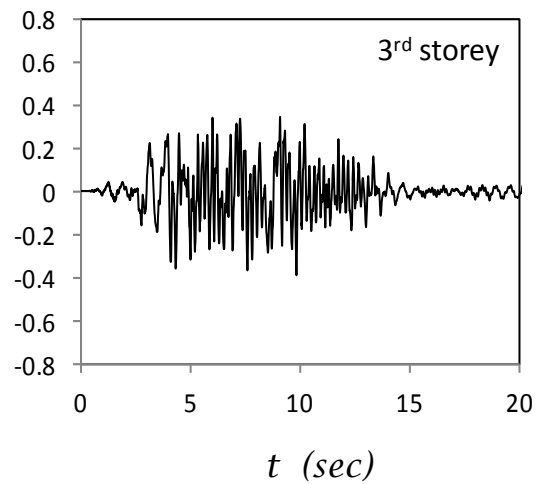
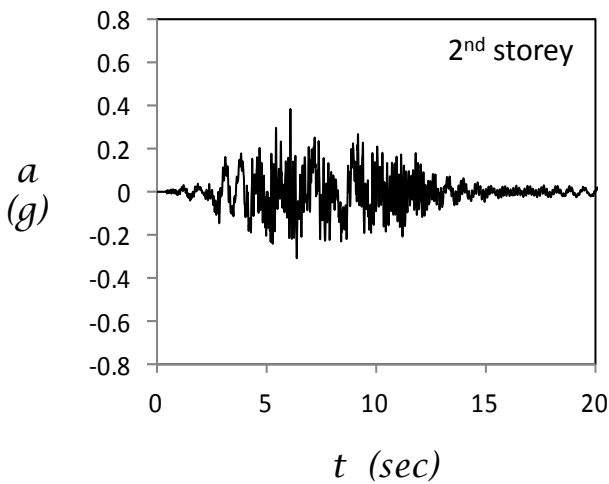
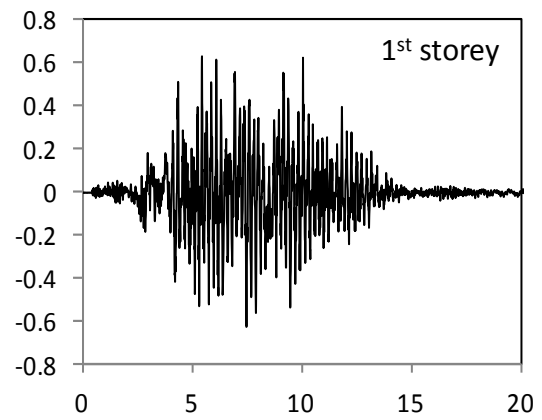
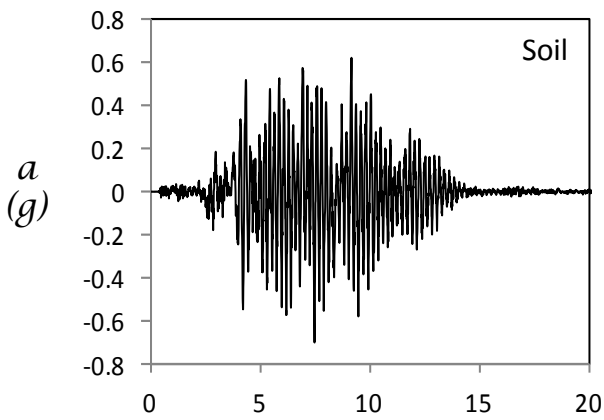
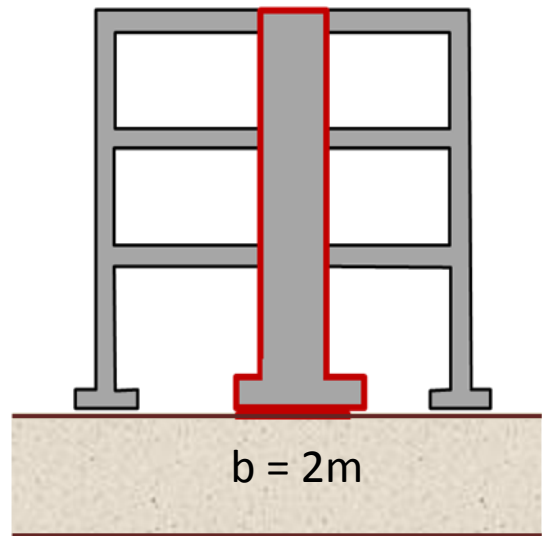
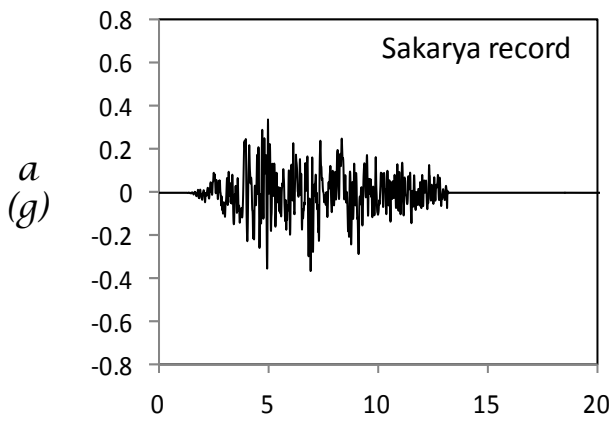

Figure B113. Acceleration time histories measured on the retrofitted building with rocking isolation ($b = 2\text{m}$, $t = 0.10\text{m}$) while submitted to the record of Sakarya.

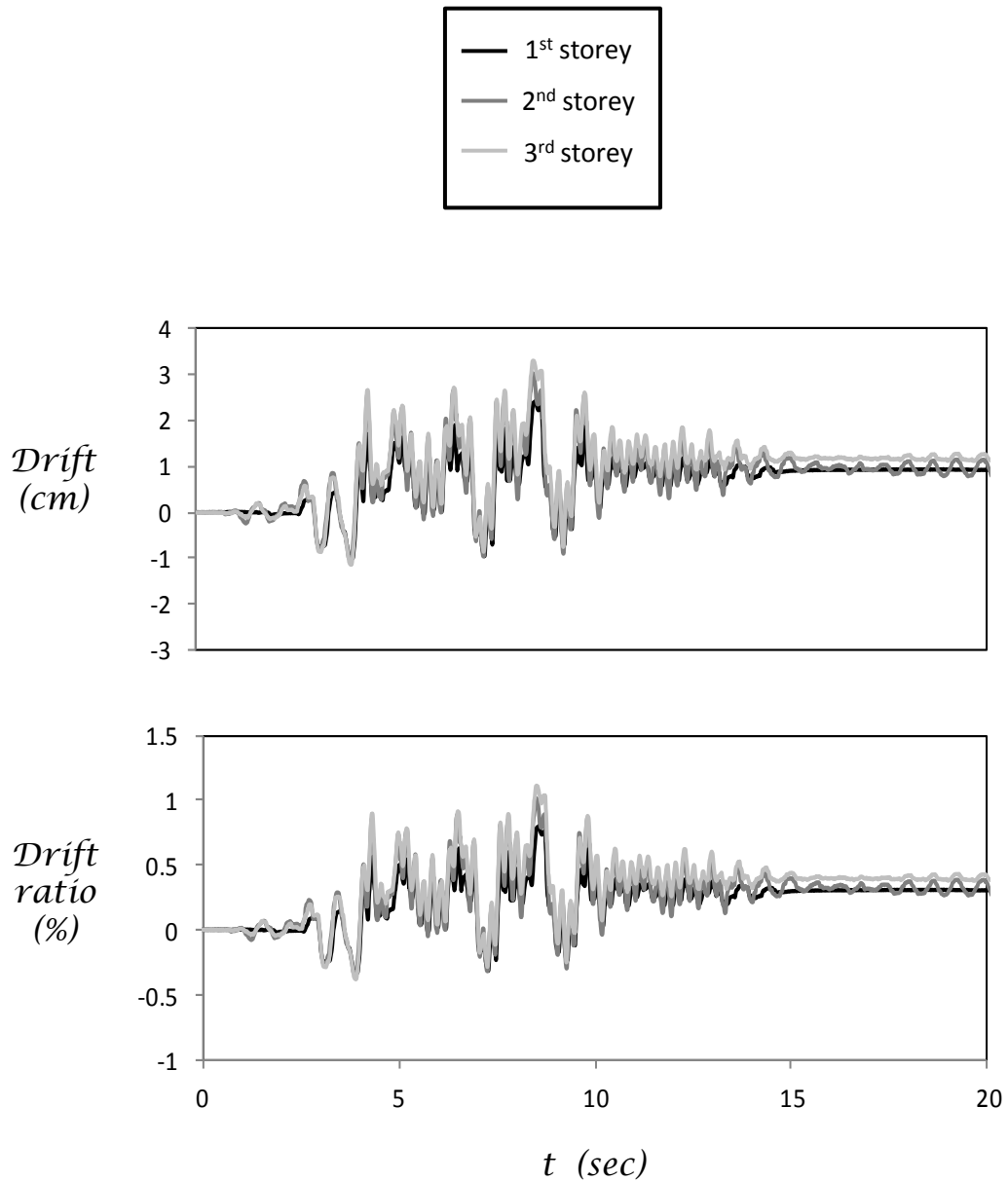

Figure B114. Time histories of storey drift and drift ratio of retrofitted building with rocking isolation ($b = 2\text{m}$, $t = 0.10\text{m}$) while submitted to the record of Sakarya.

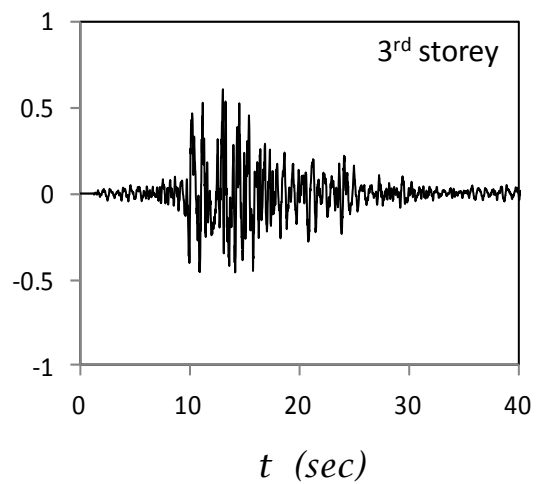
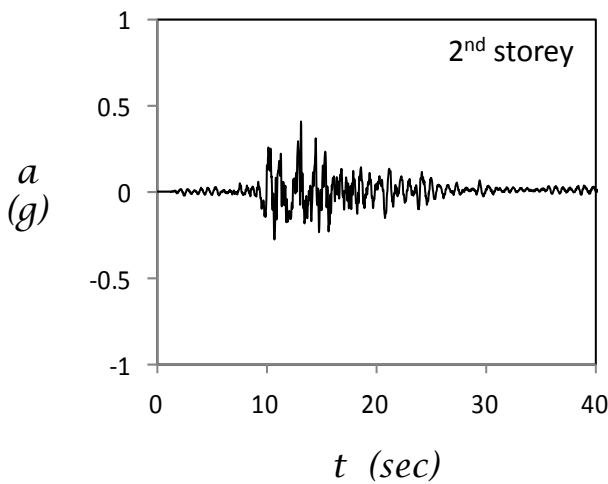
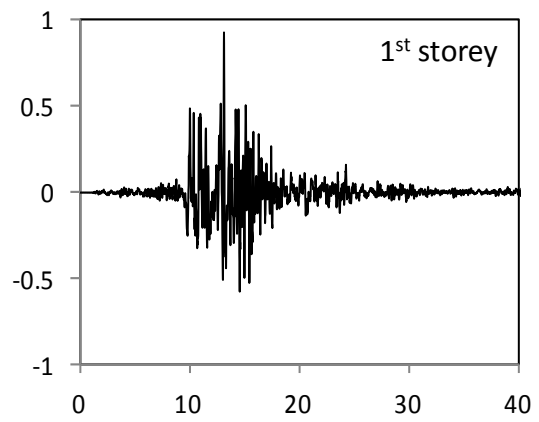
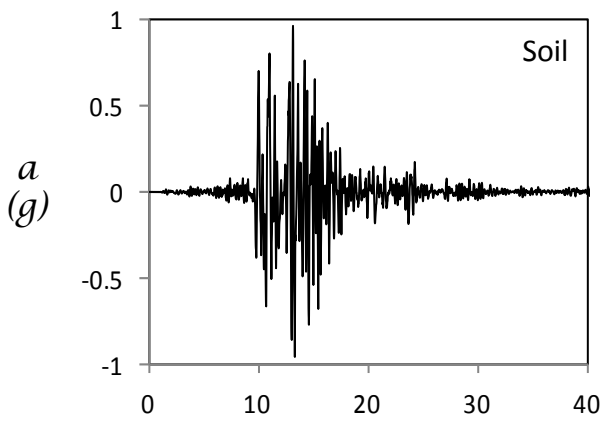
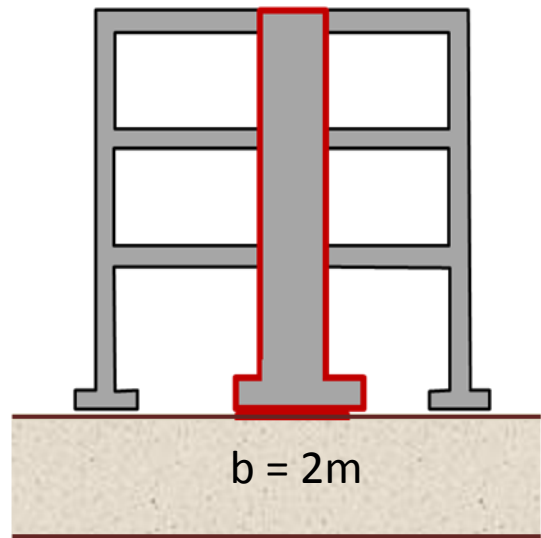
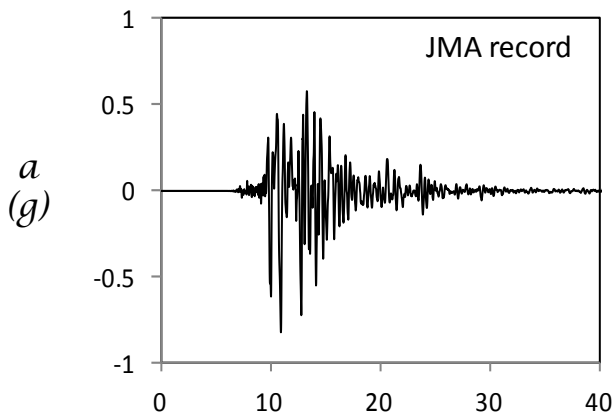

Figure B115. Acceleration time histories measured on the retrofitted building with rocking isolation ($b = 2\text{m}$, $t = 0.10\text{m}$) while submitted to the record of JMA.

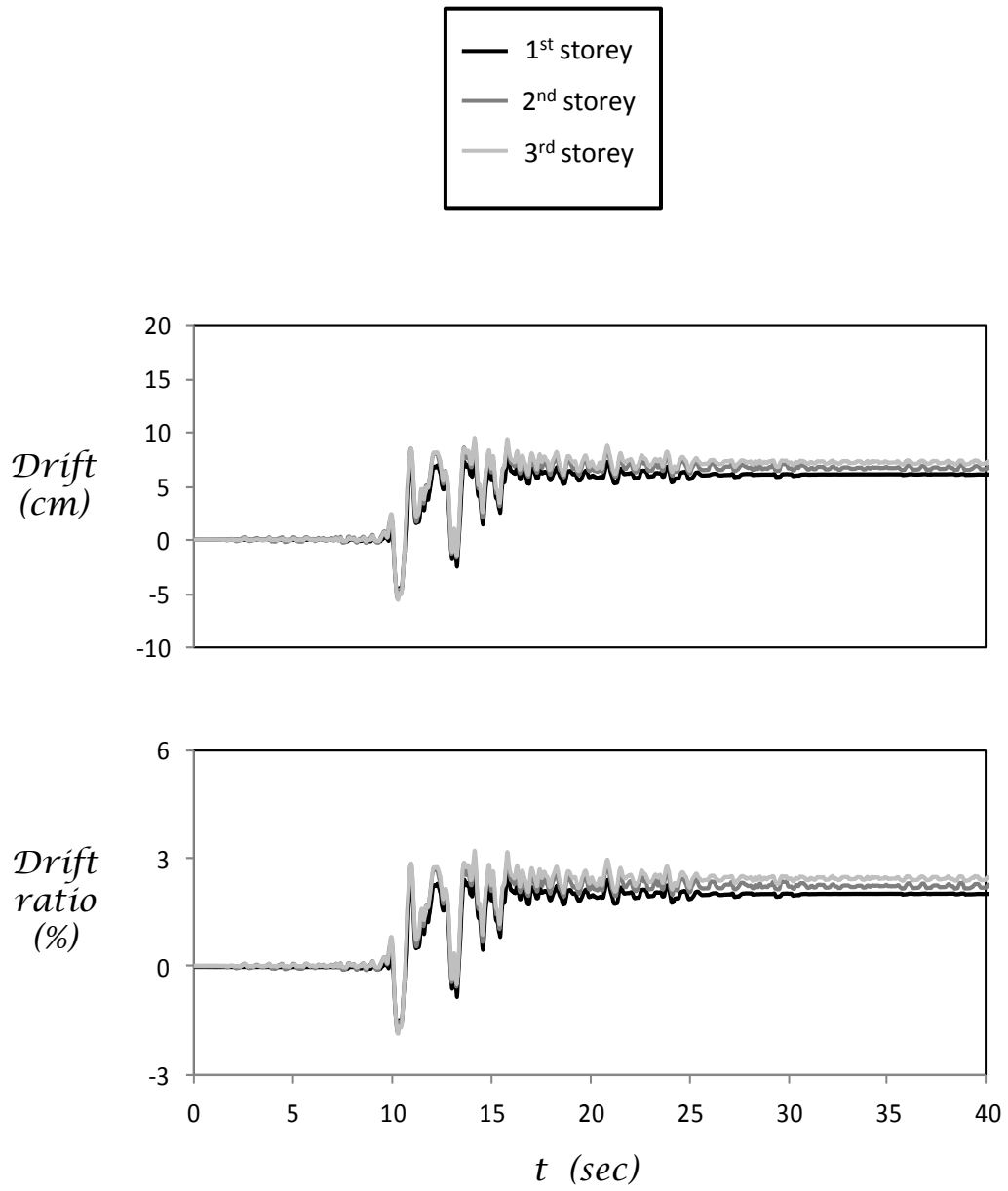

Figure B116. Time histories of storey drift and drift ratio of retrofitted building with rocking isolation ($b = 2\text{m}$, $t = 0.10\text{m}$) while submitted to the record of JMA.

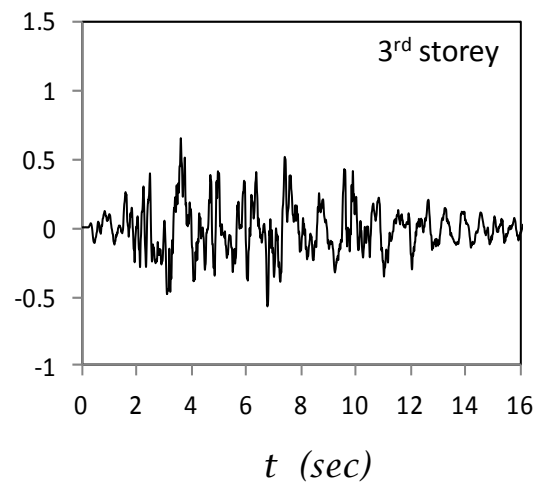
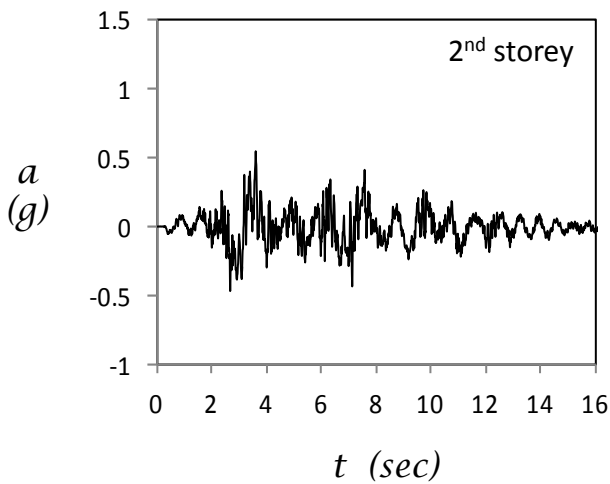
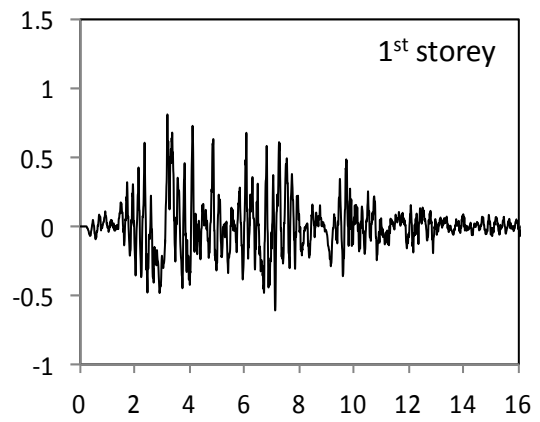
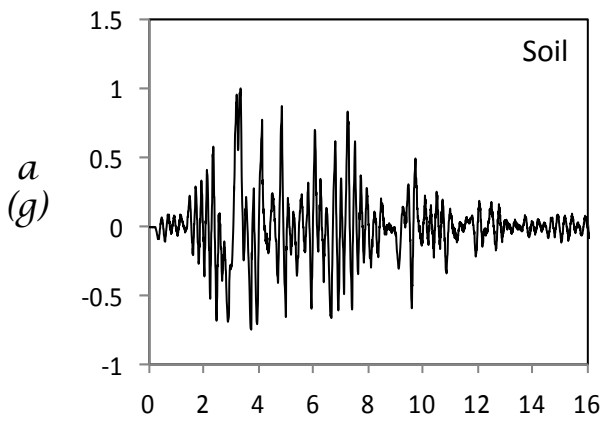
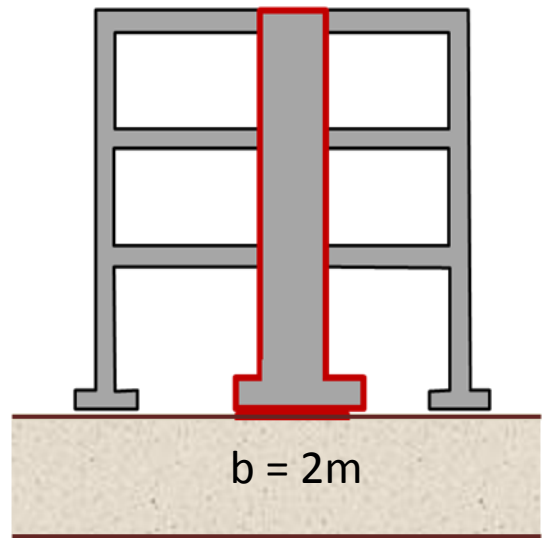
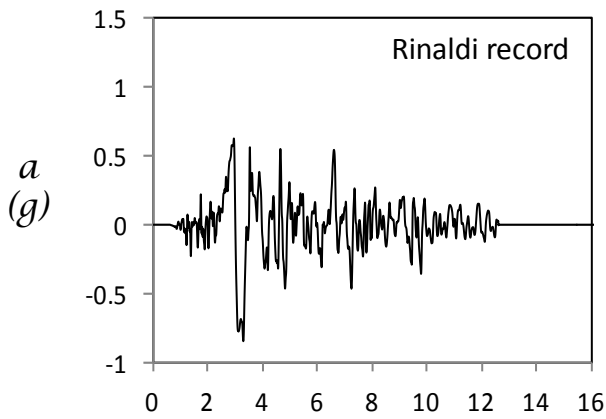

Figure B117. Acceleration time histories measured on the retrofitted building with rocking isolation ($b = 2\text{m}$, $t = 0.10\text{m}$) while submitted to the record of Rinaldi.

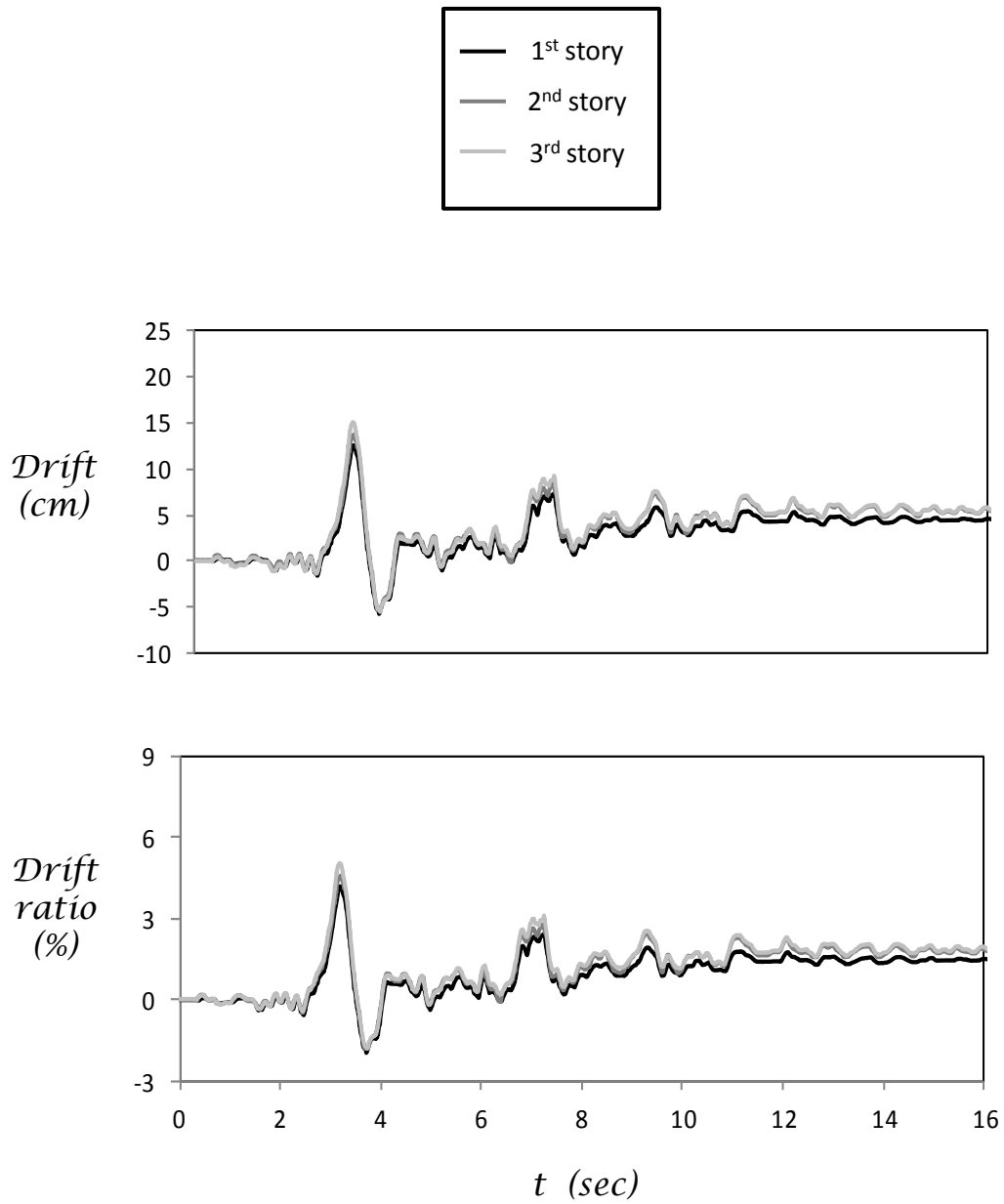

Figure B118. Time histories of storey drift and drift ratio of retrofitted building with rocking isolation ($b = 2\text{m}$, $t = 0.10\text{m}$) while submitted to the record of Rinaldi.

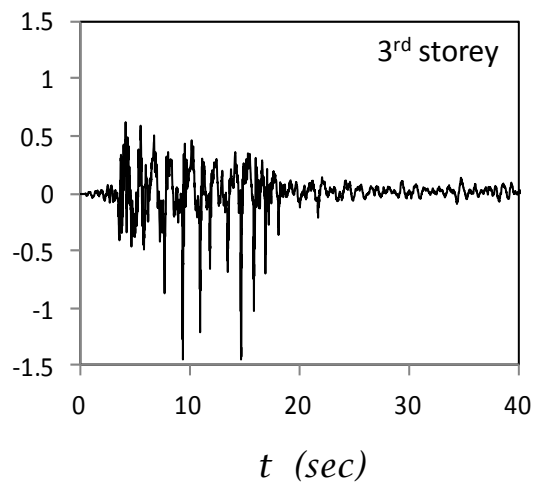
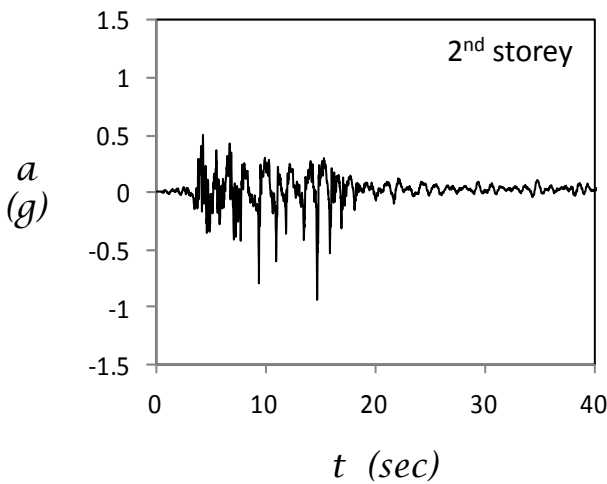
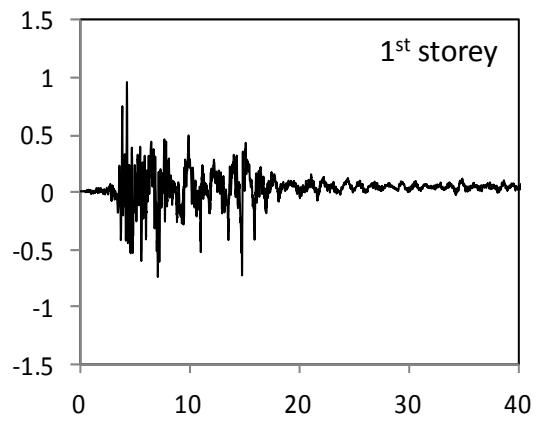
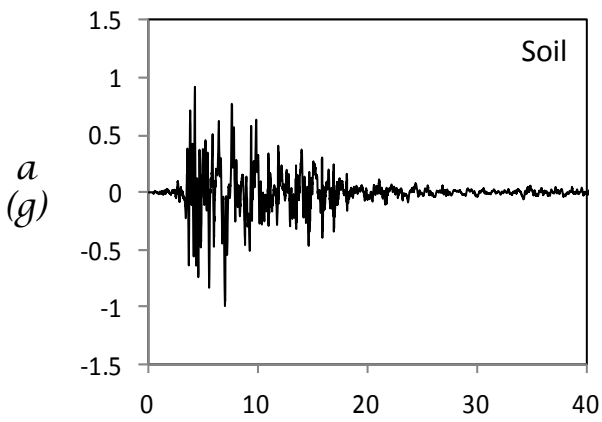
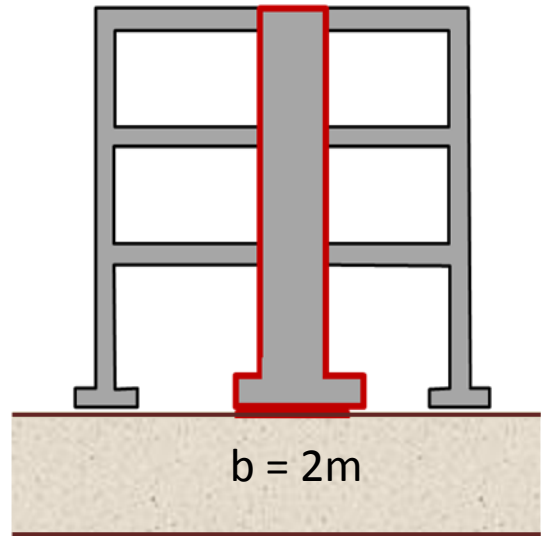
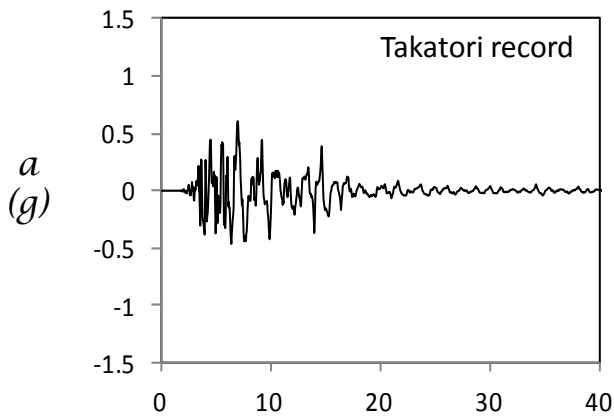

Figure B119. Acceleration time histories measured on the retrofitted building with rocking isolation ($b = 2\text{m}$, $t = 0.10\text{m}$) while submitted to the record of Takatori.

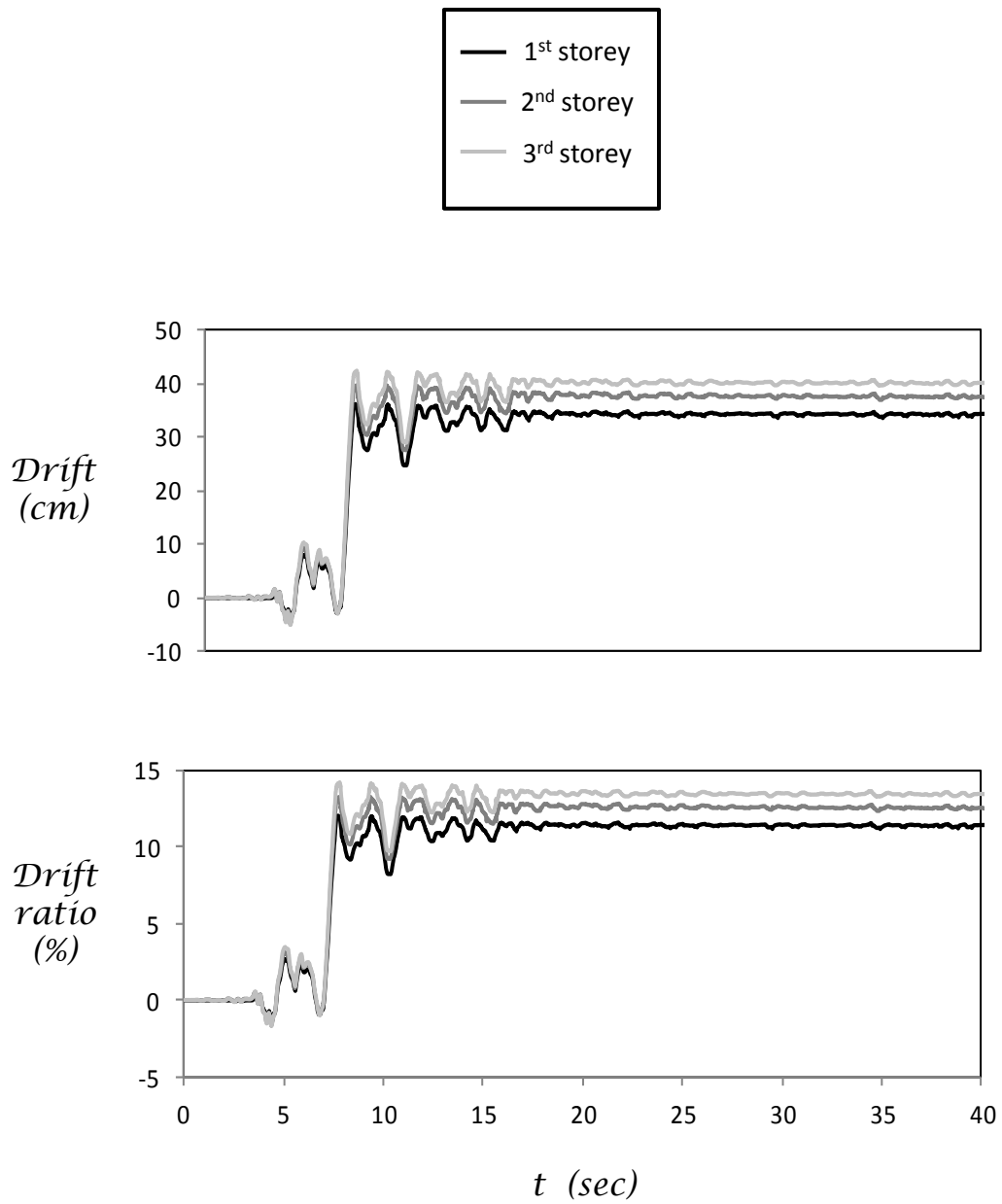

Figure B120. Time histories of storey drift and drift ratio of retrofitted building with rocking isolation ($b = 2\text{m}$, $t = 0.10\text{m}$) while submitted to the record of Takatori.

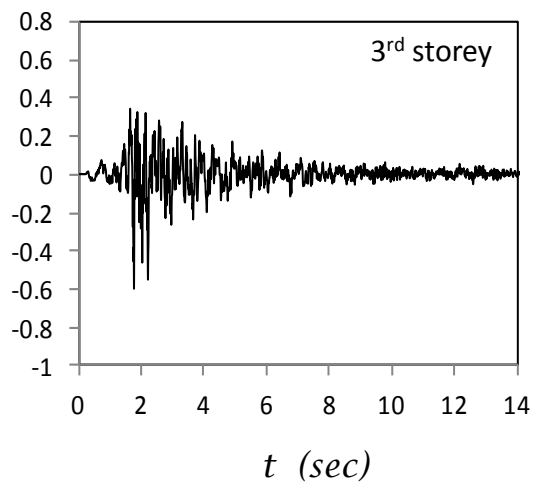
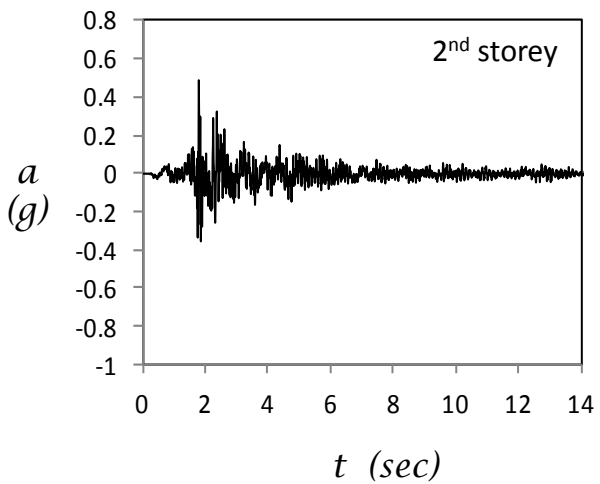
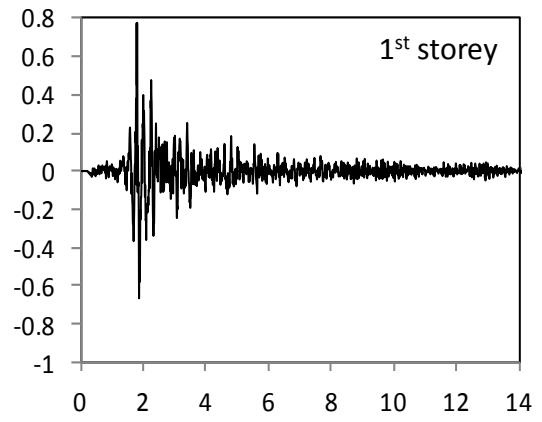
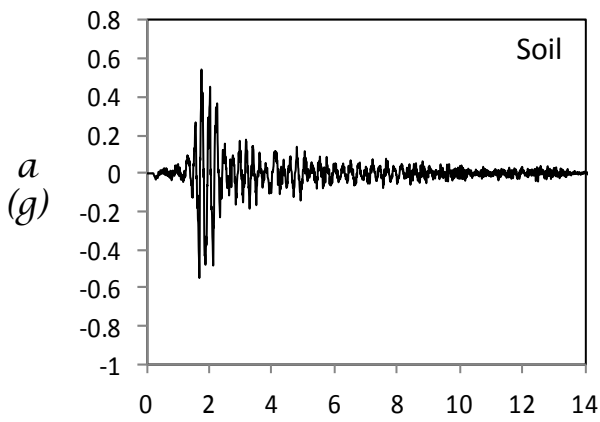
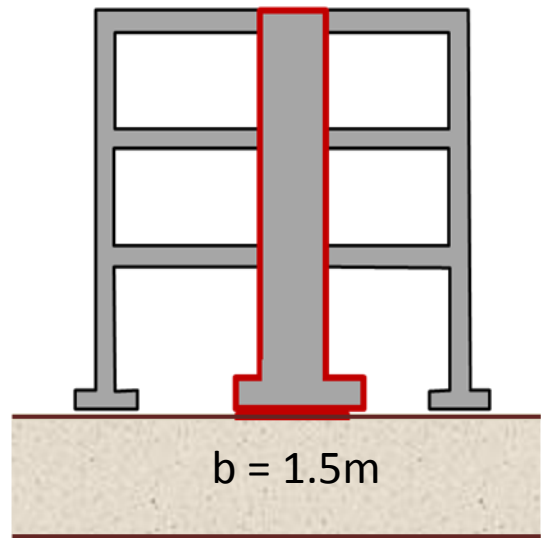
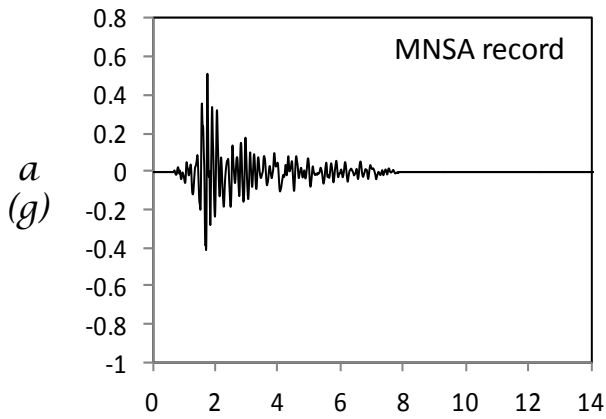

Figure B121. Acceleration time histories measured on the retrofitted building with rocking isolation ($b = 1.5\text{m}$, $t = 0.05\text{m}$) while submitted to the record of MNSA.

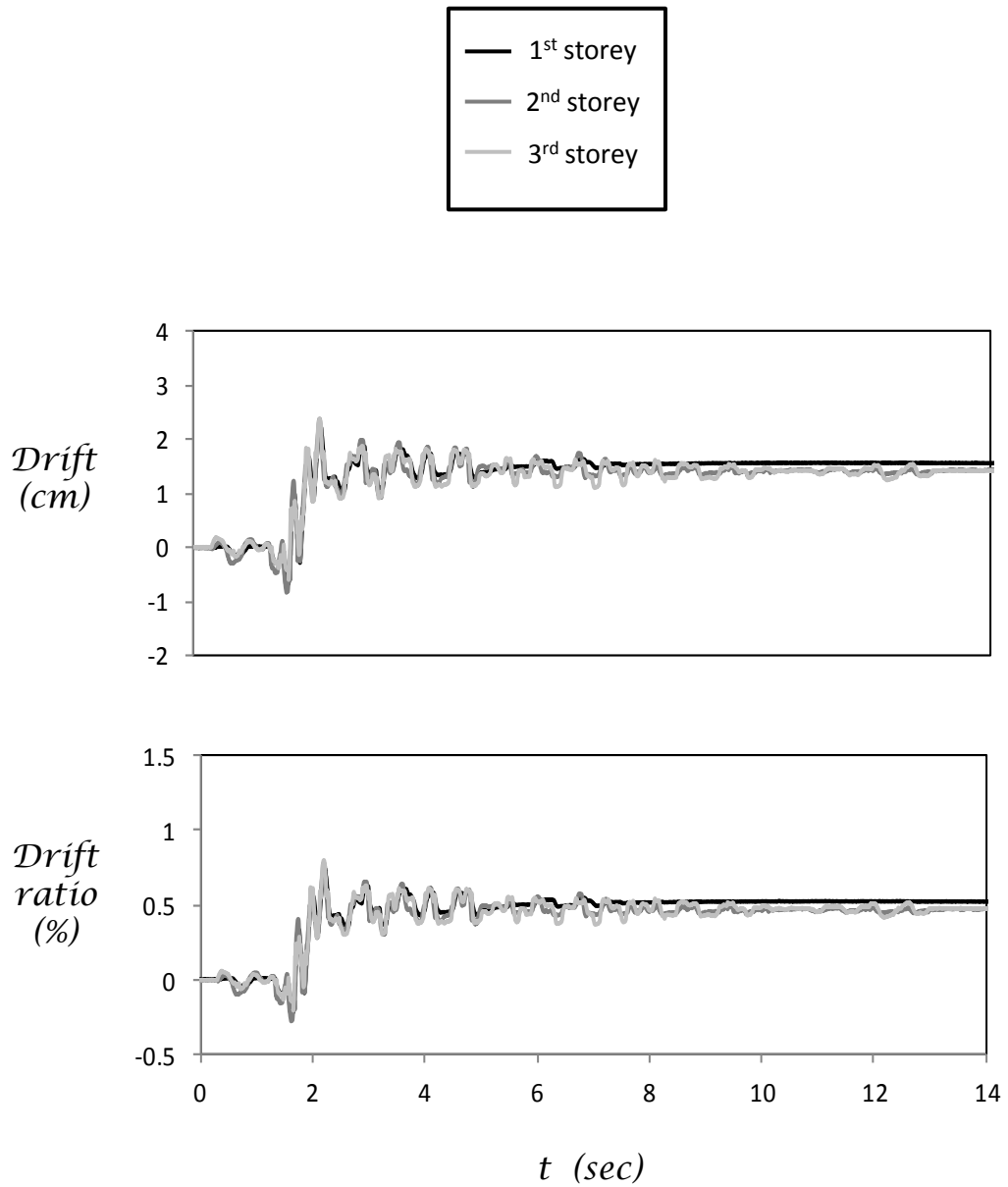

Figure B122. Time histories of storey drift and drift ratio of retrofitted building with rocking isolation ($b = 1.5\text{m}$, $t = 0.05\text{m}$) while submitted to the record of MNSA.

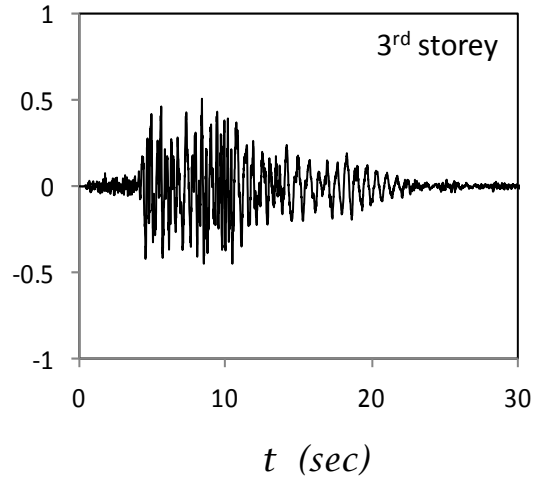
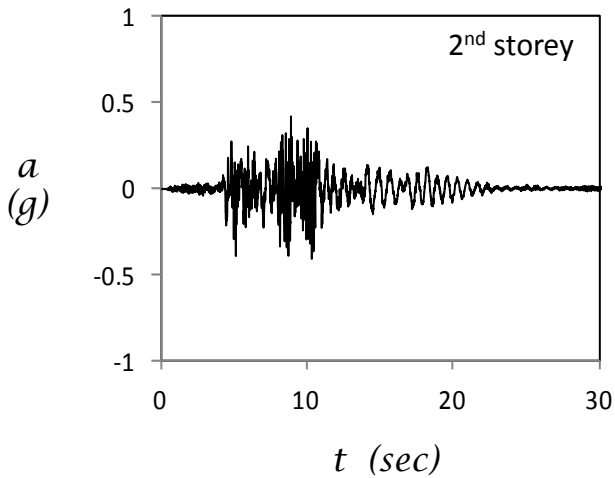
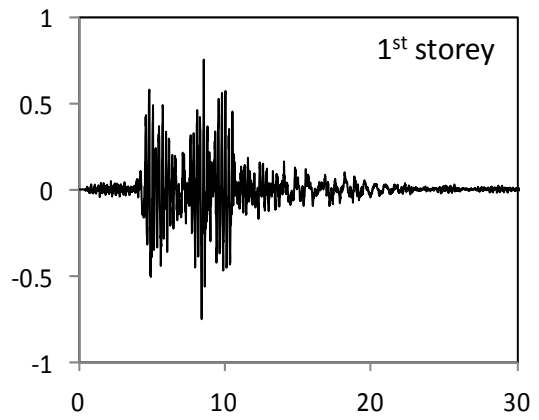
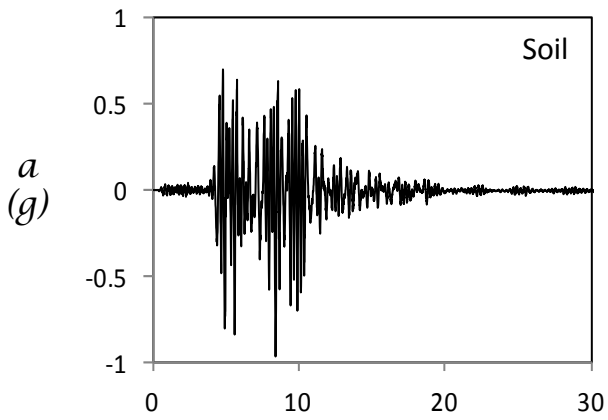
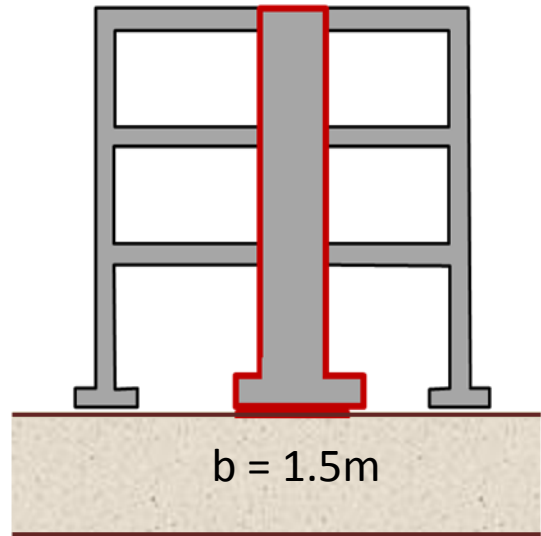
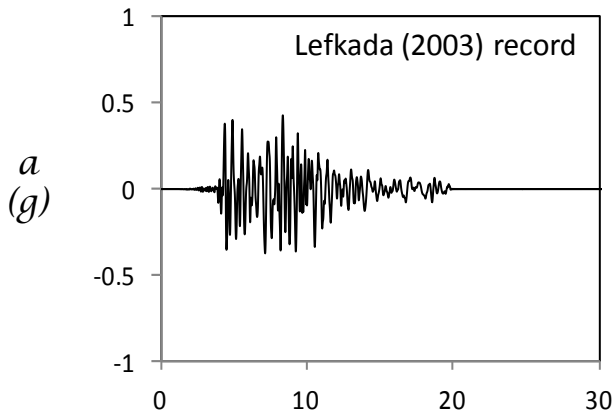

Figure B123. Acceleration time histories measured on the retrofitted building with rocking isolation ($b = 1.5\text{m}$, $t = 0.05\text{m}$) while submitted to the record of Lefkada (2003).

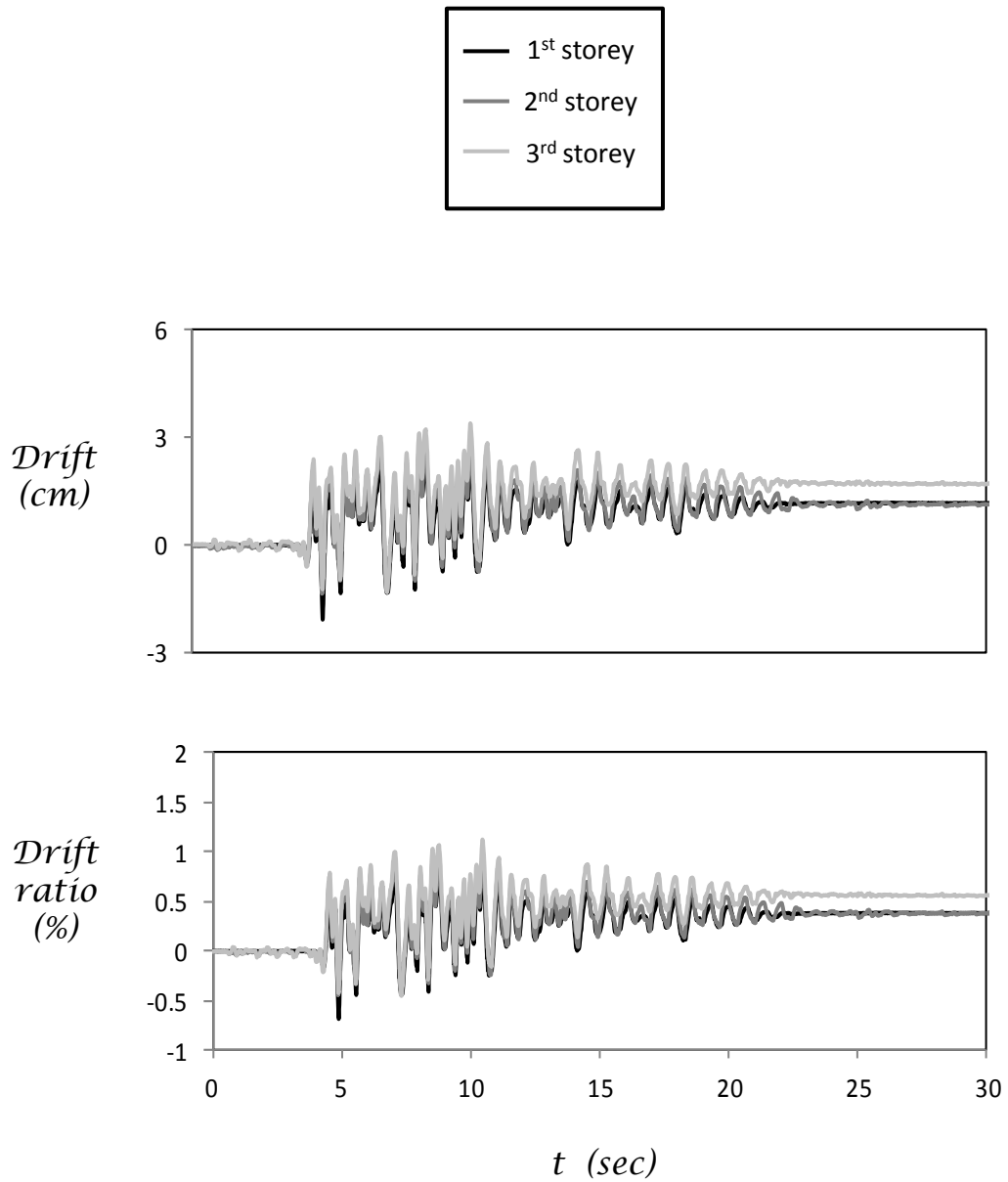

Figure B124. Time histories of storey drift and drift ratio of retrofitted building with rocking isolation ($b = 1.5\text{m}$, $t = 0.05\text{m}$) while submitted to the record of Lefkada (2003).

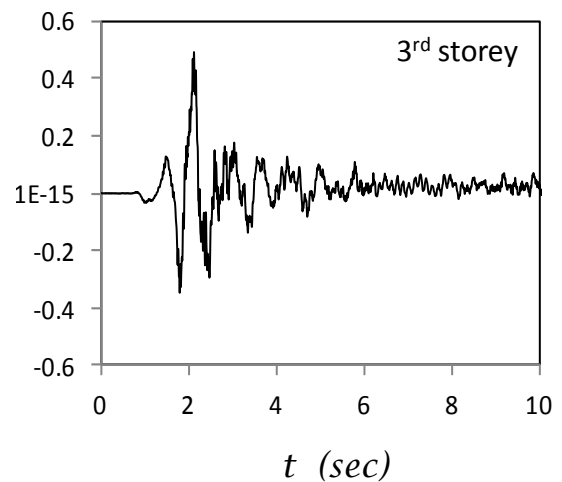
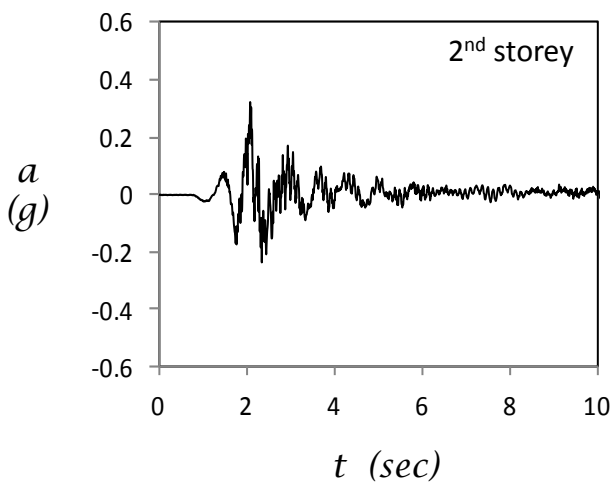
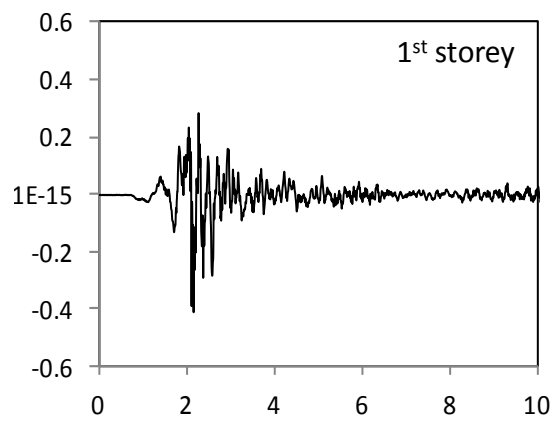
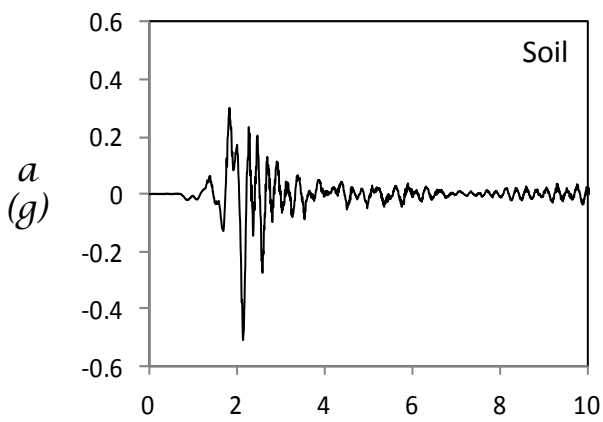
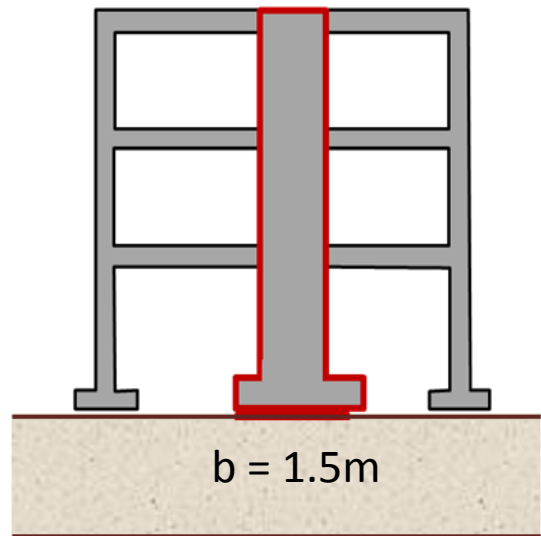
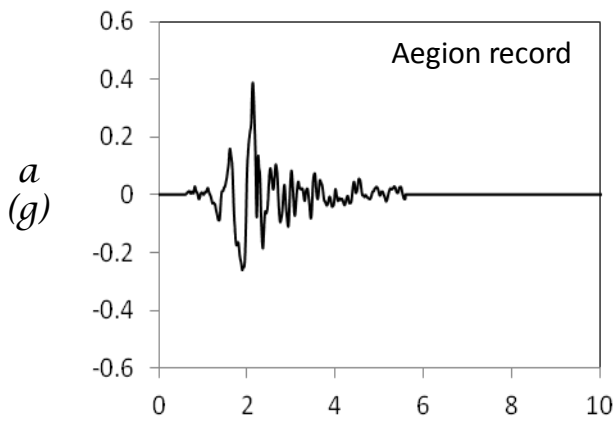

Figure B125. Acceleration time histories measured on the retrofitted building with rocking isolation ($b = 1.5\text{m}$, $t = 0.05\text{m}$) while submitted to the record of Aegion.

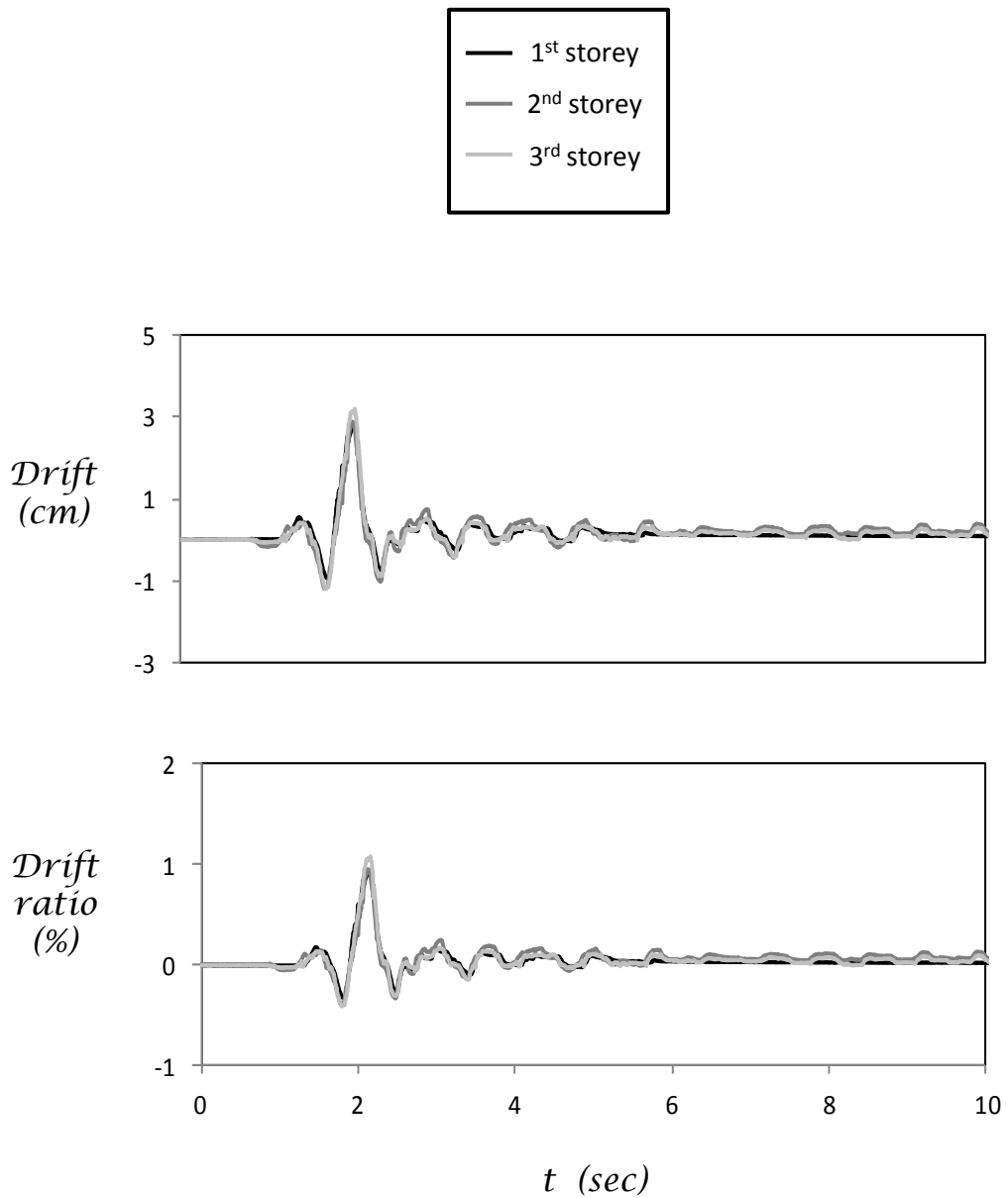

Figure B126. Time histories of storey drift and drift ratio of retrofitted building with rocking isolation ($b = 1.5\text{m}$, $t = 0.05\text{m}$) while submitted to the record of Aegion.

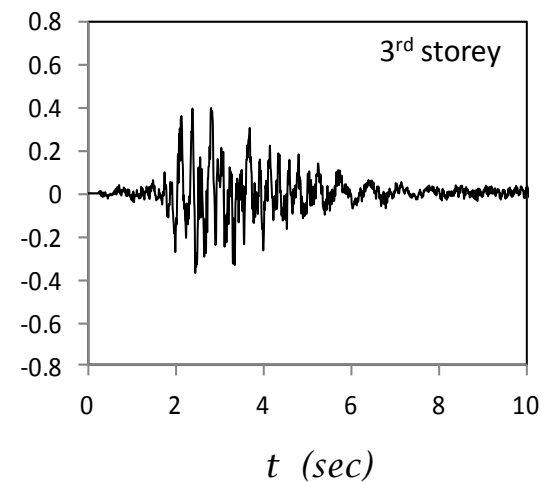
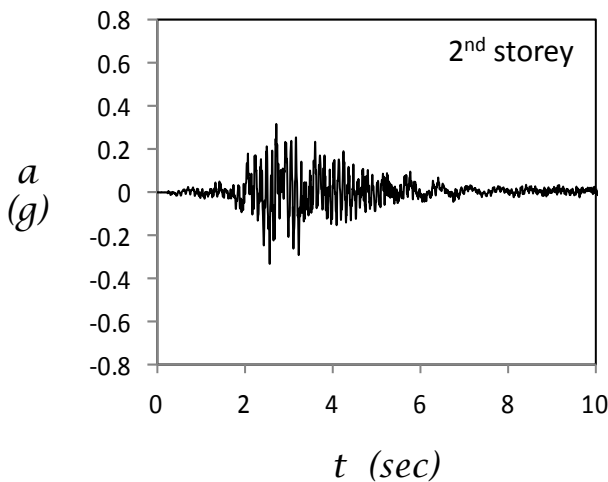
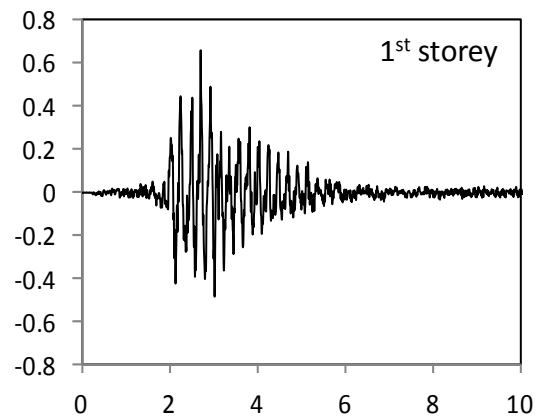
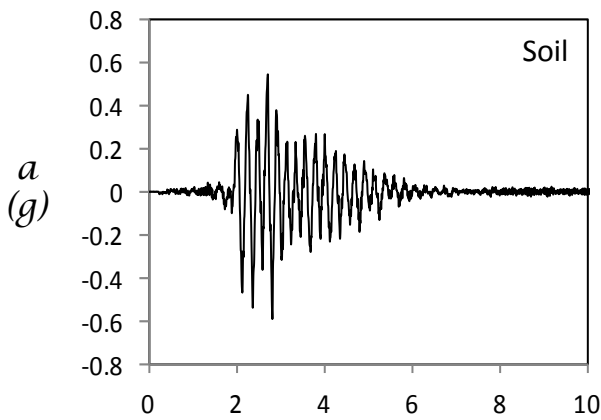
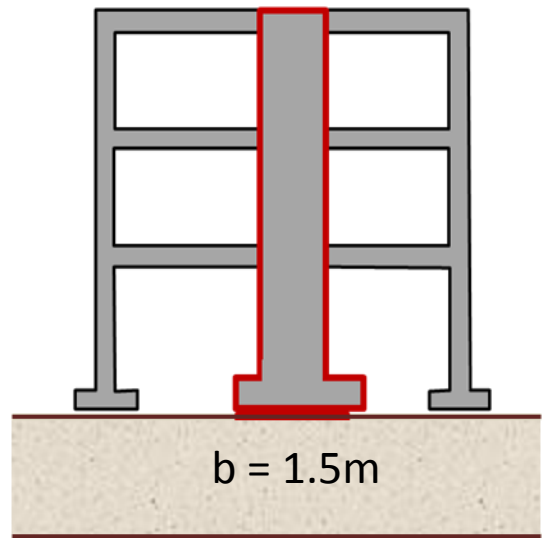
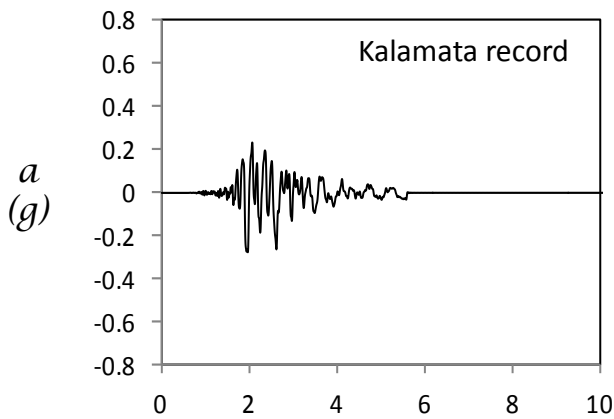

Figure B127. Acceleration time histories measured on the retrofitted building with rocking isolation ($b = 1.5\text{m}$, $t = 0.05\text{m}$) while submitted to the record of Kalamata.

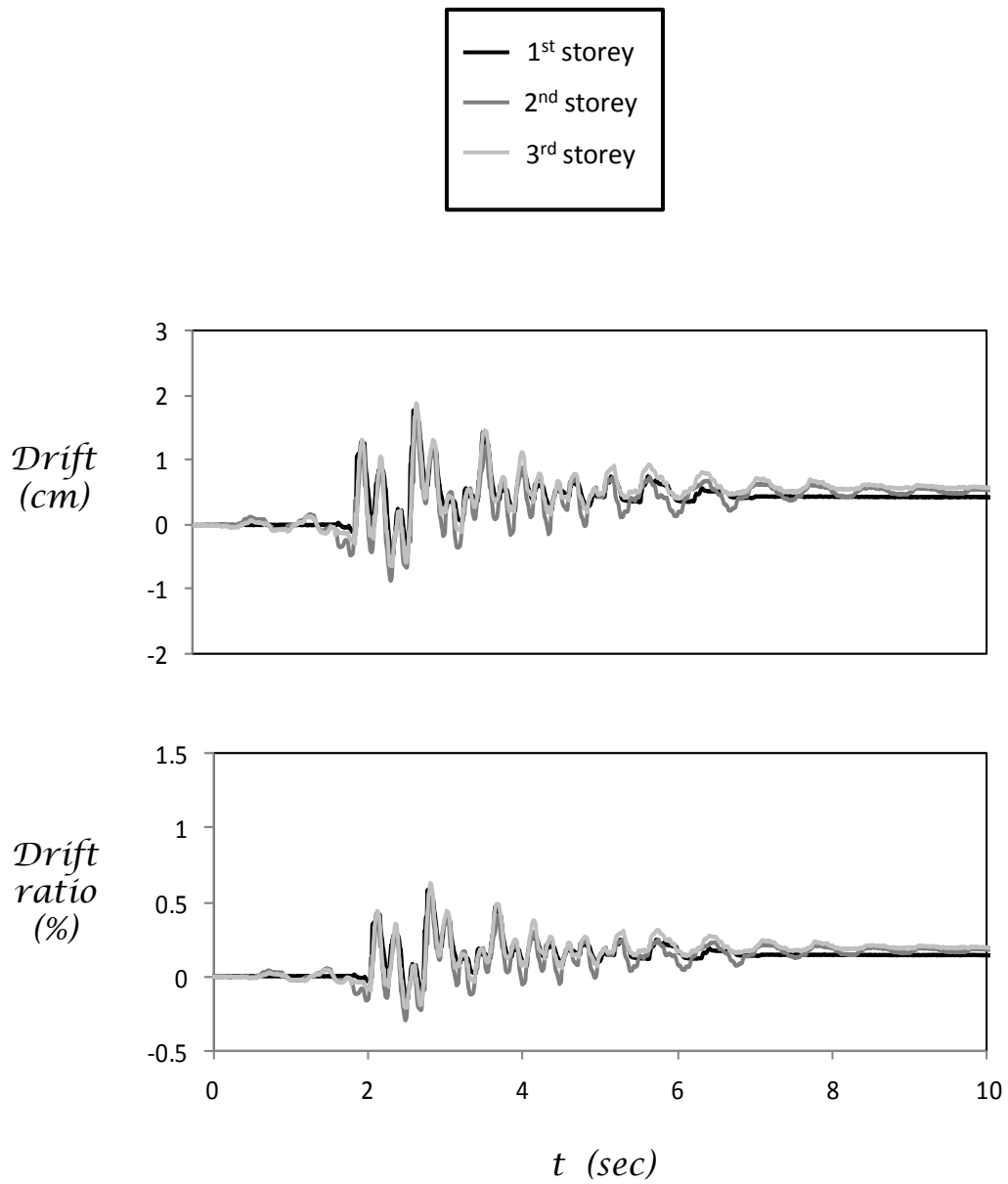
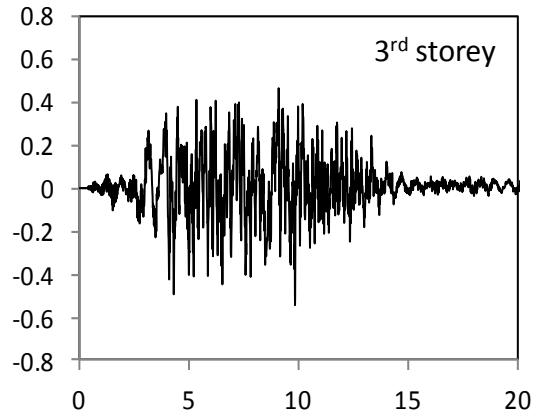
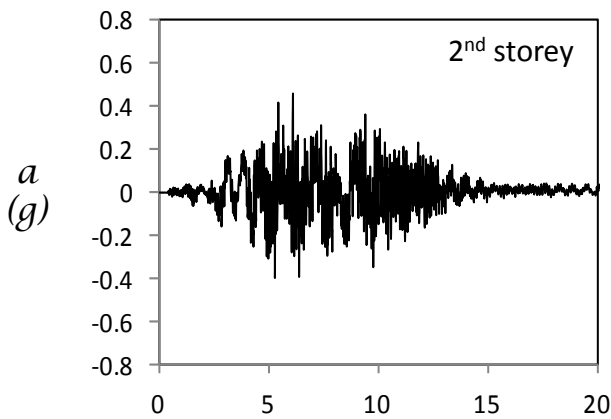
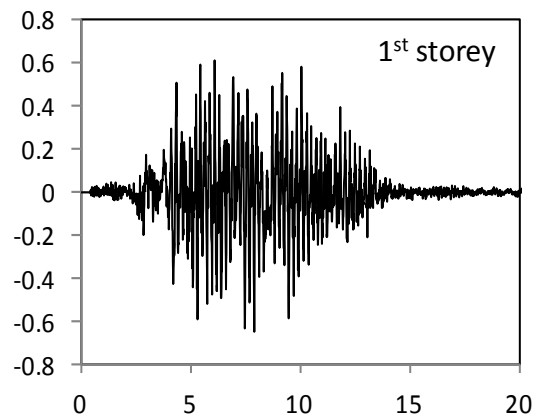
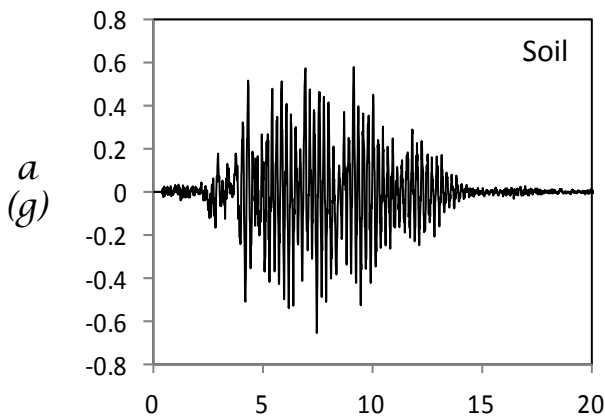
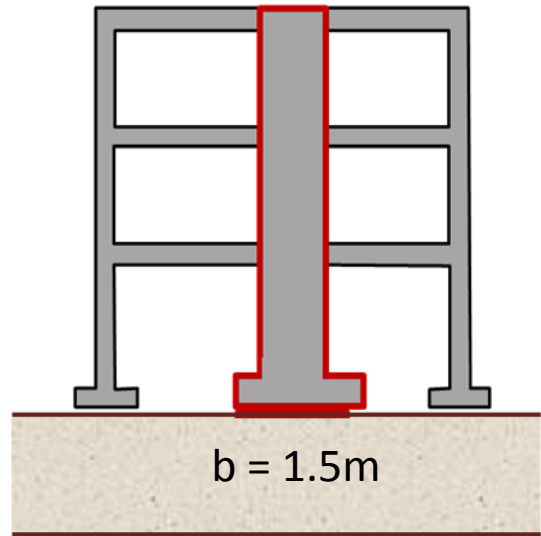
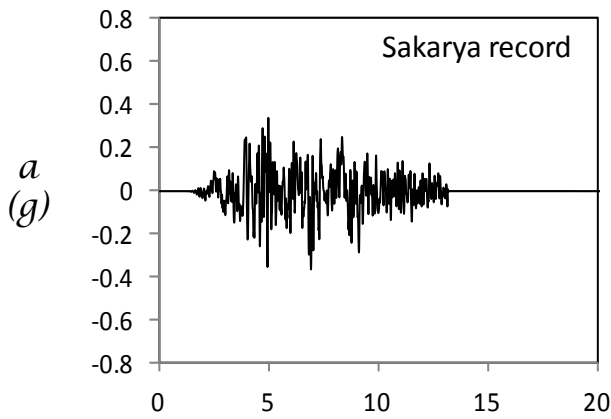

Figure B128. Time histories of storey drift and drift ratio of retrofitted building with rocking isolation ($b = 1.5\text{m}$, $t = 0.05\text{m}$) while submitted to the record of Kalamata.



t (sec)

t (sec)

Figure B129. Acceleration time histories measured on the retrofitted building with rocking isolation ($b = 1.5\text{m}$, $t = 0.05\text{m}$) while submitted to the record of Sakarya.

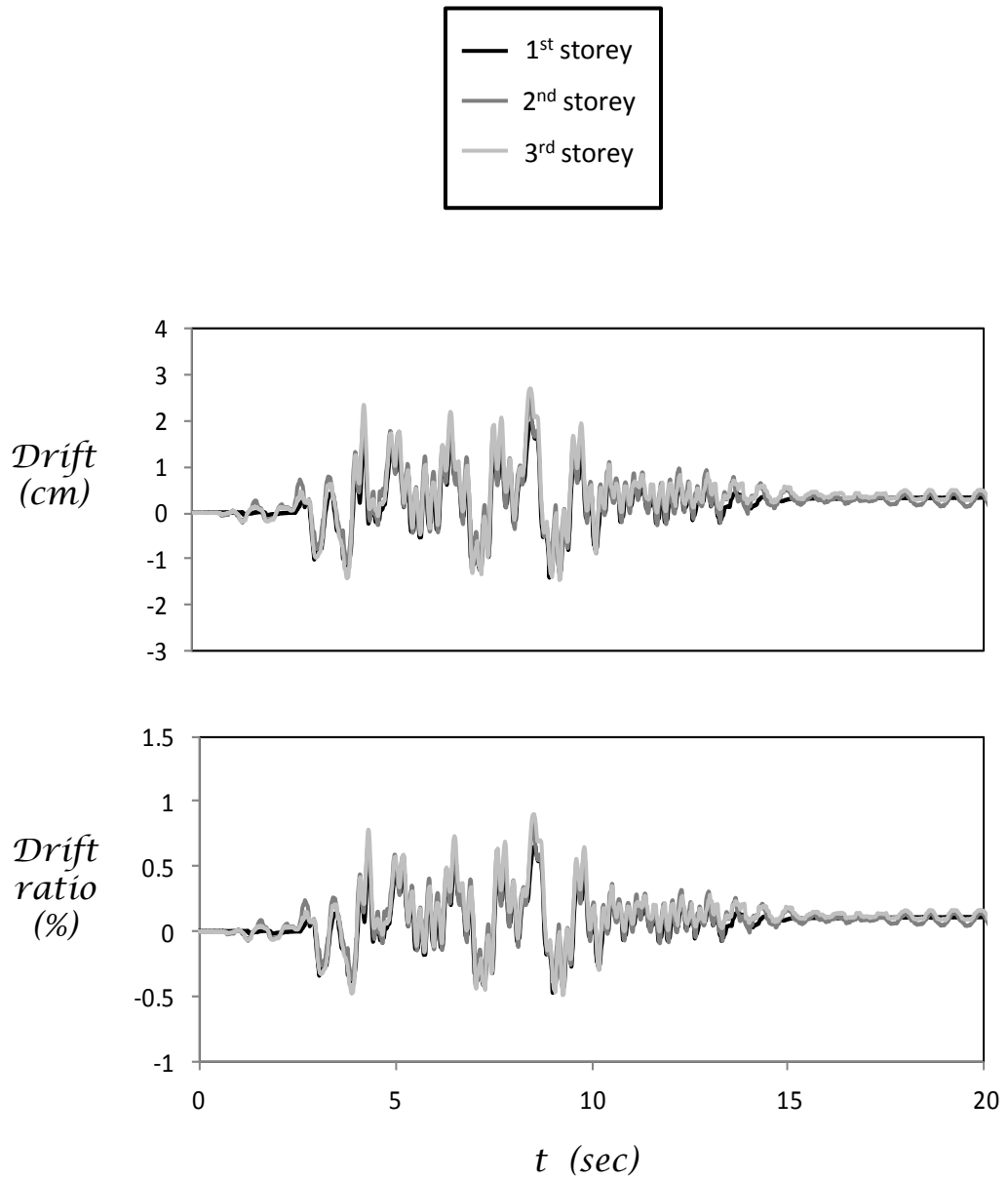
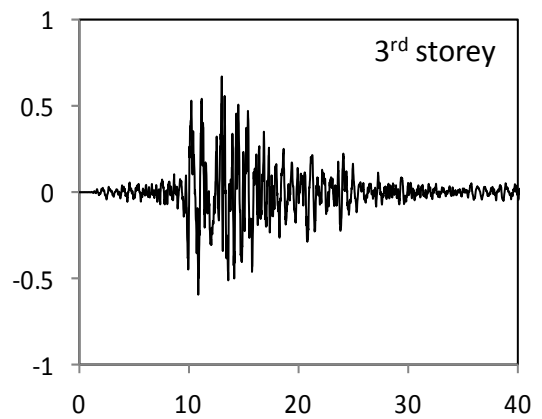
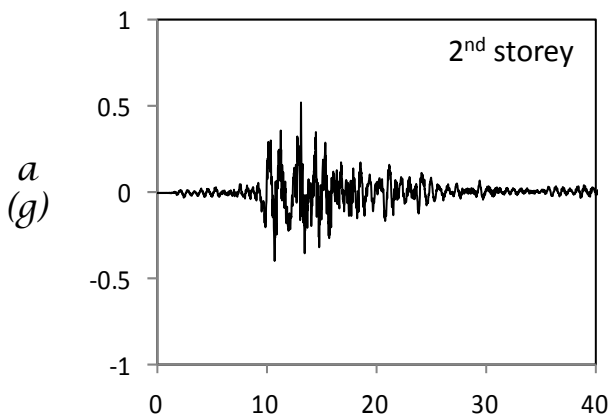
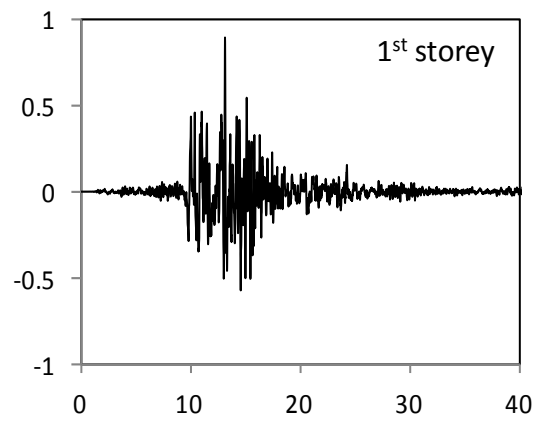
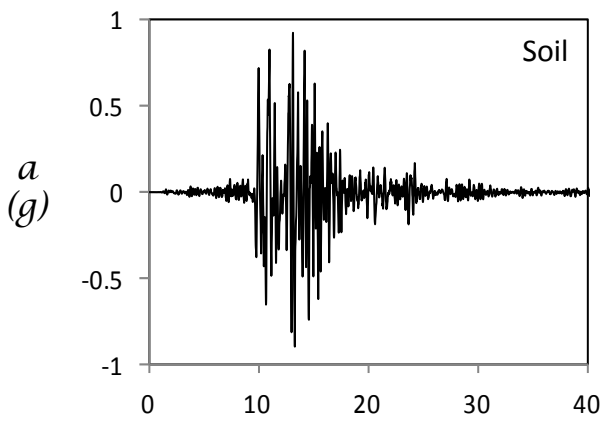
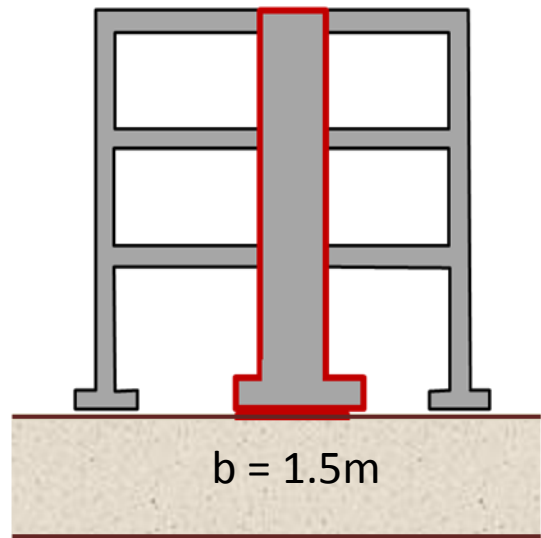
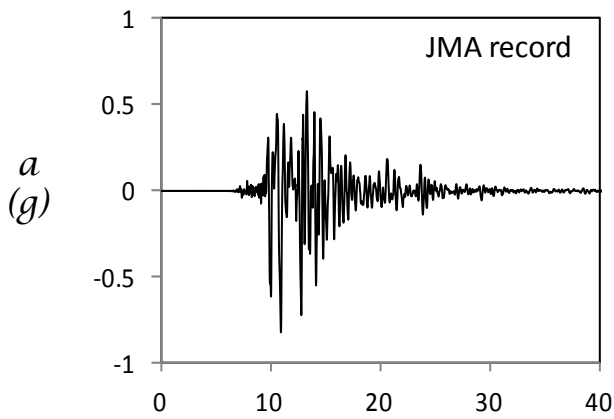

Figure B130. Time histories of storey drift and drift ratio of retrofitted building with rocking isolation ($b = 1.5\text{m}$, $t = 0.05\text{m}$) while submitted to the record of Sakarya.



$t \text{ (sec)}$

$t \text{ (sec)}$

Figure B131. Acceleration time histories measured on the retrofitted building with rocking isolation ($b = 1.5\text{m}$, $t = 0.05\text{m}$) while submitted to the record of JMA.

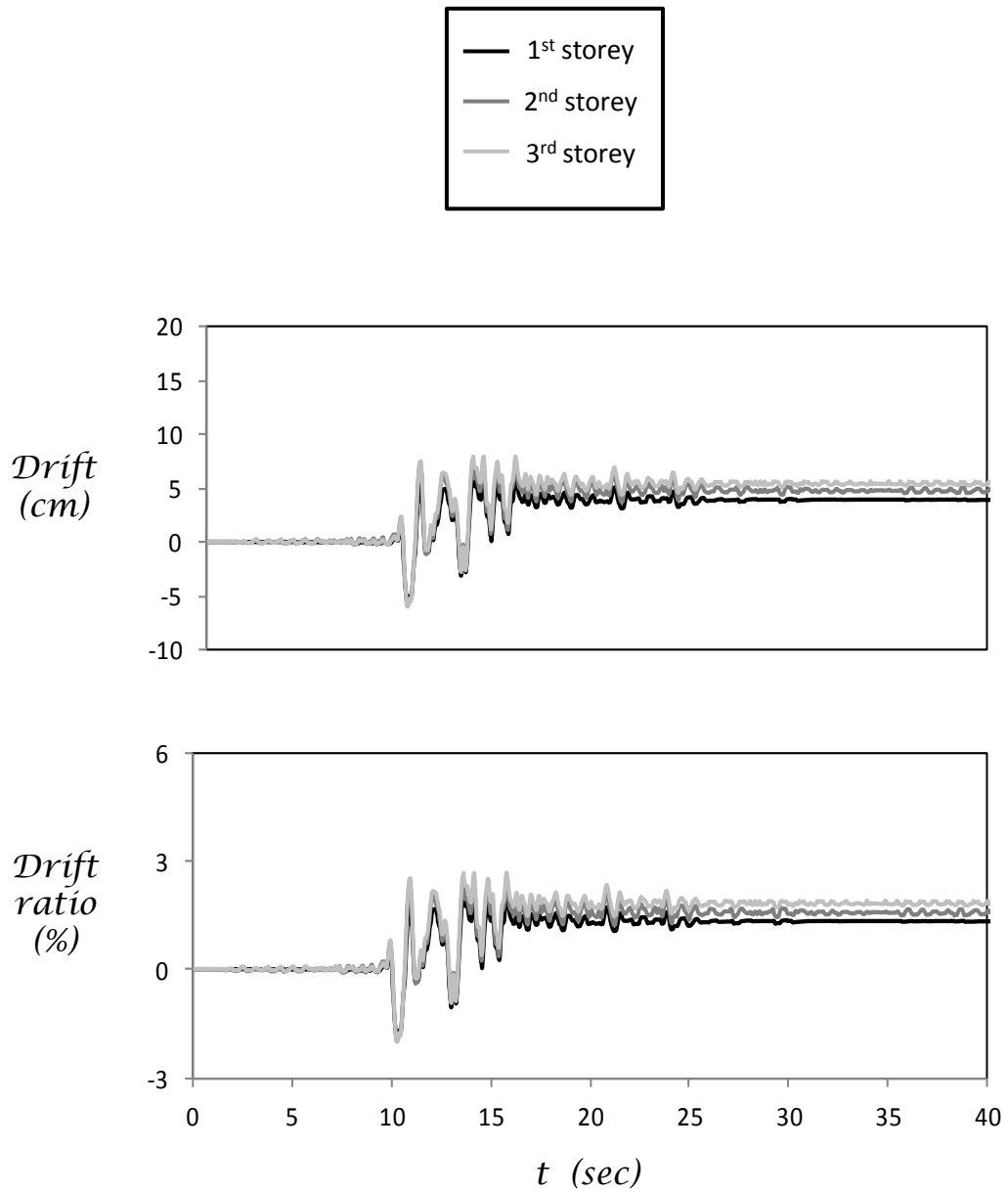

Figure B132. Time histories of storey drift and drift ratio of retrofitted building with rocking isolation ($b = 1.5\text{m}$, $t = 0.05\text{m}$) while submitted to the record of JMA.

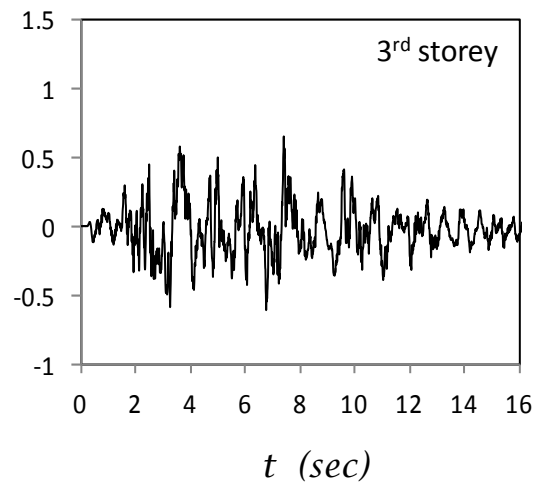
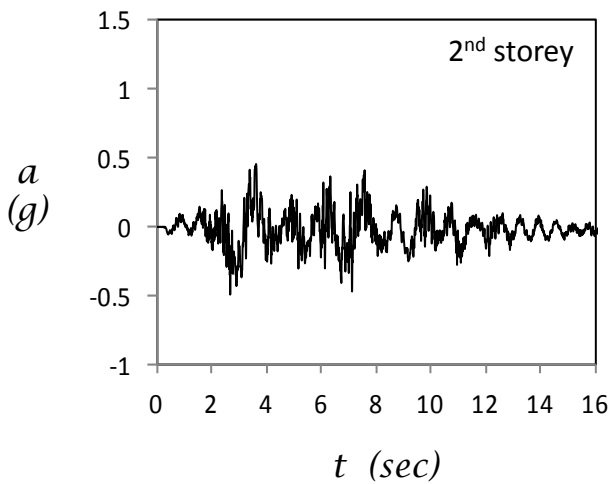
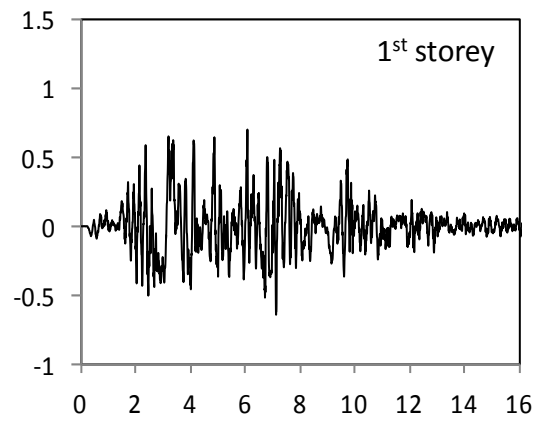
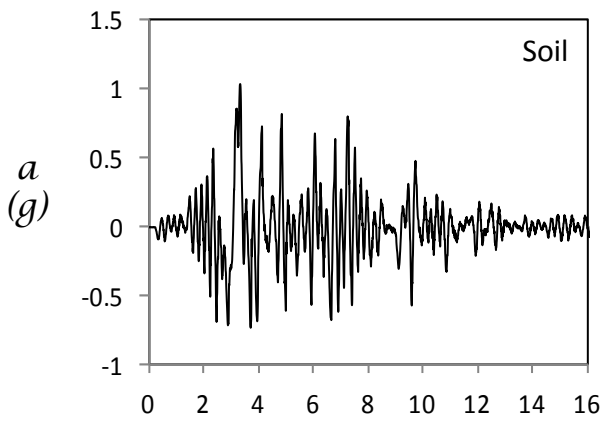
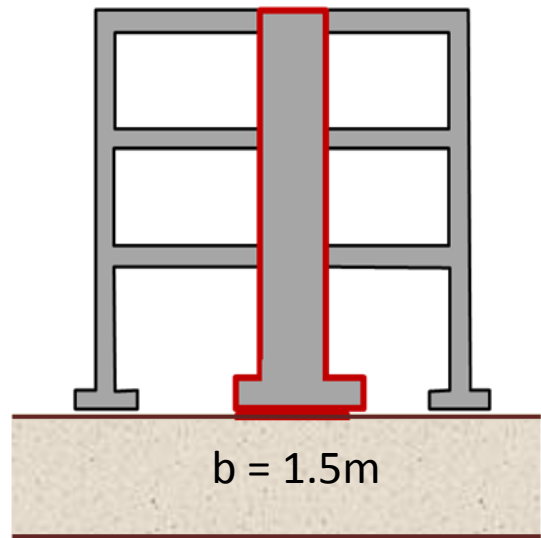
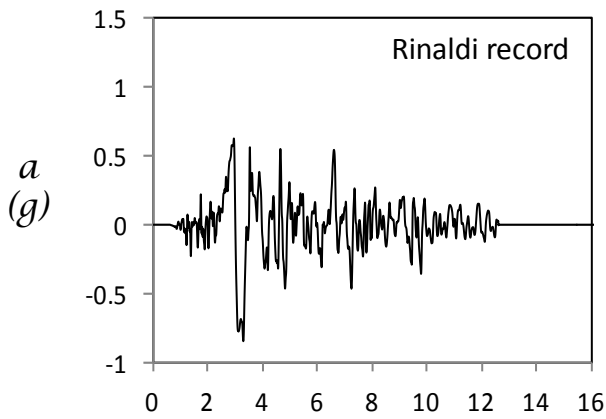

Figure B133. Acceleration time histories measured on the retrofitted building with rocking isolation ($b = 1.5\text{m}$, $t = 0.05\text{m}$) while submitted to the record of Rinaldi.

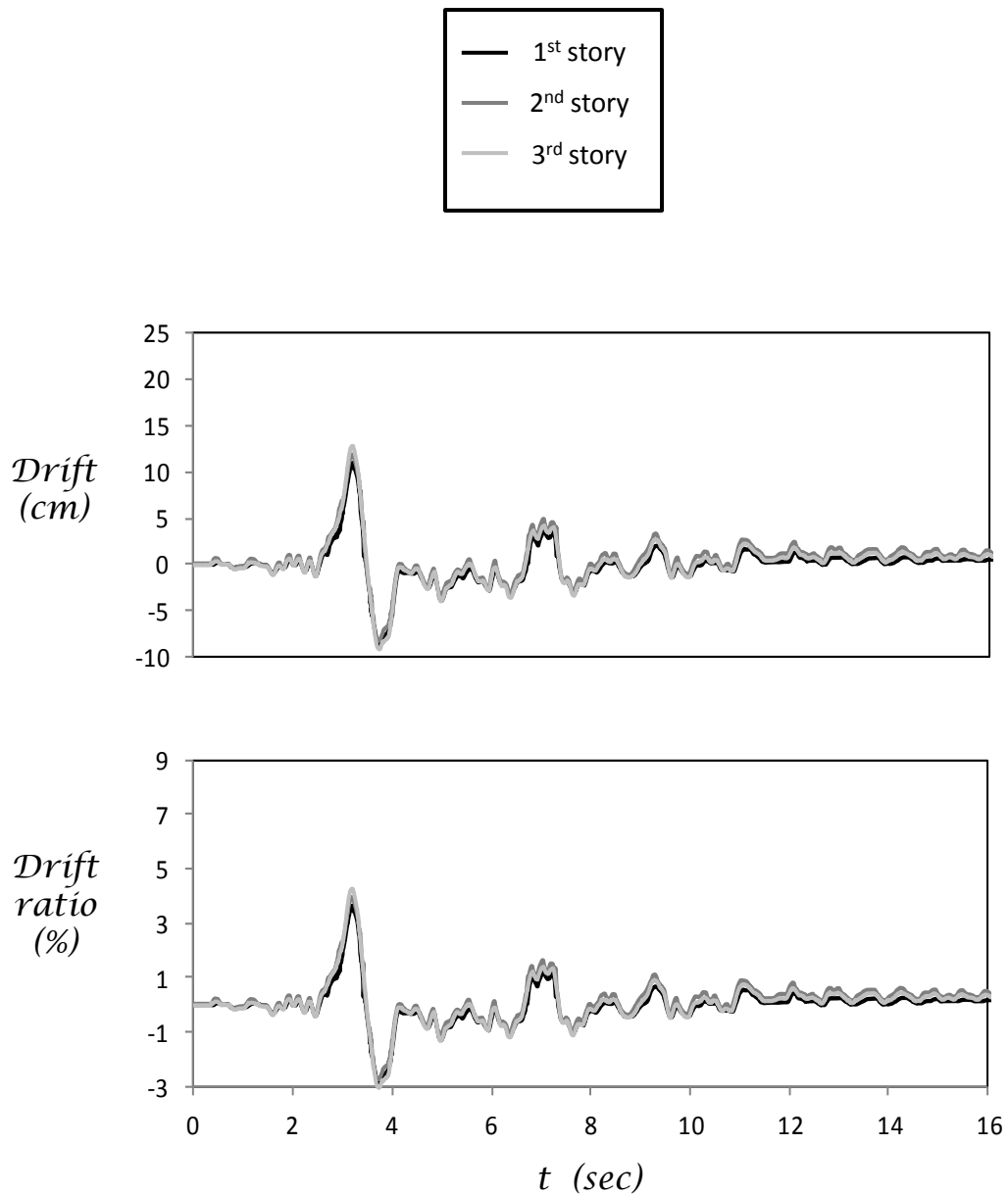
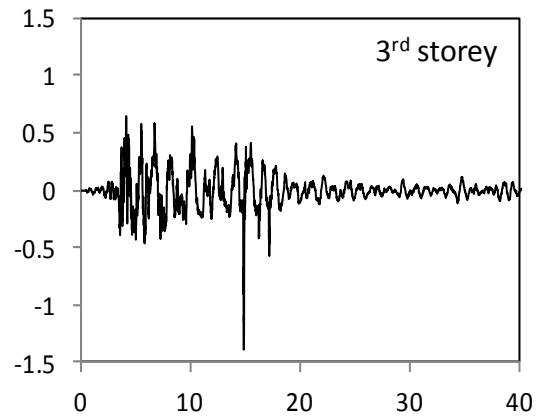
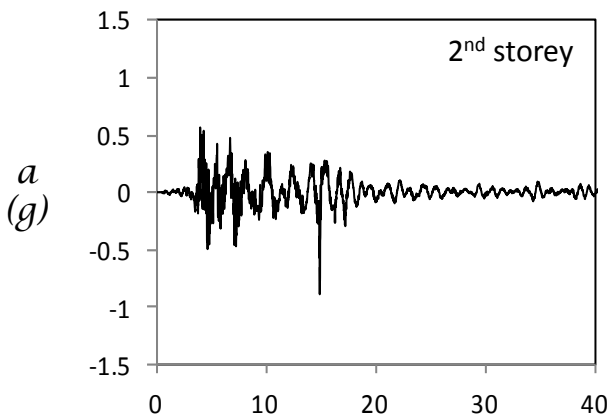
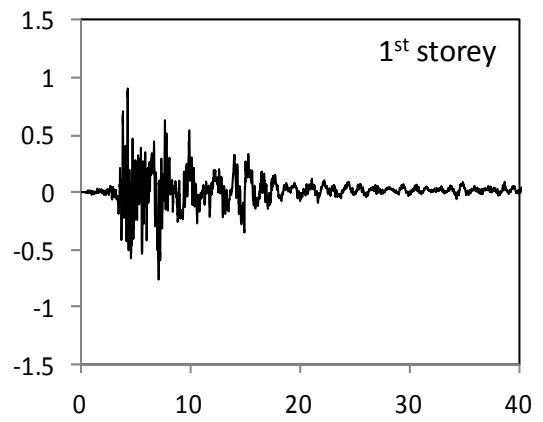
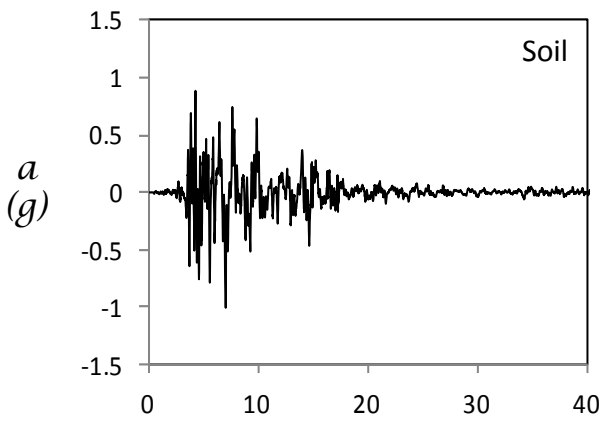
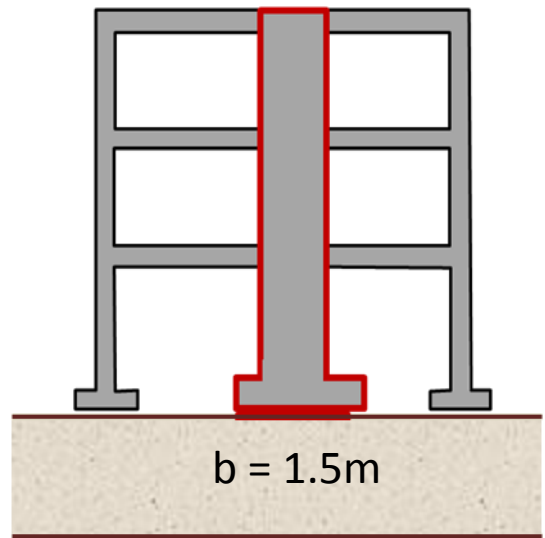
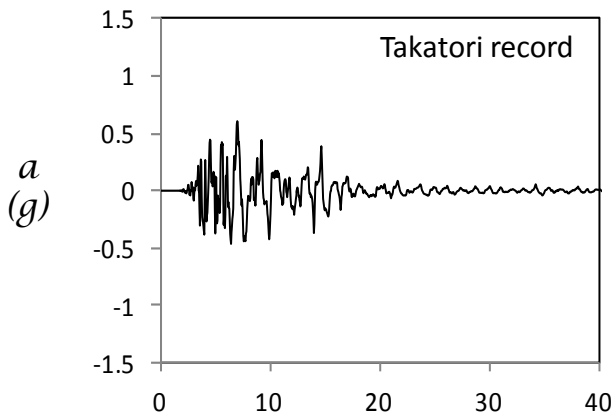

Figure B134. Time histories of storey drift and drift ratio of retrofitted building with rocking isolation ($b = 1.5\text{m}$, $t = 0.05\text{m}$) while submitted to the record of Rinaldi.



t (sec)

t (sec)

Figure B135. Acceleration time histories measured on the retrofitted building with rocking isolation ($b = 1.5\text{m}$, $t = 0.05\text{m}$) while submitted to the record of Takatori.

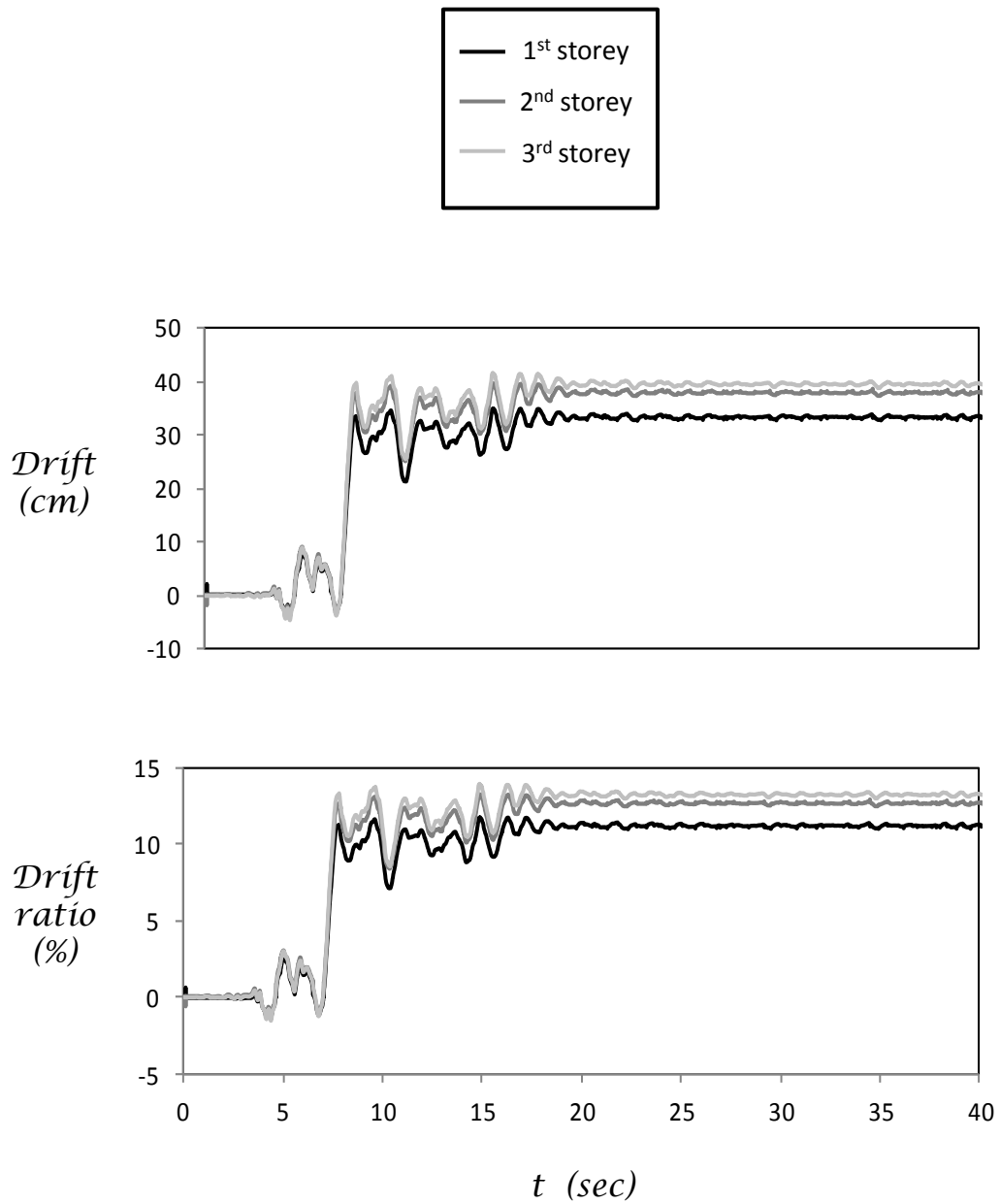
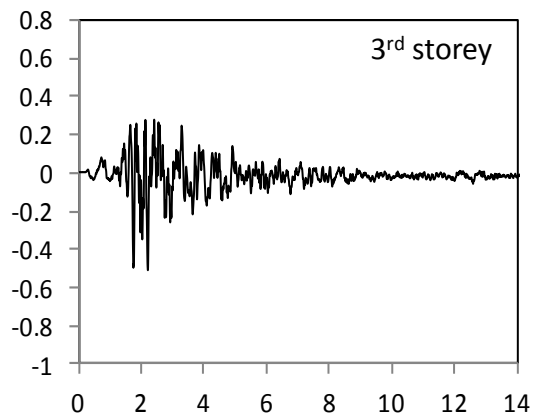
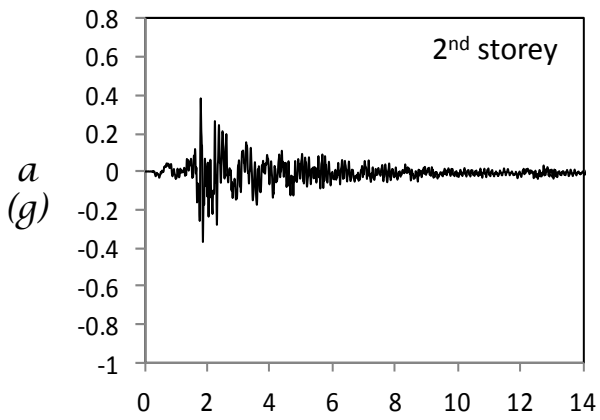
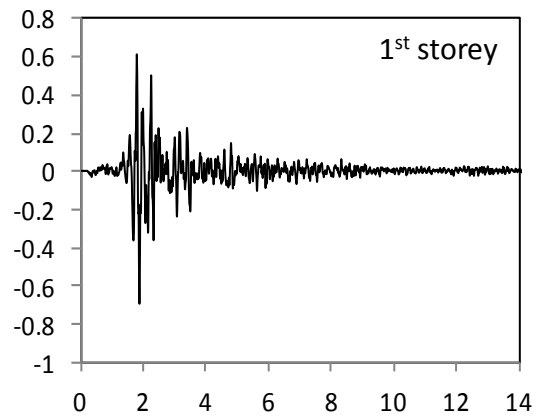
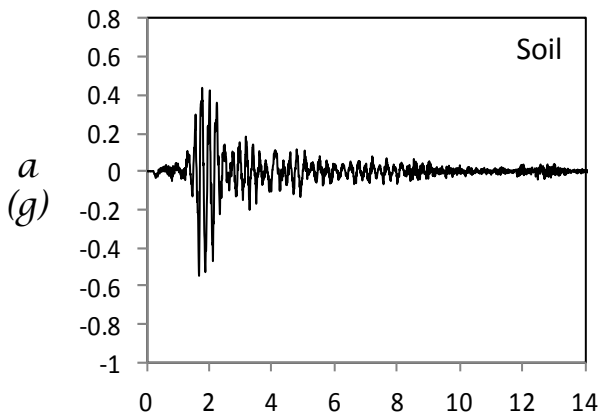
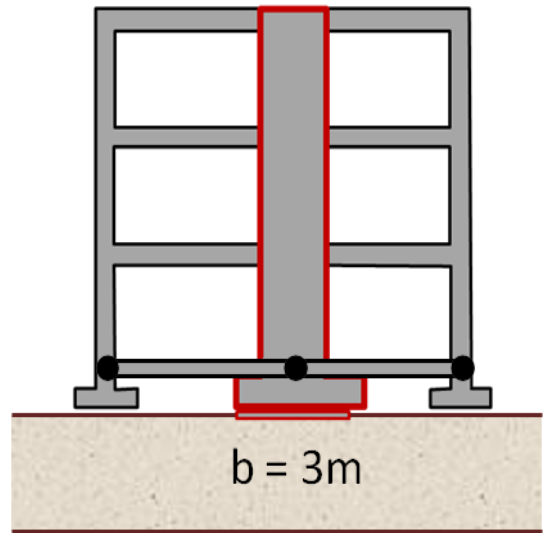
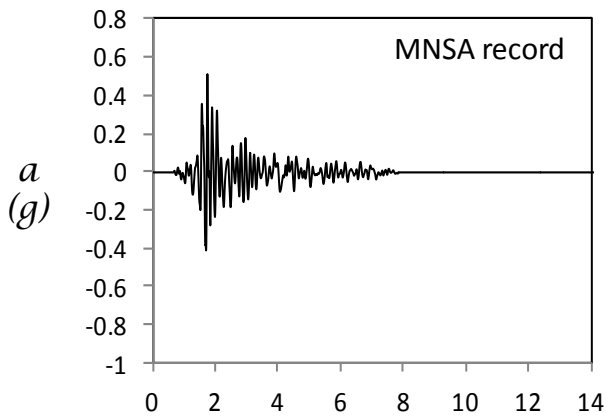

Figure B136. Time histories of storey drift and drift ratio of retrofitted building with rocking isolation ($b = 1.5\text{m}$, $t = 0.05\text{m}$) while submitted to the record of Takatori.

Retrofitted Building:

Hybrid Foundation with Tie Beams



t (sec)

t (sec)

Figure B137. Acceleration time histories measured on the retrofitted building with rocking isolation ($b = 3\text{m}$, $t = 0.05\text{m}$) and hinged tie beams while submitted to the record of MNSA.

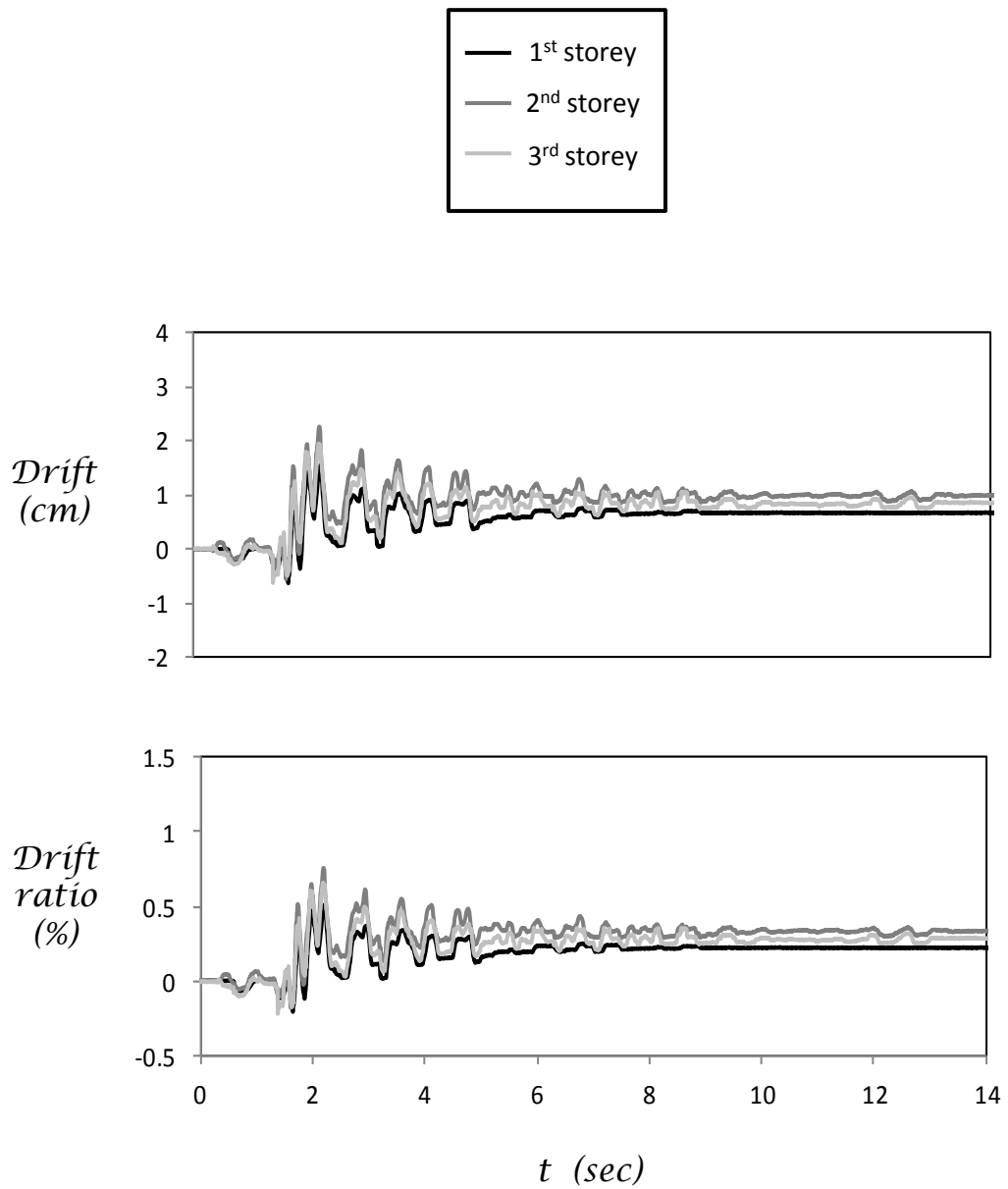

Figure B138. Time histories of storey drift and drift ratio of retrofitted building with rocking isolation ($b = 3\text{m}$, $t = 0.05\text{m}$) and hinged tie beams while submitted to the record of MNSA.

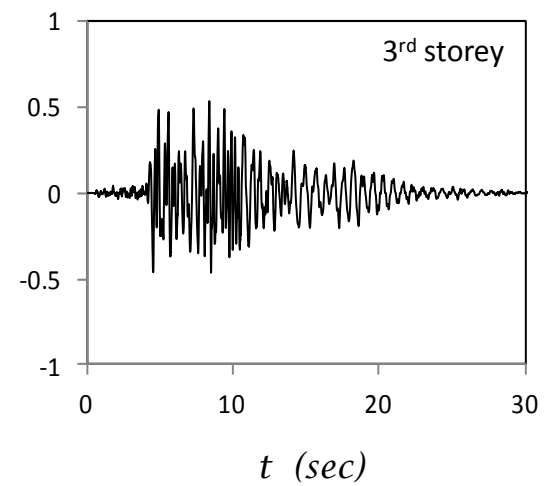
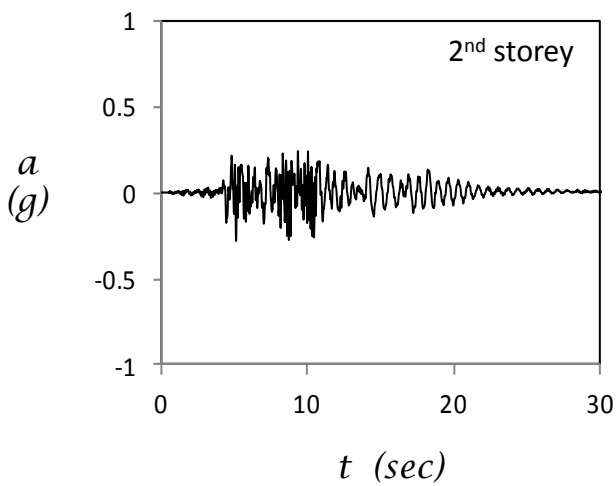
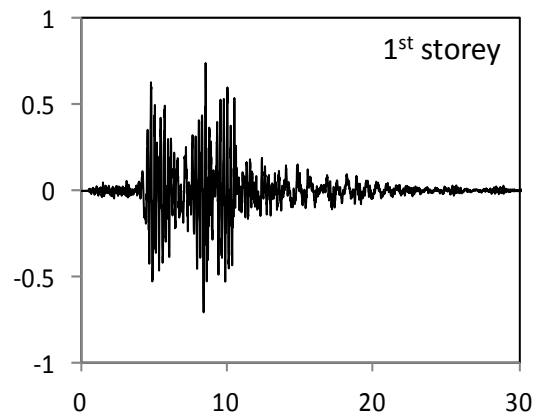
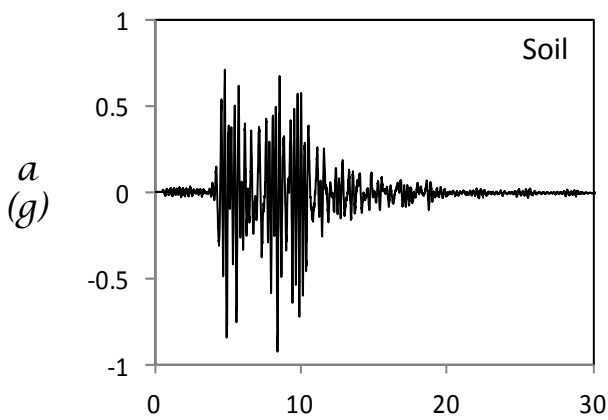
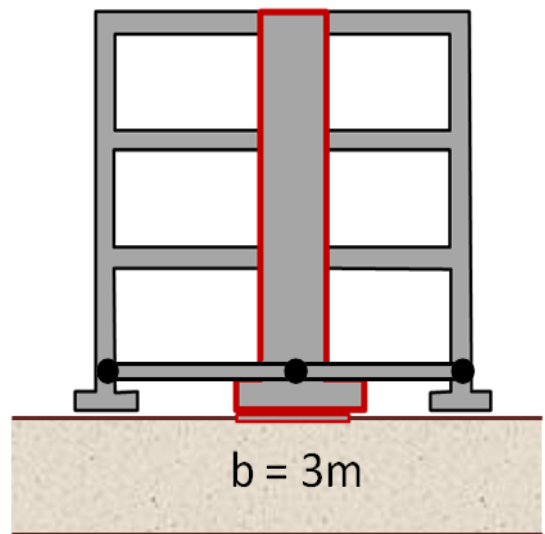
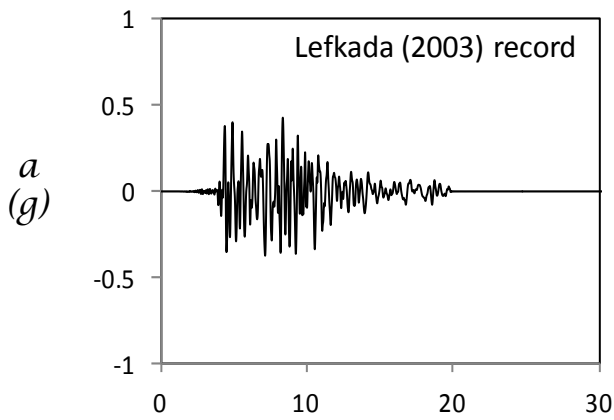

Figure B139. Acceleration time histories measured on the retrofitted building with rocking isolation ($b = 3\text{m}$, $t = 0.05\text{m}$) and hinged tie beams while submitted to the record of Lefkada (2003).

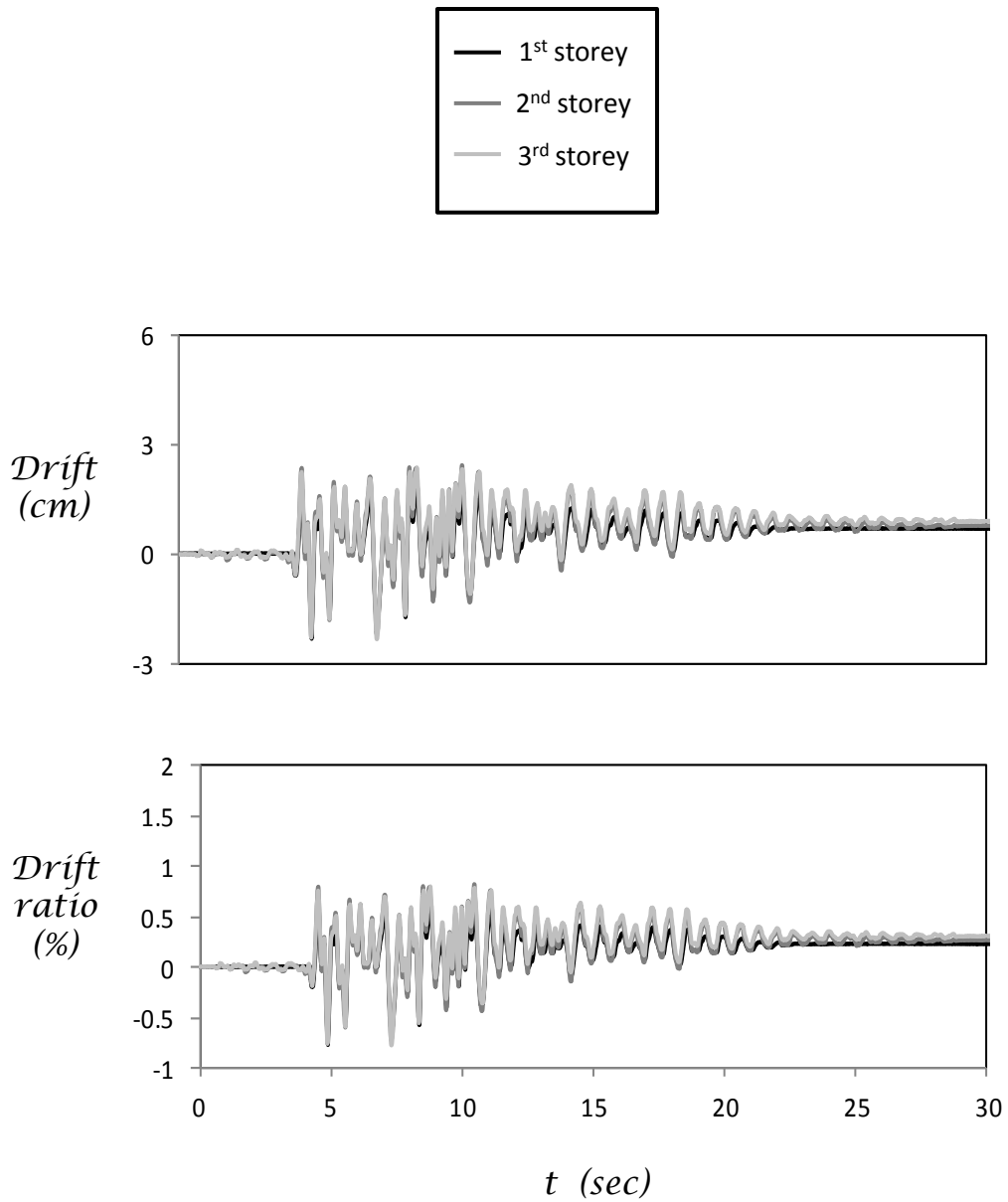
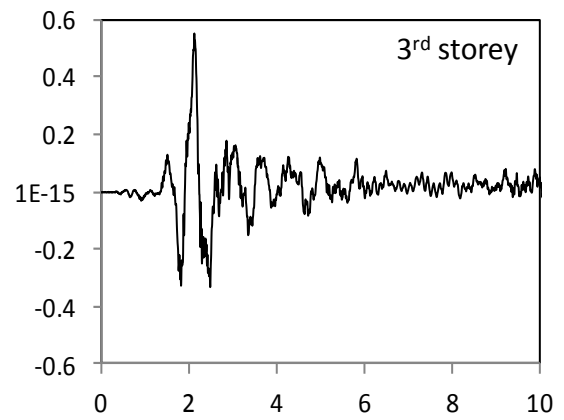
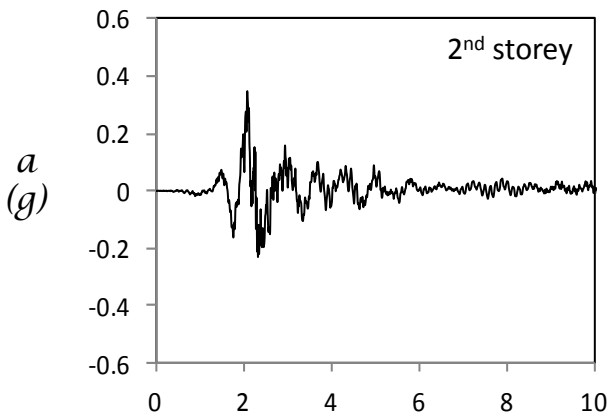
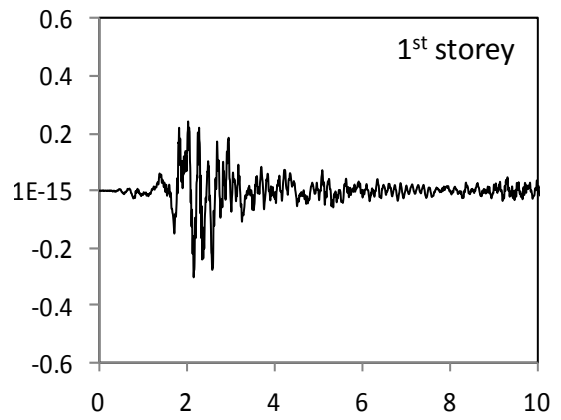
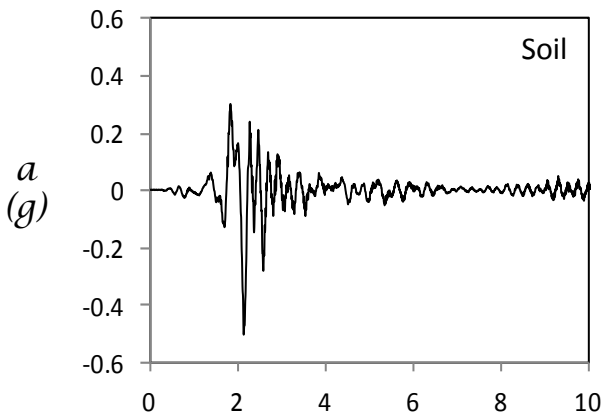
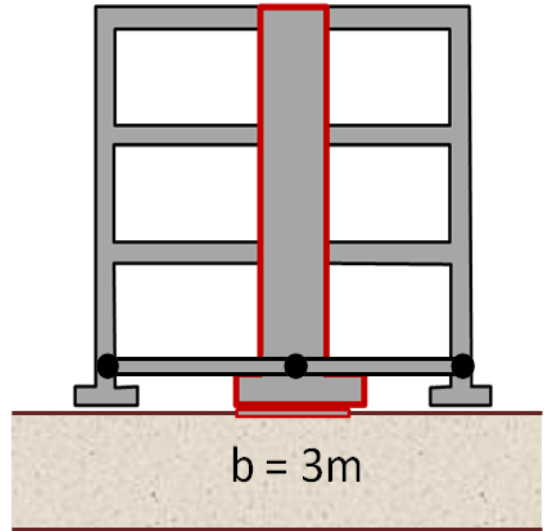
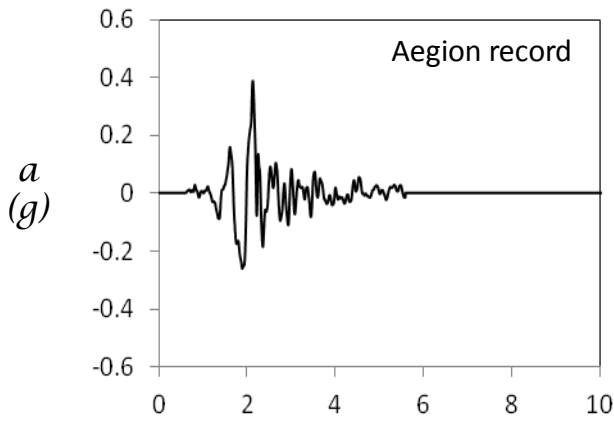

Figure B140. Time histories of storey drift and drift ratio of retrofitted building with rocking isolation ($b = 3\text{m}$, $t = 0.05\text{m}$) and hinged tie beams while submitted to the record of Lefkada (2003).



t (sec)

t (sec)

Figure B141. Acceleration time histories measured on the retrofitted building with rocking isolation ($b = 3\text{m}$, $t = 0.05\text{m}$) and hinged tie beams while submitted to the record of Aegion.

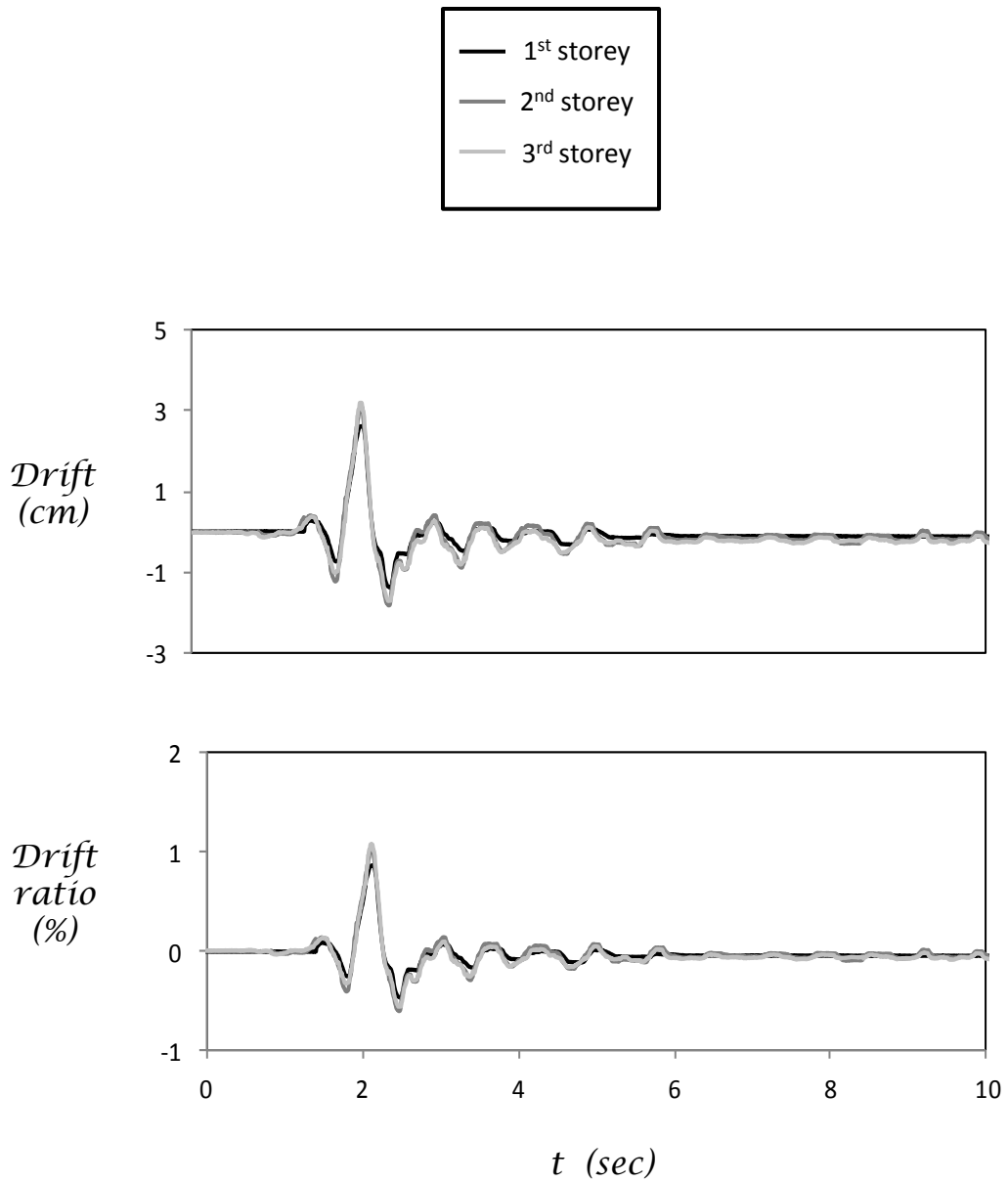
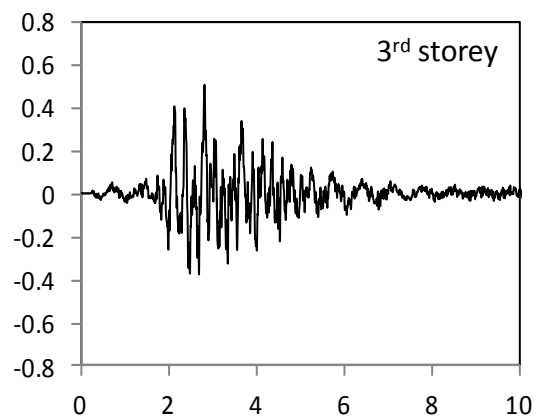
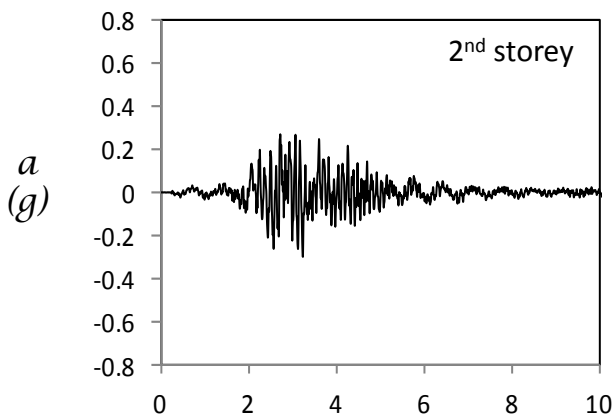
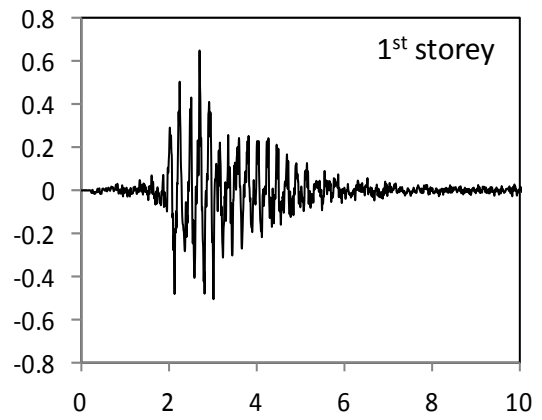
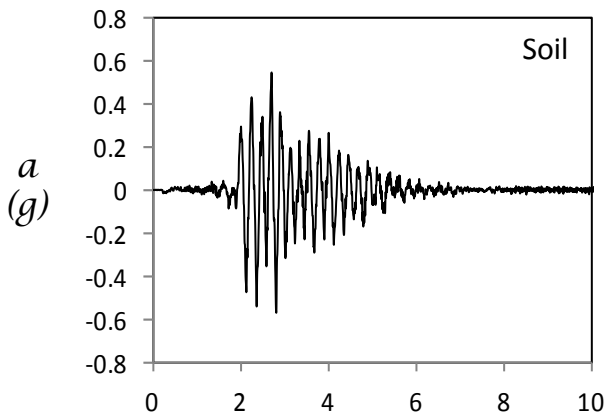
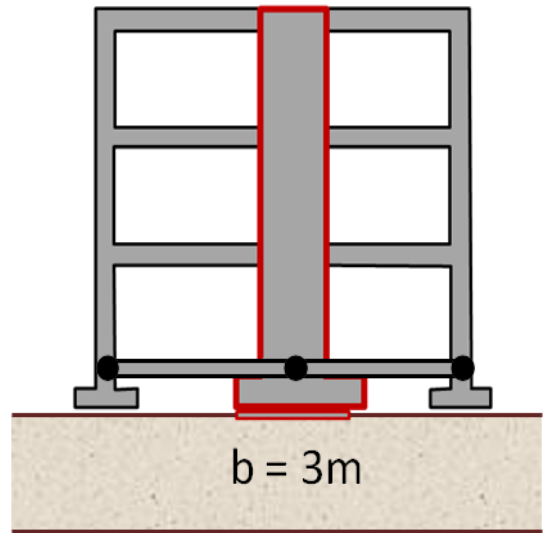
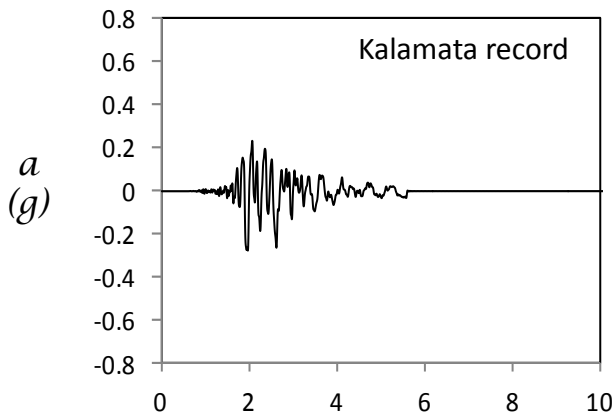

Figure B142. Time histories of storey drift and drift ratio of retrofitted building with rocking isolation ($b = 3\text{m}$, $t = 0.05\text{m}$) and hinged tie beams while submitted to the record of Aegion.



t (sec)

t (sec)

Figure B143. Acceleration time histories measured on the retrofitted building with rocking isolation ($b = 3\text{m}$, $t = 0.05\text{m}$) and hinged tie beams while submitted to the record of Kalamata.

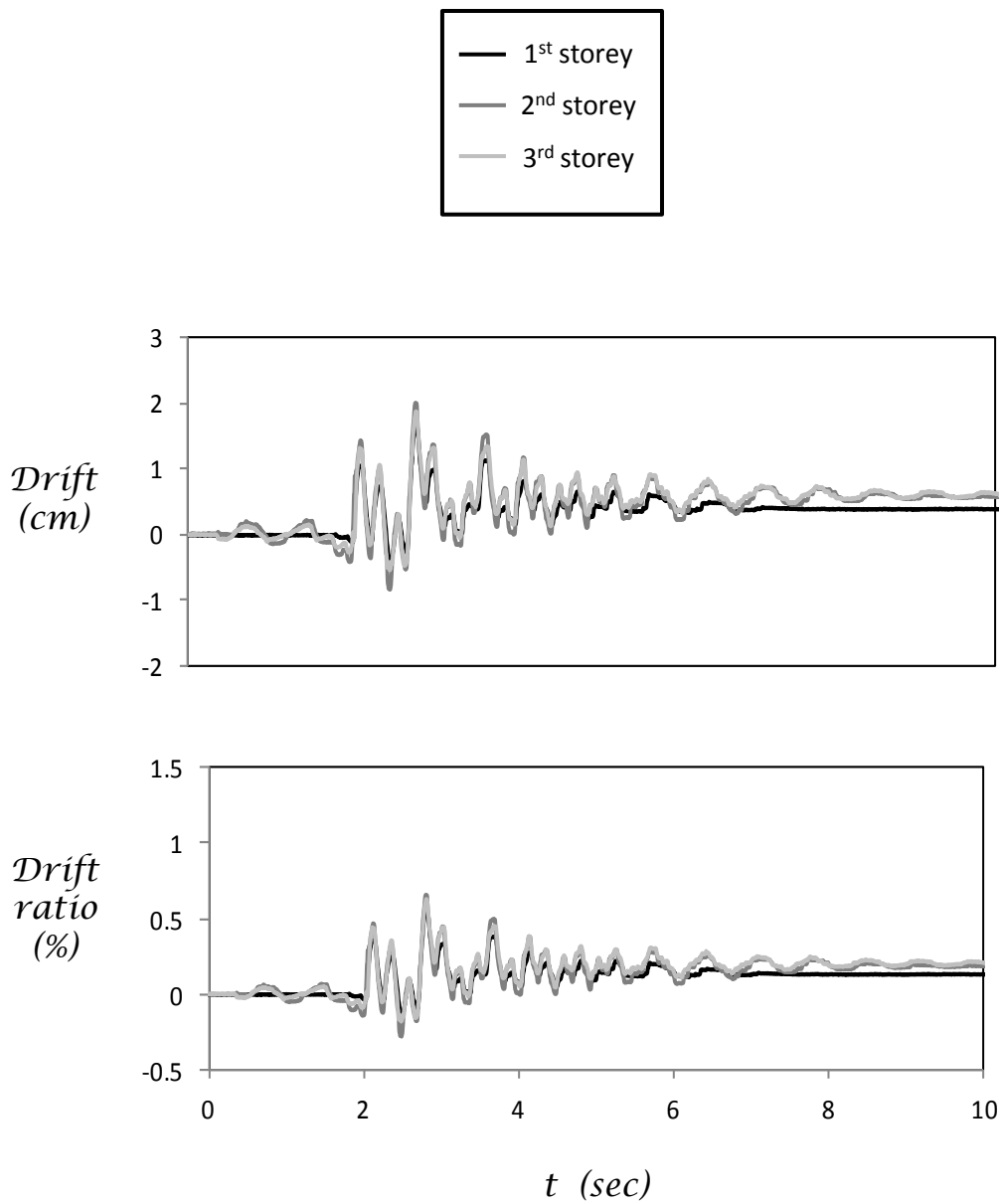

Figure B144. Time histories of storey drift and drift ratio of retrofitted building with rocking isolation ($b = 3\text{m}$, $t = 0.05\text{m}$) and hinged tie beams while submitted to the record of Kalamata.

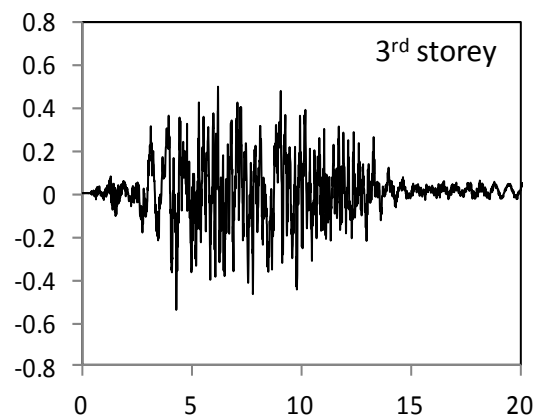
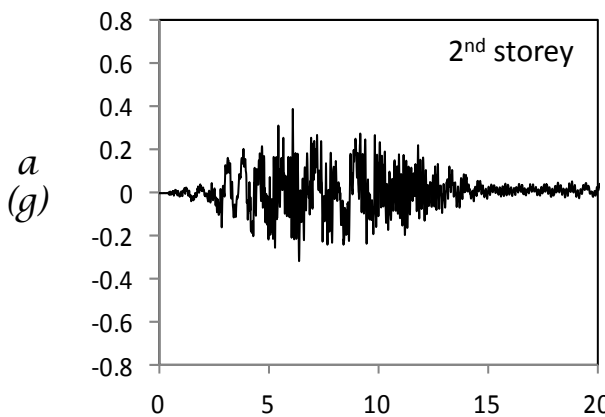
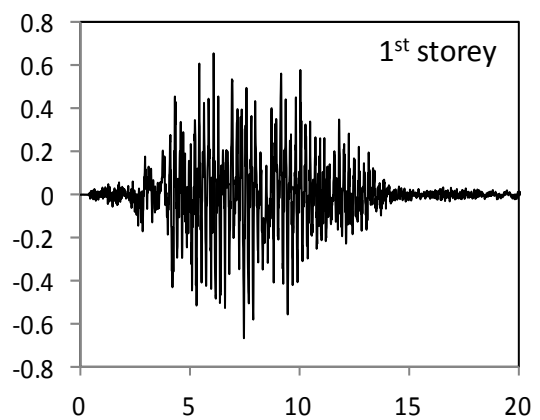
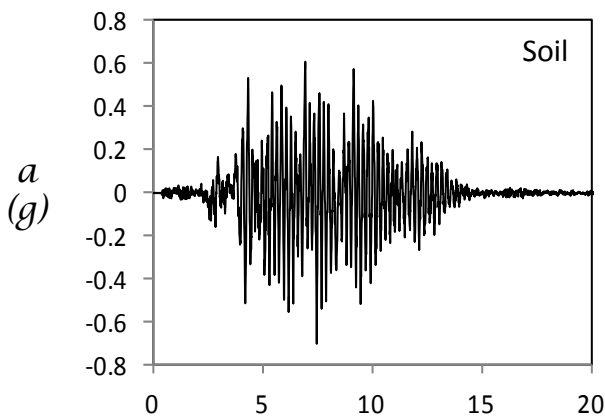
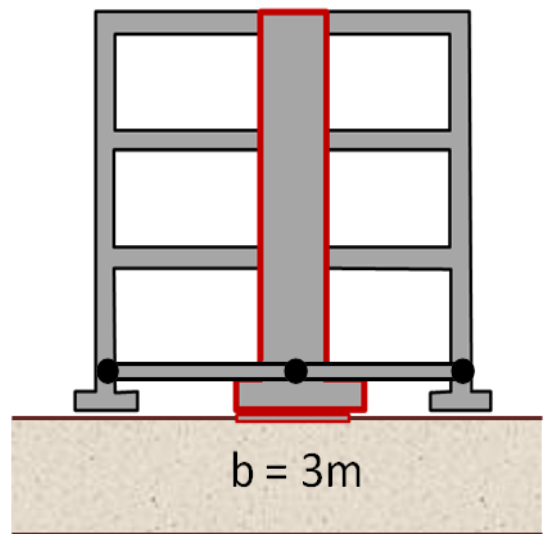
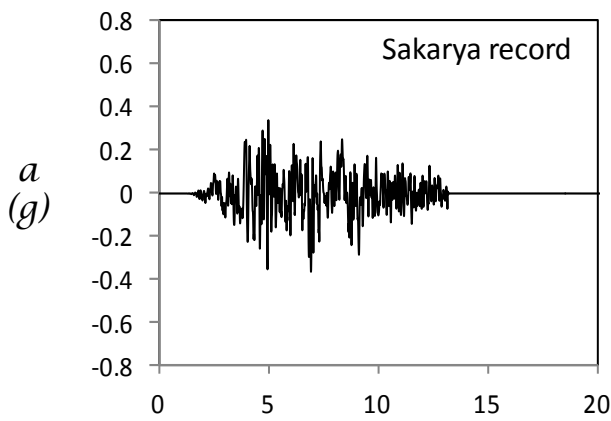

Figure B145. Acceleration time histories measured on the retrofitted building with rocking isolation ($b = 3\text{m}$, $t = 0.05\text{m}$) and hinged tie beams while submitted to the record of Sakarya.

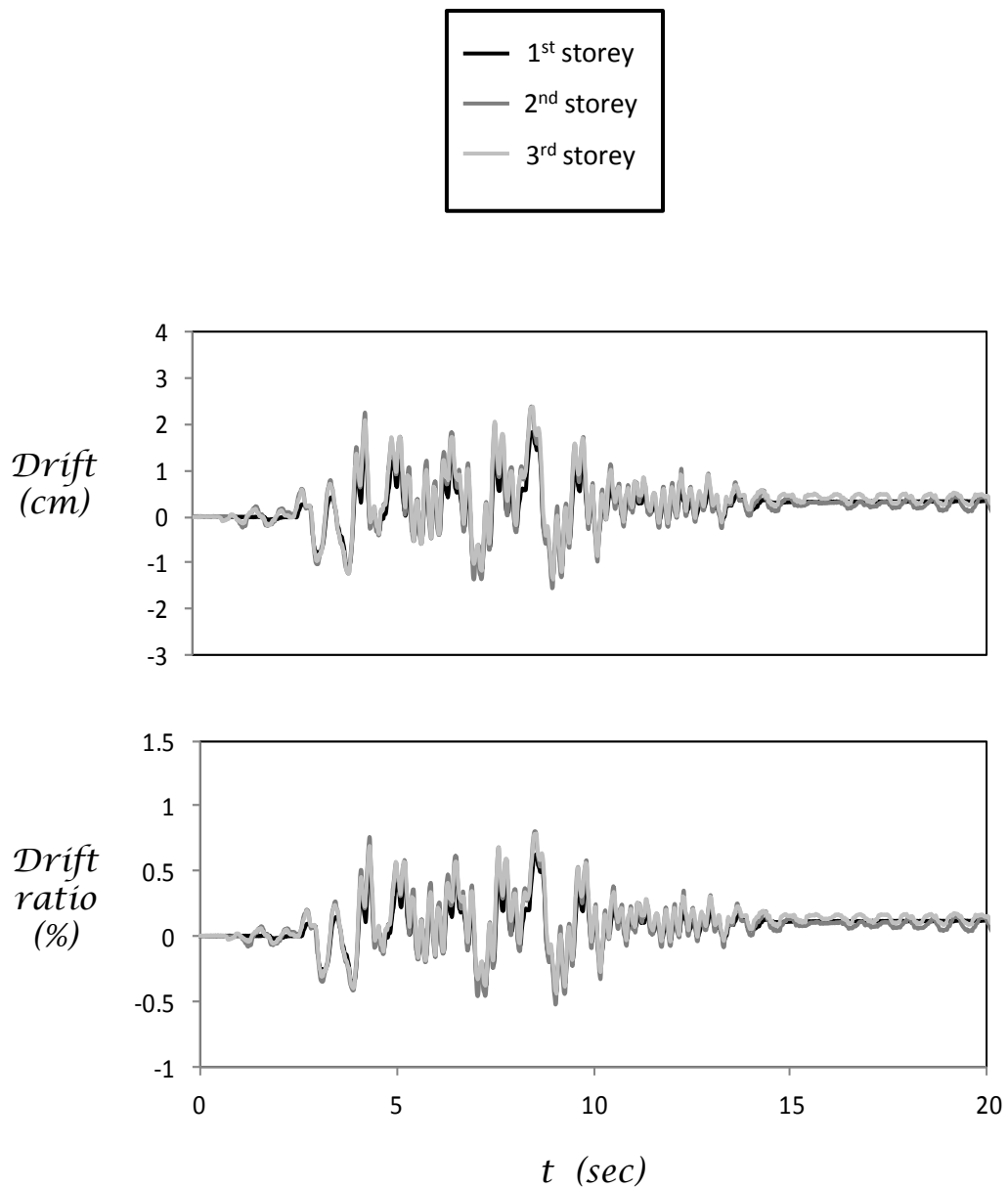
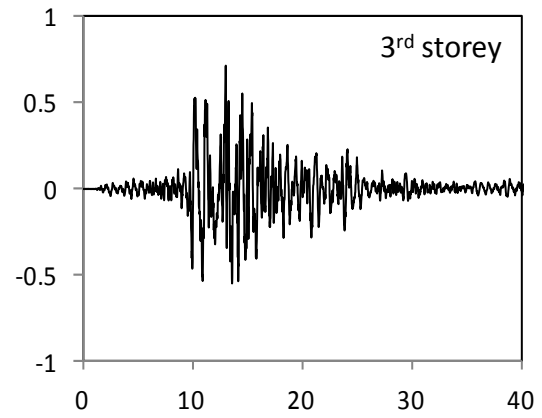
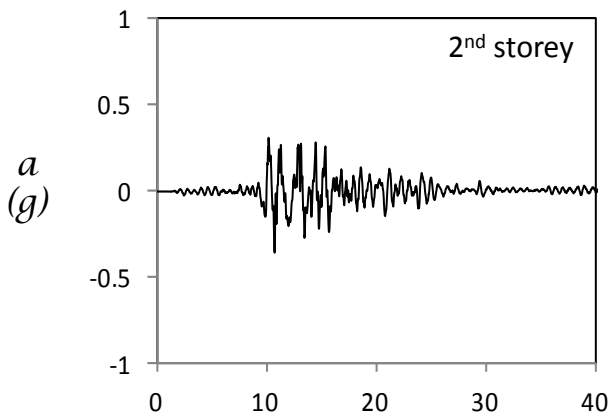
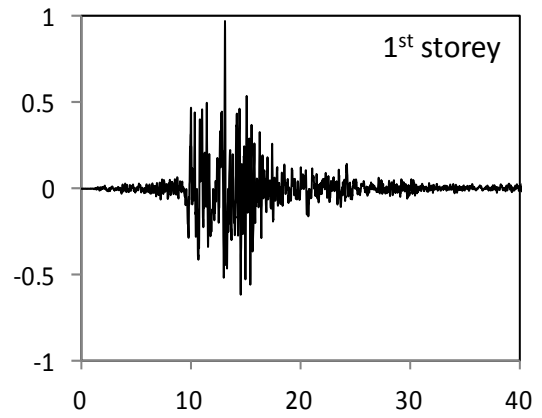
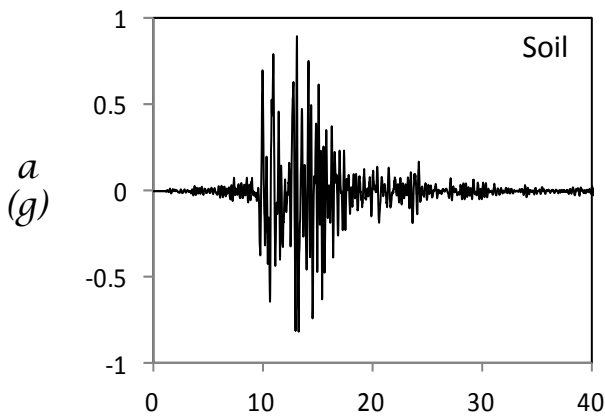
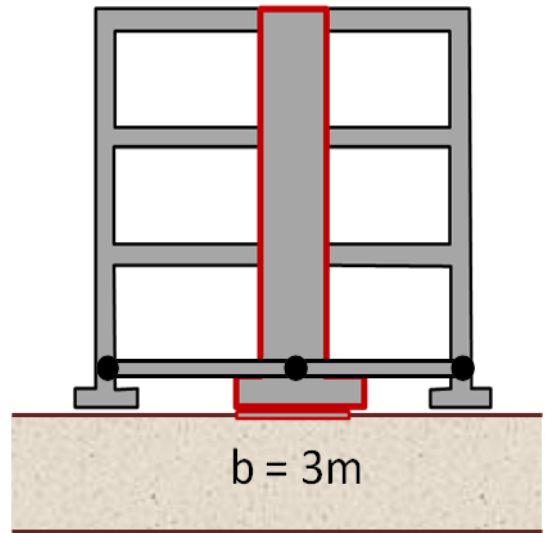
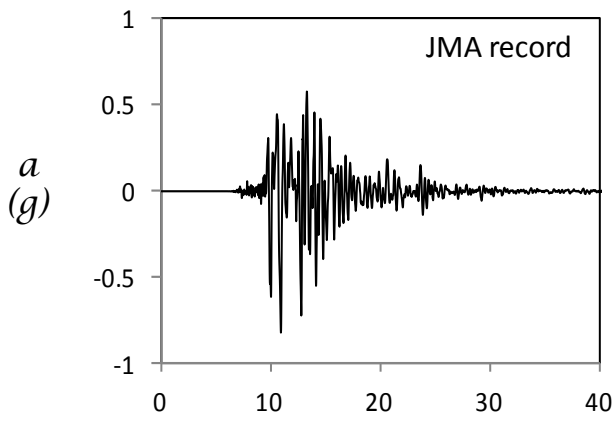

Figure B146. Time histories of storey drift and drift ratio of retrofitted building with rocking isolation ($b = 3\text{m}$, $t = 0.05\text{m}$) and hinged tie beams while submitted to the record of Sakarya.



t (sec)

t (sec)

Figure B147. Acceleration time histories measured on the retrofitted building with rocking isolation ($b = 3\text{m}$, $t = 0.05\text{m}$) and hinged tie beams while submitted to the record of JMA.

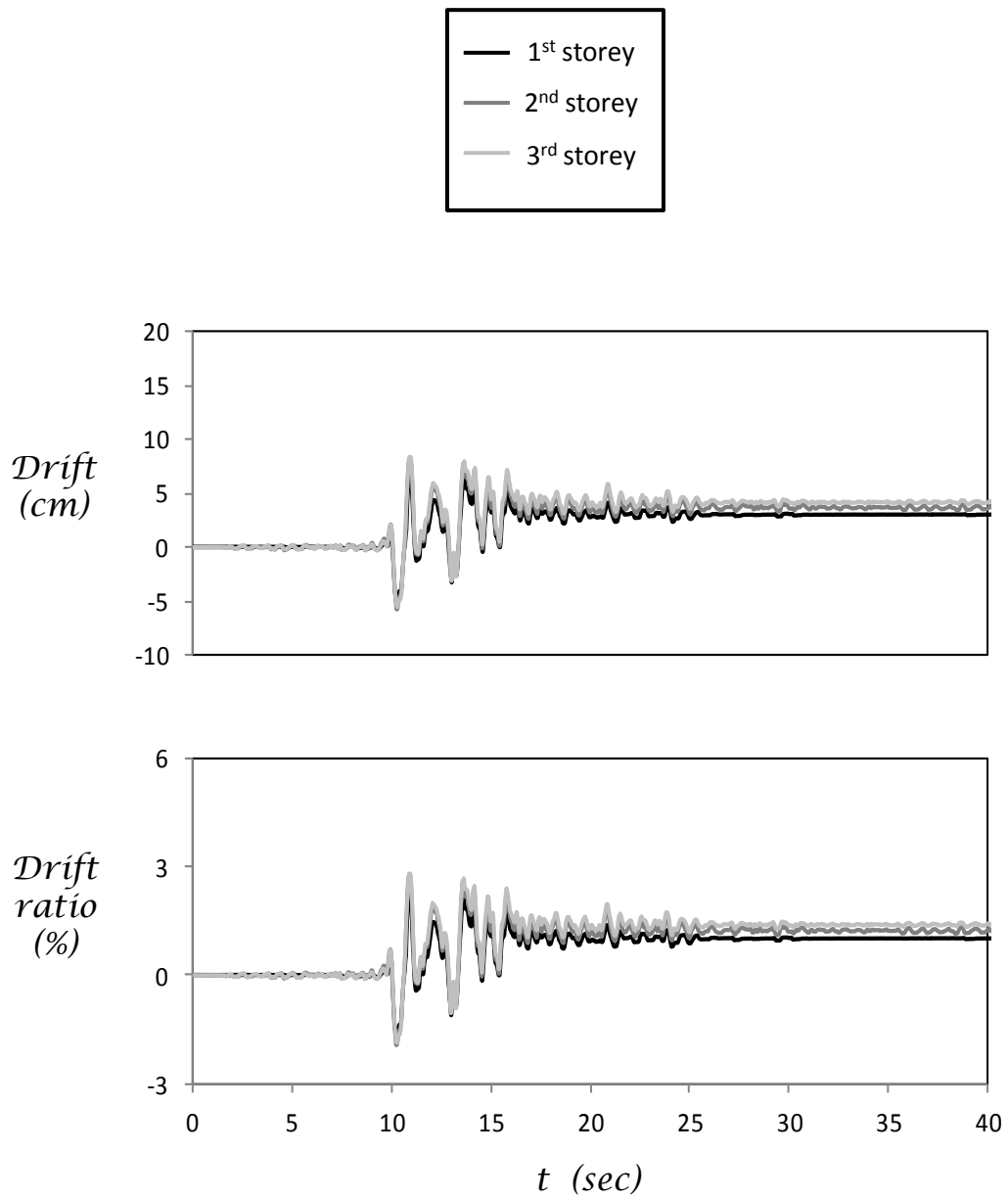

Figure B148. Time histories of storey drift and drift ratio of retrofitted building with rocking isolation ($b = 3\text{ m}$, $t = 0.05\text{ m}$) and hinged tie beams while submitted to the record of JMA.

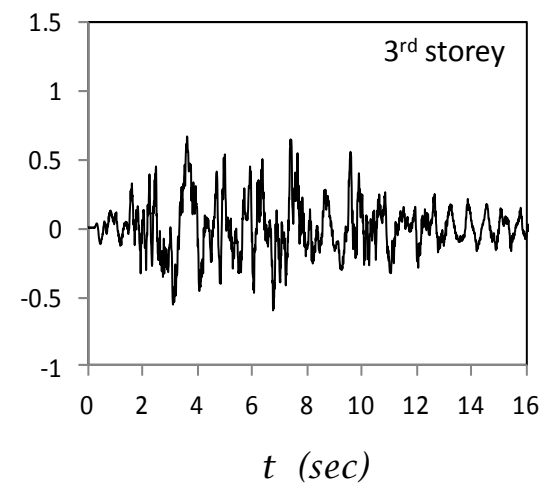
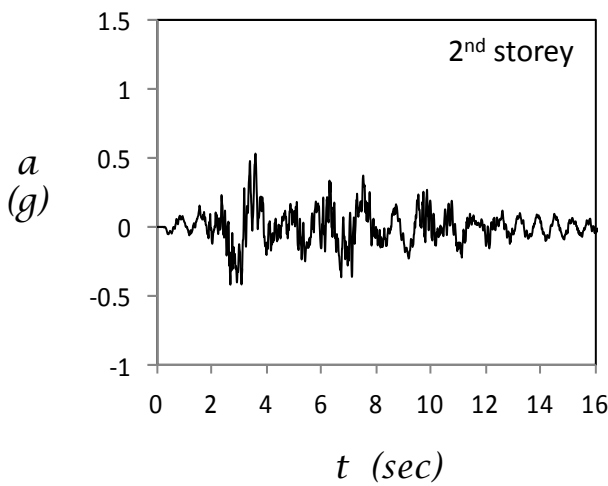
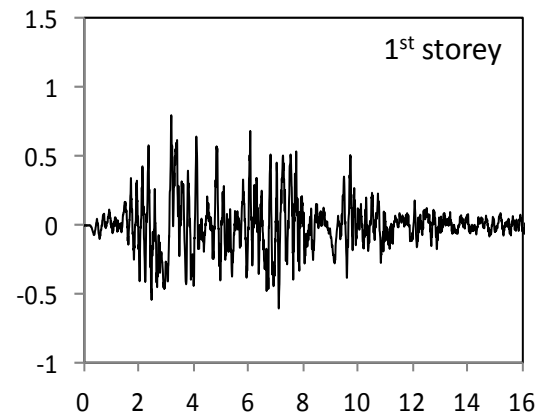
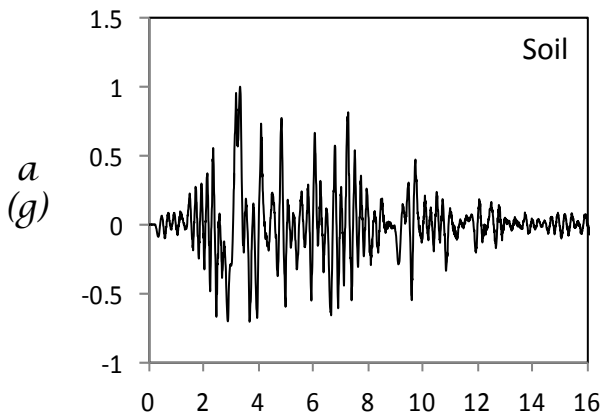
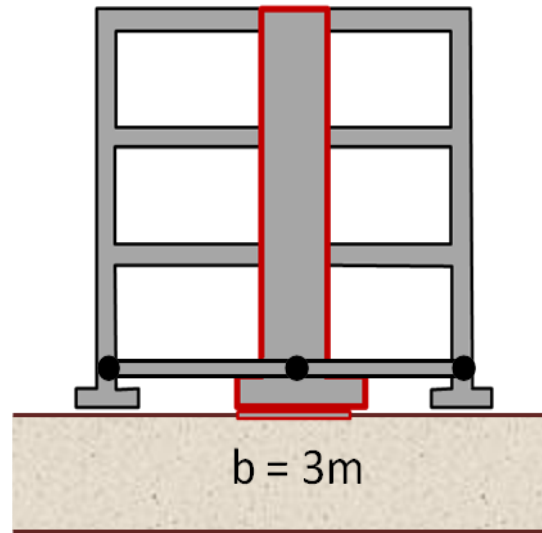
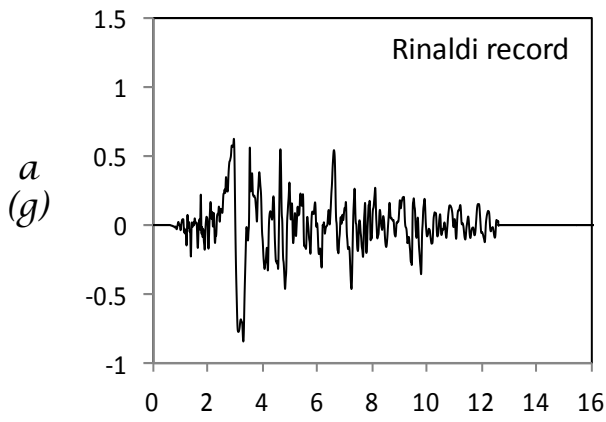

Figure B149. Acceleration time histories measured on the retrofitted building with rocking isolation ($b = 3\text{m}$, $t = 0.05\text{m}$) and hinged tie beams while submitted to the record of Rinaldi.

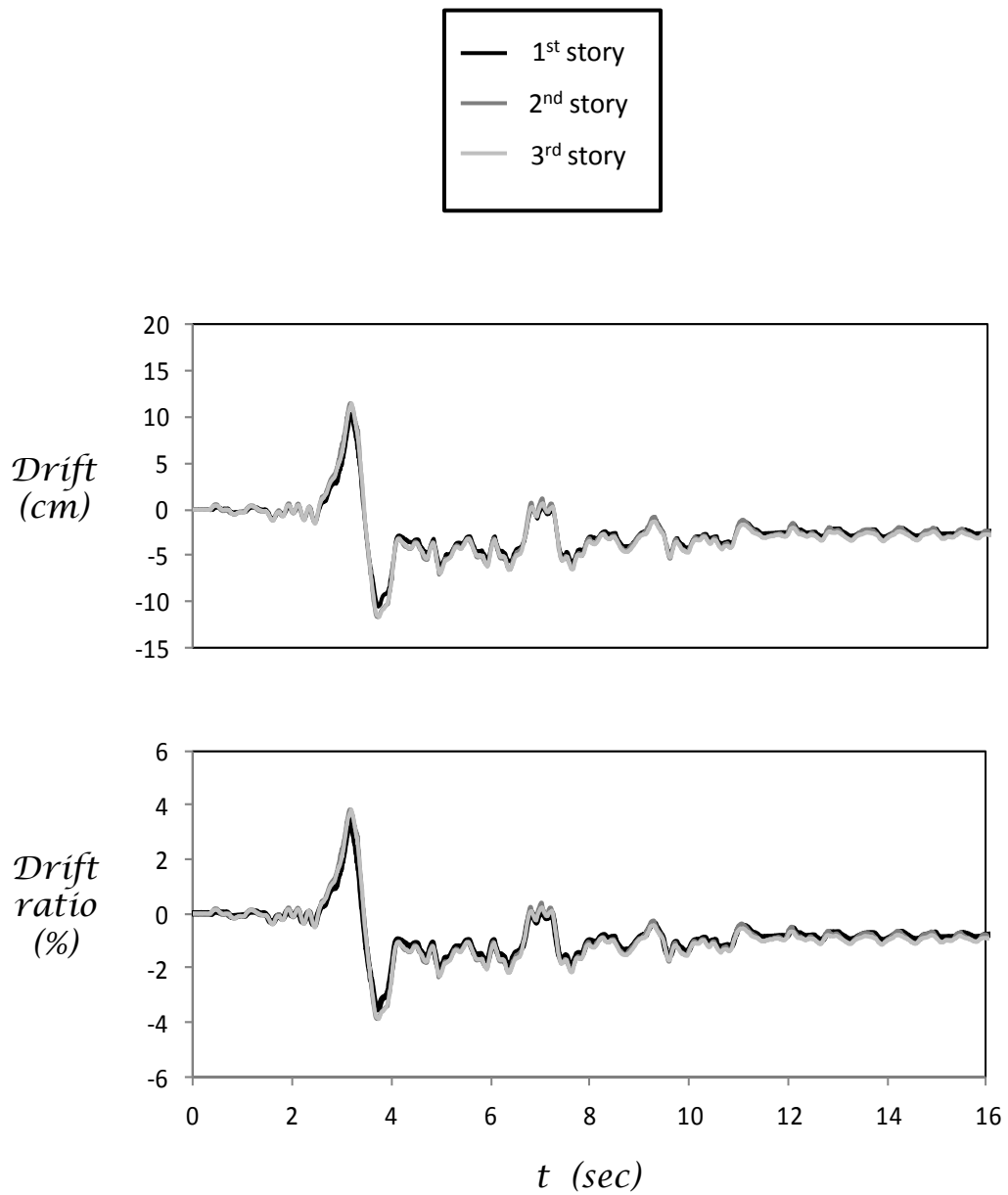

Figure B150. Time histories of storey drift and drift ratio of retrofitted with rocking isolation ($b = 3\text{m}$, $t = 0.05\text{m}$) and hinged tie beams while submitted to the record of Rinaldi.

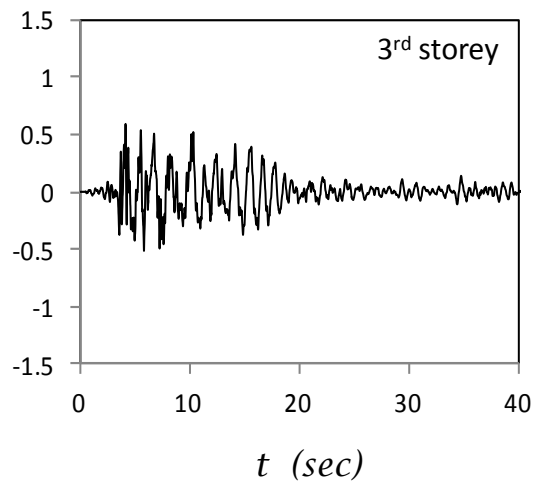
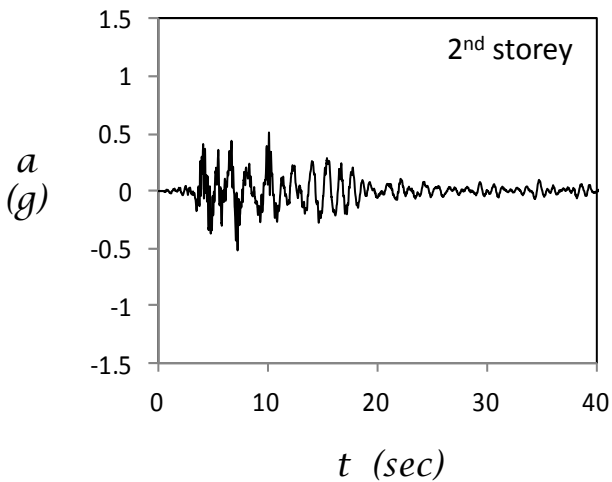
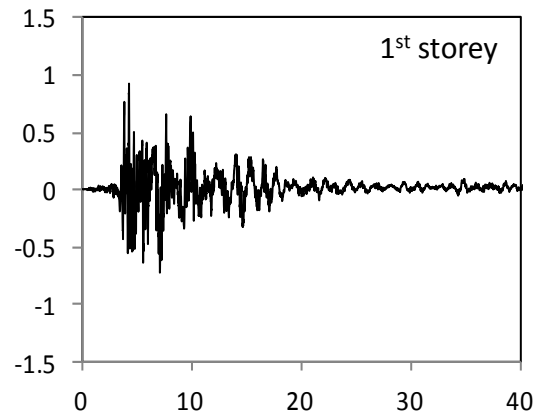
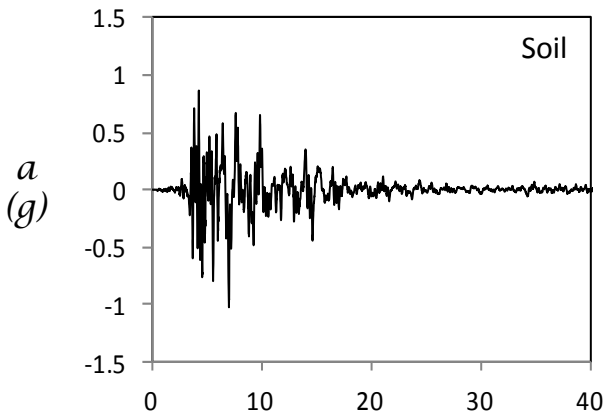
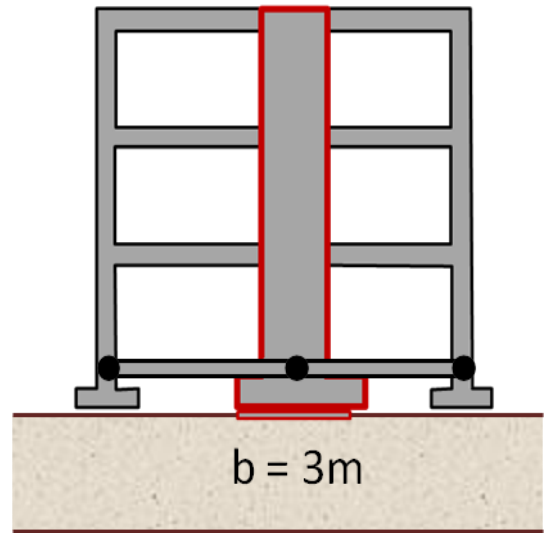
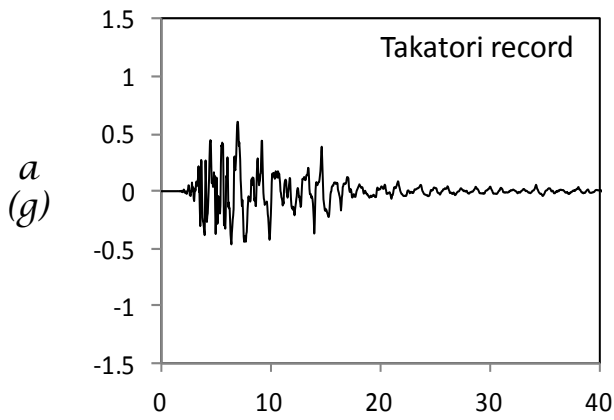

Figure B151. Acceleration time histories measured on the retrofitted building with rocking isolation ($b = 3\text{m}$, $t = 0.05\text{m}$) and hinged tie beams while submitted to the record of Takatori.

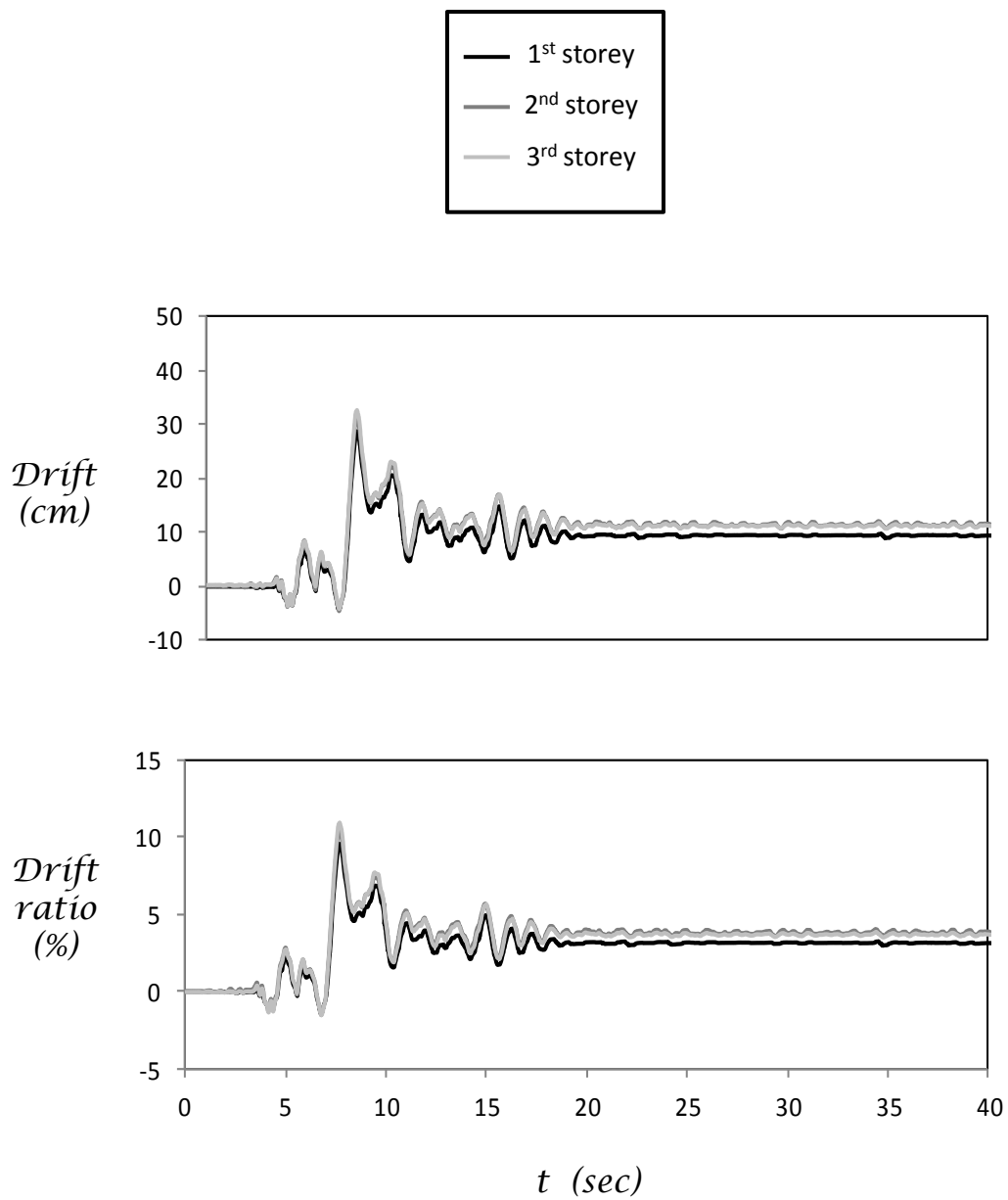

Figure B152. Time histories of storey drift and drift ratio of retrofitted building with rocking isolation ($b = 3\text{m}$, $t = 0.05\text{m}$) and hinged tie beams while submitted to the record of Takatori.

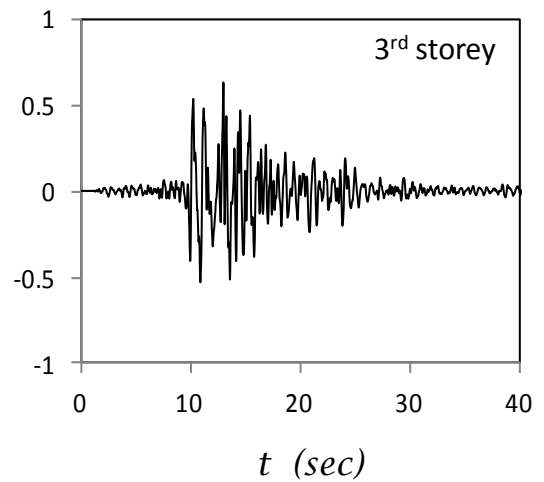
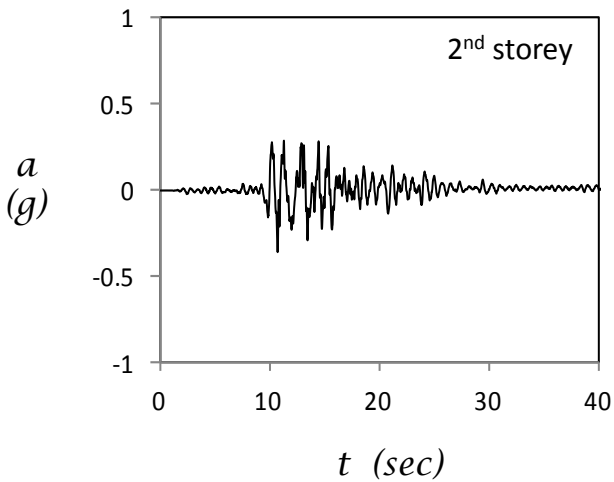
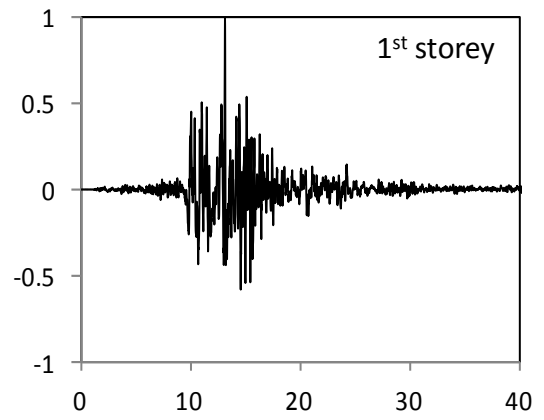
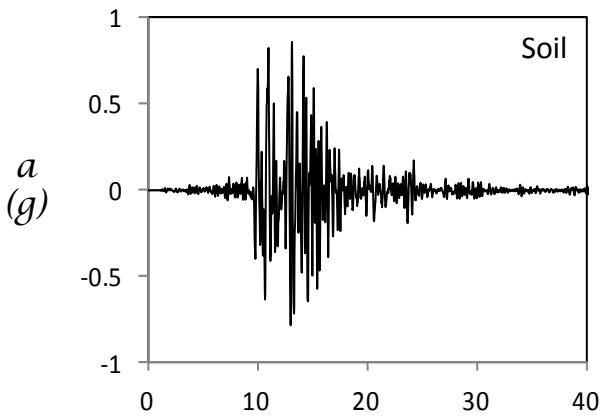
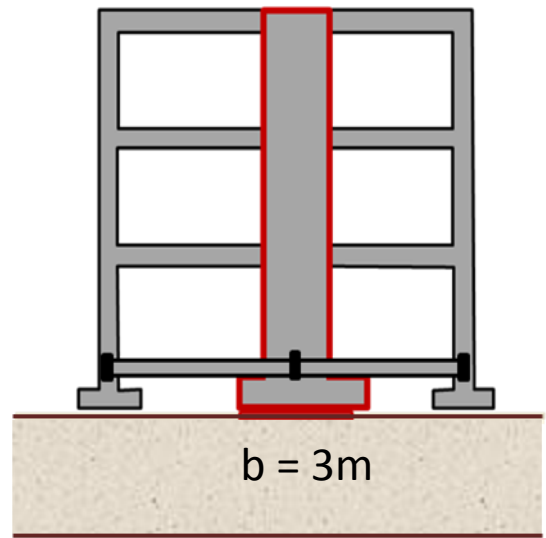
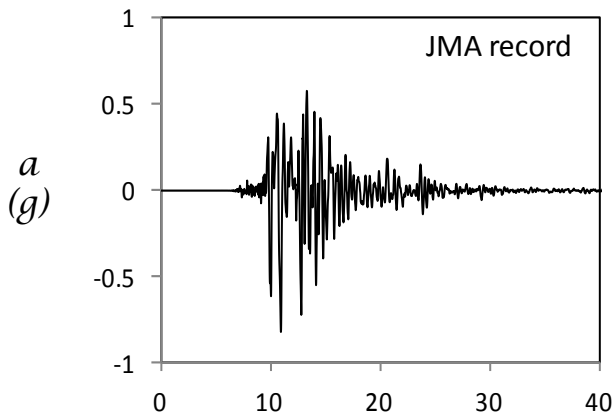

Figure B153. Acceleration time histories measured on the retrofitted building ($b = 3\text{m}$, $t = 0.05\text{m}$) with fixed tie beams while submitted to the record of JMA.

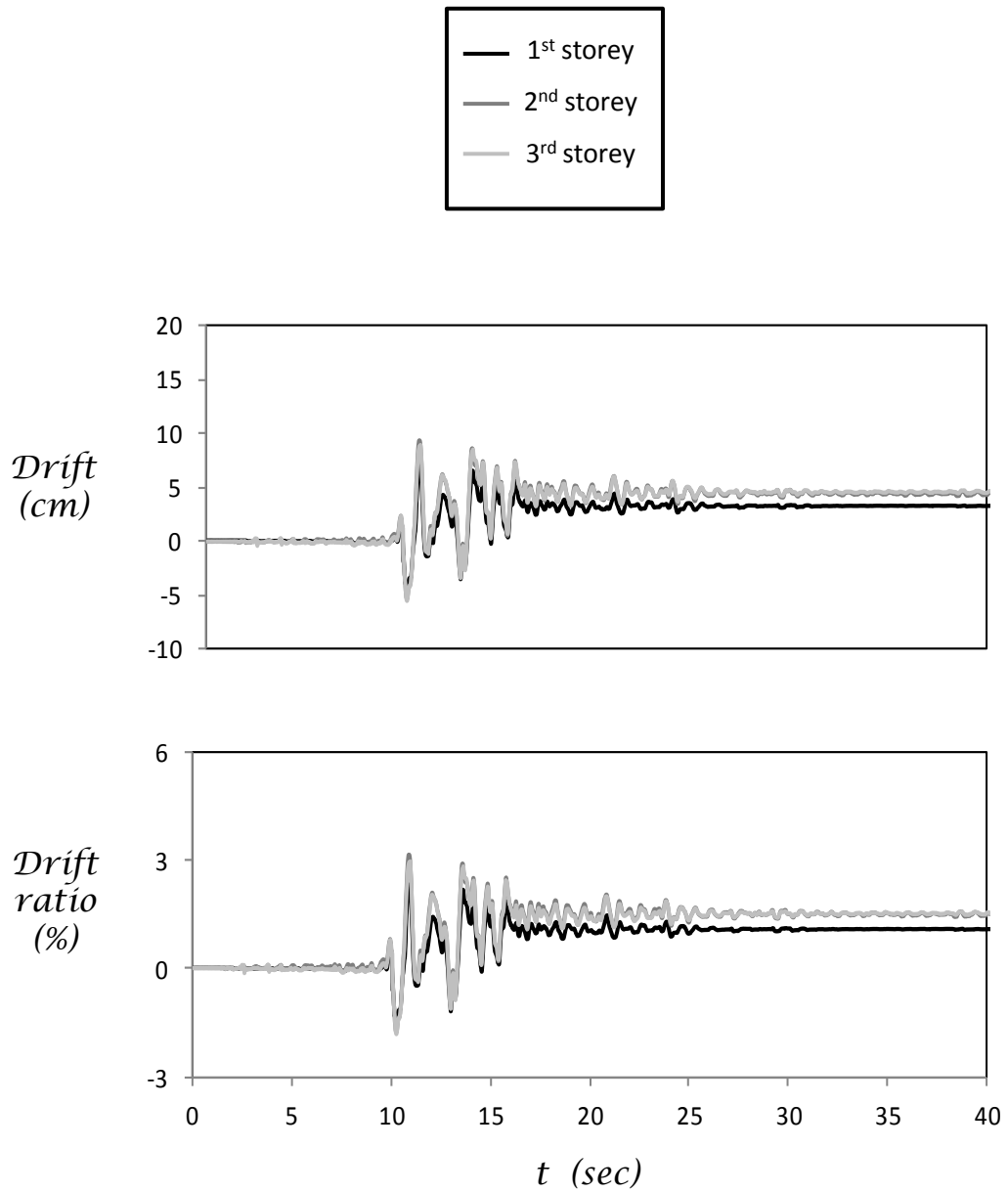

Figure B154. Time histories of storey drift and drift ratio of retrofitted building ($b = 3\text{ m}$, $t = 0.05\text{ m}$) with fixed tie beams while submitted to the record of JMA.

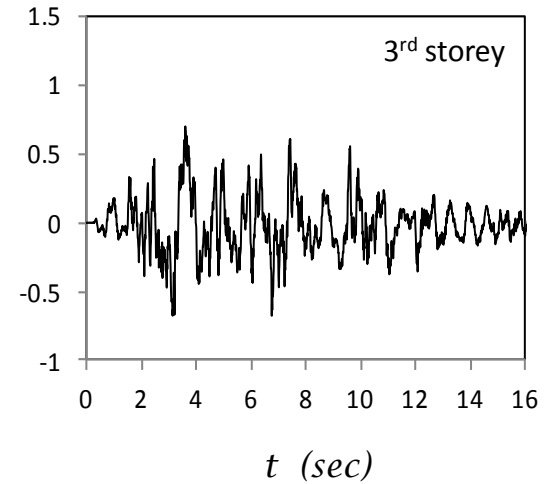
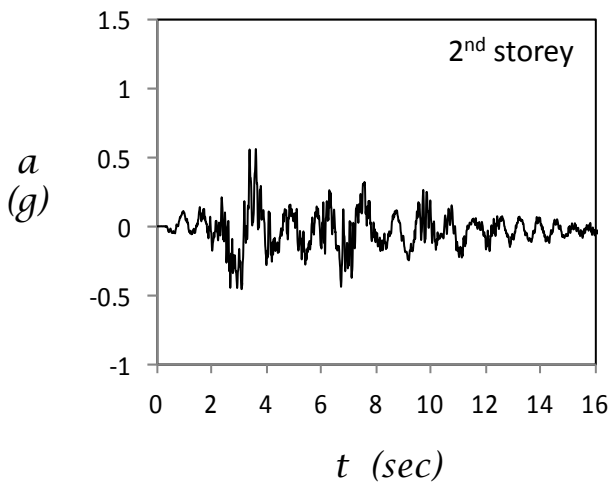
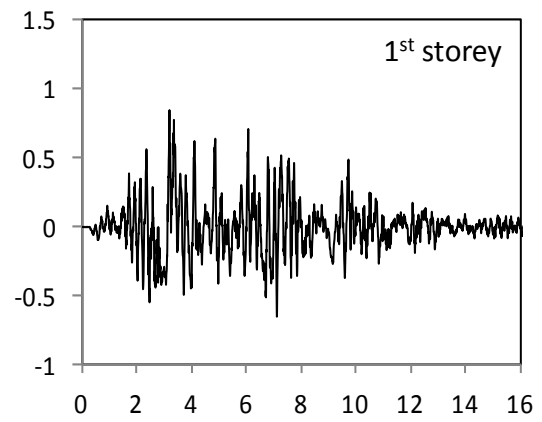
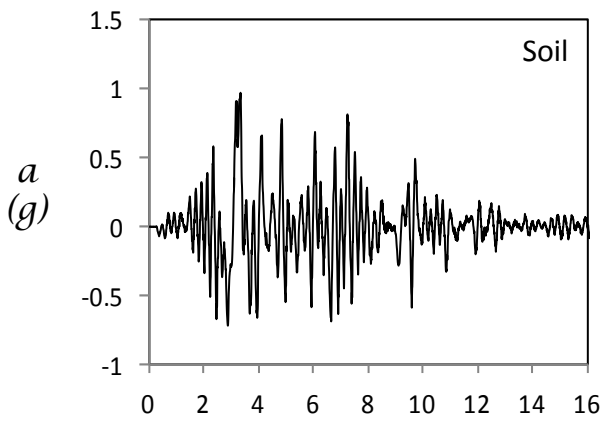
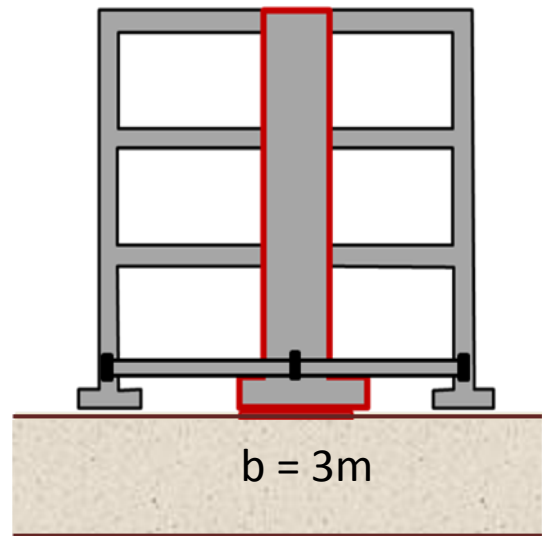
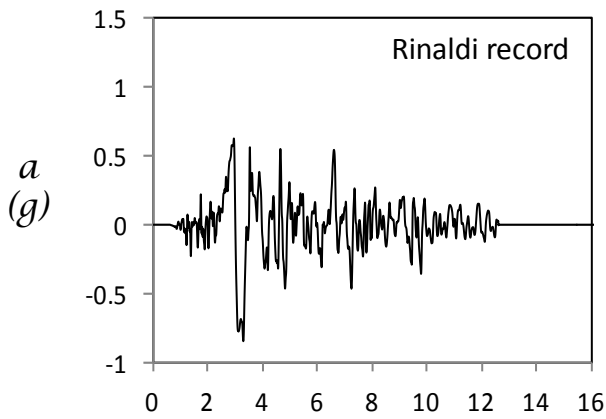

Figure B155. Acceleration time histories measured on the retrofitted building ($b = 3\text{m}$, $t = 0.05\text{m}$) with fixed tie beams while submitted to the record of Rinaldi.

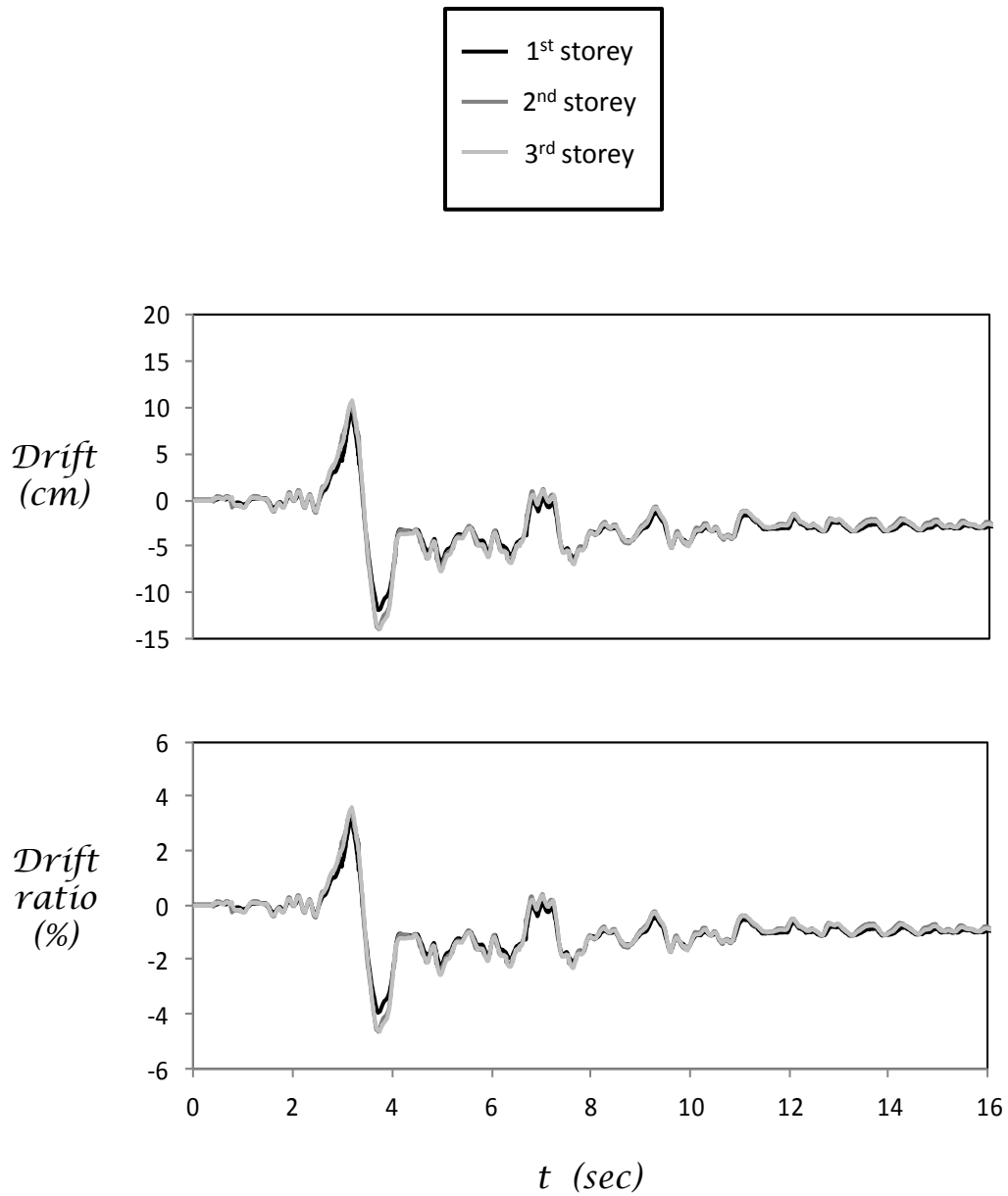

Figure B156. Time histories of storey drift and drift ratio of retrofitted building ($b = 3\text{m}$, $t = 0.05\text{m}$) with fixed tie beams while submitted to the record of Rinaldi.

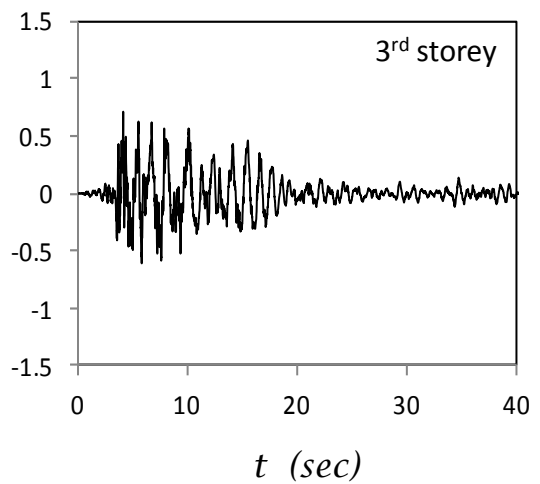
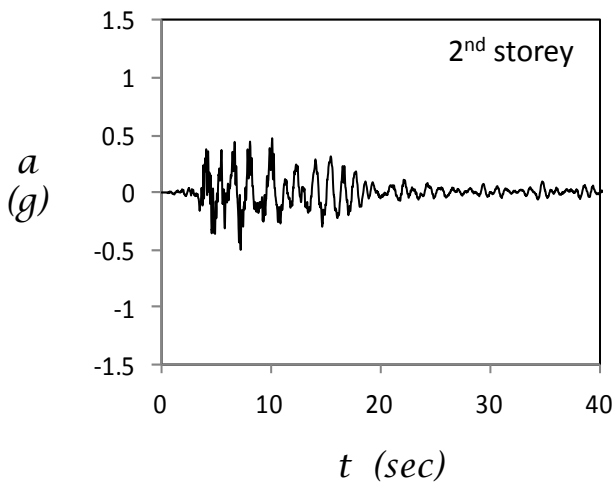
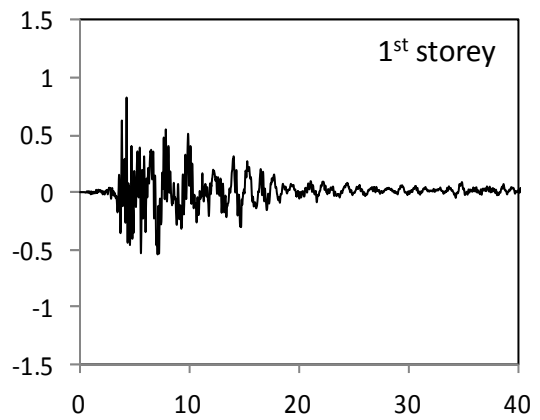
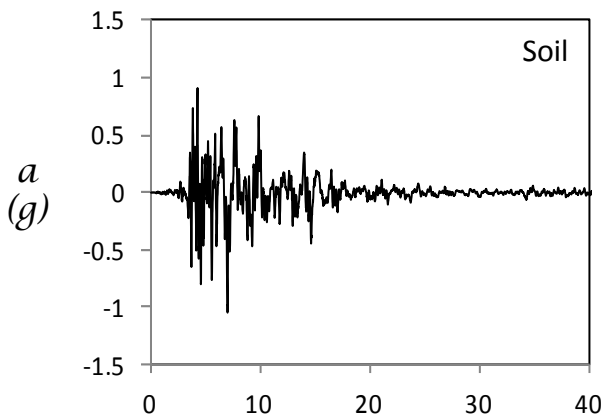
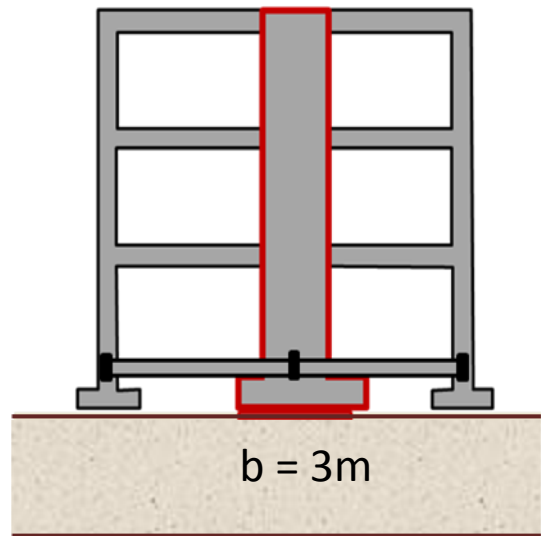
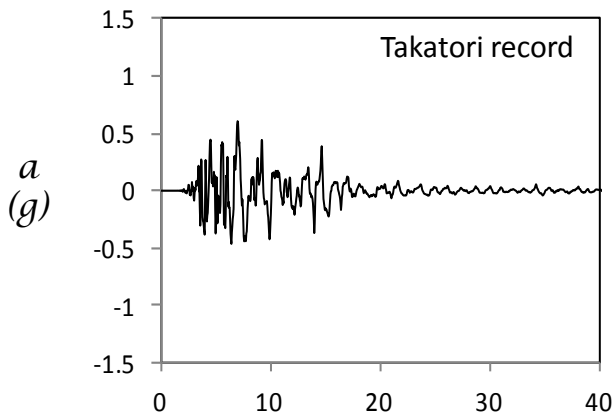

Figure B157. Acceleration time histories measured on the retrofitted building ($b = 3\text{m}$, $t = 0.05\text{m}$) with fixed tie beams while submitted to the record of Takatori.

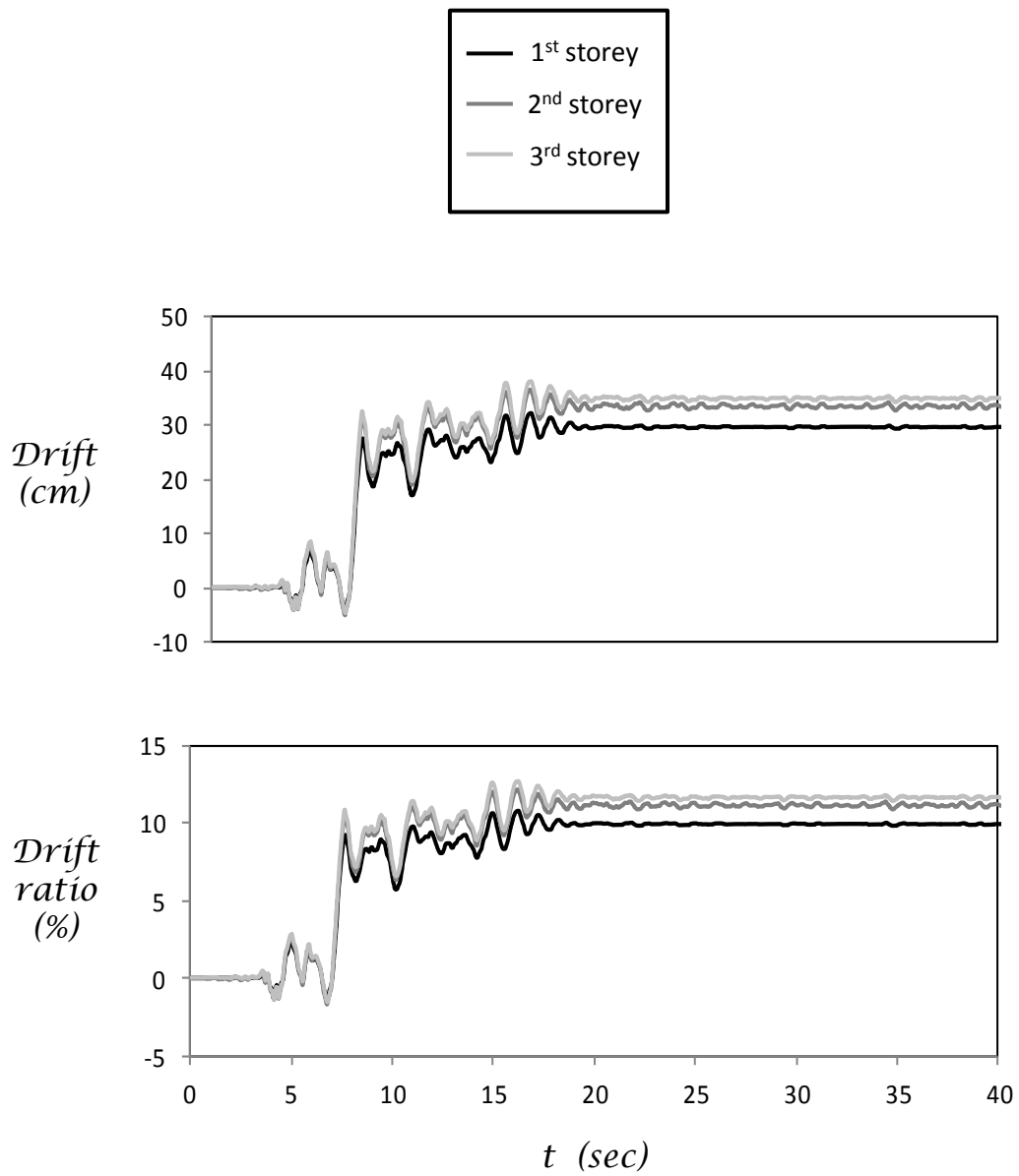

Figure B158. Time histories of storey drift and drift ratio of retrofitted building ($b = 3\text{m}$, $t = 0.05\text{m}$) with fixed tie beams while submitted to the record of Takatori.